



PM-349 3½-DIGIT DIGITAL PANEL METER

Introduction

The PM-349 Digital Panel Meter is a three and one-half-digit, fixed-range instrument with automatic polarity. The meter is available in any one of five ranges: +/-199.9 millivolts F.S., +/-1.999 volts F.S., +/-19.99 volts F.S., +/-199.9 volts F.S. or 1000 volts F.S.

Except for the +/-199.9 millivolt range, modification from one range to another may be easily accomplished by the substitution, addition, or deletion of one or two resistors. Calibration is readily accomplished by the adjustment of one potentiometer, accessible at the rear of the instrument. For operation, an external +/-5 vdc +/-5% power supply is required. See figure 1 for a typical power supply circuit.

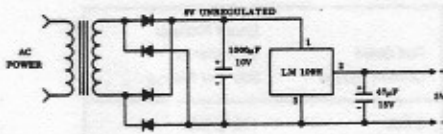

Figure 1. Typical Power Supply Schematic

Specifications

Range:

- 0 to +/-199.9 mV
- or 0 to +/-1.999 VDC
- or 0 to +/-19.99 VDC
- or 0 to +/-199.99 VDC
- or 0 to +/-1000 VDC

Accuracy:

+/- (0.05% Rdg. + 0.05% F.S.)

Update Rate:

3 readings/second nominal

Display:

0.3" high LED

Operating Temp:

0°C to +50°C

Power:

+5 VDC +/-5% @ 200 mA, max.

Size:

15/16" H x 2-1/2" W x 3-1/2" D
(23.8 mm H x 63.5 mm W x 82.6 mm D)

Weight:

4 oz (113 grams)

T/C:

+/- 0.02% Rdg/°C on 200 mV & 2V ranges;
+/- 0.025% Rdg/°C on other ranges.

Input Z:

200 mV range, 100 MOhms; 2V range, 1000 MOhms; 20V range, 1 MOhm; 200V & 1000V ranges, 10 MOhms

INSTRUCTIONS

Common-Mode Rejection:
80 db minimum

Common-Mode Compliance:
+/-1V between SIG LO & neg. terminal of 5V supply.

Decimal Location:
May be positioned by jumper on connector to any one of three locations: +/-X.XXX

Input Current (two lower ranges):
250 pA maximum (room temp.)

Input Voltage Protection:
+/-50 vdc or 50 vrms maximum, 200 mV or 2V ranges; +/-150 vdc or 150 vrms maximum, 20V range; +/-1000 vdc or 700 vrms maximum, 200V & 1000V ranges.

Overload Indication:
Positive overload: +1, negative overload: -1 is displayed for inputs exceeding full scale.

Operating Principles (See figure 2)

Analogue-to-digital conversion is accomplished in a single monolithic integrated circuit. The output of the A/D converter drives an LED display. Separate enable inputs provide means for independently blanking the polarity sign and the numerals. Decimal point selection is accomplished by external jumpers.

Light-emitting diodes (LED), arranged to form seven-segment numerals, provide the digital display. Electrical energy is converted to light within the LED, eliminating the need for light bulbs. In addition, to the digital display, LED's are grouped to display plus and minus signs to indicate polarity, an over-range "1" to indicate overload, and the three decimal points.

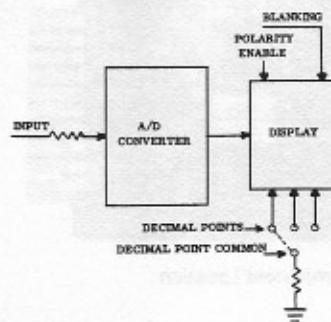

Figure 2. Simplified Block Diagram



Installation

1. Mount the PM-349 as follows:

- a. Cut hole in panel (figures 3 and 4).
- b. Slide trim plate over PM-349 housing, facing beveled edge of trim plate forward.
- c. Insert PM-349 through the cut-out in panel from front of panel.
- d. Fit mounting clips (2) into slots at sides of instrument. Foot of clip should face forward.
- e. Thread screws (2) into clips & tighten screws against rear surface of panel.

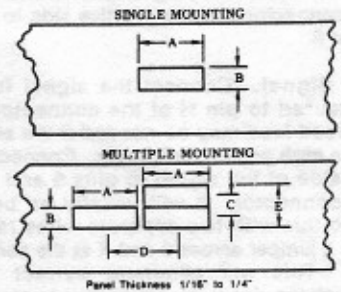

DIMENSIONS (inches)			
	Panel Cutout With Trim Plate	Center Line With Trim Plate	Center Line Without Trim Plate
A	2-17/32		
B	31/32		
C		15/16	1-3/16 (Min)
D		3-1/8 (Min)	3-1/8 (Min)
E			No. of Units x 15/16

Figure 3. Mounting Data

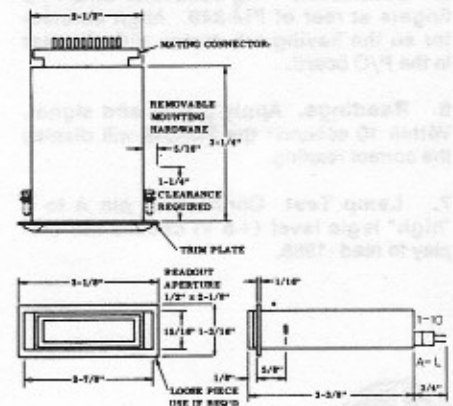

Figure 4. Outline Drawing

Installation Cont'd

2. Install a keying tab in connector to mate with PM-349 between contacts 1 and 2. The connector should be NLS part number 39-195, or equivalent. (See table I for connector pin information.)

**Table I
Connector Pin Information**

Pin No. (Top of Bd.)		Pin Letter (Bottom of Bd.)	
1	Decimal Pt. Com.	A	Lamp Test
2	N/C	B	10 ⁰ Decimal
3	N/C	C	10 ¹ Decimal
4	N/C	D	10 ² Decimal
5	Signal Low	E	N/C
6	N/C	F	N/C
7	N/C	H	Signal High
8	7-Segment and overload enable	J	N/C
9	+5V	K	Power Gnd
10	Polarity Enable	L	Power Gnd

Operation

1. **Power Supply.** Connect the negative side of the 5V supply to pin K and L of the connector and the positive side to pins 8 and 9.
2. **Signal.** Connect the signal to be measured to pin H of the connector. A shielded lead may be needed if the signal has a high source resistance. Connect the low side of the signal to pins 5 and K of the connector. It will usually be better to do this with two separate wires rather than a jumper across 5 and K at the connector. This will eliminate current flow through the signal low connection to pin 5.
3. **Polarity Display.** Jumper between pins 9 and 10 of the connector to display the polarity of the input signal. If polarity is not desired, do not install the jumper.
4. **Decimal Indicator** Jumper between pin 1 and pins B, C, or D depending upon which decimal point is to be illuminated. See below. If a decimal point is not desired, do not install the jumper.

Decimal Location +1 . 0 . 0 . 0
Connector Pin D C B

5. **Connector.** Plug connector onto P/C fingers at rear of PM-349. Align connector so the keying tab mates with the slot in the P/C board.
6. **Readings.** Apply power and signal. Within 10 seconds the PM-349 will display the correct reading.
7. **Lamp Test** Connecting pin A to a "high" logic level (+5 V) causes the display to read -1888.

Calibration.

1. Ensure a 5-minute warm-up period.
2. Verify the +5-volt power supply voltage. If necessary, adjust to +5V +/-0.1.
3. **200 Millivolt Meter.** With a precision DC power supply, apply +190.0 mVDC. Adjust potentiometer R4 at rear of meter until readout displays +1900.

NOTE: As in paragraph 3 above, for a 2-volt meter, apply +1.900 VDC; a 20-volt meter, apply +19.00 VDC; a 200-volt meter, apply +190.0 VDC; and a 1000-volt meter, apply 900 VDC.

Range Modification (Except 200 mV unit.)

1. Insert a small screwdriver or pen knife between case and rear cover, midway on case above printed circuit connector, and pry gently outward. Remove rear cover.
2. Slide panel meter assembly from case. Observe that red filter is now a loose piece and will be required for reassembly.
3. Observe resistor values that are in unit and compare to figure 5 and table II below. Install values of resistors as specified in table II to attain desired range.
4. If a decimal indicator is desired, refer to paragraph 4 under Operation.
5. Clean all solder joints and adjacent areas on printed circuit board to minimize leakage paths.
6. Reassemble unit by reversing steps 1 and 2.
7. A range modification resistor set covering the four higher ranges of the PM-349 is available from your distributor, specify NLS part number 39-356.

**Table II. Resistor Values in Range
Modification Kit**

RANGE	R9	R10
2V	100 k Ohms +/-5%	OMIT
20V	909 k Ohms +/-1%	100 k Ohms +/-1%
200V	10 M Ohms +/-1%	100 k Ohms +/-1%
1000V	10 M Ohms +/-1%	10 k Ohms +/-1%

Current Measurement

The PM-349 in the 200 mV or the 2 V range may be used to measure current. Because of the lower voltage drop, the 200 mV range is preferred.

To measure current, install a shunt resistor in the R10 location or externally between SIG HI and SIG LO. Install a jumper in the R9 location.

Select the value of the shunt resistor from table III below. One-percent metal-film or wire-wound resistors are recommended.

Table III Shunt Resistor Values

Full Scale Current Range	Shunt Resistor for meter in 200 mV Range
2 mA	100 OHMS
20 mA	10 OHMS
200 mA	1 OHMS
2 A	.1 OHM *

Full Scale Current Range	Shunt Resistor for meter in 2 V Range
2 mA	1000 OHMS
20 mA	100 OHMS
200 mA	10 OHMS
2 A	1 OHM *

* Use external shunt only.

Maintenance

Most of the PM-349 circuits are contained within the ICL 7107RCPL integrated circuit. A socket is provided to permit replacement without soldering.

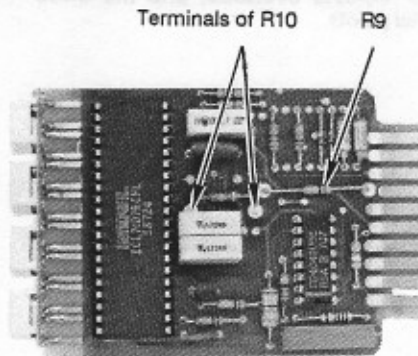

Figure 5. Component Location

Specifications Subject to Change without Notice



Non-Linear Systems
Originator of the digital voltmeter.
SAN DIEGO, CALIFORNIA

PHONE: (858) 535-2161
FAX: (858) 535-2169
www.nonlinearsystems.com