

INF

INFINITY[®] Temperature Thermocouple, RTD ohms

Operator's Manual



NEWPORT Electronics, Inc.



Additional products from

NEWPORT Electronics, Inc.

Counters	Rate Meters
Frequency Meters	Timers
PID Controllers	Totalizers
Clock/Timers	Strain Gauge
Printers	Meters
Process Meters	Voltmeters
On/Off	Multimeters
Controllers	Soldering Iron
Recorders	Testers
Relative	pH pens
Humidity	pH Controllers
Transmitters	pH Electrodes
Thermocouples	RTDs
Thermistors	Thermowells
Wire	Flow Sensors

For Immediate Assistance

In the U.S.A. and Canada: 1-800-NEWPORT[®]

In Mexico: (95) 800-NEWPORTSM

Or call your local NEWPORT Office.

NEWPORTnetSM On-Line Service
<http://www.newportUS.com>

Internet e-mail
info@newportUS.com

It is the policy of NEWPORT to comply with all worldwide safety and EMC/EMI regulations that apply. NEWPORT is constantly pursuing certification of its products to the European New Approach Directives. NEWPORT will add the CE mark to every appropriate device upon certification.

The information contained in this document is believed to be correct but NEWPORT Electronics, Inc. accepts no liability for any errors it contains, and reserves the right to alter specifications without notice.

WARNING: These products are not designed for use in, and should not be used for, patient connected applications.

PATENT NOTICE: The "Meter Case Bezel Design" is a trademark of NEWPORT Electronics, Inc., registered in the U.S.

PATENT NOTICE: This product is covered by one or more of the following patents: U.S. Pat. No. Des. 336,895; 5,274,577 / Canada 2052599; 2052600 / Italy 1249456; 1250938 / France Brevet No. 91 12756 / Spain 2039150; 2048066 / UK Patent No. GB2 249 837; GB2 248 954 / Germany DE 41 34398 C2. Other International Patents Pending.



This device is marked with the international hazard symbol. It is important to read the Setup Guide before installing or commissioning this device as it contains important information relating to safety and EMC.



Table of Contents - Digital Panel Meter

SECTION 1	INTRODUCTION	Page
1.1	Description	1-1
1.2	Features	1-1
1.3	Available models.....	1-2
SECTION 2	UNPACKING	2-1
SECTION 3	SAFETY CONSIDERATIONS	
3.1	Power wiring	3-1
3.2	Humidity	3-1
3.3	Fumes and gases	3-1
SECTION 4	PARTS OF THE METER	
4.1	Front of the meter	4-1
4.2	Rear of the meter	4-4
SECTION 5	SETUP	
5.1	Conditions requiring disassembly	5-1
5.2	Disassembly	5-1
5.2.1	Rating/Product ID label	5-4
5.2.2	Main board power jumpers.....	5-5
5.2.3	Printed circuit board(s) installation	5-5
5.2.4	How to access jumpers.	5-7
5.2.5	Panel mounting.....	5-10
5.2.6	Bench top use	5-12
5.3	AC wiring	5-12
5.4	Cold-junction compensation board installation for thermocouples	5-13
5.4.1	Cold-junction compensation board wiring	5-14
5.4.2	Thermocouple wire colors.....	5-14
SECTION 6	TYPE K THERMOCOUPLE SETUP EXAMPLE	
6.1	Introduction	6-1
6.2	Jumper information	6-1
6.3	Cold-junction compensation board installation	6-3
6.4	AC wiring	6-4
6.5	Cold-junction compensation board wiring	6-5
6.6	Re-configuring the meter for other characteristics	6-6
6.6.1	To select thermocouple type	6-6
6.6.2	To select the units of measurement	6-7
6.6.3	To select whether temperature units are displayed	6-7



Table of Contents

	Page
6.6.4	To select display resolution 6-8
6.7	Cold-junction compensation offset procedure 6-8
6.7.1	Set thermocouple zero..... 6-9
6.7.2	Special cold junction calibration 6-10
 SECTION 7 3-WIRE 100 OHM PLATINUM (DIN) RTD/OHMS SETUP EXAMPLE	
7.1	3-wire 100 ohm platinum RTD information 7-1
7.2	Jumper information 7-1
7.3	Input connections. 7-3
7.4	AC wiring 7-4
7.5	Re-configuring the meter for other characteristics 7-6
7.5.1	To select RTD type. 7-6
7.5.2	Select the units of measurement 7-7
7.5.3	To select temperature units 7-7
7.5.4	To select the display resolution 7-8
7.6	2-wire and 4-wire RTD wiring 7-9
7.7	10 Ω , 4-wire copper RTD information 7-11
7.7.1	Jumper information for 10 Ω copper RTD 7-12
7.7.2	Input connections 7-13
7.7.3	AC wiring 7-14
7.7.4	Programming the meter for the calibration run 7-15
7.7.5	Taking the input calibration data 7-18
7.7.6	Entering the calibration data in input scale and offset (example) 7-19
7.7.7	10 Ω copper RTD calibration with the highest accuracy 7-20
7.7.8	Verifying the numbers 7-21
7.7.9	Technical discussion 7-22
7.7.9.1	Use of linear scale for copper 7-22
7.7.9.2	Use of slower read rate 7-22
7.7.9.3	RTD ohms and meter current 7-22
7.7.9.4	2-wire hookup 7-23
7.7.9.5	3-wire hookup 7-23
 SECTION 8 TRANSMITTER HOOKUP EXAMPLE WITH RTD	
8.1	Jumper information 8-1
8.2	Transmitter input connections 8-2
8.3	Wiring with transmitter 8-3
8.3.1	For RTDs 8-3
8.3.2	For Thermocouples 8-4
8.4	TC/RTD transmitter calibration 8-5



	Page
8.5	Recording the calibration values for RTD 8-8
8.5.1	Setting the lower of the two inputs 8-8
8.5.2	Setting the upper of the two inputs 8-9
SECTION 9	DETAILED EXPLANATION OF LOCKOUT CONFIGURATIONS AND METER FUNCTION MENUS
9.1	Individual lockout information 9-1
9.2	Meter function menus 9-8
9.2.1	Input 9-8
9.2.2	RDG.CNF (Reading Configuration) 9-9
9.2.3	RDG SC (Reading Scale) and RDG OF (Reading Offset) ... 9-11
9.2.4	IN CNF (Input Configuration) 9-13
9.2.5	IN.SC.OF (Input Scale and Offset) 9-15
9.2.6	DEC PT (Decimal Point) 9-17
9.2.7	CNT BY (Count By) 9-18
9.2.8	FIL.CNF (Filter Configuration) 9-19
9.2.9	FIL TI (Filter Time Constant) 9-20
9.2.10	SP CNF (Setpoints 1 & 2 Configuration) 9-21
9.2.11	AL CNF (Alarm Configuration) 9-23
9.2.12	AL FNC (Alarm Function) 9-25
9.2.13	AL RDG (Alarm Readings) 9-26
9.2.14	SP DB (Setpoint Deadband) 9-27
9.2.15	AL DB (Alarm Deadband) 9-27
9.2.16	OUT.CNF (Output Configuration) 9-28
9.2.17	OT.SC.OF (Output Scale and Offset) 9-30
9.2.18	BAUD (Baud Rate) 9-31
9.2.19	SERCNF (Serial Communication Configuration) 9-32
9.2.20	ADDRES (Multipoint Communications Device Address) ... 9-33
9.2.21	DAT FT (Data Format) 9-33
9.2.22	BUS FT (Bus Format) 9-35
9.2.23	SERCNT (Serial Count) 9-37
9.2.24	Analog Output Calibration Numbers 9-38
SECTION 10	SETPOINTS/ALARMS
10.1	Features overview 10-1
10.2	Unlocking the features 10-3
10.3	Selecting "SP CNF" setpoint configuration features 10-3
10.4	Deviation functions for alarms 10-4
10.5	Selecting "AL CNF" alarm configuration features 10-6
10.6	Selecting "AL FNC" alarm function features 10-8
10.7	"AL RDG": Select delay in alarm Action 10-9



Table of Contents

	Page
10.8	“SP DB”: Select SP 1 and SP 2 deadband 10-9
10.9	“AL DB”: Select SP 3 and SP 4 deadband 10-10
10.10	“OUT.CNF”: Control flashing of the display 10-10
10.11	Entering setpoint levels (in run mode) 10-10
SECTION 11	PEAK AND VALLEY READINGS 11-1
SECTION 12	ANALOG OUTPUT OPTION
12.1	Features overview 12-1
12.2	Unlocking 12-2
12.3	“OUT.CNF”: Configuring the output 12-2
12.4	“OT.SC.OF”: Setting output scale and offset 12-3
12.5	Board installation; Entering the trim data 12-4
12.6	Filter configuration “FIL.CNF” value to be transmitted on analog output 12-5
SECTION 13	BCD OPTION
13.1	Features overview 13-1
13.2	BCD card jumper table 13-3
13.3	Interconnect board 13-4
13.4	50-Line cable compatibility 13-4
13.5	Selecting the source of BCD data: “OUT.CNF” 13-4
13.6	Hold control 13-5
13.7	Data Ready timing pulses 13-5
13.8	Bringing out the BCD overflow line 13-5
13.9	3 Digit at a time multiplex 13-5
13.10	6 Digit at a time card address 13-6
13.11	Select data polarity: Jumper S8 13-7
13.12	Decimal point address code 13-7
13.13	Applying non-isolated/isolated power 13-7
13.14	Driving a printer 13-7
SECTION 14	RELAY OPTION
14.1	Features overview 14-1
14.2	Relay board jumper table 14-2
SECTION 15	RS-232 OR RS-485 OPTION BOARD
15.1	Features overview 15-1
15.2	Front panel pushbutton configuration 15-2
15.3	Instructions for using the setup program 15-3
15.4	Screen error messages 15-7
15.5	Serial communications sample program 15-8
15.5.1	Program objectives 15-8
15.5.2	Code and [Notes] 15-9

SECTION 16 EXTERNAL CONTROL LINES

16.1	Tare (Pin 1)	16-1
16.2	Peak (Pin 2)	16-2
16.3	Valley (Pin 3)	16-2
16.4	SWLIN2 (Pin 4)	16-2
16.5	Peak & Valley or External Reset (Pin 5)	16-2
16.6	Push to Cal (Pin 6)	16-2
16.7	Digital Ground (Pin 7)	16-2
16.8	+5 V (Pin 8)	16-3
16.9	Display Hold (Pin 9)	16-3
16.10	Lockout EEPROM and 'MENU' button (Pin 10)	16-3
16.11	Print Command and/or Reset of Alarms (Pin 11)	16-3
16.12	Nonstandard RX (Pin 12) and Non-standard TX (Pin 13)	16-3
16.13	Push to Cal (Pin 14)	16-3
16.14	+V Ext (Pin 15)	16-4
16.15	SP1 (Pin 16)	16-4
16.16	SP2 (Pin 17)	16-4
16.17	AL1 (Pin 18)	16-4
16.18	AL2 (Pin 19)	16-4
16.19	GND Ext (Pin 20)	16-4

SECTION 17 TROUBLESHOOTING- DISPLAY MESSAGES AND TROUBLESHOOTING GUIDE

17.1	Error mode messages	17-1
17.1.1	Flashing "999999" (numerical overflow)	17-1
17.1.2	Flashing "ERR 01" (offset overflow)	17-1
17.1.3	Flashing "ERR 02" (setpoint overflow)	17-1
17.1.4	"NOSTOR" & "STORED" (programming entries in EEPROM)	17-2
17.1.5	Flashing "+OVLD" (positive input overload)	17-2
17.1.6	Flashing "+OPEN" (open sensor indication)	17-2
17.1.7	Flashing "-OPEN" (open sensor indication)	17-2
17.1.8	Flashing "I OVSC" (input overscale)	17-2
17.1.9	Flashing "R OVSC" (reading overscale)	17-2
17.1.10	Flashing "CB OVF" (count by overflow)	17-2
17.1.11	Flashing "UOM.OVF" (unit of measure overflow)	17-3
17.2	Troubleshooting guide	17-3

SECTION 18 SPECIFICATIONS

18.1	Thermocouple input	18-1
18.2	RTD input	18-1
18.3	General	18-2

SECTION 19 FACTORY PRESET VALUES 19-1



Table of Contents

	Page
SECTION 20 RECORD YOUR SETUP DATA VALUES	20-1
SECTION 21 CELSIUS TABLES	
APPENDIX A Type J Thermocouple	21-1
APPENDIX B Type K Thermocouple	21-2
APPENDIX C Type T Thermocouple	21-4
APPENDIX D Type E Thermocouple	21-5
APPENDIX E Type N Thermocouple	21-6
APPENDIX F Type R Thermocouple	21-8
APPENDIX G Type S Thermocouple	21-10
APPENDIX H Type B Thermocouple	21-12
APPENDIX I Type J DIN Thermocouple	21-14
APPENDIX J Type RTD 100 Ω (Alpha = 0.00385)	21-15
APPENDIX K Type RTD 100 Ω (Alpha = 0.00392)	21-16
SECTION 22 TEMPERATURE CONVERSION CHART	22-1

1. Introduction

This manual is applicable to all meters with serial number 1520525 and larger.

1.1 DESCRIPTION

The Newport INFINITY temperature meter series is a complete line of process indicators/controllers, offering exceptional performance.

The "INFT" INFINITY temperature meter is front panel programmable to accept any of 9 thermocouple calibrations, (J, K, T, E, N, R, S, B, and DIN J) or 100 ohm Pt (385 or 392 curve) or 10 ohm Copper RTDs with either 2-, 3-, or 4-wire configuration. The INFT meter will accept inputs from 0.6 to 6000 ohms. All temperature inputs may be displayed in °F, °C or Kelvin.

The INFINITY temperature meter can also be used as a precise 2-, 3-, or 4-wire ohmmeter for resistance in the range 0.6 to 6000 ohms; this linear usage is also described in this manual.

A unique linearization method allows the microprocessor in the INFT to utilize the entire NIST calibration tables.

Configuring the INFT is accomplished through the 5 front panel buttons. If the optional RS-232 or RS-485 communications are installed, the user may remotely set the display parameters.

Options for the INFT include analog and BCD outputs, relay outputs, and RS-232 or RS-485 communications.

1.2 FEATURES

The following is a list of features of the INFT.

- 1.0°, 0.1°, 0.01° resolution
- 9 Thermocouple calibrations: J, K, T, E, N, R, S, B, DIN J
- 2-, 3-, or 4-wire 100 ohm Platinum or 10 ohm Copper RTDs
- Peak & Valley detection and memory
- Up to 12 readings per second
- 4 isolated open-collector outputs(standard) and optional isolated relay or isolated BCD and isolated analog outputs
- Optional isolated RS-232 or RS-485 communications
- NEMA-4 Front Panel/IP65
- Non-volatile memory without battery back-up
- 115 V ac, 50/60 Hz, 230 V ac, 50/60 Hz power supply

1.3 AVAILABLE MODELS

The following INFT models are available from NEWPORT ELECTRONICS, INC. or one of their AUTHORIZED STOCKING DISTRIBUTORS:

MAIN ASSEMBLIES

MODEL NUMBER	DESCRIPTION
INFT0	Red LEDs, 115V ac, 50/60Hz
INFT1	Green LEDs, 230 V ac, 50/60Hz
INFT2	Red LED's, 115V ac, 50/60 Hz
INFT3	Green LED's, 230 V ac, 50/60Hz

NOTE: The following options are available installed at the time of purchase or as separate items installed by the user after purchase.

Analog Output Board, BCD Output Board, Relay Output Board, RS-232 Communications Board, and RS-485 Communications Board.

CONTROL/BCD OUTPUT OPTIONS

MODEL NUMBER	DESCRIPTION
"0"	Standard four open-collector outputs are standard and included with the "1" and "2" options
"1" (BCD1)	Isolated BCD Output Board
"2" (REL1)	Dual 7A Form-C Relays

NOTES: Choose only one Control/BCD output option per meter. A 40-pin mating connector is included with the BCD option.

ANALOG OUTPUT

MODEL NUMBER	DESCRIPTION
"0"	None
"1" (ANO2)	Isolated configurable analog (4-20mA, 0-1, 0-5, 1-5 0-10V dc 0-20 mA) output

SERIAL COMMUNICATIONS OPTION

MODEL NUMBER	DESCRIPTION
"1" (RS20)*	Isolated RS-232 Communications
"2" (RS40)**	Isolated RS-485 Communications

NOTES: Choose only one option per meter. Both computer communications come with 3.5" and 5.25" set/programming disks (1 each) and one 6 ft. communications cable with phone plug termination.

* Recommend purchase of 9SC2 or 25SC2
(see OPTIONS below)

** Recommend purchase of 9SC4 or 25SC4
(see OPTIONS below)

OPTIONS

MODEL NUMBER	DESCRIPTION
FS	Custom Calibration/configuration
BL	Blank lens
OH	Optional housing
FP3	Front panel for "OH" housing without pushbuttons
9SC2	9-pin Serial Connector for RS-232
9SC4	9-pin Serial Connector for RS-485
25SC2	25-pin Serial Connector for RS-232
25SC4	25-pin Serial Connector for RS-485
RP18	19" Rack panel for one (1) meter
RP28	19" Rack panel for two (2) meters
RP38	19" Rack panel for three (3) meters

This page is intentionally left blank

2. Unpacking

Remove the Packing List and verify that all equipment has been received. If there are any questions about the shipment, please call the NEWPORT Customer Service Department at 1-800-NEWPORT (800) 639-7678 or (714) 540-4914.

Upon receipt of shipment, inspect the container and equipment for any signs of damage. Take particular note of any evidence of rough handling in transit. Immediately report any damage to the shipping agent.

NOTE: The carrier will not honor any claims unless all shipping material is saved for their examination. After examining and removing contents, save packing material and carton in the event reshipment is necessary.

When you order your INFINITY meter, you will receive the following items in the shipping box:

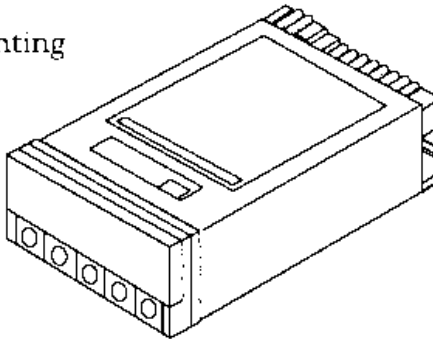
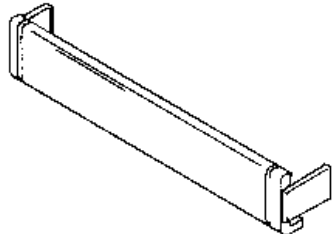
<u>QTY</u>	<u>DESCRIPTION</u>	<u>ILLUSTRATION</u>
1	Basic Meter in a Mounting Sleeve with Gasket	
1	Optional Front-Panel Button Cover available with return of the postcard included in meter box	

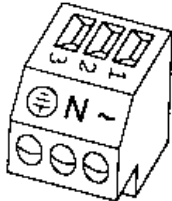
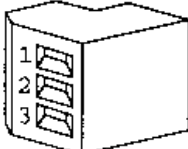
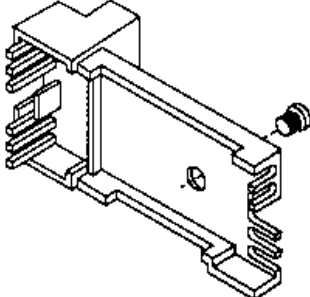
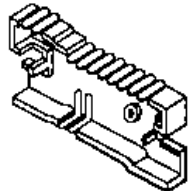
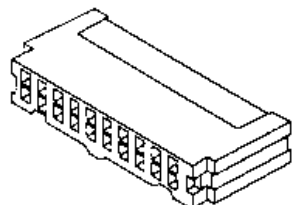
<u>QTY</u>	<u>DESCRIPTION</u>	<u>ILLUSTRATION</u>
1	AC Power Connector (orange - P1)	
2	Input Connectors (gray - P3 and P9)	
1	Thermocouple Rear Protective Cover with Screw	
	OR	
	RTD Rear Protective Cover with Screw	
1	20-Socket Ribbon Connector (P2 Connector)	

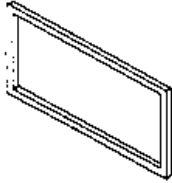
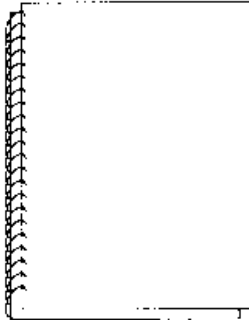
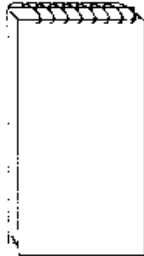
<u>QTY</u>	<u>DESCRIPTION</u>	<u>ILLUSTRATION</u>
2	Panel-Mounting Gaskets	
1	Temperature Owner's Guide	
1	Quick Reference Guide	

Other items may also be in the box depending on the options ordered. Refer to specific options described previously.

This page is intentionally left blank

3. Safety Considerations

The meter is protected in accordance with Class II of IEC 348 and VDE 0411.

*WARNING: If your meter is to be wired to sensors or control inputs which could have hazardous potentials, these potentials will be carried through to the 20-pin digital output connector at the rear, and will be present on the meter's circuit boards. Install the rear 20-pin mating connector and insert the electronics into the case **before** connecting the meter to any source of possible high voltage.*

DO NOT contact any exposed metal parts or interconnect any option board(s) or change any jumpers on this meter while it is connected to AC voltage.

To provide safe operation, follow these guidelines:

3.1 POWER WIRING

The meter has no power-on switch, so it will be in operation as soon as power is applied.

3.2 HUMIDITY

Do not expose your meter to rain or condensing moisture.

3.3 FUMES AND GASES

Do not operate your meter in flammable or explosive atmospheres.

This page is intentionally left blank

4. Parts of the Meter

4.1 FRONT OF THE METER

The following is a brief description of each part of the front of the meter.

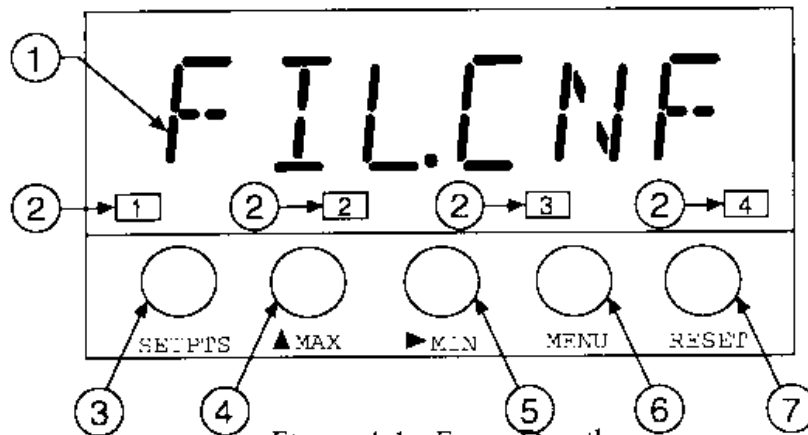

Figure 4-1. Front Detail

ITEM	DESCRIPTION
1	<p>-.8.8.8.8.8. or 8.8.8.8.8.8.</p> <p>6-digit, 14 segment, alphanumeric 0.54" high LED display with programmable decimal point.</p>
2	<p>SETPOINT LED</p> <p>These LEDs, labeled 1 through 4, display the status of setpoints 1, 2, 3 (Alarm 1), and 4 (Alarm 2).</p>
3	<p>SETPTS BUTTON</p> <p>This button functions only in the run mode. When the Setpoint/Alarm features are unlocked, pressing this button sequentially recalls the previous setpoint settings to the display. After the '▶/MIN' and '▲/MAX' buttons are used to alter those values as desired, pressing the 'SETPTS' button, again, stores these new values.</p> <p>Unless the 'SETPTS' button is pressed, each of the four setpoint values is displayed for approximately 10 seconds after the last press of the 'SETPTS' button. Holding the 'SETPTS' button depressed stalls this automatic sequence, retaining the most recent setpoint number on the display.</p>

ITEM	DESCRIPTION
4	<p>▲ /MAX BUTTON</p> <p>During run mode, pressing this button displays the "HI RDG" (peak reading) value that has occurred up to the moment the 'MAX' button is pressed. This peak reading flashes, to distinguish its value from the current readings. Since this is a dynamic peak reading, the value will change if the value increases while reviewing it.</p> <p>To return to display of the current readings without resetting the peak-value memory to zero (0), press the 'MAX' button once again.</p> <p>To reset the peak-value memory (start a new peak determining period), press the 'RESET' button once.</p> <p>During the configuration mode, the 'MAX' button is used to change the numerical value of the flashing digit displayed. For submenu items, such as "L1C.1=0", pressing the 'MAX' button toggles the choice from "0" to "1".</p> <p>The meter allows rapid changes of a displayed numerical value by making "0" the first value to occur when the 'MAX' button is pressed. After that, the numbers increase to "9" and then roll over to "0" again. A negative ("-") symbol may be displayed in the most significant digit (i.e. the digit at the far left such as shown here "-.8.8.8.8.8.")</p> <p>In the SETPT (SETPOINT) mode (SP1, SP2, etc), pressing the 'MAX' button causes the flashing digit to increment by 1 from 0 to 9.</p>
5	<p>▶ /MIN BUTTON</p> <p>During run mode, pressing the 'MIN' button recalls the "LO RDG" (valley reading) measured since the last press of the 'RESET' button. This lowest value flashes, to distinguish it from the current process display. Since this is a dynamic valley reading, the value will change if the value decreases while reviewing it.</p>

ITEM	DESCRIPTION
	<p>To return to the actual process display, without resetting the low-value memory, press the 'MIN' button once again.</p> <p>To reset the memory for current-value readings (start a new observation period), press the 'RESET' button once and the meter will return to the run mode.</p> <p>In the configuration mode, once in a submenu (like TC type) the 'MIN' button allows you scroll through the available choices such as "J", "K", etc.</p> <p>In the SETPT mode, the 'MIN' button advances the flashing digit to the right.</p>
6	<p>MENU BUTTON</p> <p>In the run mode, this button terminates the measurement process and allows you to enter the configuration mode, advancing through the configuration menus.</p> <p>In the configuration mode, this button will store changes in the non-volatile memory at the same time advancing the display to the next menu item.</p>
7	<p>RESET BUTTON</p> <p>In the run mode, pressing the 'RESET' button once erases the memories of peak ("HI RDG"), valley ("LO RDG"), and ALARM latches. The display then returns to the run mode.</p>
	<div style="border: 1px solid black; padding: 5px; margin-bottom: 10px;"> <p><i>WARNING: Pressing the 'RESET' button two (2) times will result in a hard reset of the meter. This will clear the Peak & Valley, Alarm latches and meter reading and immediately begin a new measurement.</i></p> </div> <p>In the configuration mode, pressing the 'RESET' button once, displays the previous selection. For example, if you were in "IN CNF" then pressed the 'RESET' button once, the display will then show "RD.SC.OF". Press the 'RESET' button two times to return to the run mode.</p>

4.2 REAR OF THE METER

The following is a brief description of each part of the rear of the meter. The label on the top of the mounting sleeve (not the case) identifies the location of the connectors found at the rear of the meter. Figure 4-2 shows this label.

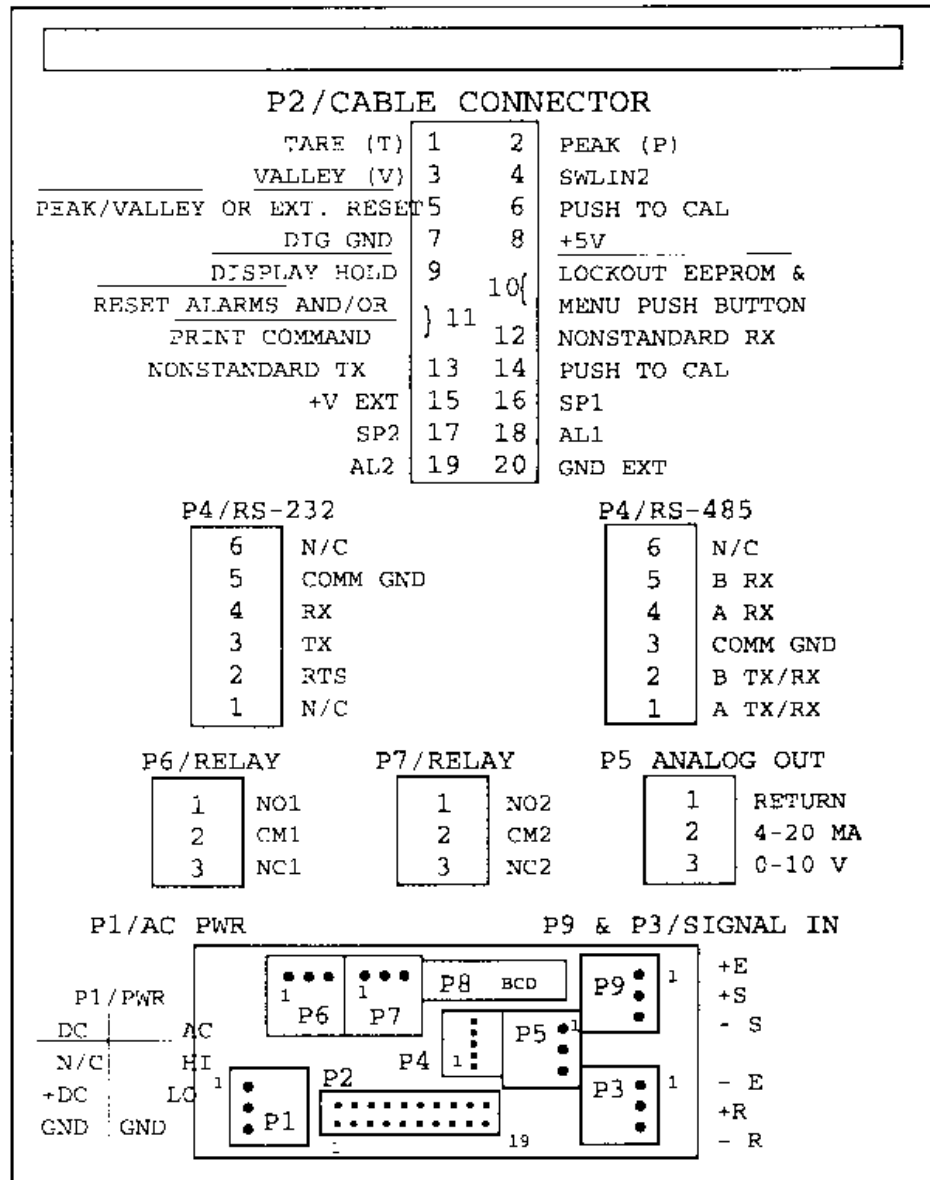

Figure 4-2. Connector Label for Rear Connectors

Figure 4-3 shows the rear of the meter with the optional relay output board installed.

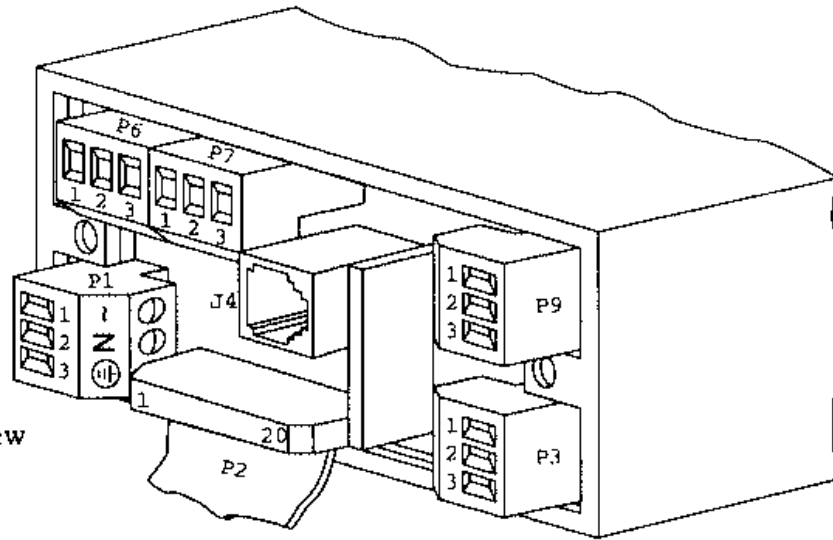

Figure 4-3. Rear View

Figure 4-4 shows the rear of the meter with the optional BCD output board installed.

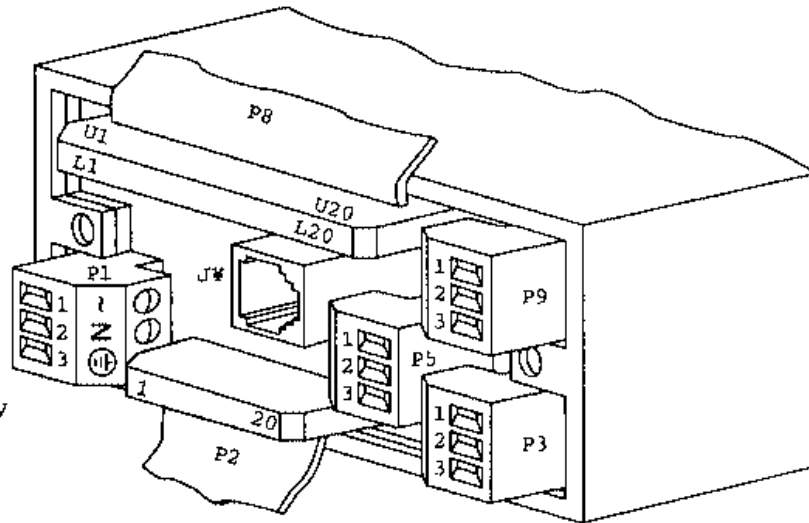

Figure 4-4. Rear View

TABLE 4-1 REAR CONNECTOR DESCRIPTIONS

CONNECTOR #	DESCRIPTION
P1	AC Power Connector
P2	External I/O Connector
P3	Input Connector, -E, +R, -R
J4	Optional RS-232 or RS-485 Phone Jack Connector
P5	Optional Analog Out Connector
P6	Optional Form-C Relay #1 Connector
P7	Optional Form-C Relay #2 Connector
P8	Optional BCD Connector
P9	Input Connector, +E, +S, -S

This page is intentionally left blank

5. Setup

5.1 CONDITIONS REQUIRING DISASSEMBLY

You may need to open the meter for several reasons:

1. To inspect the rating label on the case (not the same label as on the sleeve) (Section 5.2.1).
2. To check or change the 115 V ac or 230 V ac or main board jumpers (Sections 5.2.2 and 5.2.4).
3. To install optional output board(s) (Section 5.2.3).
4. To mount the meter in a panel (Section 5.2.5).

5.2 DISASSEMBLY

The following procedure describes how to open up the meter. Figure 5-1 shows the meter with the bezel and Figure 5-2 shows the meter with the optional housing.

1. Make sure the AC power is removed from the meter.
2. Remove the cover mounting screw and set aside.
3. Remove the rear protective cover and set aside.
4. Remove all wiring connectors from the rear of the meter.
5. Remove both thumbnuts and set aside.
6. Remove the sleeve and set aside.
7. Bend the side panel detents on the case (shown in Figure 5-3) outward to release the boards. Pull the board assembly out of the case by the mounting screw stem.

NOTE: From this point forward, these 7 steps are referred to as "Reveal the main board".

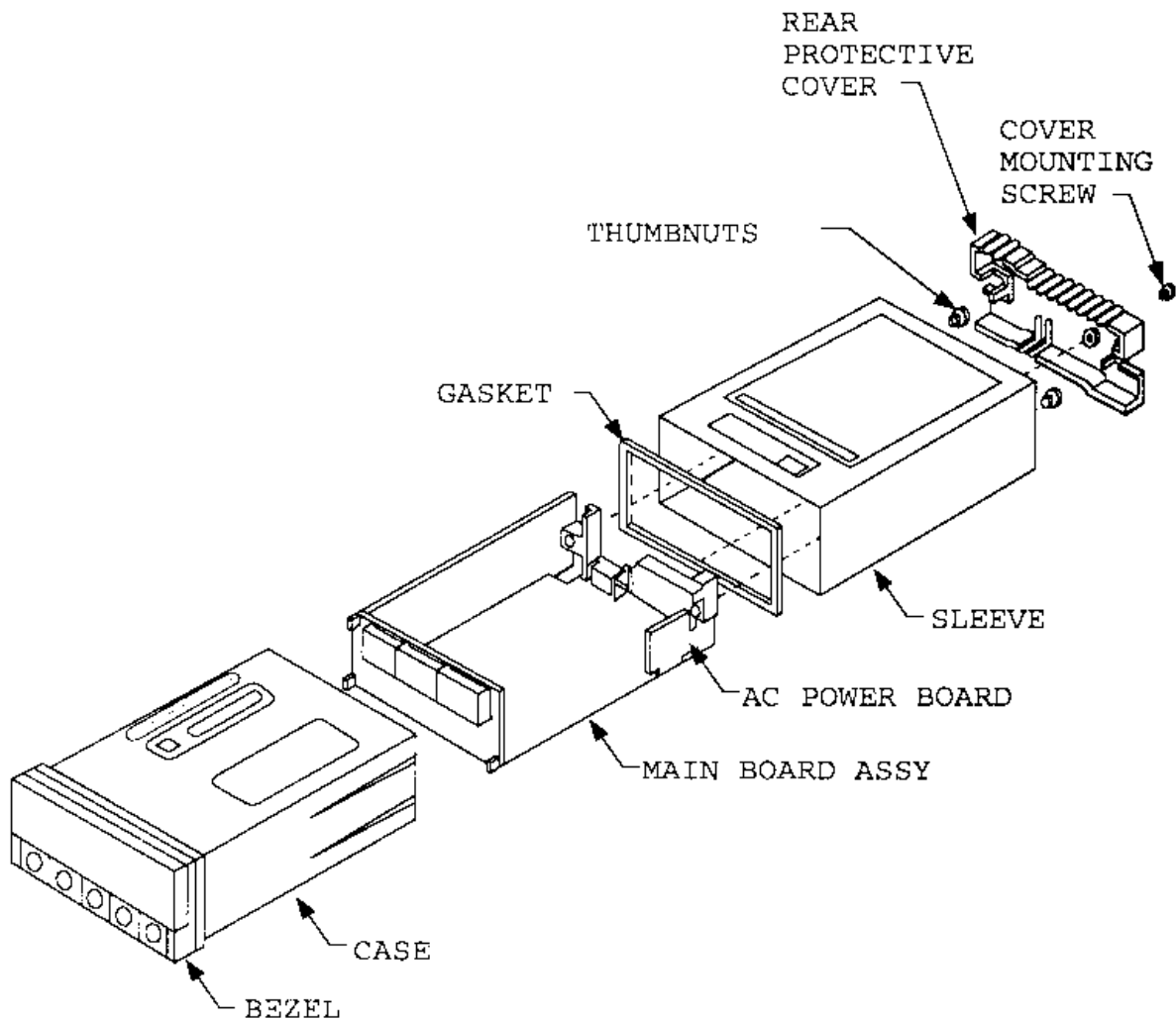

Figure 5-1. Meter Exploded View

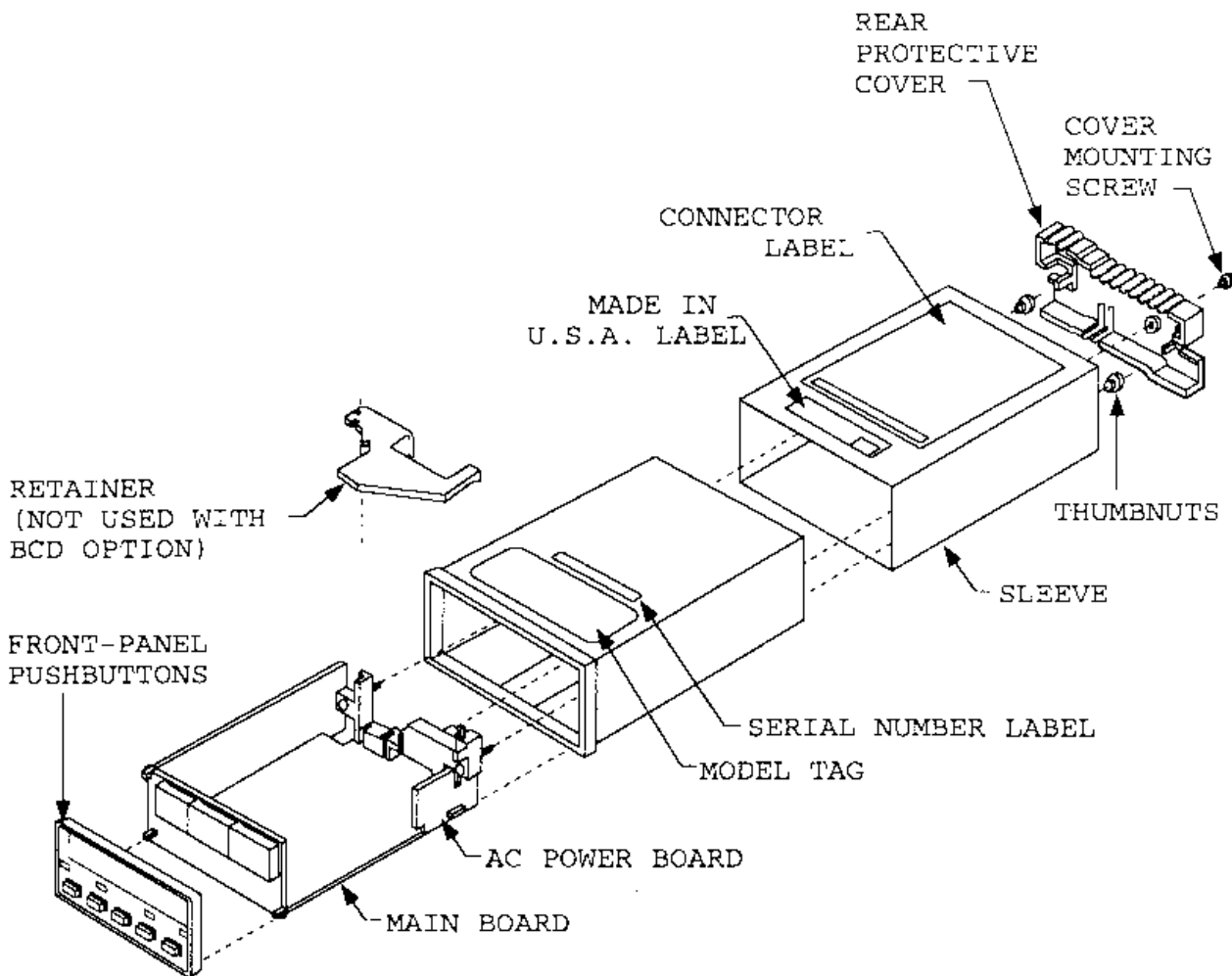

Figure 5-2. Meter Exploded View (with optional housing)

5.2.1 RATING/PRODUCT ID LABEL

To look at the Rating/Product ID label on the case, you must follow the first 6 steps as described in Section 5-2. Refer to Figure 5-3 for the location of the Product Identification Label.

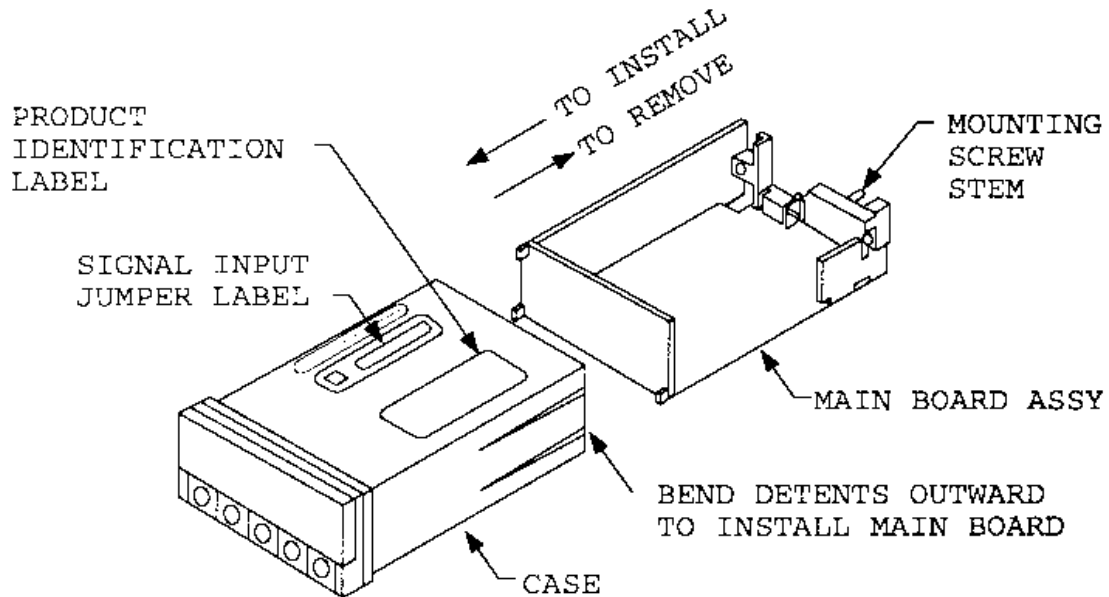

Figure 5-3. Board Assembly Removing/Installing Detail

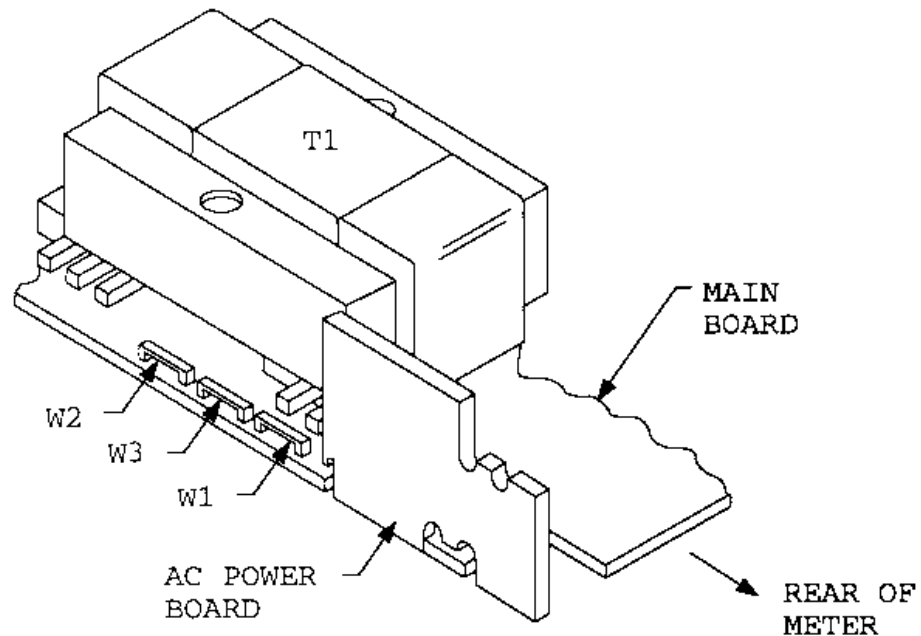

Figure 5-4. Transformer Jumpers

5.2.2 MAIN BOARD POWER JUMPERS

To check voltage jumpers or to change from 115 V ac to 230 V ac:

1. "Reveal the Main Board" (refer to Section 5.2, Disassembly).
2. Locate the main board assembly and position it in front of you the same way as shown in Figure 5-4.
3. On the main board, locate the transformer jumpers W1, W2, and W3 near the transformer T1.

If your power requirement is 115 V ac, jumpers W1 and W2 should be installed.

(DO NOT INSTALL W3)

If your power requirement is 230 V ac, jumper W3 should be installed.

(DO NOT INSTALL W1 OR W2)

5.2.3 PRINTED CIRCUIT BOARD(S) INSTALLATION

To install optional printed circuit board(s):

1. "Reveal the Main Board" (refer to Section 5.2, Disassembly).
2. Using Figure 5-5 as a reference, insert option board(s) into the corresponding slot(s) on the main board. Each circuit board is keyed to fit in its own position.
3. To re-assemble the meter, follow the steps in Section 5.2 in reverse order.

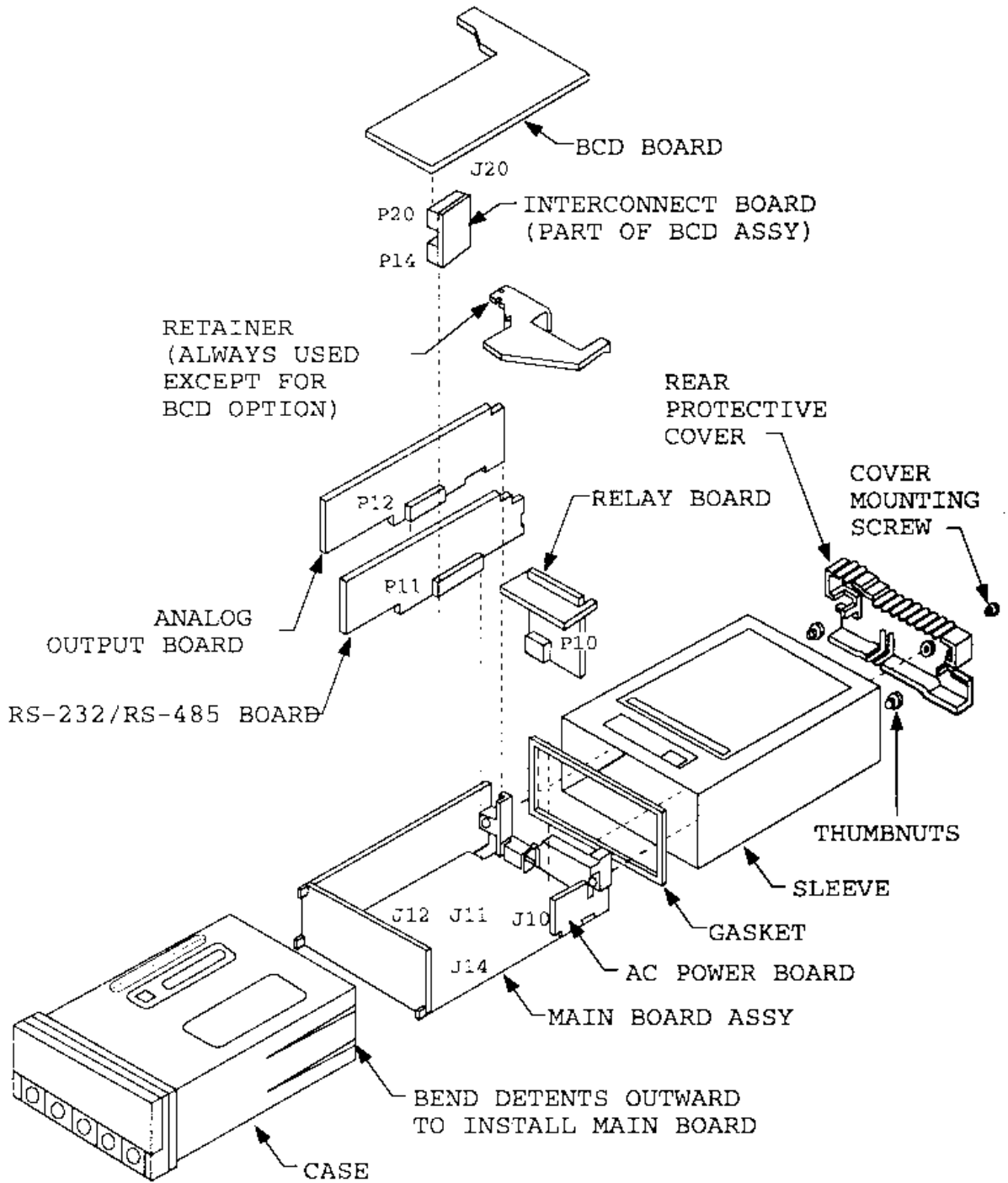

Figure 5-5. Optional Printed Circuit Board Locations

5.2.4 HOW TO ACCESS JUMPERS

To gain access to jumpers on the various printed circuit boards:

1. "Reveal the main board" (refer to Section 5.2, Disassembly).

NOTE: To access the S1 and S2 jumpers on the Signal Input Board, you only need to remove the mounting sleeve.

2. To re-assemble the meter, follow the steps in reverse order.

Figures 5-6 through 5-13 show the layout of the seven (7) printed circuit boards with respective jumper blocks, where applicable, used in the meter. Figures 5-8 through 5-12 show the optional boards.

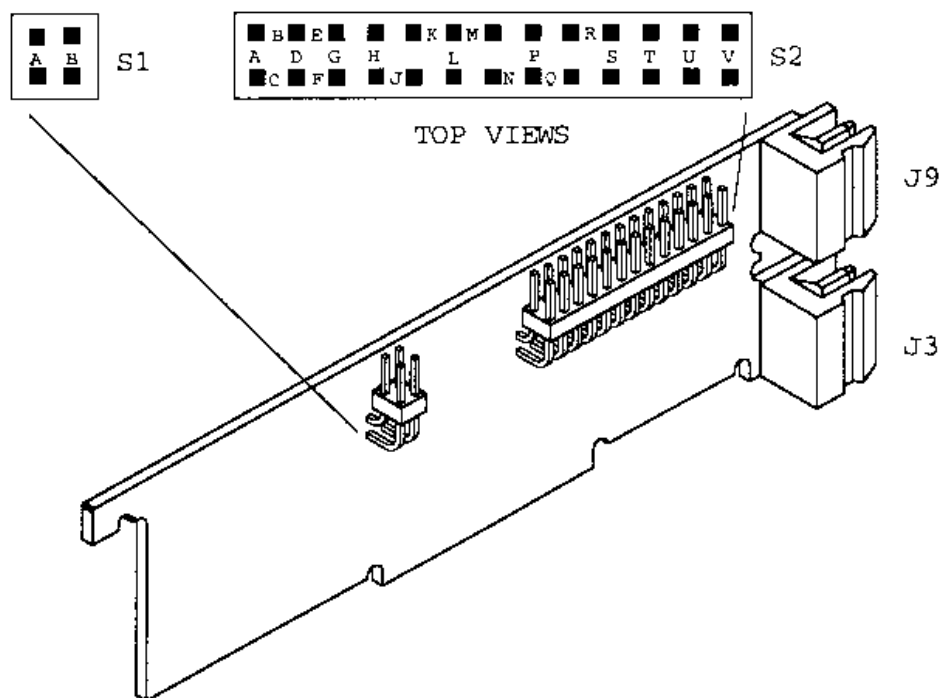

Figure 5-6. Signal Input Board

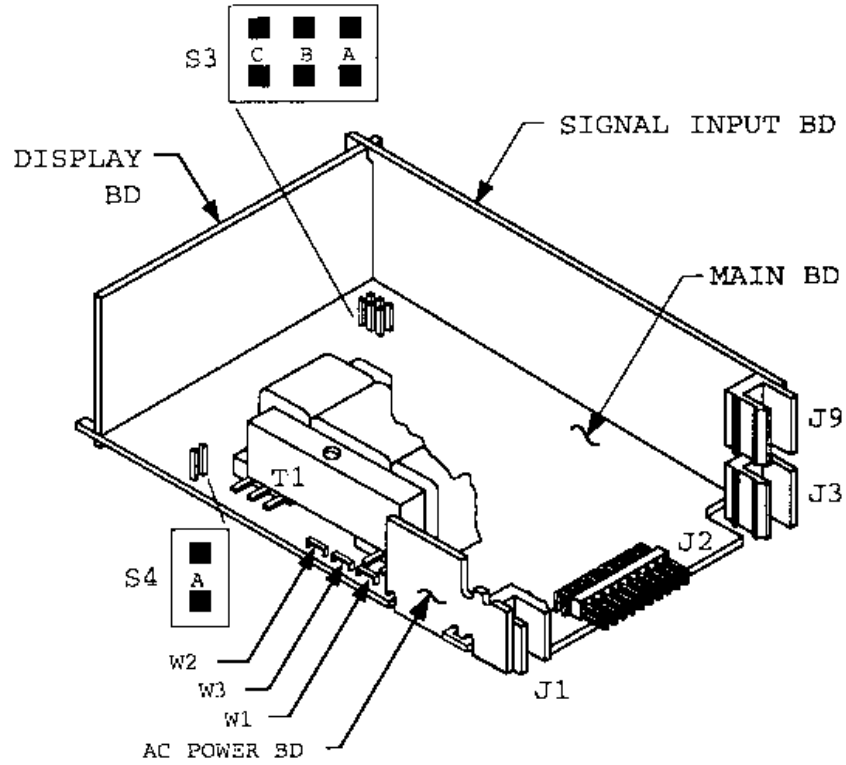

Figure 5-7. Main Board

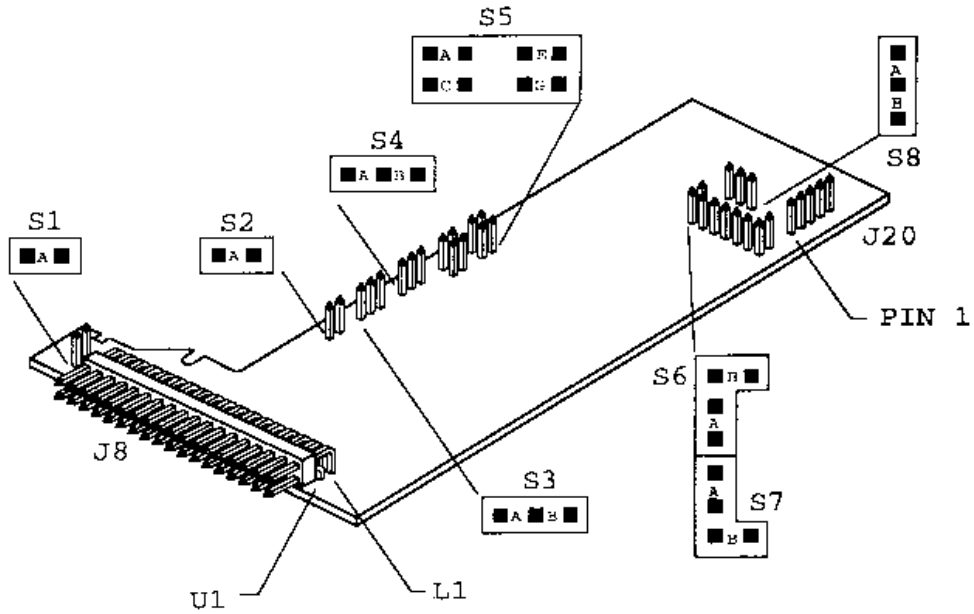

Figure 5-8. BCD Option Board

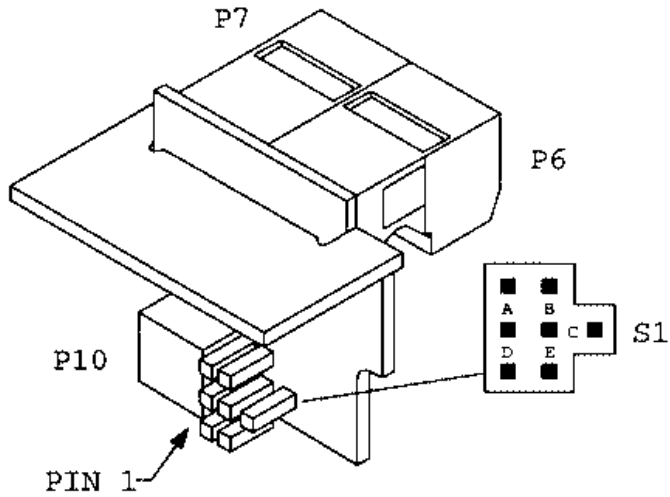

Figure 5-9. Relay Option Board

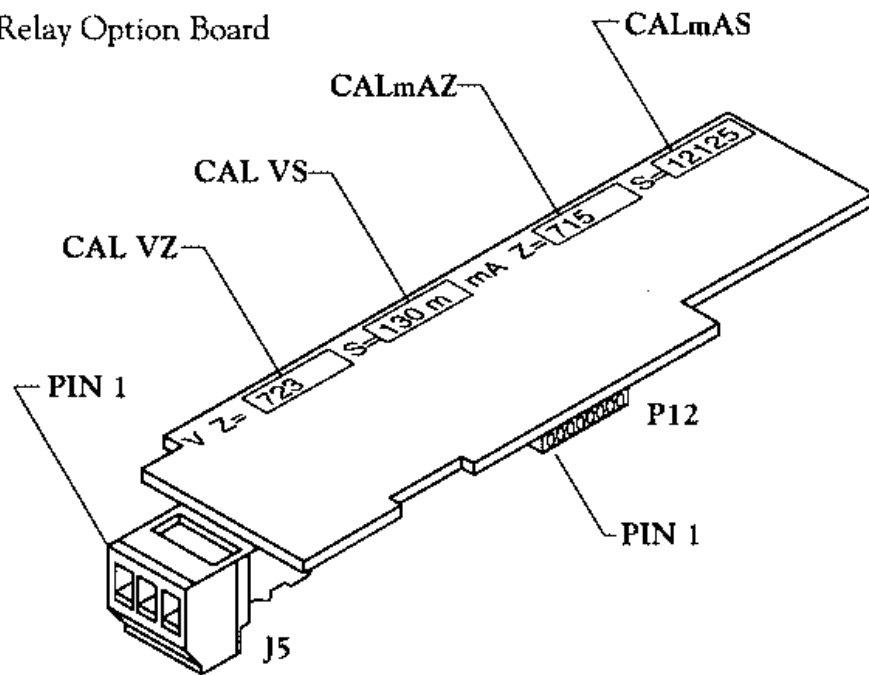

Figure 5-10. Analog Output Option Board

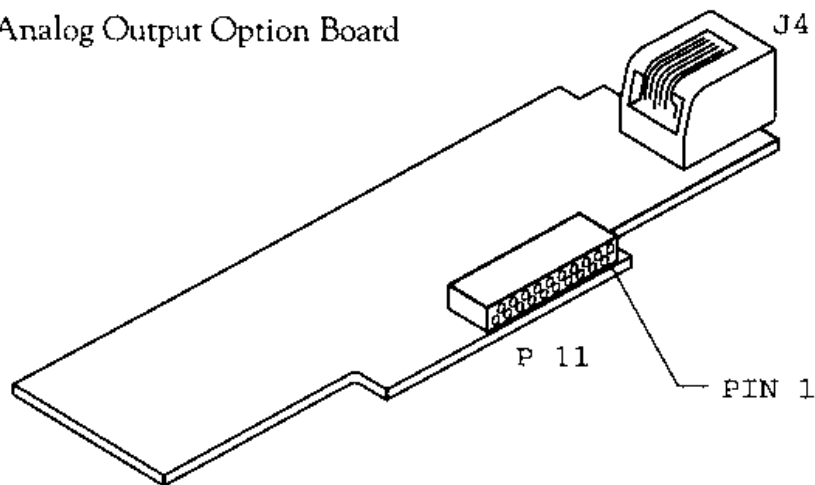

Figure 5-11. RS-232 Option Board

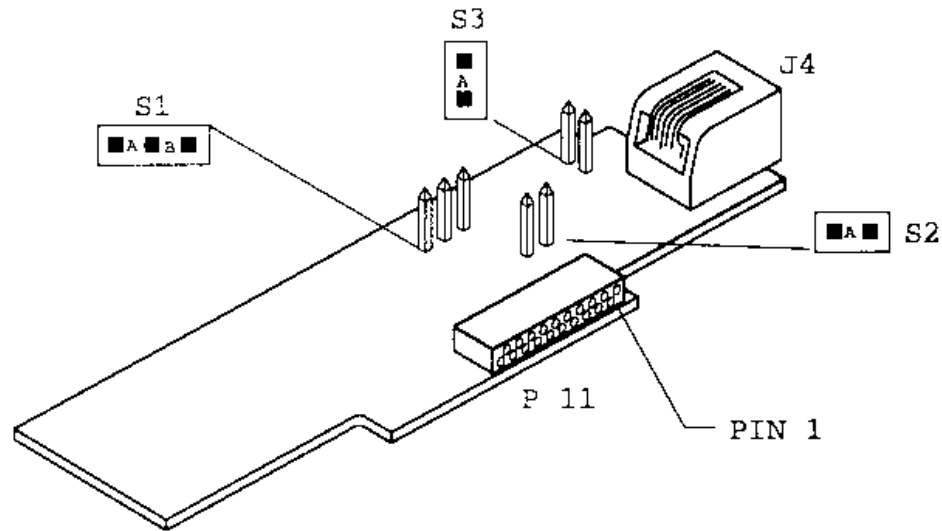

Figure 5-12. RS-485 Option Board

5.2.5 PANEL MOUNTING

To mount the meter in a panel:

1. "Reveal the Main Board" (refer to Section 5.2, Disassembly).
You don't need to do step 7.
2. Using the panel cutout diagram shown in Figure 5-13, cut a hole in the panel.

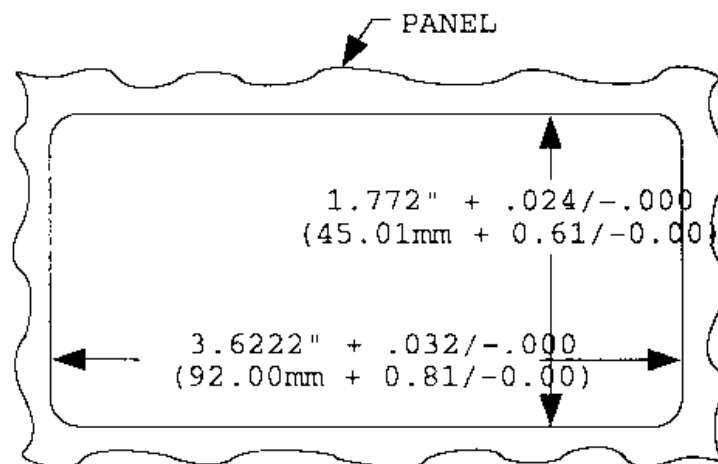

Figure 5-13. Panel Cutout Dimensions

3. Insert the case and meter into the hole, so that the gasket seals between the bezel and the front of the panel.
Refer to Figure 5-14.
4. Slip the sleeve over the rear of the case.

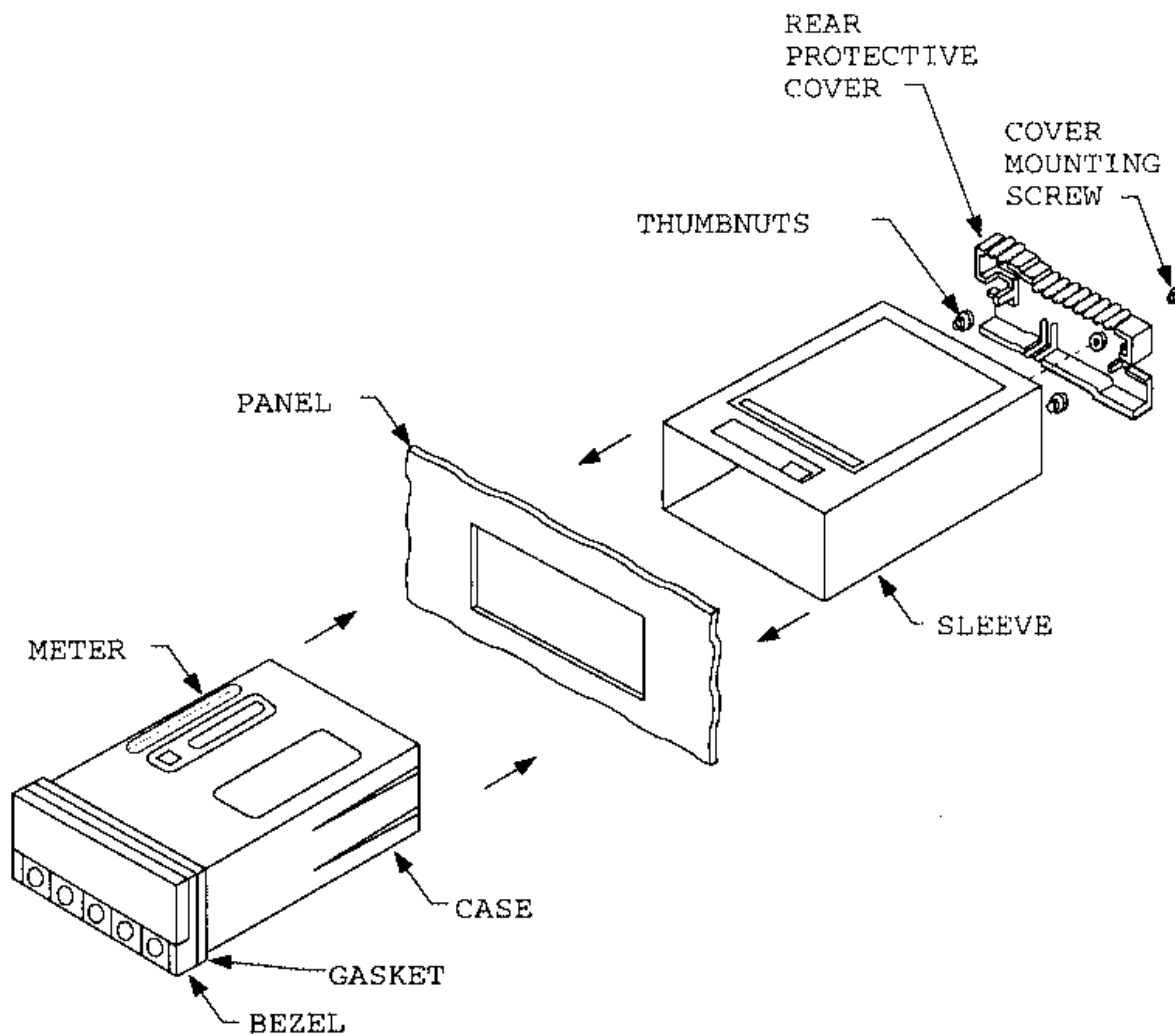

Figure 5-14. Panel Mounting

5. Re-attach and tighten the thumbnuts to hold the meter firmly in the panel.
6. Replace the wire connectors at the rear of the meter.
7. Replace the applicable rear protective cover and secure with the cover mounting screw.
8. Re-apply power. Section 5.3 covers how to wire the power connector, if you haven't already done so.

The meter display should light, and pass through "RESET 2" to run or display mode. If the meter flashes an overscale or overload message, press the 'MENU' button to advance to the configuration mode. Do not be concerned about overloads (the +S input can stand 120 V continuously and current inputs can handle ten times rated current).

5.2.6 BENCH TOP USE

The sleeve has no mounting function in bench-top use, but covers the input-jumper opening and provides additional protection. Attach the appropriate wires to the signal connectors P3, P9 (and the Cold-Junction Compensation board, if used) and plug them in to the rear of the assembly. The label on the case sleeve shows the connectors and terminal designators.

Attach the rear protective cover with the cover mounting screw. Plug in the power connector: the meter should light, and display "RESET 2", then return to the run mode. If the meter flashes an overscale or overload message refer to Section 17, Troubleshooting Guide. Do not be concerned about overloads (the +S input can stand 120 Vac continuously and current inputs can handle ten times rated current).

5.3 AC WIRING

The orange (power) connector must be wired according to the following procedure (refer to Figure 5-15):

USA WIRING CODE	INTERN'L WIRING CODE	CONNECTION	PIN # ON ORANGE CONNECTOR
Black	Brown	AC High (HI)	1
White	Blue	AC Neutral(LO)	2
Green	Green/Yellow	AC Ground	3

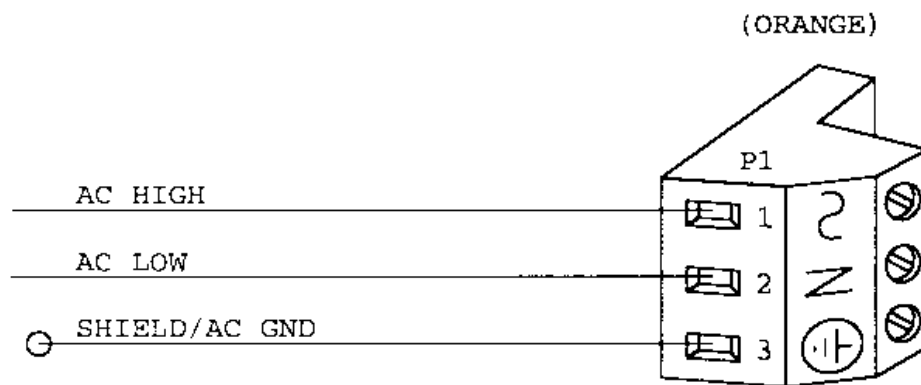

Figure 5-15. AC Connector Wiring

5.4 COLD JUNCTION COMPENSATION BOARD INSTALLATION FOR THERMOCOUPLES

To setup the rear protective cover with the P3 and P9 connectors (and Cold-Junction Compensation Board), proceed with the following (Refer to Figure 5-16):

1. Obtain P3 and P9 connectors and the thermocouple rear protective cover.
2. Put the two (2) connectors P3 and P9 into the corresponding male connectors at the rear of the meter. Refer to Figure 4-2 for the location of the male connectors. P3 and P9 are identical and interchangeable connectors.
3. Using a long slotted screwdriver (one that is at least 4" long), loosen the 6 screws on the connectors.
4. Carefully install the thermocouple rear protective cover onto the connectors making sure the pins in the rear cover make good contact with the holes in the connectors.
5. Tighten the 6 screws (do not over tighten).
6. Fasten down the cover with the cover mounting screw.

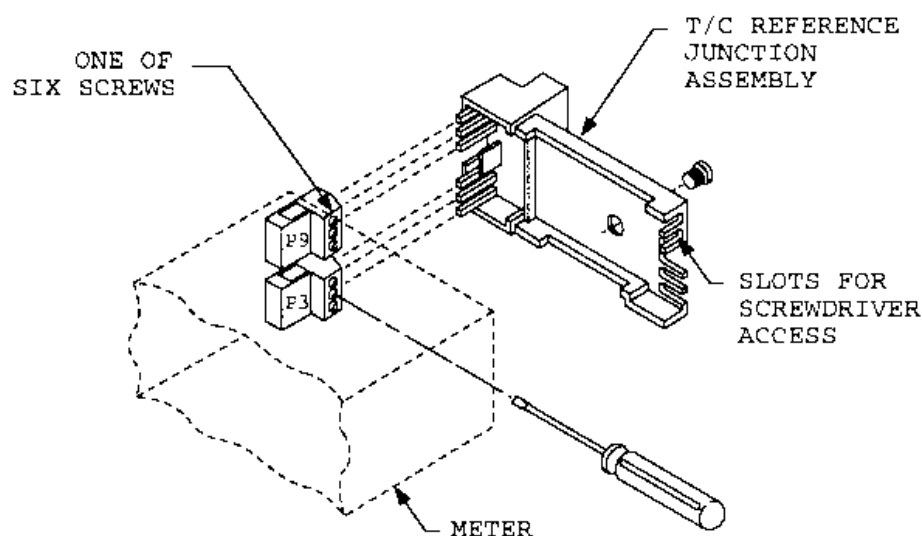

Figure 5-16. Installation of Thermocouple Cold-Junction Compensation Board Assembly

5.4.1 COLD-JUNCTION COMPENSATION BOARD WIRING

Figure 5-17 shows the wiring hookup for thermocouples. Use the following table to determine which colored wires get connected to the positive and negative terminals. Note: positive and negative wiring designations are molded into the plastic cover.

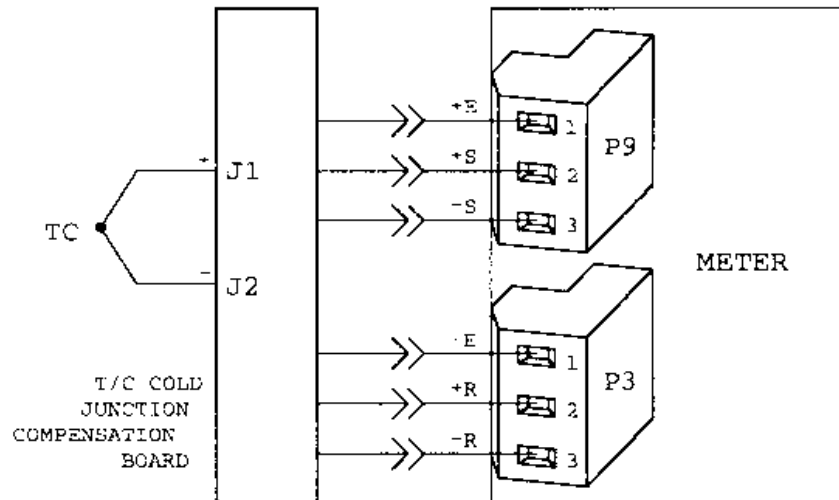

Figure 5-17. Directly-Connected Thermocouple

5.4.2 THERMOCOUPLE WIRE COLORS

TABLE 5-1. THERMOCOUPLE WIRE COLORS

T/C TYPE	USA	
	+ LEAD	- LEAD
J	White	Red
K	Yellow	Red
T	Blue	Red
E	Purple	Red
N	Orange	Red
R	Black	Red
S	Black	Red
B	Grey	Red
DIN J	Red	Blue

FRANCE			GERMANY	
T/C TYPE	WIRE COLORS		WIRE COLORS	
	+ LEAD	- LEAD	+ LEAD	- LEAD
J	Yellow	Black	Red	Blue
K	Yellow	Purple	Red	Green
T	Yellow	Blue	Red	Brown
E	Yellow	Purple	Red	Black
N	No Standard-See USA		No Standard-See USA	
R	Yellow	Green	Red	White
S	Yellow	Green	Red	White
B	Use Copper Wire		Red	Gray
DIN J	Red	Blue	Red	Blue

JAPAN			UNITED KINGDOM	
T/C TYPE	WIRE COLORS		WIRE COLORS	
	+ LEAD	- LEAD	+ LEAD	- LEAD
J	Red	White	Yellow	Blue
K	Red	White	Brown	Blue
T	Red	White	White	Blue
E	Red	White	Brown	Blue
N	No Standard-See USA		No Standard- See USA	
R	Red	White	White	Blue
S	Red	White	White	Blue
B	Red	Gray	No Standard- See USA	
DIN J	Red	Blue	Red	Blue

Once you have installed all applicable printed circuit boards in the meter and mounted the meter in your panel (if desired), and wired the meter, you can proceed to:

Section 6 for an example of how to operate the meter with a Type K thermocouple.

Or

Section 7 for an example of how to operate the meter with an RTD.

Or

Section 8 for details on how to hook up a non-linear transmitter.

This page is intentionally left blank

6. Type K Thermocouple Setup Example

6.1 INTRODUCTION

This section provides you with details on how to set up and use your meter with a Type K thermocouple. The typical factory preset thermocouple type will be a Type K. However, YOUR factory setup may be different. If you want to change these characteristics of the meter, refer to Sections 6.6 and 6.7. Follow these steps to ensure the meter will operate properly:

METER'S FACTORY PRESET CHARACTERISTICS

Units of measurement in Degrees Fahrenheit,
Display on the meter °F, and 0.1 degree resolution
115 V ac powered (unless 230 V ac ordered).

1. Attach power wires to the power connector (orange) and attach to the rear of the meter. Refer to Section 6.4.
2. Attach the Cold-Junction Compensation Board and rear protective cover assembly to the meter. Refer to Section 6.3.
3. Attach thermocouple wires to the rear protective cover. Refer to Section 6.5.
4. Power up the meter and verify operation.

6.2 JUMPER INFORMATION

S1, S2, and S3 are factory configured as shown in Figures 6-1 and 6-2.

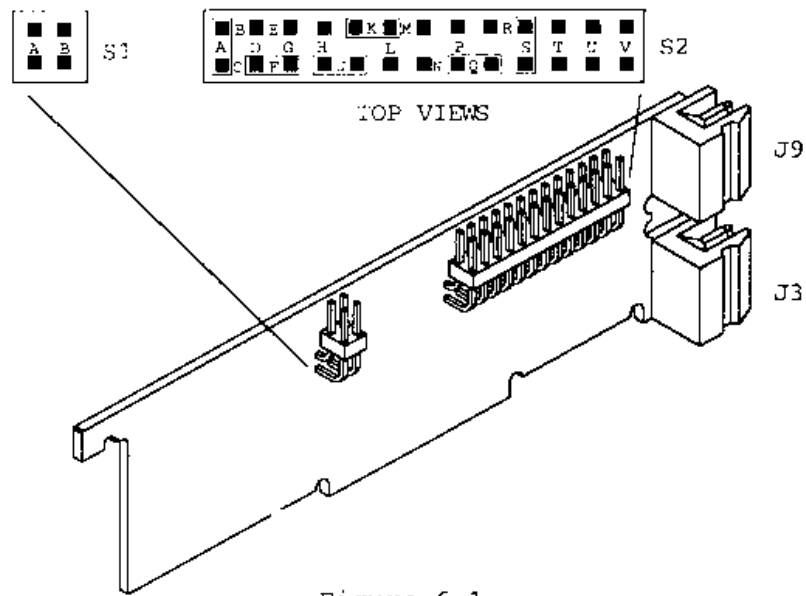

Figure 6.1

Figure 6-1. Signal Input Board Jumper Diagram with S1 and S2 Jumpers

JUMPER	BOARD	NOTES
no S1A*	Input	Slower (3/sec) reading rate
no S1B**	Input	Unipolar input range
S2A & S2F	Input	-10 to +110 mV range
S2J & S2K	Input	Connects Cold-Junction Compensation
S2Q	Input	Adds 1.25 V excitation
S2S	Input	Upscale Open-TC Indication

* Software switch "INP.2" must also be set to "=0".

** Software switch "INP.3" must also be set to "=0".

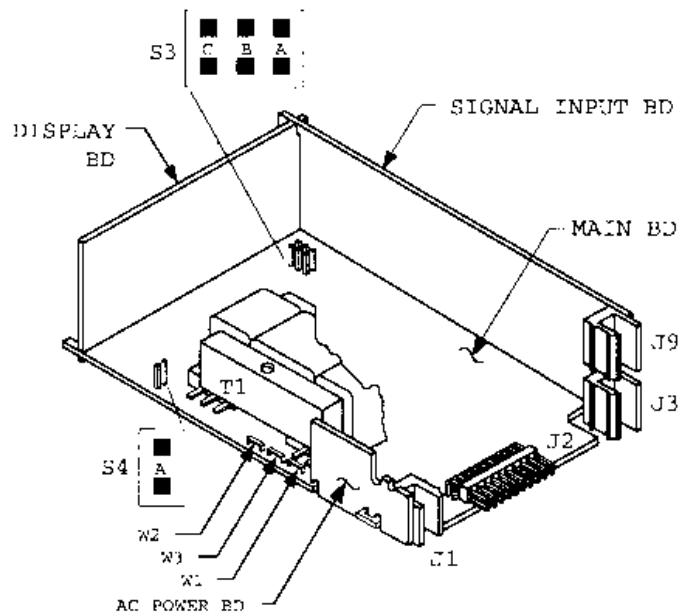

Figure 6-2. Main Board with S3 and S4 Jumpers

JUMPER	BOARD	NOTES
S3A	Main	Unlocks button programming
S3C	Main	Unlocks Lockout menu programming

Typically, you would not require a read rate faster than 3 per second (thermocouples are typically slow in responding to temperature changes). However, you may select a faster read rate of 12 per second by installing a jumper in "S1A" on the Signal Input Board and changing the software selection in "IN CNF" (Input Configuration) to read "INP.2=1".

S2A, S2F, S2J, S2K, S2Q block out the input attenuator and do not insert any offset, thereby using the meter's basic 100 mV range. They also connect the meter's curvilinear cold-junction compensation circuit to the input. For upscale open sensor indication with an open thermocouple, use jumper S2S (for downscale, use S2R).

WARNING: Failure to complete both the hardware and software changes will result in erroneous readings.

6.3 COLD JUNCTION COMPENSATION BOARD INSTALLATION

To setup the rear protective cover with the P3 and P9 connectors (and Cold-Junction Compensation Board), go through the following (Refer to Figure 6-3):

1. Obtain P3 and P9 connectors and the thermocouple rear protective cover.
2. Put the two (2) connectors P3 and P9 into the corresponding male connectors at the rear of the meter. Refer to Figure 4-2 for the location of the male connectors. P3 and P9 are identical and interchangeable connectors.
3. Using a long slotted screwdriver (one that is at least 4" long), loosen the 6 screws on the connectors.
4. Carefully install the thermocouple rear protective cover onto the connectors making sure the pins in the rear cover make good contact with the holes in the connectors.
5. Tighten the 6 screws (do not over tighten!).

- Carefully remove the rear protective cover WITH the P3 and P9 connectors attached to it and set aside. Continue to Section 6.4 for AC wiring.

NOTE: DO NOT ATTACH THE REAR COVER TO THE METER WITH THE COVER MOUNTING SCREW UNTIL YOU FIRST INSTALL THE P1 POWER CONNECTOR IN THE REAR OF THE METER.

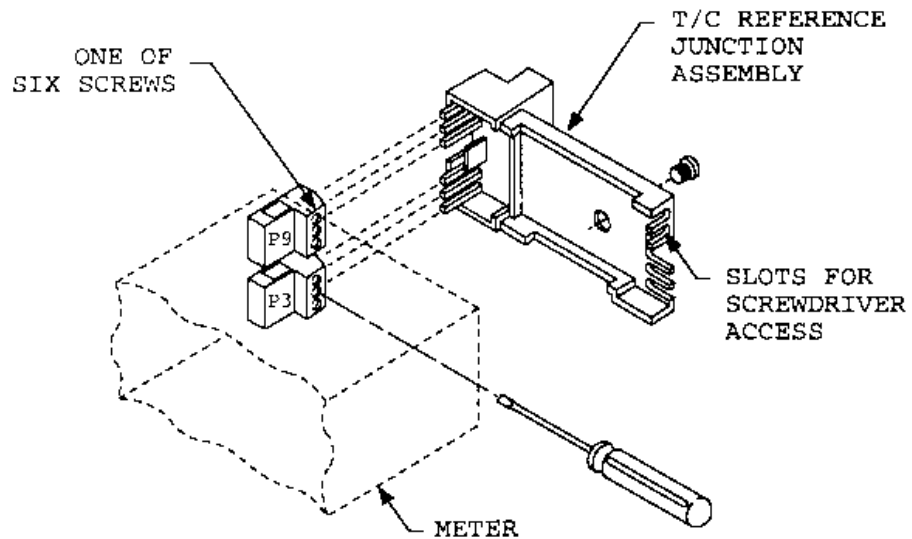

Figure 6-3. Installation of Cold-Junction Compensation Board Assembly

6.4 AC WIRING

- Wire the orange power connector (P1) using the AC wiring information listed below.

USA WIRING CODE	INTERN'L WIRING CODE	CONNECTION	PIN # ON ORANGE CONNECTOR
Black	Brown	AC High (HI)	1
White	Bluc	AC Neutral(LO)	2
Green	Green/Yellow	AC Ground	3

- Insert the orange power connector, which you just wired, into the connector located at lower left rear of the meter. Refer to Figure 6-4 for the location of P1.

3. CAREFULLY install the rear protective cover assembly (with the P3 and P9 connectors) onto the rear of the meter making sure you have a good fit between the P3 and P9 male and female connectors.
4. Fasten the rear protective cover with the cover mounting screw. Continue to Section 6.5 for Cold-Junction Compensation Board Wiring.

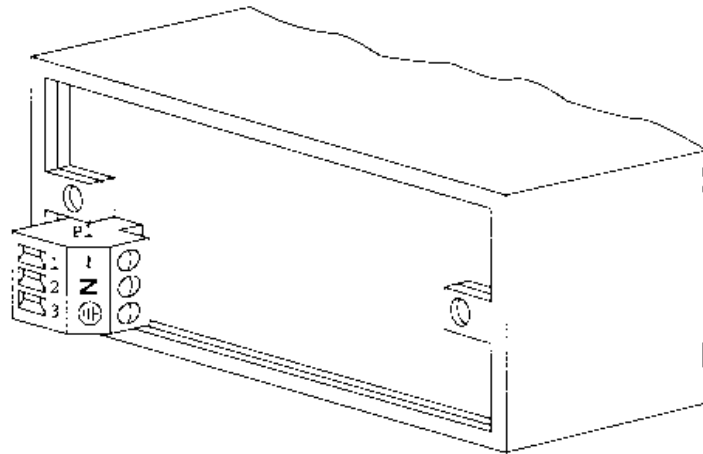

Figure 6-4. Rear View of the Meter

6.5 COLD-JUNCTION COMPENSATION BOARD WIRING

Figure 6-5 shows the wiring hookup for any thermocouple type. For Type K, hook up the yellow wire to the + terminal and the red wire to the - terminal on the rear protective cover. Notice that the cover has positive and negative wiring designations molded into the plastic.

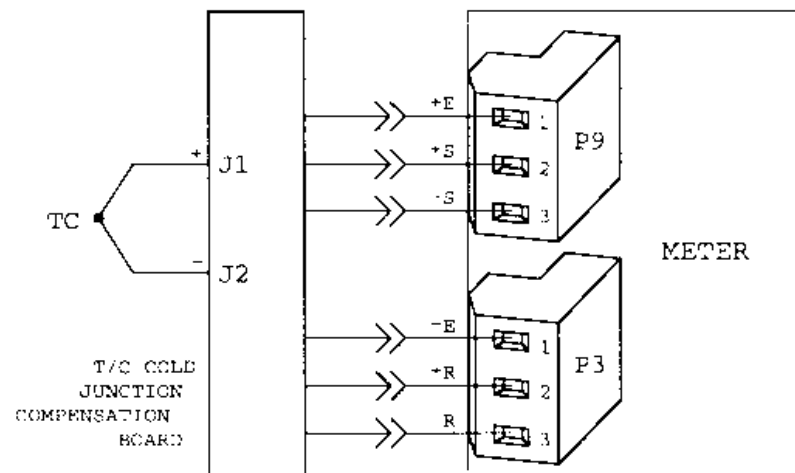

Figure 6-5. Directly-Connected Thermocouple

Sections 6.6 and 6.7 provide details on how to change the characteristics of your meter (for example: you want to change to a Type J thermocouple and/or you want to measure in $^{\circ}\text{C}$, etc.)

6.6 RE-CONFIGURING THE METER FOR OTHER CHARACTERISTICS

Make sure the meter is set up according to the steps in Section 6.1.

6.6.1 TO SELECT THERMOCOUPLE TYPE

PRESS	THEN PRESS (TO CHANGE IF REQUIRED)	UNTIL DISPLAY SHOWS	COMMENTS
'MENU'		"INPUT"	You need the display to show "INPUT".
'MIN'	'MAX'	"TC"	Press the 'MIN' button to have the meter display (flashing) an input type. Press the 'MAX' button to select TC.
'MENU'		"STORED" then "TC"	Display will most often momentarily show "STORED" and then show "TC".
NOTE: In each and every case where the parameter is changed and then the 'MENU' button is pressed, the display will show "STORED". To simplify matters, "STORED" is not shown in the future but is understood.			
'MIN'	'MAX'	The input type of your choice	Press the 'MIN' button to have the meter display a signal type. Press the 'MAX' button to select either Type J, K, T, E, N, R, S, B, or DNJ. (Make sure the proper thermocouple type is connected to your meter).

NOTE: Thermocouple wire colors are listed in Section 5.4.2 so you can wire your meter accordingly.

6.6.2 TO SELECT THE UNITS OF MEASUREMENT

PRESS	THEN PRESS (TO CHANGE IF REQUIRED)	UNTIL DISPLAY SHOWS	COMMENTS
'MENU'		"RDG.CNF"	Stores signal type. Setup reading configuration.
'MIN'	'MAX'	"RDG.5=0", "RDG.5=1", or "RDG.5=2"	Determine the units of measure to be used: degrees C (if "=0"), degrees F (if "=1") K (if "=2"). By pressing the 'MIN' button 5 times, the meter advances to RDG.5. The 'MAX' button allows you to change the "0", "1" or "2".

6.6.3 TO SELECT WHETHER TEMPERATURE UNITS ARE DISPLAYED

PRESS	THEN PRESS (TO CHANGE IF REQUIRED)	UNTIL DISPLAY SHOWS	COMMENTS
'MIN'	'MAX'	"RDG.6=0" or "RDG.6=1"	Determine whether the temperature units is NOT to be displayed (if "=0") or if the temperature units is to be displayed (if "=1"). By pressing the 'MIN' button again, the meter advances to "RDG.6". The 'MAX' button allows you to change the "0" or "1".
'MENU'		"RDG SC" or "RD.SC.OF"	Stores "RDG.6" selection. Advance to "RDG SC" or "RD.SC.OF".

6.6.4 TO SELECT THE DISPLAY RESOLUTION

PRESS	THEN PRESS (TO CHANGE IF REQUIRED)	UNTIL DISPLAY SHOWS	COMMENTS
'MENU'		"DEC PT"	Advance to DEC PT (you don't need "RDG SC" or "RD.SC.OF").
'MIN'	'MAX'	"FFFFFF", "FFFFFF.F" or "FFFF.FF"	Determine where you want the decimal point. By pressing the 'MIN' button, the meter displays the previously selected decimal point location within the "F's" or the factory preset location. The 'MAX' button allows you to change the location of the decimal point.
'MENU'		"CNT BY"	Stores the decimal point location and the display will show "CNT BY".
'RESET' 'RESET'		Measured	Press the 'RESET' button two times. The display momentarily shows "RUN" and then the currently measured values

NOTE: The choice of decimal point location is restricted to a display resolution of whole degrees, tenths, or hundredths of a degree.

6.7 COLD JUNCTION COMPENSATION OFFSET PROCEDURE

The meter has been calibrated with the cold-junction compensation board included with your unit. If you change the board or want to verify the calibration, proceed with the procedure in Section 6.7.1.

6.7.1 SET THERMOCOUPLE ZERO

In order to set thermocouple zero you must complete the following steps:

PRESS	THEN PRESS (TO CHANGE IF REQUIRED)	UNTIL DISPLAY SHOWS	COMMENTS
'MENU'		"C.JUN.OF"	This is the cold-junction compensation main menu.
'MAX'		"XXXXX"	Display will show the cold-junction offset number.
	'MIN' & 'MAX'	"00000"	Using the 'MIN' and 'MAX' buttons enter all zeros ("00000") on the display.
'MENU'			Press the 'MENU' button to store the change(s) and the meter will return to the run mode.

NOTE: You must verify that the "DEC PT" is set to a resolution of 0.0 (tenths).

Now you must record the actual offset reading by using one of the following procedures:

Connect the proper thermocouple type to the meter and place the thermocouple into an ice point cell. After the reading on the display has stabilized, record the displayed offset (T) and proceed with the "C.JUN.OF" calculation formula.

or

Connect a thermocouple calibrator and set the input for icepoint 0°C or 32°F. After the reading on the display has stabilized, record the displayed offset (T) and proceed with the "C.JUN.OF" calculation formula.

Calculate the "C.JUN.OF" cold junction offset number to be entered into the meter by using one of the following formulas:

T= your recorded display with ice point input

For °F: $(T-32.0) \times 150 = \text{offset number}$

For °C: $T \times 270 = \text{offset number}$

Note: If your offset number is a positive number, just enter it,
or

If your offset number is zero, enter all zeros into the meter

If your offset number is a negative number disregard the negative sign and add the value to 32767 and enter this number into your meter.

Example: If your calculated offset number was "-122" then you would add your calculated value of "122" to "32767", which equals "32889". Enter this number into your meter.

6.7.2 SPECIAL COLD-JUNCTION CALIBRATION

In order to assure the specified accuracy for measurements below -40 degrees, you must first apply a negative millivolt input signal to your meter (to determine the error), record the reading, then complete the following calculation:

-FS = a temperature within 5 degrees of the maximum negative temperature of any thermocouple type in °C or °F range.

Icepoint= 0.0°C (32.0°F)

Sensitivity at -FS= ΔmV input for $\Delta 1^\circ C$ ($^\circ F$)

Sensitivity at Icepoint= $\Delta \mu V$ input for $\Delta 1^\circ C$ ($^\circ F$)

$$T = \text{error at -Full Scale} \times \frac{\text{Sensitivity at -FS}}{\text{Sensitivity at icepoint}}$$

T= Error at negative full scale (-FS) times sensitivity at negative full scale (-FS) divided by sensitivity at icepoint 0.0°C (°F).

An Example would be as follows:

-270 °C Type K input
Display reads -266.1°C
Error equals 3.9 °C

continued on next page

continued from previous page

$$T = \frac{3.9 \times 1\mu\text{V}/^\circ\text{C}}{39 \mu\text{V}/^\circ\text{C}} = 0.1^\circ\text{C}$$

$$T = 0.1^\circ\text{C}$$

$$\text{Offset number} = 0.1 \times 270 = 27$$

WARNING: Before entering your offset number you must first complete the SET THERMOCOUPLE ZERO procedure as described in Section 6.7.1.

If meter displays “-OPEN”, reduce -FS input 5 degrees.

TO ENTER YOUR COLD-JUNCTION OFFSET NUMBER,
YOU MUST COMPLETE THE FOLLOWING PROCEDURE:

PRESS	THEN PRESS (TO CHANGE IF REQUIRED)	UNTIL DISPLAY SHOWS	COMMENTS
'MENU'		"C.JUN.OF"	This is the cold-junction compensation main menu.
'MAX'		"00000"	Display will show the cold-junction offset number "00000" which was entered earlier.
	'MIN' & 'MAX'	"XXXXX"	Using the 'MIN' and 'MAX' buttons enter your calculated cold-junction offset number into the meter.
'MENU'			Press the 'MENU' button to store your entry and the meter will return to the run mode.

continued on next page

continued from previous page

If you have a non-linear transmitter hooked up to your meter, refer to Section 8 for details.

If there are other characteristics you want to change, refer to Section 9 for full details.

After you have completed your programming, you may want to go back and remove the jumper in S3A position on the main board to insure against any unauthorized changes or refer to specific lockout functions (software) in Section 9.

7. 3-Wire 100 OHM Platinum (Din) RTD/Ohms Setup Example

Section 7 is divided into two parts:

- 1) 3-wire, 100 Ω platinum RTD, and
- 2) 4-wire, 10 Ω copper RTD.

7.1 3-WIRE 100 OHM PLATINUM RTD INFORMATION

This section provides you with details on how to set up and use your meter with a 3-wire 100 Ω platinum (DIN) RTD. Other factory preset characteristics are listed below. Proceed through the following steps in order to assure your meter operates correctly.

METER'S FACTORY PRESET CHARACTERISTICS

Units of measurement in degrees Fahrenheit,
Display on the meter $^{\circ}\text{F}$, and 0.1 degree resolution and 115 V ac
power (unless you ordered 230 V ac)

1. Connect the RTD to P3 and P9 connectors. Refer to Figure 7-3.
2. Attach power wires to the power connector (orange) and attach to the rear of the meter. Refer to Section 7.4.
3. Power up the meter, observe readings and verify operation.

NOTE: IF YOU HAVE A LINEAR 2-, 3-, OR 4-WIRE RTD, (SUCH AS 4-WIRE, 10 Ω COPPER) YOU WILL NEED TO FOLLOW SECTION 7.7.

7.2 JUMPER INFORMATION

S1, S2, S3, and S4 are factory configured as follows (Refer to Figures 7-1 and 7-2):

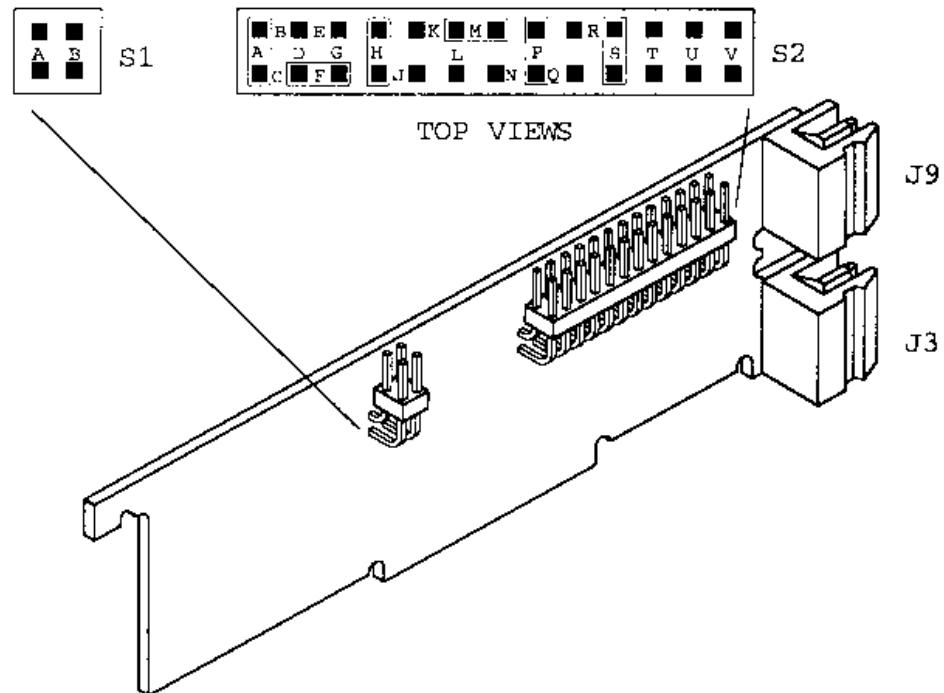

Figure 7-1. Signal Input Board Jumper Diagram with S1 and S2 Jumpers

JUMPER	BOARD	NOTES
no S1A*	Input	Slower (3/sec) read rate
no S1B**	Input	Unipolar input
S2A & S2F	Input	-10 to 110 mV range (factory configuration)
S2A & S2D	Input	-0.1 to 1.1V range for RTD or resistances over 600 Ω
S2H	Input	For 3- or 4-wire RTD's
no S2K, L	Input	No aux. divider
S2M	Input	2-wire measurement
S2P	Input	Connect 160 mA current source
S2V	Input	Install if RTD less than 60 Ω 's
S2S	Input	Upscale open-sensor indication

* Software switch "INP.2" must also be set to "=0".

** Software switch "INP.3" must also be set to "=0".

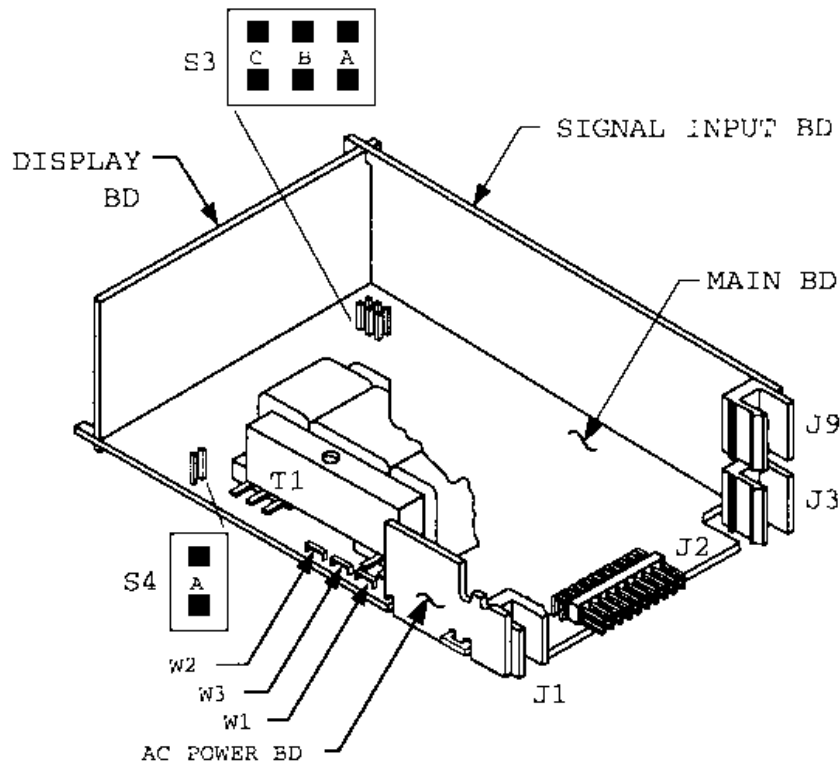

Figure 7-2. Main Board with S3 and S4 Jumpers

JUMPER	BOARD	NOTES
S3A	Main	Unlocks pushbutton programming
no S3B	Main	Meter calibration locked out
S3C	Main	Unlocks lockout menus
no S4A	Main	Not applicable, selects 10 or 24 V dc sensor excitation

7.3 INPUT CONNECTIONS

Figure 7-3 shows the input connections and input-connector jumper needed for 3-wire RTD. This (most popular) connection works best with RTD/Ohms leads which are closely equal in resistance. The meter measures the RTD plus upper and lower lead drop voltage and then subtracts twice the measured drop in the lower supply current lead, producing excellent lead-resistance cancellation for balanced measurements.

3-wire measurement lowers the measurement rate by approximately

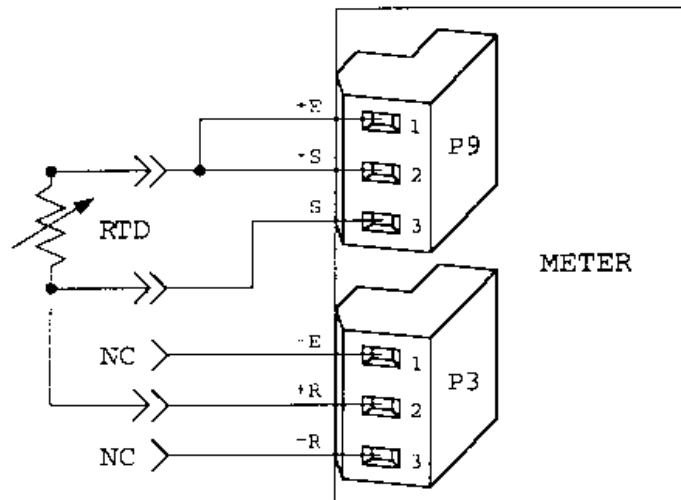

twenty (20) percent.

Figure 7-3. 3-Wire RTD

7.4 AC WIRING

Setup the meter using the AC wiring information listed below:

USA WIRING CODE	INTERN'L WIRING CODE	CONNECTION	PIN # ON ORANGE CONNECTOR
Black	Brown	AC High (HI)	1
White	Blue	AC Neutral(LO)	2
Green	Green/Yellow	AC Ground	3

1. Insert the P1 connector at the rear of the meter. Refer to Figure 7-4 for the location of P1.
2. Insert P3 and P9 in the male pins.
3. Put the rear protective cover onto the rear of the meter.
4. Fasten down the rear protective cover with the cover mounting screw.

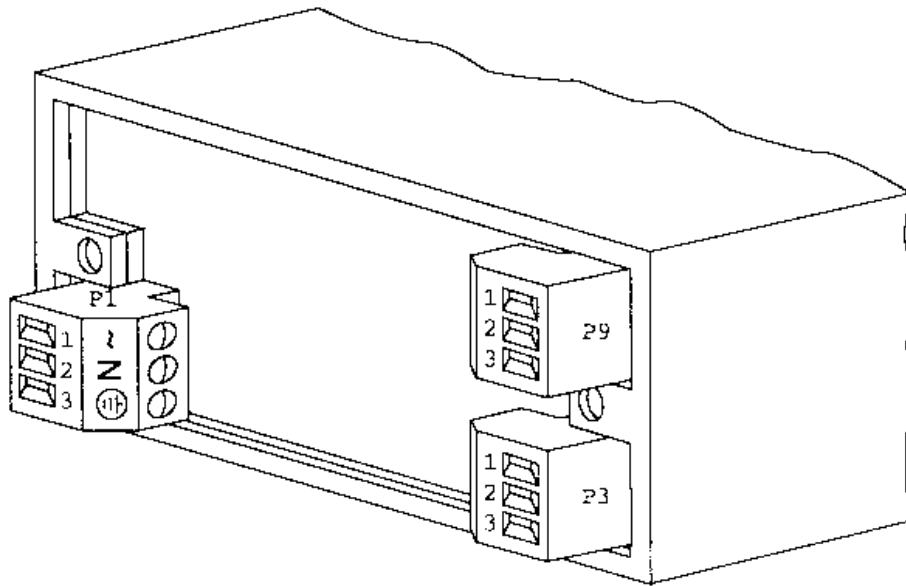

Figure 7-4. Rear View of the Meter

Sections 7.5 and 7.6 provide details on how to change the characteristics of your meter (for example, you have 2-wire NIST RTD, or want to measure in $^{\circ}\text{C}$, etc.)

7.5 RE-CONFIGURING THE METER FOR OTHER CHARACTERISTICS

7.5.1 TO SELECT RTD TYPE

Make sure the meter is setup according to the 3 steps in Section 7.1.

PRESS	THEN PRESS (TO CHANGE IF REQUIRED)	UNTIL DISPLAY SHOWS	COMMENTS
'MENU'		"INPUT"	You need the display to show "INPUT".
'MIN'	'MAX'	"RTD"	Press the 'MIN' button to have meter display (flashing) an input type. Press the 'MAX' button to select RTD.
'MENU'		"STORED" the "RTD"	Display will momentarily show "STORED" (only "RTD" when a change has been made) and then show "RTD".
<p>NOTE: in each and every case where the parameter is changed and then the 'MENU' button is pressed, the display will show "STORED". To simplify matters, "STORED" is not shown in the future but is understood.</p>			
'MIN'	'MAX'	Your Input choice	Press the 'MIN' button to have the meter display show a signal type. Press the 'MAX' button to select either 2PT392, 3PT392, 4PT392, 2PT385, 3PT385, 4PT385 or LINEAR.

7.5.2 SELECT THE UNITS OF MEASUREMENT

PRESS	THEN PRESS (TO CHANGE IF REQUIRED)	UNTIL DISPLAY SHOWS	COMMENTS
'MENU'		"RDG.CNF"	Set reading configuration
'MIN'	'MAX'	"RDG.5=0", "RDG.5=1", or "RDG.5=2"	Determine the units of measure to be used: °C (if "=0"), °F (if "=1") or K (if "=2"). By pressing the 'MIN' button 5 times, the meter advances to "RDG.5". The 'MAX' button allows you to change the "0", "1" or "2".

7.5.3 TO SELECT TEMPERATURE UNITS

PRESS	THEN PRESS (TO CHANGE IF REQUIRED)	UNTIL DISPLAY SHOWS	COMMENTS
'MIN'	'MAX'	"RDG.6=0" or "RDG.6=1"	Determine whether the Temperature units is NOT to be displayed (if "=0") or if the Temperature Units is to be displayed (if "=1"). By pressing the 'MIN' button again, the meter advances to "RDG.6". The 'MAX' button allows you to change the "0" or "1".
'MENU'		"RDG SC" or "RD.SC.OF"	Stores "RDG.CNF". Advance to "RDG SC" or "RD.SC.OF".

7.5.4 TO SELECT THE DISPLAY RESOLUTION

PRESS	THEN PRESS (TO CHANGE IF REQUIRED)	UNTIL DISPLAY SHOWS	COMMENTS
'MENU'		"DEC PT"	Bypass "RDG SC" or "RD.SC.OF". Advance to "DEC PT".
'MIN'	'MAX'	"FFFFFF." or "FFFFFF.F" or "FFFF.FF"	Determine where you want the decimal point. By pressing the 'MIN' button, the meter displays the previously selected decimal point location within the "Fs" or the factory preset location. The 'MAX' button allows you to change the location of the decimal point.
'MENU'		"CNT BY"	To store decimal point location. Advance to "CNT BY".
'RESET', 'RESET'		Measured Values	Press the 'RESET' button two times. The display momentarily shows "RUN" and then the currently-measured values.

NOTE: the choice of decimal point location is restricted to a display resolution of whole degrees, tenths, or hundredths of a degree.

After you have completed your programming, you may want to go back and remove the jumper in S3A position on the Main Board to insure against any unauthorized changes or refer to specific lockout functions (software) in Section 9.

7.6 2-WIRE AND 4-WIRE RTD WIRING

Figure 7-5 shows the input connections and input-connector jumpers required for hookup of a 2-wire RTD (resistor). 2-wire connection is the simplest, but does not compensate for lead-wire temperature change and often requires calibration to cancel lead-wire resistance offset.

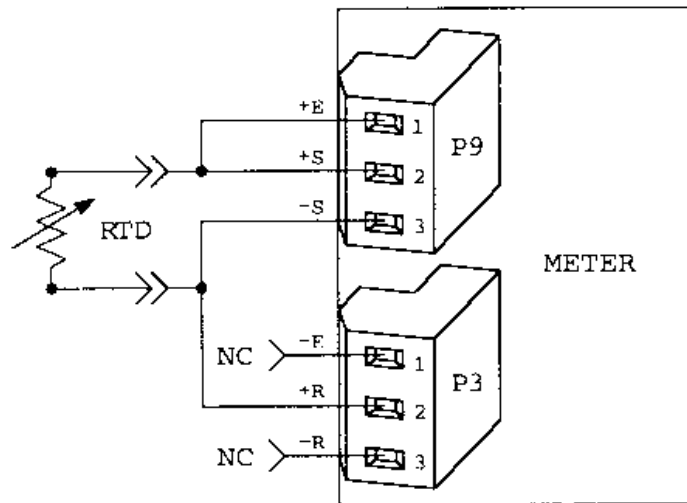

Figure 7-5. 2-Wire RTD

Figure 7-6 shows the input connections for 4-wire RTD (or ohmmeter, if "INP.5=1" was selected) hookup, applicable to low-ohm sensors or to unbalanced lead resistances. The fourth wire enables the meter to measure the RTD-plus-lower-lead-drop voltage and then to measure and subtract that lead voltage; this produces the best lead-resistance cancellation.

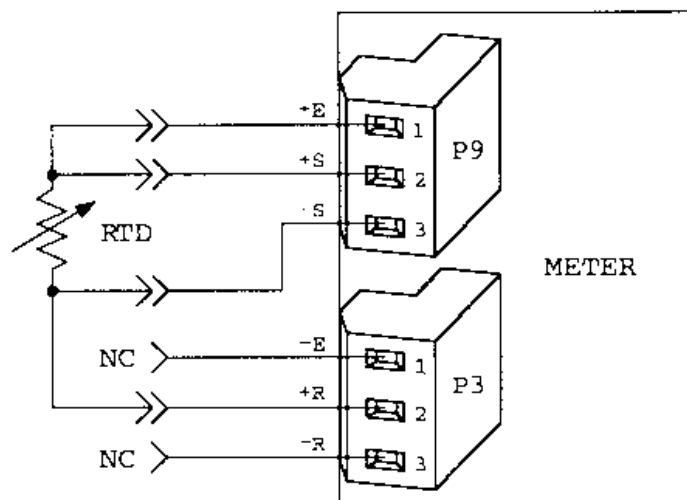

Figure 7-6. 4-Wire RTD

When lead resistance is compensated by 4-wire measurement, the reading rate is slightly lowered (this decrease is less than 20%).

160-MICROAMPERE CURRENT SOURCE

Each meter stores the calibration correction for its current source in its EEPROM. This factor is used to bring the readings produced by the actual current (somewhat less than 160 microamperes) up to the values that would be produced by precisely 160.0 microamperes. The meter, therefore, always enters the linearizing tables at the correct point.

For ohmmeter use, this calibration is less important, since no linearization is used and any scale-factor correction may be entered either with IN.SC.OF or RD.SC.OF controls. If both these scale factors are set to 1.0 with no offset, each ohm creates a display of "160" (the nominal current in microamperes), which may then be scaled as desired.

This low excitation current (using jumper S2P) value produces very low self-heating in the RTD element. This low current combined with the meter's low noise and high sensitivity to permit accurate measurement of RTDs or ohms from 0.6 to more than 6000 ohms on the high-input-impedance range (S2A and S2F jumpers).

If the ohms to be measured exceed 600 (up to 6000), the 1V range of your meter can be used (jumpers S2A and S2D); now the one-megohm input impedance of this range causes a very slight decrease in RTD sensitivity, which can be cancelled by the meter's input scaling and offset (IN.SC.OF).

1.6 MILLIAMPERE CURRENT SOURCE

Adding jumper S2V on the input board raises the current to 1.6 mA nominal, suitable for sensor resistances from less than one to 60 ohms. This current value, however, is not factory-calibrated, so that field calibration (using the meter's IN.SC.OF, INput SCaling and OFFset) is required by the following procedure (unless you have a linear input, in which case RD.SC.OF calibration is adequate):

To linearize correctly, it is necessary that the microvolts produced (displayed by the meter on its 100 mV range) by this high current

flowing in 10 ohms be adjusted to the same value as that of the calibrated low current flowing in 100 ohms.

To complete the data needed for automatic meter calibration, two additional microvolt readings are recorded at higher ohm values (for example, 30 ohms with high current and 300 ohms with low current, respectively).

When these four readings have been made on the 100 mV range and the meter switched back to RTD, the IN.SC.OF data are entered as:

INPUT1 = microvolts, 10 ohms, high current
READ 1 = microvolts, 100 ohms, low current
INPUT2 = microvolts, 30 ohms, high current
READ 2 = microvolts, 300 ohms, low current

This current-source calibration procedure places no limitation on the display scaling capability (RD.SC.OF), which is additionally available to handle conversion of the corrected input to any desired display units-of-measure.

Both current-source ranges have excellent load-voltage rejection, i.e., the current is virtually constant despite changes in the sensor voltage up to 1.5 volts across the load (well beyond the normal 100 mV full scale, or even the 1 V full scale).

7.7 10 Ω , 4-WIRE COPPER RTD INFORMATION

This section provides you with details on how to set up and use your meter with a 4-wire 10 Ω Copper RTD. Go through the following steps in order to have a correctly operating meter.

1. S1, S2, and S3 are factory configured. (Refer to Section 7.7.1).
2. Attach power wires to the power connector (orange) and attach to the rear of the meter. Refer to Section 7.7.3.
3. Power up the meter, observe readings and verify operation.

7

3- Wire RTD Setup Example

7.7.1 JUMPER INFORMATION FOR 10 Ω COPPER RTD

S1, S2, and S3 are factory configured as follows (refer to Figures 7-7 and 7-8):

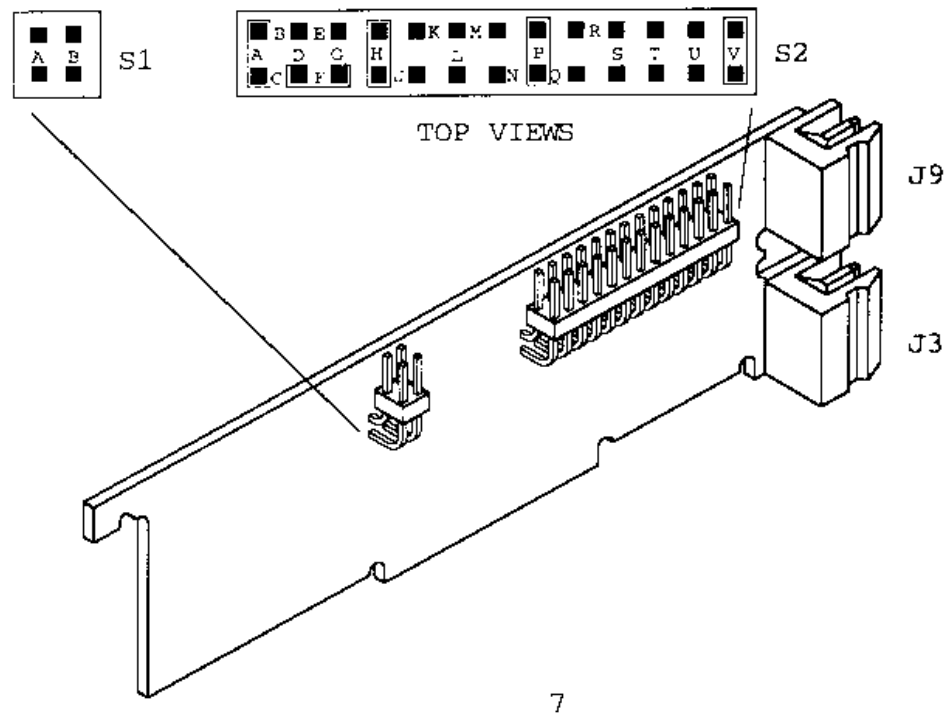

Figure 7-7. Signal Input Board Jumper Diagram with S1 and S2 Jumpers

JUMPER	BOARD	NOTES
no S1A no S1B S2A & S2F	Input Input Input	Slower (3/sec) read rate RTD, unipolar input -10 to 110 mV range (factory configuration)
S2H	Input	Brings lower lead voltage to meter
S2P	Input	Connect 160 μA current source
S2V	Input	Install if RTD is less than 60 ohms (1.6mA)

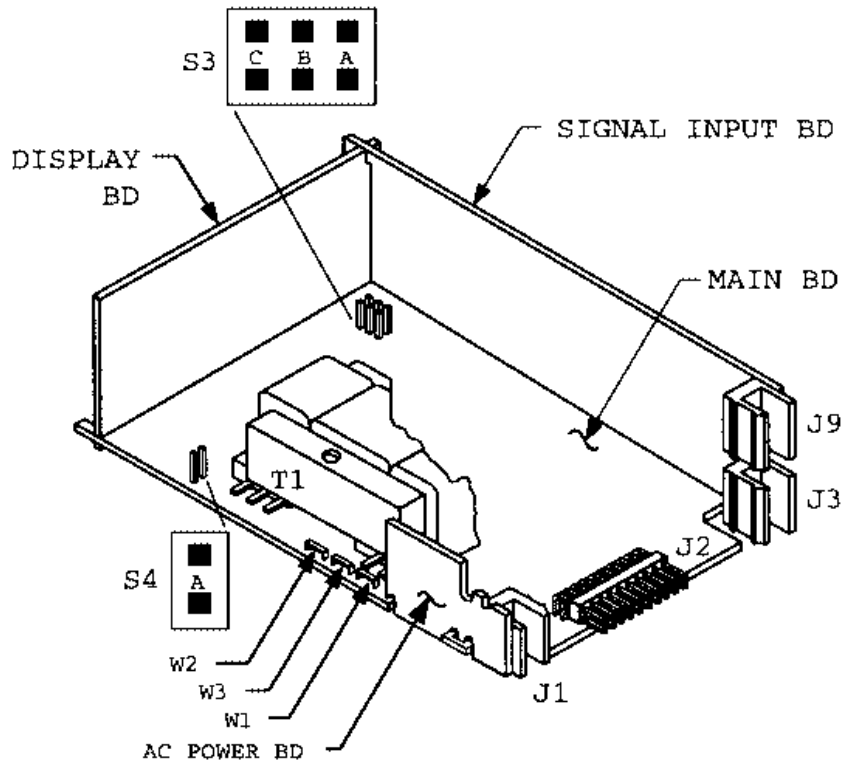

Figure 7-8. Main Board with S3 and S4 Jumpers

JUMPER	BOARD	NOTES
S3A	Main	Unlocks pushbutton programming
S3C	Main	Unlocks lockout menus
no S4A	Main	Not used for RTD inputs

7.7.2 INPUT CONNECTIONS

Figure 7-9 shows the input connections for 4-wire RTD.

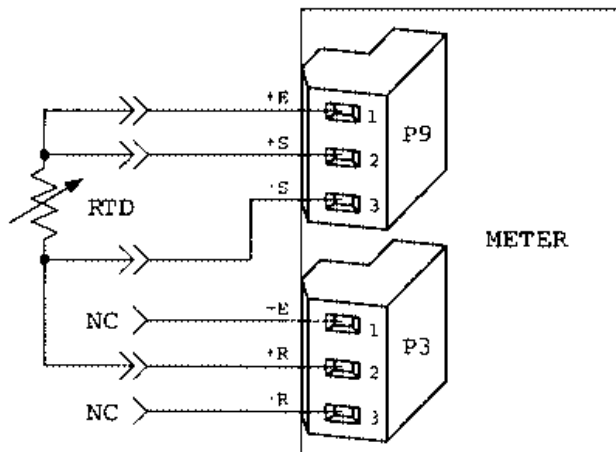

Figure 7-9. 4-Wire RTD

7

3- Wire RTD Setup Example

7.7.3 AC WIRING

Wire the meter following the AC wiring information listed below.

USA WIRING CODE	INTERN'L WIRING CODE	CONNECTION	PIN # ON ORANGE CONNECTOR
Black	Brown	AC High (HI)	1
White	Blue	AC Neutral(LO)	2
Green	Green/Yellow	AC Ground	3

1. Insert the P1 connector at the rear of the meter. Refer to Figure 7-10 for the location of P1.
2. Put the rear protective cover onto the rear of the meter.
3. Fasten down the rear protective cover with the cover mounting screw.

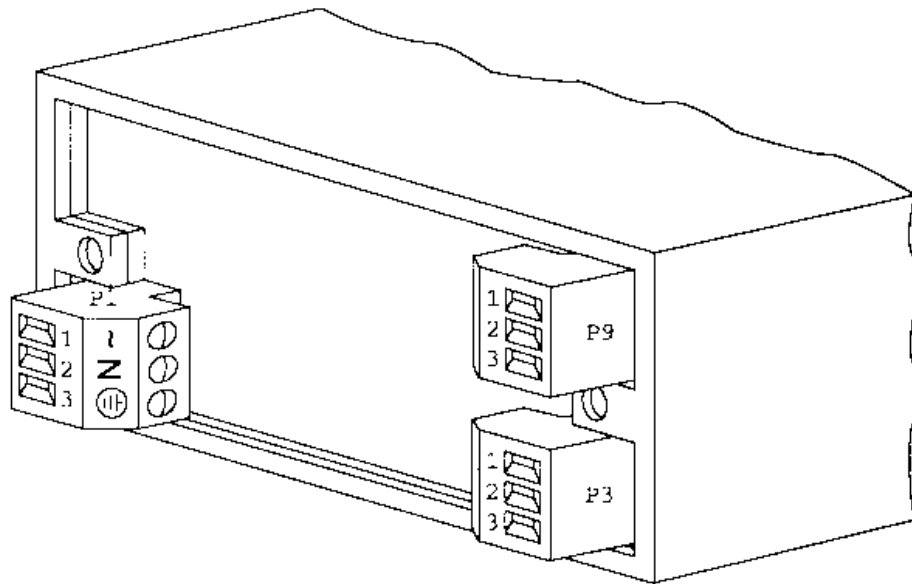

Figure 7-10. Rear View of the Meter

7.7.4 PROGRAMMING THE METER FOR THE CALIBRATION RUN

Make sure the meter is setup according to the 3 steps in Section 7.1.

PRESS	THEN PRESS (TO CHANGE IF REQUIRED)	UNTIL DISPLAY SHOWS	COMMENTS
'MENU'		"INPUT"	You need the display to show "INPUT".
'MIN'	'MAX'	"RTD"	Press the 'MIN' button to have the meter display (flashing) an input type. Press the 'MAX' button to select RTD.
'MENU'		"STORED" then "RTD"	Display will most often momentarily show "STORED" and then show "RTD".
<p>NOTE: In each and every case where the parameter is changed and then the 'MENU' button is pressed, the display will show "STORED". To simplify matters, "STORED" is not shown in the future but is understood.</p>			
'MIN'	'MAX'	"LINEAR"	Press the 'MIN' button to have choice the meter display show a signal type. Press the 'MAX' button to select "LINEAR" (copper is linear).
'MENU'		"RDG.CNF"	Set reading configuration.
'MIN'	'MAX'	"RDG.1=0"	Set "RDG.1=0" (Direct format) by pressing the 'MIN' button, and the display advances to "RDG.1". The 'MAX' button allows you to select "RDG.1=0". The 'MIN' and 'MAX' button descriptions are the same for subsequent steps.

continued next page

PRESS	THEN PRESS (TO CHANGE IF REQUIRED)	UNTIL DISPLAY SHOWS	COMMENTS
'MIN'	'MAX'	"RDG.2=0"	Make sure the display shows "RDG.2=0".
'MIN'	'MAX'	"RDG.3=0"	Make sure the display shows "RDG.3=0".
'MIN'	'MAX'	"RDG.4=1"	Make sure the display shows "RDG.4=1".
'MIN'	'MAX'	"RDG.5=1"	Make sure the display shows "RDG.5=1".
'MIN'	'MAX'	"RDG.6=1"	Make sure the display shows "RDG.6=1".
'MENU'		"RDG SC"	Stores RDG.CNF. Advance to "RDG SC".
'MIN'	'MAX'	"1.00000"	Unity gain for calibration run.
'MENU'		"RDG OF"	Stores RDG SC value. Advance to "RDG OF".
'MIN'	'MAX'	"000000"	No offset (decimal point can go anywhere).
'MENU'		"IN CNF"	Stores RDG OF value. Set Input Configurations.
'MIN'	'MAX'	"INP.1=0"	Make sure the display shows "INP.1=0".
'MIN'	'MAX'	"INP.2=0"	Make sure the display shows "INP.2=0".
'MIN'	'MAX'	"INP.3=0"	Make sure the display shows "INP.3=0".

continued next page

continued from previous page

PRESS	THEN PRESS (TO CHANGE IF REQUIRED)	UNTIL DISPLAY SHOWS	COMMENTS
'MIN'	'MAX'	"INP.4=0"	Make sure the display shows "INP.4=0".
'MIN'	'MAX'	"INP.5=1"	This RTD is 4-wire.
'MIN'	'MAX'	"INP.6=0"	Make sure the display shows "INP.6=0".
'MIN'	'MAX'	"INP.7=0"	Make sure the display shows "INP.7=0".
'MENU'		"IN.SC.OF"	Stores IN CNF values. Advance to "IN.SC.OF".
'MENU'		"DEC PT"	Advance to "DEC PT". Set the decimal point.
'MIN'	'MAX'	"FFFF.F"	Make sure the decimal point is in the 0.1 degree resolution.
'MENU'		"CNT BY"	Stores DEC PT location. Advance to "CNT BY".
'MIN'	'MAX'	"001"	Make sure the display shows "001".
'MENU'		"FIL.CNF"	Stores "CNT BY". Set Filter Configuration.
'MIN'	'MAX'	"FIL.1=0"	Make sure the display shows "FIL.1=0".
'MIN'	'MAX'	"FIL.2=1"	Make sure the display shows "FIL.2=1".

continued next page

continued from previous page

PRESS	THEN PRESS (TO CHANGE IF REQUIRED)	UNTIL DISPLAY SHOWS	COMMENTS
'MIN'	'MAX'	"FIL.3=0"	Set "FIL.3=0" for unfiltered Analog Output.
'MENU'		"FIL TI"	Stores FIL.CNF. Set Filter Time Constant.
'MIN'	'MAX'	"032"	Set to 032 for typical average number of samples.
'RESET', 'RESET'		Measured Values	Press the 'RESET' button two times. The display momentarily shows "RUN" and then the currently measured values.

7.7.5 TAKING THE INPUT CALIBRATION DATA

For 10 ohm copper RTD with alpha of 0.00386, the following data can be used.

INPUT1: $1600 (\mu\text{A}) \times 10.00 (\text{ohm}) = 16000$

READ 1: 25°C or 77°F

INPUT2: $1600 (\mu\text{A}) \times 15.217 (\text{ohm}) = 24347.2$

READ 2: 160°C or 320°F

For highest accuracy, calibrate the meter using Sections 7.7.5 and 7.7.6.

7.7.6 ENTERING THE CALIBRATION DATA IN INPUT SCALE AND OFFSET (EXAMPLE)

PRESS	THEN PRESS (TO CHANGE IF REQUIRED)	UNTIL DISPLAY SHOWS	COMMENTS
'MENU'		"INF CNF"	Set Input Configuration.
'MIN'	'MAX'	"INP.6=1"	By pressing the 'MIN' button 6 times, the meter advances to INP.6 (Input Scale and Offset). The 'MAX' button allows you to select "INP.6=1".
'MENU'		"IN.SC.OF"	Stores IN CNF. Advance to "IN.SC.OF".
'MIN'		"INPUT 1"	Put in first cal display reading.
'MIN'	'MAX'	"16000"	Reading from Appendix or from display.
'MENU'		"READ 1"	Enter corresponding temperature.
'MIN'	'MAX'	"00077.0"	Degrees from (77°F) calculations.
'MENU'		"INPUT2"	Put in upper point.
'MIN'	'MAX'	"24347.2"	Reading from Appendix or from display.

continued next page



3- Wire RTD Setup Example

continued from previous page

PRESS	THEN PRESS (TO CHANGE IF REQUIRED)	UNTIL DISPLAY SHOWS	COMMENTS
'MENU'		"READ 2"	Enter corresponding temperature.
'MIN'	'MAX'	"00320.0"	Degrees from Appendix or from calculations.
<p>DO NOT PREVIEW YOUR VALUES</p> <p>The INPUT values are entered in non-volatile memory and you cannot preview them. Every time you re-enter INPUT to preview the value, all zeroes will be displayed, though the value is in memory. If you press the 'MENU' button after seeing the zero values, the zero values will be entered into memory. Therefore, DO NOT TRY to preview your INPUT values.</p>			
'MENU'		"DEC PT"	Stores IN.SC.OF values. Advance to "DEC PT".
'RESET', 'RESET'		Measured Values	Press the 'RESET' button two times. Connect RTD and verify correct temperature reading. If that doesn't show, repeat this procedure.

7.7.7 10 Ω COPPER RTD CALIBRATION WITH HIGHEST ACCURACY

1. Replace the copper RTD with a carefully-measured resistor of approximately 10 ohms (or use a precision decade box). This resistance is "RO1".
2. Record the meter's displayed values as "INPUT1".
3. Read the 10 Ω copper RTD table from the RTD manufacturer or use one of three formulas for °F, °C, and Kelvin temperatures shown below for 10 Ω copper with an alpha of 0.00386 to obtain "RO1". This is "READ 1".

Condition formulas:

if "RDG.5=0" (for Celsius), use this formula:
 $READ\ 1 = 25 + 25.9 * (RO1 - 10)$

if "RDG.5=1" (for Fahrenheit), use this formula:
 $READ\ 1 = 77 + 46.61 * (RO1 - 10)$

if "RDG.5=2" (for Kelvin), use this formula:
 $READ\ 1 = [25 + 25.9 * (RO1 - 10)] + 273.2$

4. Replace the resistance with another carefully measured value close to 15 ohms; this is "RO2".
5. Record the meter's displayed value as "INPUT2".
6. Read the table or use one of the three formulas for °F, °C, or Kelvin temperatures shown below for 10 ohm copper with an alpha of 0.00386 to obtain "RO2". This is "READ 2".

Condition formulas:

if "RDG.5=0" (for Celsius), use this formula:
 $READ\ 2 = 25 + 25.9 * (RO2 - 10)$

if "RDG.5=1" (for Fahrenheit), use this formula:
 $READ\ 2 = 77 + 46.61 * (RO2 - 10)$

if "RDG.5=2" (for Kelvin), use this formula:
 $READ\ 2 = [25 + 25.9 * (RO2 - 10)] + 273.2$

7. Return to programming mode by pressing the 'MENU' button.

7.7.8 VERIFYING THE NUMBERS

1. Replace the high-ohm cal resistor with the lower-ohm value (10.12 ohm in the example).
2. If the display now reads "82.6F", the calibration is correct; if not, repeat the procedure in Section 7.7.7.
3. Replace the cal resistor with the actual RTD; the display value should closely agree with other temperature indicators in that vicinity.

7.7.9 TECHNICAL DISCUSSION

7.7.9.1 USE OF LINEAR SCALE FOR COPPER

Copper has an "alpha" (average temperature coefficient for the first 100 degrees) of 0.003860 per Kelvin (K), or 0.002145 per degree Fahrenheit (°F). This is identical to some platinum, but copper is more than 5 times closer to a straight line with temperature than platinum (much smaller dependence on the square of temperature). For the 500°F usual copper range, the maximum departure from the best straight line is approximately 0.5 degrees. Therefore, platinum uses a linearization routine and copper does not.

7.7.9.2 USE OF SLOWER READ RATE

Because most temperature measurements involve long time constants (large thermal masses), the slower read rate (3/sec) is recommended to reduce noise effects.

7.7.9.3 RTD OHMS AND METER CURRENT

The most sensitive meter range is used, which can accommodate, a copper resistance.

The resistance-detection current for these smaller-ohm RTDs is chosen to be ten times the normal 160 microamperes, for higher accuracy and less noise.

This excitation current, 1.6 mA nominal, flows from the meter's +E terminal, (P9-1), through the temperature-sensitive resistor (RTD), and back to the meter's -S terminal (P9-3).

The resistance of the two current-carrying leads is eliminated from the meter's measurement by using two more leads, from the top of the RTD to the meter's +S terminal (P9-2), and from the bottom of the RTD to the meter's +R terminal (P3-2).

If the RTD is not provided with four wires for your lead connections, connect the +S lead as close as possible to the top of the RTD and the +R lead as close as possible to the bottom of the RTD.

7.7.9.4 2-WIRE HOOKUP

It is possible that your leads to and from the RTD are of negligible resistance (for example, short and heavy-gauge wires), and that you are satisfied with the accuracy of a 2-wire hookup.

In this case:

1. Program your meter exactly as for a plain linear input.
2. Move jumper S2H to S2M on the signal input board.
3. Jumper the +E (P9-1) and +S pins (P9-2), on the connector at the rear of the meter.
4. Do not attach any lead to +R (P3-2).

7.7.9.5 3-WIRE HOOKUP

If you have a 3-wire RTD, it is recommended that you use leads of equal resistance (equal lengths of the same gauge) to get full advantage of the meter's line-drop-cancellation capability.

In this case, the hookup is the same as for 4-wire except that the lead from the top of the RTD to +S (P9-2) is replaced by a jumper on the connector from +E, (P9-1) to +S (P9-2).

In this 3-wire case, there is just one programming change: set "INP.5=0"; this invokes the meter's 3-wire lead-drop cancellation computation rather than that for 4 wires.

This page is intentionally left blank

8. Transmitter Hookup Example with RTD

8.1 JUMPER INFORMATION

S1, S2 and S3 are factory configured as follows (refer to Figures 8-1 and 8-2):

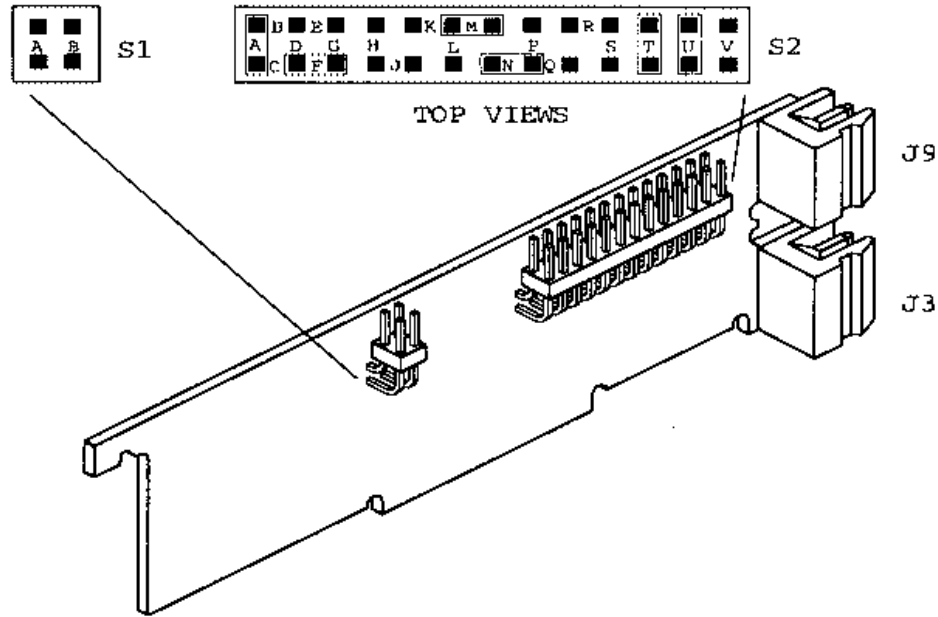

Figure 8-1. Signal Input Board Jumper Diagram with S1 and S2 Jumpers

JUMPER	BOARD	NOTES
no S1A	Input	Slow (3/sec) read rate
no S1B	Input	Unipolar input range
S2A, S2F & S2U	Input	20 mA input range
S2M	Input	2-wire measurement
S2N & S2T	Input	Bring out meter excitation

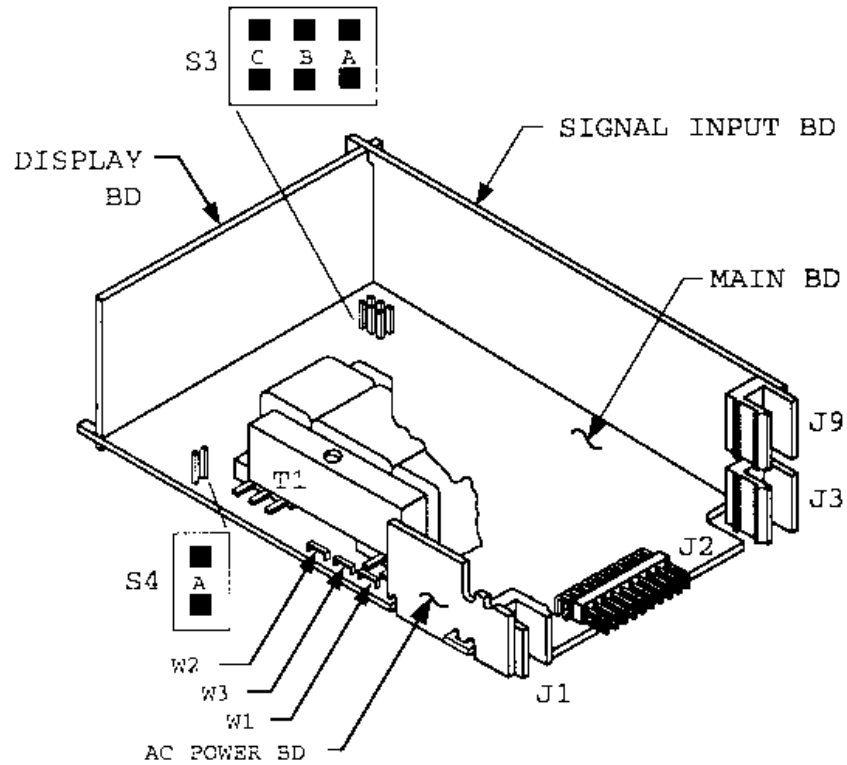

Figure 8-2. Main Board with S3 and S4 Jumpers

JUMPER	BOARD	NOTES
S3A	Main	Unlocks pushbutton programming
no S3B	Main	Meter calibration locked out
S3C	Main	Unlocks the lockout menus
no S4A	Main	24 V is recommended; if installed, you get 10 V excitation

8.2 TRANSMITTER INPUT CONNECTIONS

Refer to Figure 8-3 for the wiring diagram for 2-wire RTD current-loop transmitter hookup. Figure 8-4 shows 4-wire RTD transmitter hookup.

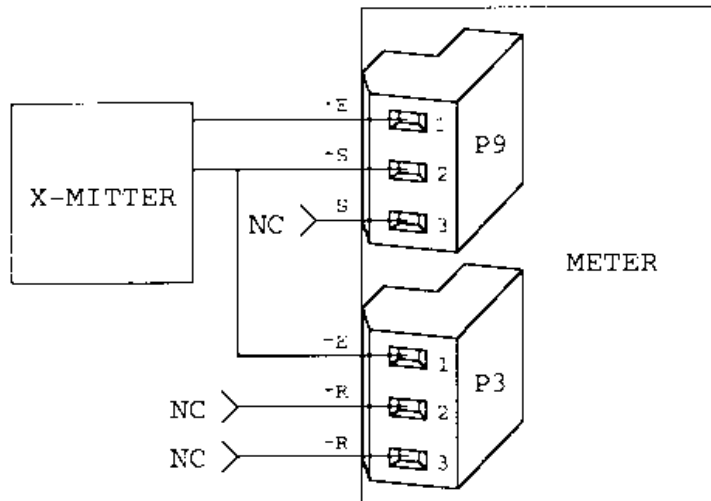

Figure 8-3. 2-Wire RTD Current-Loop Transmitter Hookup

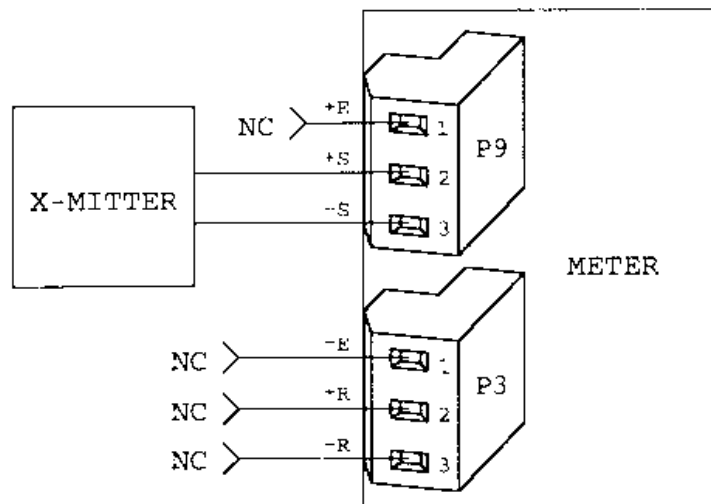

Figure 8-4. 4-Wire RTD Transmitter Hookup

8.3 WIRING WITH TRANSMITTER

8.3.1 FOR RTDS

The RTD is excited by and provides the signal for a current-loop transmitter, which in turn is powered by and feeds the current signal to the meter. To convert this current to the basic input range (0-100mV), install a jumper in the S2U position on the signal input board, which will convert this current to a voltage by an internal 5 Ω resistor.

The input attenuator is blocked out by installing S2A and S2F on the signal input board.

With a transmitter input, if the current-loop is accidentally opened, the meter will read zero since the current-shunt resistor is across the input; therefore no open-lead jumper (S2R or S2S) is used.

When a transmitter requires excitation, install jumpers S2N and S2T on the signal input board to bring out the 24 V excitation to drive the transmitter's current loop.

The current for the RTD in this case is furnished by the transmitter, which in turn is driven by the meter's power loop. The meter's internal scaling will be used to remove transmitter zero, span, and current error.

It is, of course, possible to use the meter as a current receiver from a transmitter which has its own power ("4-wire" transmitter). In this case, no connection is made to P9-1, the positive (+) E terminal. The current from the transmitter's positive (+) terminal is now put in the meter's positive (+) S pin (P9-2) and the negative (-) S pin (P9-3) connected to the transmitter's negative (-) terminal.

For "2-wire" transmitters, the meter's positive (+) E terminal (P9-1) now supplies the voltage to the transmitter's positive loop terminal, and the transmitter's negative loop terminal is brought back to the meter's positive (+) S signal input terminal (P9-2). To complete the loop, the input connector's negative (-) E terminal (P9-1) is jumpered to ground (P9-3), same potential as negative (-) S on (P9-3).

S2H is not used for either transmitter or 2-wire RTD input, but in both cases this auxiliary input is tied to ground by inserting S2M.

8.3.2 FOR THERMOCOUPLES

The thermocouple's millivolt output is converted to a 4-20mA signal similar to the RTD.

8.4 TC/RTD TRANSMITTER CALIBRATION

The following information must be carefully adhered to (Do not leave out any steps).

PRESS	THEN PRESS (TO CHANGE IF REQUIRED)	UNTIL DISPLAY SHOWS	COMMENTS
'MENU'		"INPUT"	You need the display to show "INPUT".
'MIN'	'MAX'	"RTD"	Press the 'MIN' button to have meter display (flashing) an input type. Press the 'MAX' button to select RTD.
'MENU'		"STORED" then "RTD"	The display will then most often momentarily show "STORED" and then show "RTD".
NOTE: In each and every case where the parameter is changed and then the 'MENU' button is pressed, the display will show "STORED". To simplify matters, "STORED" is not shown in the future but is understood.			
'MIN'	'MAX'	"LINEAR"	Press the 'MIN' button to have the display show a signal type. Press the 'MAX' button to select LINEAR.
'MENU'		"RDG.CNF"	Set reading configuration.

continued next page

PRESS	THEN PRESS (TO CHANGE IF REQUIRED)	UNTIL DISPLAY SHOWS	COMMENTS
'MIN'	'MAX'	"RDG.1=0"	Set "RDG.1=0" (Direct format) By pressing the 'MIN' button, the meter advances to RDG.1. The 'MAX' button allows you to select "RDG.1=0". The 'MIN' and 'MAX' button descriptions are the same for subsequent steps.
'MIN'	'MAX'	"RDG.2=0"	Make sure the display shows "RDG.2=0".
'MIN'	'MAX'	"RDG.3=0"	Make sure the display shows "RDG.3=0".
'MIN'	'MAX'	"RDG.4=1"	Make sure the display shows "RDG.4=1".
'MIN'	'MAX'	"RDG.5=2"	Make sure the display shows "RDG.5=2".
'MIN'	'MAX'	"RDG.6=0"	Make sure the display shows "RDG.6=0".
'MENU'		"RDG SC"	Stores "RDG.CNF". Advance to "RDG SC".
'MIN'	'MAX'	"1.00000"	Unity gain for calibration run.
'MENU'		"RDG OF"	Stores "RDG SC". Advance to "RDG OF".
'MIN'	'MAX'	"00000.0"	No offset (decimal point can go anywhere).

continued next page

continued from previous page

PRESS	THEN PRESS (TO CHANGE IF REQUIRED)	UNTIL DISPLAY SHOWS	COMMENTS
'MENU'		"IN CNF"	Stores "RDG OF". Set Input Configurations.
'MIN'	'MAX'	"INP.1=0"	Make sure the display shows "INP.1=0".
'MIN'	'MAX'	"INP.2=0"	Make sure the display shows "INP.2=0".
'MIN'	'MAX'	"INP.3=0"	Make sure the display shows "INP.3=0".
'MIN'	'MAX'	"INP.4=2"	Make sure the display shows "INP.4=2".
'MIN'	'MAX'	"INP.5=0"	Make sure the display shows "INP.5=0".
'MIN'	'MAX'	"INP.6=0"	Make sure the display shows "INP.6=0".
'MIN'	'MAX'	"INP.7=0"	Make sure the display shows "INP.7=0".
'MENU'		"IN.SC.OF"	Stores IN CNF. Advance to "IN.SC.OF".
'MENU'		"DEC PT"	Advance to "DEC PT". Set the decimal point.
'MIN'	'MAX'	"FFFFFF."	Make sure the decimal point is in the 1 degree resolution.
'MENU'		"CNT BY"	Stores "DEC PT". location. Advance to "CNT BY".

continued next page

continued from previous page

PRESS	THEN PRESS (TO CHANGE IF REQUIRED)	UNTIL DISPLAY SHOWS	COMMENTS
'MIN'	'MAX'	"001"	Make sure the display shows "001".
'MENU'		"FIL.CNF"	Stores "CNT BY" value. Set Filter Configuration.
'MIN'	'MAX'	"FIL.1=0"	Make sure the display shows "FIL.1=0".
'MIN'	'MAX'	"FIL.2=1"	Make sure the display shows "FIL.2=1".
'MIN'	'MAX'	"FIL.3=0"	Set "FIL.3=0" for unfiltered Analog Output.
'MENU'		"FIL TI"	Stores "FIL CNF". Set Filter Time Constant.
'MIN'	'MAX'	"128"	Set to 128.
'MENU'		"STORED" then "SP.CNF"	Press the 'MENU' button to store your "FIL TI" selection. The display will momentarily show "STORED" and then will display "SP.CNF"
'RESET', SET'		Measured Values	Press the 'RESET' 'RE-button two times. The display will momentarily show "RUN" and then the currently-measured values.

8.5 RECORDING THE CALIBRATION VALUES FOR RTD

8.5.1 SETTING THE LOWER OF THE TWO INPUTS

NOTE: You must complete this section before continuing on.

Replace the temperature sensor with a precision decade box for RTDs or calibrators for Thermocouples with the bottom value of

the desired range of operation. Refer to the appropriate Section 21 in the rear of this manual for the resistance value.

Record resistor value here: _____

If the transmitter output is exactly 4mA, the display will read 20,000 μV ($4000 \mu\text{A} \times 5 \text{ ohms}$). If the display is significantly different from 20,000 μV (the meter is not outputting 4 mA), the transmitter zero may be suppressed too heavily and the current loop is below the minimum current for accurate operation. Adjust the transmitter as needed.

This first meter reading should be recorded as "INPUT1" for use in IN.SC.OF.

Record "INPUT1" value here: _____

Multiply above noted resistor value by 160.000 (microamperes): the resulting microvolt value is "READ1".

Record "READ1" value here: _____

8.5.2 SETTING THE UPPER OF THE TWO INPUTS

Adjust the decade box with the value of the top of the desired range. Refer to the appropriate Appendix in the rear of this manual for the resistance value.

Record the resistor value here: _____

If the transmitter output is exactly 20mA, the display will read 100,000 μV ($20,000 \mu\text{A} \times 5 \text{ ohms}$). The display is not supposed to exceed 110,000 μV . If the display is above 110,000 μV , the span may be too high and the loop current forced to an inaccurate high value. Adjust the transmitter as needed.

This second meter reading should be recorded as "INPUT2".

Record "INPUT2" value here: _____

Multiply the resistance by 160.000 (microamperes) to calculate "READ2".

Record "READ2" value here: _____.

Now that you have the data for "IN.SC.OF", proceed as follows:

PRESS	THEN PRESS (TO CHANGE IF REQUIRED)	UNTIL DISPLAY SHOWS	COMMENTS
'MENU'		"INPUT"	You need the display to show "INPUT".
MAKE SURE THE PROPER SENSOR (RTD OR THERMO-COUPLE) IS ATTACHED TO THE TRANSMITTER.			
'MIN'	'MAX'	"RTD"	Press the 'MIN' button to have meter display (flashing) an input type. Press the 'MAX' button to select RTD.
'MENU'		"STORED" then "RTD"	The display will most often momentarily show "STORED" and then show "RTD".
NOTE: In each and every case where the parameter is changed and then the 'MENU' button is pressed, the display will show "STORED". To simplify matters, "STORED" is not shown in the future but is understood.			
'MIN'	'MAX'	"2PT385"	Press the 'MIN' button to have the meter display a signal type. Press the 'MAX' button to select 2PT385.
OR			
'MIN'	'MAX'	"TC"	Press the 'MIN' button to have meter display (flashing) an input type. Press the 'MAX' button to select "TC".

continued next page

continued from previous page

PRESS	THEN PRESS (TO CHANGE IF REQUIRED)	UNTIL DISPLAY SHOWS	COMMENTS
'MENU'		"STORED" then "TC"	The display will most often momentarily show "STORED" and then show "TC".
'MIN'	'MAX'	"K"	Press the 'MIN' button to have the meter display a signal type. Press the 'MAX' button to select Type K.
'MENU'		"RDG.CNF"	Stores signal type. Set reading configuration.
'MIN'	'MAX'	"RDG.5=1"	Make sure the display shows "RDG.5=1".
'MIN'	'MAX'	"RDG.6=1"	Make sure the display shows "RDG.6=1".
'MENU'		"RDG SC"	Stores "RDG.CNF". Advance to "RDG SC".
'MENU'		"RDG OF"	Bypass "RDG SC" Advance to "RDG OF".
'MENU'		"IN CNF"	Bypass "RDG OF". Set Input Configurations.
'MIN'	'MAX'	"INP.2=0"	Make sure the display shows "INP.2=0".
'MIN'	'MAX'	"INP.6=1"	Make sure the display shows "INP.6=1".
'MENU'		"IN.SC.OF"	Stores "INP CNF". Advance to "IN.SC.OF".

continued next page

continued from previous page

PRESS	THEN PRESS (TO CHANGE IF REQUIRED)	UNTIL DISPLAY SHOWS	COMMENTS
'MIN'		"INPUT1"	Allows you to put in calculated data into the meter.
'MIN'	'MAX'	"uuuuuu"	Insert INPUT1 value here.
'MIN'		"READ 1"	Allows you to put in calculated data into the meter.
'MIN'	'MAX'	"xxxxxx"	Insert READ1 value here.
'MIN'		"INPUT2"	Allows you to put in calculated data into the meter.
'MIN'	'MAX'	"vvvvvv"	Insert INPUT2 value here.
'MIN'		"READ 2"	Allows you to put in calculated data into the meter.
'MIN'	'MAX'	"yyyyyy"	Insert "READ 2" value here.
'MENU'		"DEC PT"	Stores "IN.SC.OF". Advance to "DEC PT".
'MIN'	'MAX'	"FFFF.FF"	Make sure the decimal point is in the 0.01° resolution.
'MENU'		"CNT BY"	Stores the decimal point location. Advance to "CNT BY".

continued next page

continued from previous page

PRESS	THEN PRESS (TO CHANGE IF REQUIRED)	UNTIL DISPLAY SHOWS	COMMENTS
'MENU'		"FIL.CNF"	Bypass "CNT BY". Advance to "FIL TI".
'MENU'		"FIL TI"	Bypass "FIL.CNF".
'RESET', 'RESET'		Measured Values	Press the 'RESET' button two times. The display momentarily shows "RUN" and then the currently measured values.

For a detailed explanation of each menu item (for example, "INPUT", "RDG.CNF", etc.), refer to Section 9.

This page is intentionally left blank

9. Detailed Explanation of Lockout Configurations and Meter Function Menus

HOW TO USE THE TABLES IN SECTION 9

MIN/MAX/MENU BUTTONS	These are the buttons on the meter you are to press to access the parameters given in the same column.
MAIN MENU/SUBMENU:	These are headings for the table columns.
DISPLAYED INFORMATION:	These are parameters seen on the display after pressing either 'MIN', 'MAX', or 'MENU' button(s).

NOTE: If you press the 'RESET' button two times while the meter is in the run mode, all Setpoints, Alarms, Peak & Valley will be reset and the meter will begin new measurements.

If you press the 'RESET' button one time while in the configuration mode, you will move one MAIN MENU backwards and any selection will not be saved. If you press the 'RESET' button two times while in the configuration mode, you will reset the meter and only those menu items saved by pressing the 'MENU' button will be saved.

9.1 INDIVIDUAL LOCKOUT INFORMATION

To restrict access to different parameters of the program in the meter, you may want to lockout parts of the meter. When you lock out a parameter, it will no longer appear when you scroll through the menu. To lock out specific parameters of the meter (setpoint, scaling), refer to the following tables.

Once set (to unlock useful features for a given application and to lock out any features), these four "L1C", "L2C", "L3C", and "L4C" can be rapidly skipped over by pressing the 'MENU' button four times.

MENU BUTTON MAIN MENU	MIN/MAX* BUTTON SUB MENU	CONDITION
"L1 CNF":		LOCKOUT CONFIGURATION #1
	" <u>L1C.1=0</u> "	Setpoint 1 change unlocked.
	"L1C.1=1"	Setpoint 1 change locked out.
	" <u>L1C.2=0</u> "	Setpoint 2 change unlocked.
	"L1C.2=1"	Setpoint 2 change locked out.
	" <u>L1C.3=0</u> "	Setpoint 3 (Alarm 1) change unlocked.
	"L1C.3=1"	Setpoint 3 (Alarm 1) change locked out.
	" <u>L1C.4=0</u> "	Setpoint #4 (Alarm 2) change unlocked.
	"L1C.4=1"	Setpoint #4 (Alarm 2) change locked out.
	" <u>L1C.5=0</u> "	Valley-value (LO RDG) display is permitted.
	"L1C.5=1"	Valley-value (LO RDG) display is not permitted.
	" <u>L1C.6=0</u> "	Peak-value (HI RDG) display is permitted.
	"L1C.6=1"	Peak-value (HI RDG) display is not permitted.
	" <u>L1C.7=0</u> "	INPUT CLASS (TC or RTD) can be selected.
	"L1C.7=1"	INPUT CLASS (TC or RTD) - INPUT CLASS is locked out.
	" <u>L1C.8=0</u> "	INPUT TYPE (J, K, E, T, N, R, S, B, DIN J or 2-, 3-, 4-wire RTD) can be selected.
"L1C.8=1"	INPUT TYPE (J, K, E, T, N, R, S, B, DIN J or 2-, 3-, 4-wire RTD) - INPUT TYPE is locked out.	

* The 'MIN' button allows you to sequence through LIC.1, LIC.2, LIC.3, LIC.4, LIC.5, LIC.6, LIC.7 and LIC.8.

The 'MAX' button allows you to select the "0" or "1" state for each "LIC" condition.

The 'MENU' button stores the selected values for all "LIC" condition(s) changed and advances the meter to "L2 CNF". Do not press the 'MENU' button after each change within the submenu or the meter will advance to the next menu item.

Every underlined "0" or "1" state is the factory preset value.

MENU BUTTON MAIN MENU	MIN/MAX* BUTTON SUB MENU	DESCRIPTION
"L2 CNF":	<u>"L2C.1=0"</u>	LOCKOUT CONFIGURATION #2
	"L2C.1=1"	RDG.CNF (scale/offset method and display features) may be chosen. RDG.CNF (scale/offset method and display features) is locked out.
	<u>"L2C.2=0"</u>	Either RDG SC (computed input-to-display scale factor) or RD.SC.OF (two data points, which determine the reading scale/offset) may be entered.
	"L2C.2=1"	Either RDG SC (computed input-to-display scale factor) or RD.SC.OF (two data points, which determine the reading scale/offset) is locked out.

MENU BUTTON MAIN MENU	MIN/MAX* BUTTON SUB MENU	CONDITION
	" <u>L2C.3</u> =0"	RDG OF (offset computed in display digits) may be entered.
	"L2C.3=1"	RDG OF (offset computed in display digits) is locked out.
	" <u>L2C.4</u> =0"	INP.CNF (meter rates, front-end features, prelinearizing scale/offset) may be chosen.
	"L2C.4=1"	INP.CNF (meter rates, front-end features, prelinearizing scale/offset) may not be locked out.
	" <u>L2C.5</u> =0"	IN.SC.OF (two data points for additional scale/offset) may be entered.
	"L2C.5=1"	IN.SC.OF (two data points for additional scale/offset) may not be entered.
	" <u>L2C.6</u> =0"	DEC PT (decimal-point location) may be chosen
	"L2C.6=1"	DEC PT (decimal-point location) may not be chosen.
	" <u>L2C.7</u> =0"	CNT BY (round off of display) can be specified.
	"L2C.7=1"	CNT BY (round off of display) cannot be specified.
	" <u>L2C.8</u> =0"	FIL CNF (adaptive/fixed filtering and for which output(s)) can be chosen.
	"L2C.8=1"	FIL CNF (adaptive/fixed filtering and for which output(s)) cannot be chosen.

* The 'MIN' button allows you to sequence through L2C.1, L2C.2, L2C.3, L2C.4, L2C.5, L2C.6, L2C.7, and L2C.8.

The 'MAX' button allows you to select the "0" or "1" state for each "L2C" condition.

The 'MENU' button stores the selected values for all "L2C" condition(s) changed and advances the meter to "L3 CNF". Do not press the 'MENU' button after each change within the submenu or the meter will advance to the next menu item.

Every underlined "0" or "1" state is the factory preset value.

MENU BUTTON MAIN MENU	MIN/MAX* BUTTON SUB MENU	CONDITION
"L3 CNF":		LOCKOUT CONFIGURATION#3
	" <u>L3C.1</u> =0"	FIL TI (# of samples in average) can be chosen.
	"L3C.1=1"	FIL TI (# of samples in average) cannot be locked out.
	" <u>L3C.2</u> =0"	SP CNF (mode of action of setpoints 1 & 2 LEDs, transistors and relays) can be selected.
	"L3C.2=1"	SP CNF (mode of action of setpoints 1 & 2 LEDs, transistors and relays) cannot be locked out.
	" <u>L3C.3</u> =0"	AL CNF (mode of action of Setpoints 3 & 4, often used as alarms) can be locked out.
	"L3C.3=1"	AL CNF (mode of action of setpoints 3 & 4, often used as alarms) cannot be locked out.
" <u>L3C.4</u> =0"	AL FNC (Setpoints 3 & 4 independent or ganged with Setpoints 1 and 2) can be selected.	

continued next page

continued from previous page

MENU BUTTON MAIN MENU	MIN/MAX* BUTTON SUB MENU	CONDITION
	"L3C.4=1"	AL FNC (Setpoints 3 & 4 independent or ganged with Setpoints 1 and 2) cannot be accessed.
	" <u>L3C.5=0</u> "	AL RDG (# of out-of-range readings before trip of setpoints 3 & 4) can be selected.
	"L3C.5=1"	AL RDG (# of out-of-range readings before trip of setpoints 3 & 4) cannot be accessed.
	" <u>L3C.6=0</u> "	SP DB (hysteresis or deadband of Setpoints and Alarms) can be specified.
	"L3C.6=1"	SP DB (hysteresis (deadband) of Setpoints and Alarms) cannot be accessed.
	" <u>L3C.7=0</u> "	OUT.CNF (analog & BCD outputs, setpoint display flashing) can be specified.
	"L3C.7=1"	OUT.CNF (analog & BCD outputs, setpoint display flashing) cannot be accessed.
	" <u>L3C.8=0</u> "	OT.SC.OF (2-data-point method for independent analog-output scale/offset) can be entered.
	"L3C.8=1"	OT.SC.OF (2-data-point method for independent analog-output scale/offset) cannot be accessed.

* The 'MIN' button allows you to sequence through L3C.1, L3C.2, L3C.3, L3C.4, L3C.5, L3C.6, L3C.7, and L3C.8.

The 'MAX' button allows you to select the "0" or "1" state for each "L3C" condition.

The 'MENU' button stores the selected values for all "L3C" condition(s) changed and advances the meter to "L4 CNF". Do not press the 'MENU' button after each change within the submenu or the meter will advance to the next menu item.

Every underlined "0" or "1" state is the factory preset value.

MENU BUTTON MAIN MENU	MIN/MAX* BUTTON SUB MENU	DESCRIPTION
"L4 CNF":		LOCKOUT CONFIGURATION #4
	" <u>L4C.1</u> =0"	BAUD (communication rate) can be chosen.
	"L4C.1=1"	BAUD (communication rate) cannot be accessed.
	" <u>L4C.2</u> =0"	SER.CNF (parity/stop-bit length) is selectable.
	"L4C.2=1"	SER.CNF (parity/stop-bit length) is not selectable.
	" <u>L4C.3</u> =0"	ADDRES (meter address # on a multipoint bus) can be changed.
	"L4C.3=1"	ADDRES (meter address # on a multipoint bus) cannot be accessed.
	" <u>L4C.4</u> =0"	DAT FT & BUS FT (format of data stream and bus interaction for digital communications) can be altered.
"L4C.4=1"	DAT FT & BUS FT (format of data stream and bus interaction for digital communications) cannot be accessed.	

continued next page

continued from previous page

MENU BUTTON MAIN MENU	MIN/MAX* BUTTON SUB MENU	DESCRIPTION
	<u>"L4C.5=0"</u>	SERCNT (interval # of readings for the automatic digital output of meter) can be changed.
	"L4C.5=1"	SERCNT (interval # of readings for the automatic digital output of meter) cannot be accessed.
	<u>"L4C.6=0"</u>	Analog output trim input can be entered.
	"L4C.6=1"	Analog output trim input cannot be entered.
	<u>"L4C.7=0"</u>	Unlocked C.JUN.OF:
	"L4C.7=1"	Cold-junction offset (for TC input only)

* The 'MIN' button allows you to sequence through L4C.1, L4C.2, L4C.3, L4C.4, L4C.5, L4C.6 and L4C.7.

The 'MAX' button allows you to select the "0" or "1" state for each "L4C" condition.

The 'MENU' button stores the selected values for all "L4C" condition(s) changed and advances the meter to "INPUT". Do not press the 'MENU' button after each change within the submenu or the meter will advance to the next menu item.

Every underlined "0" or "1" state is the factory preset value.

9.2 METER FUNCTION MENUS

NOTE: Sections 9.2.1 through 9.2.23 are also shown in the Quick Reference Guide.

9.2.1 INPUT

By pressing the 'MAX' and 'MENU' buttons you can select and then store respectively either "TC" or "RTD" (input type). Refer to the chart below to go the next level of programming of the meter.

MAX/MENU BUTTON MAIN MENU	MAX/MENU * BUTTON SUB MENU	DESCRIPTION
"TC":	"J" "K" "T" "E" "N" "DNJ" "R" "S" "B"	SIGNAL TYPE J Thermocouple K Thermocouple T Thermocouple E Thermocouple N Thermocouple J DIN Thermocouple R Thermocouple S Thermocouple B Thermocouple
"RTD"	"2PT392" "3PT392" "4PT392" "2PT385" <u>"3PT385"</u> "4PT385" "LINEAR"	2-wire 100 Ω platinum NIST RTD, (alpha = 00.00392) 3-wire 100 Ω platinum NIST RTD, (alpha = 00.00392) 4-wire 100 Ω platinum NIST RTD, (alpha = 00.00392) 2-wire 100 Ω platinum DIN RTD, (alpha = 00.00385) 3-wire 100 Ω platinum DIN RTD, (alpha = 00.00385) 4-wire 100 Ω platinum DIN RTD, (alpha = 00.00385) Any linear RTD such as 10 Ω copper

* After pressing the 'MAX' button, press the 'MENU' button to store the selection and the meter will then display "RDG.CNF".

Every underlined item is the factory preset setting.

9.2.2 RDG.CNF (READING CONFIGURATION)

Reading configuration is used to select:

- reading scale and offset (direct vs 2-point) [RDG.1]
- active or independent decimal point [RDG.2]
- display brightness [RDG.3]
- leading zero suppression on your meter display [RDG.4]
- units of measure (F, C or K) [RDG.5]
- display of units of measure (F, C or K) on the meter display [RDG.6]

Direct scale and Offset: these two values are used in the straight line equation, $y = mx + b$.

Display = m times input plus b or [m (input) + b] (where m is the RDG SC and b is the RDG OF).

The 2-data-point method allows the user to use two known points to convert from one scale to another. For example, to convert from degrees Fahrenheit to degrees Rankine, enter two (2) known points, such as $-459.67^{\circ}\text{F} = 0^{\circ}\text{R}$ and $0^{\circ}\text{F} = 459.67^{\circ}\text{R}$. The meter will automatically compute scale and offset and display the correct value.

MENU BUTTON MAIN MENU	MIN/MAX/ MENU * BUTTON SUB MENU	DESCRIPTION
"RDG.CNF":		READING CONFIGURATION
	"RDG.1=0"	Reading Scale & Offset: Direct Format
	<u>"RDG.1=1"</u>	2-Coordinate format
	"RDG.2=0"	Decimal point effect: Active
	<u>"RDG.2=1"</u>	Not used for temperature
	"RDG.3=0"	Display Brightness: Normal
	<u>"RDG.3=1"</u>	50% of Normal
	"RDG.4=0"	Leading Zeros on Display: Displayed
	<u>"RDG.4=1"</u>	Not Displayed
	"RDG.5=0"	Unit of Temperature: C: Celsius
	<u>"RDG.5=1"</u>	F: Fahrenheit
	"RDG.5=2"	K: Kelvin
"RDG.6=0"	Temp. Unit on Display: Not Displayed	
<u>"RDG.6=1"</u>	Displayed	

continued next page

continued from previous page

MENU BUTTON MAIN MENU	MIN/MAX/ MENU * BUTTON SUB MENU	DESCRIPTION
	<u>"RDG.7=0"</u> "RDG.7=1"	Resetting Mode: Grounding P2-5 causes Hard Reset (RESET 2) Grounding P2-5 causes Peak/Valley (HI/LO) Reset

* The 'MIN' button allows you to sequence through RDG.1, RDG.2, RDG.3, RDG.4, RDG.5, RDG.6, and RDG.7.

The 'MAX' button allows you to select the "0" or "1" state for each "RDG" condition.

The 'MENU' button stores the selected values for all "RDG.CNF" condition(s) changed and advances the meter to "RD SC". Do not press the 'MENU' button after each change within the submenu or the meter will advance to the next menu item.

Every underlined "0" or "1" state is the factory preset value.

9.2.3 RDG SC (READING SCALE) AND RDG OF (READING OFFSET)

Typically, this would not be used if the thermocouple input or 100 ohm platinum RTD input is chosen, since there is a linearization procedure which tracks the entire NIST tables. This would only be used if you are connecting a 10 ohm copper RTD input or platinum RTD other than 100 ohm, or for ohms scaling.

If "RDG.1=0" were chosen, then you go automatically into "RDG SC" and "RDG OF" where:

"RDG SC" is reading scale from -99999 to +499999 where you set the display to "1.00000" and "RDG OF" is reading offset from -99999 to 999999 when you set the display to "000000".

When "RDG SC" is displayed, press the 'MIN' button to see the previously-set value. For temperature measurement, scale is set to "1.00000" using the 'MIN/MAX' buttons since the scale was selected previously to F, C or K by "RDG.5". Store by pressing the 'MENU' button.

For "RDG OF", you may choose to enter a reference temperature offset here (e.g., "-100.00") so that the display will read deviation of the input from the boiling point (or some other temperature).

If "RDG.1 = 1" were chosen, then you go automatically into "RD.SC.OF".

MENU BUTTON MAIN MENU	MIN/MAX* BUTTON SUB MENU 1	MIN/MAX /MENU** BUTTON SUB MENU 2	DESCRIPTION
"RD.SC.OF":	INPUT 1	000000. ("00000.0")	READING SCALE & OFFSET Item #1 of Coordinate #1. Enter the first value displayed by the meter.
		000000. ("00000.0")	Item #2 of Coordinate #1. Enter first desired value.
	INPUT 2	000000. ("10000.0")	Item #1 of Coordinate #2. Enter the second value displayed by the meter.
		000000. ("10000.0")	Item #2 of Coordinate #2. Enter second desired value.

- * The 'MIN' button allows you to sequence through "INPUT 1", "READ 1", "INPUT 2", and "READ 2" headings.

The 'MAX' button sends you to the value corresponding to "INPUT 1", "READ 1", "INPUT 2", or "READ 2" so you can change it (go to the SUB MENU 2 item).

- ** The 'MIN' button allows you to step through the digits of the applicable number being changed.

The 'MAX' button changes the value of the digit to be displayed.

The 'MENU' button stores the selected values for each input required in "RD.SC.OF". After the last value ("READ 2") has been entered and the 'MENU' button is pressed, the meter display will advance to "IN CNF".

Every underlined item is the factory preset value.

9.2.4 IN CNF (INPUT CONFIGURATION)

Input configuration is used to select:

- 50 or 60 Hz line frequency [INP.1]
- slow or fast read rate [INP.2]
- unipolar or bipolar inputs (temperature inputs must be unipolar [INP.3])
- cold junction compensation [INP.5]
- (INP.6 must be set to "INP.6=0" to disable the input scale and offset since you are not using a transmitter)
- (INP.7 must be set to "INP.7=0")

INP.1 and INP.2 are related to each other. If your power requirements require 50 Hz, you can have optimum integration in FAST read mode (12/sec). In the FAST mode, you need a jumper in the S1A position on the vertical Signal Input Board. If you set the SLOW read rate, this jumper should be removed to avoid overloading the integrator. SLOW read rate produces less noise.

Since you can only select "INP.4=0", this means that you are not utilizing input scale or offset and not disabling the meter's cold junction compensation.

If an external ice-point cell or constant-temperature oven is used to terminate the thermocouple wires (to a pair of copper wires which are then brought to your meter), you do not want to use the Cold-Junction Compensation Board; "INP.5=1" is used in such a case. With a reference-junction oven you would use your meter's input offset capability (IN.SC.OF) to cancel out that temperature so that the linearization table is entered at the proper point.

MENU BUTTON MAIN MENU	MIN/MAX /MENU * BUTTON SUB MENU	DESCRIPTION
"IN CNF":		INPUT CONFIGURATIONS
	"INP.1=0" "INP.1=1"	Line Frequency: 60 Hz 50 Hz
	"INP.2=0" "INP.2=1"	Read Rate: Slow Fast
	"INP.3=0" "INP.3=1"	Input Voltage Unipolar (for T/C): Bipolar
	"INP.4=0" "INP.4=1" "INP.4=2"	Transmitter Type: No Transmitter Not used Not used
	THERMOCOUPLE MODE: "INP.5=0" "INP.5=1"	Cold-Junction Compensation for T/C: Compensated Not Compensated
	RTD MODE: "INP.5=0" "INP.5=1"	3-wire linear 4-wire linear
	"INP.6=0" "INP.6=1"	Input Scale and Offset: Disabled Enabled
	"INP.7=0" "INP.7=1"	Type of Reading: (not used for Temperature, set "INP.7 = 0") Non Ratiometric Not used

* The 'MIN' button allows you to sequence through INP.1, INP.2, INP.3, INP.4, INP.5, INP.6, and INP.7.

The 'MAX' button allows you to select the "0" or "1" state for each "INP" condition.

The 'MENU' button stores the selected values for all "IN CNF" condition(s) changed and advances the meter to "IN.SC.OF". Do not press the 'MENU' button after each change within the submenu or the meter will advance to the next menu item.

Every underlined "0" or "1" state is the factory preset value.

9.2.5 IN.SC.OF (INPUT SCALE AND OFFSET)

Input scale and offset is typically used only when you want to recalibrate your meter (using two input data points). Since your thermocouple is directly connected, ignore this meter function item.

MENU BUTTON MAIN MENU	MIN/MAX * BUTTON SUB MENU 1	MIN/MAX/ MENU ** BUTTON SUB MENU 2	DESCRIPTION
"IN.SC.OF":	INPUT 1		INPUT SCALE & OFFSET
			Input scale and offset in 2-Coordinate Format
	READ 1	000000. ("00000.0")	Item #1 of Coordinate #1. Enter the first value displayed by the meter.
		000000. ("00000.0")	Item #2 of Coordinate #1. Enter first desired value.

continued next page

continued from previous page

MENU BUTTON MAIN MENU	MIN/MAX * BUTTON SUB MENU 1	MIN/MAX/ MENU ** BUTTON SUB MENU 2	DESCRIPTION
	INPUT 2	000000. (<u>"10000.0"</u>)	Item #1 of Coordinate #2. Enter the second value displayed by the meter.
	READ 2	000000. (<u>"10000.0"</u>)	Item #2 of Coordinate #2. Enter second desired value.

* The 'MIN' button allows you to sequence through "INPUT 1", "READ 1", "INPUT 2", and "READ 2" headings.

The 'MAX' button sends you to the value that corresponds to "INPUT 1", "READ 1", "INPUT 2", or "READ 2" so you can change it (go to the SUB MENU 2 item).

** The 'MIN' button allows you to sequence through the digits of the applicable number being changed.

The 'MAX' button changes the value of the digit to be displayed.

The 'MENU' button stores the selected values for each input required in "IN.SC.OF". After the last value ("READ 2") has been entered and the 'MENU' button is pressed, the meter display will advance to "DEC PT".

Pressing the 'MENU' button allows you go to the next SUB MENU 1 item automatically.

After changing the last value at the bottom of the chart, pressing the 'MENU' button once more stores everything that was changed and advances the meter to the next configuration ("DEC PT").

Every underlined item is the factory preset value.

9.2.6 DEC PT (DECIMAL POINT)

Decimal point is used to select the resolution of your meter display such as in one degree, tenths of a degree, and hundredths of a degree. (This also applies to ohms, but the six-digit display permits milliohm units when RDG SC is set equal to 10 or more).

For thermocouples, RTDs and ohms, the decimal-point control is selected as "active" ("RDG.2=0"), i.e., changing the decimal point location moves the data digits along with it.

"FFFFF.F" is often used, since the linearization conformity is 0.2°F (0.1°C).

If "ERR 01" is displayed, check that "RDG OF" is within the display range.

MENU BUTTON MAIN MENU	MIN/MAX/ MENU * BUTTON CONDITION	DESCRIPTION
"DEC PT":	"FFFFFF." <u>"FFFFF.F"</u> "FFFF.FF"	DECIMAL POINT POSITION Position 1 (one-degree) Position 2 (tenths of a degree) Position 3 (hundredths of a degree)

* Press the 'MIN' button to show all "F's" on the display.

Press the 'MAX' button to move the decimal point.

Press the 'MENU' button to store the decimal point location and the meter will advance to "CNT BY".

The underlined item is the factory preset value.

9.2.7 CNT BY (COUNT BY)

Count by is used to round off the meter values by 1's, 2's, 5's, 10's, 20's, 50's, or 100's. This feature is normally set to "001" so that the display shows all possible values for the least-significant digit.

If the combination of input-signal noise and selected degree resolution is high, however, your meter can round off the display to the nearest 2, 5, 10, 20, 50 or even 100 digits. This can eliminate annoying display jitter without introducing any filter time delays.

For most thermocouple applications, however, the read rate and Adaptive Bandwidth Control filter of your meter are much faster than the thermal time constants, so that "CNT BY" should be set to 001.

MENU BUTTON MAIN MENU	MIN/MAX/ MENU * BUTTON SUB MENU	DESCRIPTION
"CNT BY":	<u>"001"</u> "002" "005" "010" "020" "050" "100"	COUNT BY ROUNDING OFF THE VALUE (the decimal point position is ignored)

* Press the 'MIN' button to show "001", "002", "005", "010", "020", "050", or "100".

Press the 'MAX' button to select one of the above.

Press the 'MENU' button to store the Count By number and the meter will advance to "FIL.CNF".

The underlined item is the factory preset value.

9.2.8 FIL.CNF (FILTER CONFIGURATION)

Filter configuration is used to select:

- Adaptive Bandwidth Control[^] (ABC) filtering or moving average filter [FIL.1]
- whether the value displayed on the meter is filtered or unfiltered [FIL.2]
- whether the value sent to the optional analog output is filtered or unfiltered [FIL.3]

“FIL.1=0” for Adaptive Bandwidth Control (ABC filtering, which averages over a larger number of samples when the input is not moving, but drops down to no averaging for systematic input changes). “FIL.1=1” is for averaging over a fixed number of samples. The number of samples to be used is selected in “FIL TI”.

“FIL.3=0” removes the selected filtering from the analog output (if that option is installed in your meter). “FIL.3=1” puts the selected filtering on that output. Usually you choose “FIL.3=0”, relying on the signal conditioning available at the device receiving the analog output data.

MENU BUTTON MAIN MENU	MIN/MAX/ MENU * BUTTON SUB MENU	DESCRIPTION
“FIL.CNF”:	“FIL.1=0” “FIL.1=1” “FIL.2=0” “FIL.2=1” “FIL.3=0” “FIL.3=1” “FIL.3=2” “FIL.3=3”	FILTER CONFIGURATION Filter Type: ABC Filter Moving Average Filter Value to be displayed: Unfiltered Filtered Value to be transmitted on Analog Output Unfiltered Filtered Peak value Valley value

* The 'MIN' button allows you to sequence through FIL.1, FIL.2, and FIL.3.

The 'MAX' button allows you to select the "0", "1", "2", or "3" state for each "FIL" condition.

The 'MENU' button stores the selected values for all "FIL.CNF" condition(s) changed and advances the meter to "FIL TI". Do not press the 'MENU' button after each change within the submenu or the meter will advance to the next menu item.

^ Adaptive Bandwidth Control takes the average of the samples except when the input is rapidly changing. Patent applied for.

Every underlined "0", "1", "2", or "3" is the factory preset value.

9.2.9 FIL TI (FILTER TIME CONSTANT)

Filter time constant is used to determine the number of readings the meter will average before displaying an input value. The choices are 001, 002, 004, 008, 016, 032, 064, or 128.

For fixed filtering, the averaged number of samples is fixed; for Automatic Bandwidth Control, the chosen value is the maximum number of samples in the average computed by ABC when the input is not changing significantly (ABC, for slowly-moving signals, filters by averaging the "TI" number of samples, but follows signal changes rapidly by decreasing that averaging number).

Pressing the 'MENU' button stores your selection and moves on to "RESET 1" and then to "RUN" (unless setpoints, outputs, or communications have been unlocked for programming change).

MENU BUTTON MAIN MENU	MIN/MAX/ MENU * BUTTON SUB MENU	DESCRIPTION
"FIL TP":	"001" "002" "004" "008" "016" "032" <u>"064"</u> "128"	FILTER TIME CONSTANT Number of readings used in averaging.

* Press the 'MIN' button to show "001", "002", "004", "008", "016", "032", "064" or "128".

Press the 'MAX' button to select one of the above.

Press the 'MENU' button to store the selection made and to advance the meter to the next menu ("SP CNF").

The underlined item is the factory preset value.

9.2.10 SP CNF (SETPOINTS 1 & 2 CONFIGURATION)

Setpoint configuration is used to select:

- the active zone of each setpoint to above and below the setting [SPC.1 & SPC.4]
- whether the open-collector output is on or off [SPC.2 & SPC.5]
- whether the reading compared with the setpoints is filtered or unfiltered [SPC.3 & SPC.6]
- enabled or disabled setpoints [SPC.7]
- enabled or disabled setpoint LED displays [SPC.8]

MENU BUTTON MAIN MENU	MIN/MAX/ MENU * BUTTON SUB MENU	DESCRIPTION
"SP CNF":		SETPOINTS 1 & 2 CONFIGURATIONS
	" <u>SPC.1=0</u> "	Setpoint 1 Active Zone: Above
	"SPC.1=1"	Below
	" <u>SPC.2=0</u> "	Setpoint 1 open-collector or relay output Active ON or OFF: On
	"SPC.2=1"	Off
	" <u>SPC.3=0</u> "	Filtered/unfiltered reading compared with Setpoint 1 value: Unfiltered
	" <u>SPC.3=1</u> "	Filtered
	" <u>SPC.4=0</u> "	Setpoint 2 Active zone: Above
	"SPC.4=1"	Below
	" <u>SPC.5=0</u> "	Setpoint 2 open-collector or relay output Active ON or OFF: On
	"SPC.5=1"	Off
	" <u>SPC.6=0</u> "	Filtered/unfiltered reading compared with Setpoint 2 value: Unfiltered
	" <u>SPC.6=1</u> "	Filtered
	" <u>SPC.7=0</u> "	Setpoints 1 & 2 action: Enabled
	"SPC.7=1"	Disabled
	" <u>SPC.8=0</u> "	Setpoint 1 & 2 LEDs action: Enabled
"SPC.8=1"	Disabled	

* The 'MIN' button allows you to sequence through SPC.1, SPC.2, SPC.3, SPC.4, SPC.5, SPC.6, SPC.7 and SPC.8.

The 'MAX' button allows you to select the "0" or "1" state for each "SPC" condition.

The 'MENU' button stores the selected values for each "SPC" condition changed and advances the meter to the next configuration ("AL CNF").

Every underlined "0" or "1" is the factory preset value.

9.2.11 AL CNF (ALARM CONFIGURATION)

Alarm configuration is used to select:

- the active zone for each alarm point to above or below the setting [ALC.1 & ALC.4]
- whether the open-collector output is on or off [ALC.2 & ALC.5]
- whether the readings compared with the alarm points are filtered or unfiltered [ALC.3 & ALC.6]
- enabled or disabled alarm points [ALC.7]

MENU BUTTON MAIN MENU	MIN/MAX/ MENU * BUTTON SUB MENU	DESCRIPTION
"AL CNF":	<p>"<u>ALC.1=0</u>" "ALC.1=1"</p> <p>"<u>ALC.2=0</u>" "ALC.2=1"</p>	<p>ALARMS 1 & 2 (SETPOINTS 3 & 4) CONFIGURATIONS</p> <p>Alarm 1 Active zone (Setpoint 3): Above Below</p> <p>Alarm 1 open-collector or relay output Active ON or OFF: On Off</p>

continued next page

continued from previous page

MENU BUTTON MAIN MENU	MIN/MAX/ MENU * BUTTON SUB MENU	DESCRIPTION
	"ALC.3=0" <u>"ALC.3=1"</u>	Filtered/unfiltered reading compared with Alarm 1 (Setpoint 3) value: Unfiltered Filtered
	" <u>ALC.4=0</u> " "ALC.4=1"	Alarm 2 Active zone (Setpoint 4): Above Below
	" <u>ALC.5=0</u> " "ALC.5=1"	Alarm 2 open-collector or relay output Active ON or OFF: On Off
	"ALC.6=0" <u>"ALC.6=1"</u>	Filtered/unfiltered reading compared with Alarm 2 (Setpoint 4) value: Unfiltered Filtered
	" <u>ALC.7=0</u> " "ALC.7=1"	Alarms 1 & 2 (Setpoints 3 & 4) action and LEDs: Enabled Disabled
	" <u>ALC.8=0</u> " "ALC.8=1"	Alarm reset at P2-11 connector: Disabled Enabled

* The 'MIN' button allows you to sequence through ALC.1, ALC.2, ALC.3, ALC.4, ALC.5, ALC.6, ALC.7 and ALC.8.

The 'MAX' button allows you to select the "0" or "1" state for each "ALC" condition.

The 'MENU' button stores the selected values for each "ALC" condition changed and advances the meter to the next configuration ("AL FNC").

Every underlined "0" or "1" is the factory preset value.

9.2.12 AL FNC (ALARM FUNCTION)

Alarm function is used to select:

- whether the alarms are used in the process, high-deviation, low-deviation or band deviation modes [ALF.1 & ALF.3]
- whether or not to latch the alarms [ALF.2 & ALF.4]

MENU BUTTON MAIN MENU	MIN/MAX/ MENU * BUTTON SUB MENU	DESCRIPTION
"AL FNC":	<p>"<u>ALF.1=0</u>"</p> <p>"ALF.1=1"</p> <p>"ALF.1=2"</p> <p>"ALF.1=3"</p> <p>"<u>ALF.2=0</u>"</p> <p>"ALF.2=1"</p> <p>"<u>ALF.3=0</u>"</p> <p>"ALF.3=1"</p> <p>"ALF.3=2"</p> <p>"ALF.3=3"</p> <p>"<u>ALF.4=0</u>"</p> <p>"ALF.4=1"</p>	<p>ALARMS 1 & 2 FUNCTION</p> <p>Alarm 1 State: Process Mode High Deviation Mode Low Deviation Mode Band Deviation Mode</p> <p>Alarm 1 Latch Action: Unlatched Latched</p> <p>Alarm 2 State: Process Mode. Process Mode means the deadband is equally above and below the setpoint. High Deviation Mode Low Deviation Mode Band Deviation Mode</p> <p>Alarm 2 Latch Action: Unlatched Latched</p>

- * The 'MIN' button allows you to sequence through ALF.1, ALF.2, ALF.3 and ALF.4.

The 'MAX' button allows you to select the "0", "1", "2", or "3" state for each "ALF" condition.

The 'MENU' button stores the selected values for each "ALF" condition changed and advances the meter to the next configuration ("AL RDG").

Every underlined item is the factory preset value.

9.2.13 AL RDG (ALARM READINGS)

Alarm reading is used to select the number of readings (from 01 to 15) the meter must make prior to activating the alarms.

MENU BUTTON MAIN MENU	MIN/MAX/ MENU * BUTTON SUB MENU	DESCRIPTION
"AL RDG":	"00 00" ("03 03")	ALARM NUMBER OF READINGS Number of readings to delay activation of Alarms 1 & 2 (from "01" to "15") (AL1), (AL2)

- * Press the 'MIN' button to show the current number of readings on the display (left pair of digits are flashing).

The 'MAX' button is used to change the value of the flashing digits (from 01 to 15).

Pressing the 'MIN' button allows you go to the second set of digits.

The 'MAX' button is used to change the value of the flashing digits.

After changing the last number, if necessary, pressing the 'MENU' button stores everything that was changed and advances the meter to the next configuration ("SP DB").

The underlined item is the factory preset value.

9.2.14 SP DB (SETPOINT DEADBAND)

Setpoint deadband is used to select the amount of hysteresis for the setpoints (programmable from "0000" to "9999").

MENU BUTTON MAIN MENU	MIN/MAX/ MENU * BUTTON SUB MENU	DESCRIPTION
"SP DB":	"0000" ("00 <u>20</u> ")	SETPOINTS 1 & 2 DEADBAND Hysteresis for (w/system decimal points) Setpoints 1 and 2 (Programmable from "0000" to "9999")

* Press the 'MIN' button to show the value on the display.

The 'MIN' button also allows you to sequence through the digits of the number being changed.

The 'MAX' button changes the value of the digit to be displayed.

The 'MENU' button stores the selected values for each "SP DB" condition changed and advances the meter to the next configuration ("AL DB"):

The underlined item is the factory preset value.

9.2.15 AL DB (ALARM DEADBAND)

Alarm deadband is used to select the amount of hysteresis for the alarms (programmable from "0000" to "9999").

MENU BUTTON MAIN MENU	MIN/MAX/ MENU * BUTTON SUB MENU	DESCRIPTION
"AL DB":	"0000" ("00 <u>20</u> ")	ALARMS 1 & 2 DEADBAND Hysteresis for (w/System decimal points) Alarms 1 & 2 (Programmable from "0000" to "9999")

* Press the 'MIN' button to show the value on the display.

The 'MIN' button also allows you to sequence through the digits of the number being changed.

The 'MAX' button changes the value of the digit to be displayed.

Press the 'MENU' button to store the changes and advances the meter to the next configuration ("OUT.CNF").

The underlined item is the factory preset value.

9.2.16 OUT.CNF (OUTPUT CONFIGURATION)

Output configuration is used to select:

- whether or not to send data to the optional analog output board [OUT.1]
- the analog output signal of 0-10 V dc or 4-20 mA DC [OUT.2]
- whether or not to send data to the optional BCD output board [OUT.3]
- to send peak value via the optional BCD output board [OUT.4]
- to select type of BCD output [OUT.5]
- enable or disable the flashing display [OUT.6]

MENU BUTTON MAIN MENU	MIN/MAX/ MENU * BUTTON SUB MENU	DESCRIPTION
"OUT.CNF":	<p>"<u>OUT.1=0</u>" "OUT.1=1"</p> <p>"OUT.2=0" "<u>OUT.2=1</u>"</p>	<p>OUTPUT CONFIGURATION</p> <p>Data on the Analog Output Board: Disabled Enabled</p> <p>Analog Output Mode: 0-1 V, 0-5 V, 1-5 V, 0-10 V 0-20 mA or 4-20 mA</p>

continued next page

continued from previous page

MENU BUTTON MAIN MENU	MIN/MAX/ MENU * BUTTON SUB MENU	DESCRIPTION
	<u>"OUT.3=0"</u> "OUT.3=1"	Data out on Parallel BCD Board: Disabled Enabled
	<u>"OUT.4=0"</u> "OUT.4=1"	Type of data out on BCD Board: Display Peak
	"OUT.5=0" <u>"OUT.5=1"</u>	BCD Output: Used for standard parallel printers. Used for Specialty printers.
	<u>"OUT.6=0"</u> "OUT.6=1" "OUT.6=2" "OUT.6=3" "OUT.6=4" "OUT.6=5"	Type of Display Flashing: Disabled - display flashing. SP1 active - display flashing. SP2 active - display flashing. SP3 active - display flashing. SP4 active - display flashing. any SP active - display flashing.

* The 'MIN' button allows you to sequence through OUT.1, OUT.2, OUT.3, OUT.4, OUT.5, and OUT.6.

The 'MAX' button allows you to select the "0", "1", "2", "3", "4" or "5" state for each "OUT" condition.

The 'MENU' button stores the selected values for each "OUT" condition changed and advances the meter to the next configuration ("OT.SC.OF").

Every underlined item is the factory preset value.

9.2.17 OT.SC.OF (OUTPUT SCALE AND OFFSET)**Meter Function Menus**

Output scale and offset is used to calibrate your optional analog output to correspond to the engineering units you desire.

MENU BUTTON MAIN MENU	MIN/MAX * BUTTON SUB MENU 1	MIN/MAX/ MENU ** BUTTON SUB MENU 2	DESCRIPTION
"OT.SC.OF":	READ 1	000000. ("000000.0")	OUTPUT SCALE AND OFFSET Item #1 of Coordinate #1. Enter the first value displayed by the meter.
		OUTPT1	Item #2 of Coordinate #1. Enter first desired output value.
	READ 2	00.0000 ("04.0000")	Item #1 of Coordinate #2. Enter the second value displayed by the meter.
		OUTPT2	Item #2 of Coordinate #2. Enter second desired output value.

* The 'MIN' button allows you to sequence through "READ 1", "OUTPT1", "READ 2", and "OUTPT2" headings.

The 'MAX' button sends you to the value corresponding to "READ 1", "OUTPT1", "READ 2", and "OUTPT2" so you can change it (go to the SUB MENU 2 item).

** The 'MIN' button allows you to step through the digits of the applicable number being changed.

The 'MAX' button changes the value of the digit to be displayed.

The 'MENU' button stores the selected values for each input required in "OT.SC.OF". After the last value ("READ 2") has been entered and the 'MENU' button is pressed, the meter display will advance to "BAUD".

Every underlined item is the factory preset value.

9.2.18 BAUD (BAUD RATE)

Baud is used to select the baud rate for communication via the optional RS-232 or RS-485 communications boards. The choices are 300, 600, 1200, 2400, 4800, 9600, and 19200.

MENU BUTTON MAIN MENU	MIN/MAX/ MENU * BUTTON SUB MENU	DESCRIPTION
"BAUD":	"00300" "00600" "01200" "02400" "04800" "09600" "19200"	BAUD RATE Select baud rate for communications via RS-232 or RS-485

* Press the 'MIN' button to show "00300", "00600", "01200", "02400", "04800", "09600", or "19200".

Press the 'MAX' button to select one of the above.

Press the 'MENU' button to store the changes and the meter advances to the next configuration ("SERCNF").

The underlined item is the factory preset value.

9.2.19 SERCNF (SERIAL COMMUNICATION CONFIGURATION)

Serial communication configuration is used to select:

- no parity, odd parity, or even parity for communications [SER.1]
- 1 stop bit or 2 stop bits [SER.2]

MENU BUTTON MAIN MENU	MIN/MAX/ MENU * BUTTON SUB MENU	DESCRIPTION
"SERCNF":	<p>"SER.1=0" "SER.1=1" "SER.1=2"</p> <p>"SER.2=0" "SER.2=1"</p>	<p>SERIAL COMMUNICATION CONFIGURATION</p> <p>Select parity for communications via RS-232 or RS-485: No parity Odd parity Even parity</p> <p>Select stop bits for communications via RS-232 or RS-485: 1 Stop Bit 2 Stop Bits</p>

* The 'MIN' button allows you to toggle between SER.1 and SER.2.

The 'MAX' button allows you to select the "0", "1", or "2" state for each "SER" condition.

The 'MENU' button stores the selected values for each "SER" condition changed and advances the meter to the next configuration ("ADDRES").

Every underlined "0", "1" or "2" is the factory preset value.

9.2.20 ADDRESS (MULTIPOINT COMMUNICATIONS DEVICE ADDRESS)

Address is used to give each meter a unique address while on a local area network using the optional RS-485 board.

MENU BUTTON MAIN MENU	MIN/MAX/ MENU * BUTTON SUB MENU	DESCRIPTION
"ADDRES":	"000" (<u>"001"</u>)	MULTIPOINT COMMUNICATIONS DEVICE ADDRESS Enter address as an integer value: "000" to "199"

* Press the 'MIN' button to show the value on the display.

The 'MIN' button also allows you to change the position of the digit being changed.

The 'MAX' button changes the value of the digit to be displayed.

Press the 'MENU' button to store the changes and advances the meter to the next configuration ("DAT FT").

The underlined item is the factory preset value.

9.2.21 DAT FT (DATA FORMAT)

Data format is used to set all the parameters to be transmitted via the optional RS-232 or RS-485 serial communications board.

Data format allows you to select:

- whether to transmit Alarm 1 or 2 status character [DAT.1]
- whether to transmit peak and valley status character [DAT.2]
- whether or not the data transmitted is filtered or unfiltered [DAT.3 & DAT.4]

- whether or not to transmit the peak and valley readings [DAT.5 & DAT.6]
- the type of separator [DAT.7]
- whether or not to transmit the unit of measure [DAT.8]

MENU BUTTON MAIN MENU	MIN/MAX/ MENU * BUTTON SUB MENU	DESCRIPTION
"DAT FT":		DATA FORMAT
	" <u>DAT.1=0</u> " "DAT.1=1"	Alarms 1 & 2 Status Character: Excluded Included
	" <u>DAT.2=0</u> " "DAT.2=1"	HI/LO (Peak/Valley) Status Character: Excluded Included
	" <u>DAT.3=0</u> " "DAT.3=1"	Type of data to be transmitted: Unfiltered Filtered
	" <u>DAT.4=0</u> " "DAT.4=1"	Filtered value to be transmitted: No Yes
	" <u>DAT.5=0</u> " "DAT.5=1"	Peak value to be transmitted: No Yes
	" <u>DAT.6=0</u> " "DAT.6=1"	Valley value to be transmitted: No Yes
	" <u>DAT.7=0</u> " "DAT.7=1"	Separator for above items: Space <CR>
	" <u>DAT.8=0</u> " "DAT.8=1"	Unit of measurement to be transmitted: No Yes

- * The 'MIN' button allows you to sequence through DAT.1, DAT.2, DAT.3, DAT.4, DAT.5, DAT.6, DAT.7, and DAT.8.

The 'MAX' button allows you to select the "0" or "1" state for each "DAT" condition.

The 'MENU' button stores the selected values for each "DAT" condition changed and advances the meter to the next configuration ("BUS FT").

Every underlined "0" or "1" is the factory preset value.

9.2.22 BUS FT (BUS FORMAT)

Bus format is to select:

- whether or not to include check sum with reading [BUS.1]
- whether or not to include line feeds [BUS.2]
- whether or not to have the meter respond in echo mode [BUS.3]
- multipoint or point-to-point mode [BUS.4]
- (if in point-to-point mode) select whether to communicate continuously or on command [BUS.5]
- whether a message character is used in handshake or continuous mode [BUS.6]
- whether or not you have installed the RS-485 board [BUS.7]
- whether or not to enable the external print command at P2-11.

MENU BUTTON MAIN MENU	MIN/MAX/ MENU * BUTTON SUB MENU	DESCRIPTION
"BUS FT":	<p><u>"BUS.1=0"</u> "BUS.1=1"</p> <p><u>"BUS.2=0"</u> "BUS.2=1"</p>	<p>BUS FORMAT</p> <p>Check sum with reading: Excluded Included</p> <p>Line feed following all <CR>'s: Excluded Included</p>

continued next page

continued from previous page

MENU BUTTON MAIN MENU	MIN/MAX/ MENU * BUTTON SUB MENU	DESCRIPTION
	"BUS.3=0" <u>"BUS.3=1"</u>	Response from the meter (echo): No Yes
	<u>"BUS.4=0"</u> "BUS.4=1"	Point to Point mode or Multipoint mode: Pt-Pt Multi-Pt
	"BUS.5=0" <u>"BUS.5=1"</u>	Point-to-Point mode only: Continuous On Command
	<u>"BUS.6=0"</u> "BUS.6=1"	Handshake if continuous mode: Message Character
	<u>"BUS.7=0"</u> "BUS.7=1"	RS-485 Board installed?: Not installed Installed
	"BUS.8=0" <u>"BUS.8=1"</u>	Print Command at P2-11: Disabled Enabled

* The 'MIN' button allows you to sequence through BUS.1, BUS.2, BUS.3, BUS.4, BUS.5, BUS.6, BUS.7 and BUS.8.

The 'MAX' button allows you to select the "0" or "1" state for each "BUS" condition.

The 'MENU' button stores the selected values for each "BUS" condition changed and advances the meter to the next configuration ("SERCNT").

Every underlined "0" or "1" state is the factory preset value.

9.2.23 SERCNT (SERIAL COUNT)

Serial count is used to program the number of readings the meter must take (programmable from "00001" to "59,999") between transmissions of data via the optional RS-232 or RS-485 serial communications board.

Once you are done with the changes, press the 'MENU' button to display the normal operating display. The meter advances to run mode showing the currently measured values. Pressing the 'RESET' button two times allows you to return to the run mode.

MENU BUTTON MAIN MENU	MIN/MAX/ MENU * BUTTON SUB MENU	DESCRIPTION
"SERCNT":	"00000" (<u>"00001"</u>)	SERIAL COUNT This specifies the number of readings between data transmissions: "00001" to "59999"

* Press the 'MIN' button to show the value on the display.

The 'MIN' button also allows you to change the position of the digit being changed.

The 'MAX' button changes the value of the digit to be displayed.

Press the 'MENU' button to store the changes and advances the meter to "RESET 2" and returns to the run mode.

The underlined item is the factory preset value.

NOTE: After you complete your programming you may want to go back and remove the jumper in S3A position on the main board to insure against any unauthorized changes.

9.2.24 ANALOG OUTPUT CALIBRATION NUMBERS

The analog output calibration numbers (see Figure 12-1) are printed on the optional analog output board. These four numbers (CAL VZ, CAL VS, CAL mAZ, and CAL mAS) must be entered into the meter to ensure that the analog output board is calibrated with the microprocessor.

MENU BUTTON MAIN MENU	MIN/MAX/ MENU * BUTTON SUB MENU	DESCRIPTION
"CAL VZ"	0 to 59999	Calibration number marked on the analog output board must be entered for voltage zero.
"CAL VS"	0 to 59999	Calibration number marked on the analog output board must be entered for voltage span.
"CAL mAZ"	0 to 59999	Calibration number marked on the analog output board must be entered for current zero.
"CAL mAS"	0 to 59999	Calibration number marked on the analog output board must be entered for current span.

NOTE: After you complete your programming you may want to go back and remove the jumper in S3A position on the main board to insure against any unauthorized changes.

Once you are done with the changes, press the 'MENU' button to display. The meter advances to run mode showing the currently measured values.

10. Setpoints/Alarms

Setpoints 1 through 4 can be configured for a very large variety of zone and level signalling.

SP1 and SP2 have balanced configurable hysteresis and are non-latching, suitable for control-level signalling. SP3 and SP4 are often used as ALarm 1 and ALarm 2, because they have single-sided hysteresis and can be configured for latching action.

The levels of these setpoints are entered during run mode via the front-panel pushbuttons (refer to Section 10.11). Many performance options are entered during the configuration mode (refer to Sections 10.2 through 10.10).

10.1 FEATURES OVERVIEW

1. Four full-range levels with many menu programmable features.
2. Independent operation or ganged action (including guard-band assignments).
3. Active above or below level, outside or inside band.
4. SP1 and SP2 have configurable hysteresis, 50% on either side of setpoint.
5. SP3 and SP4 have configurable hysteresis, 100% on inactive side.
6. SP3 and SP4 is configurable for latching action.
7. Setpoint levels can be compared to the unfiltered or filtered input signal measurements.
8. Configurable delays in alarm action.
9. Individual front-panel LED indicators.
10. Four (4) open-collector transistor outputs with clamping diodes, are isolated from signal input.
11. Setpoints can be displayed and reset as desired without interrupting measurements.

Setpoints 1 and 2 have selectable hysteresis, allocated 50% on either side of the setpoint level. A single setpoint can now generate on/off control signals for an operating region defined by the hysteresis. Refer to Figures 10-1 and 10-2 to understand how hysteresis works:

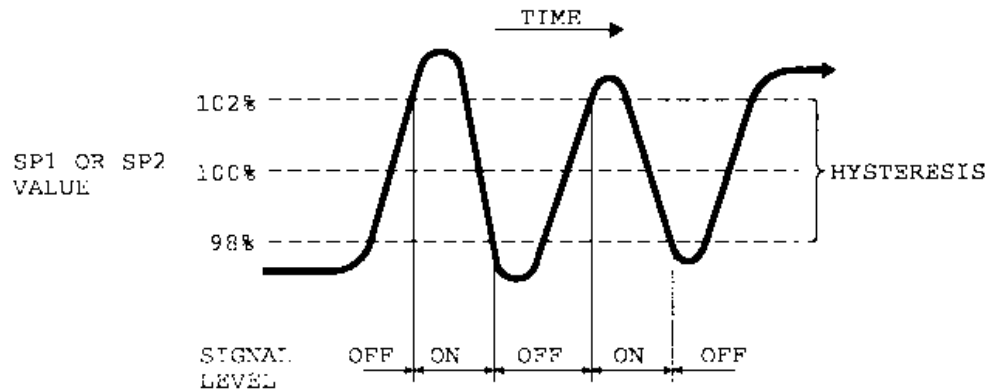

Figure 10-1. Setpoints 1 & 2 Action
(Setpoint at 100 with 4% hysteresis)

These two setpoints have selectable single-sided hysteresis. When used as alarms, the action is immediate (unless a delay is programmed) going into the alarm zone but turning off is deferred (if latching is not programmed) by the hysteresis amount.

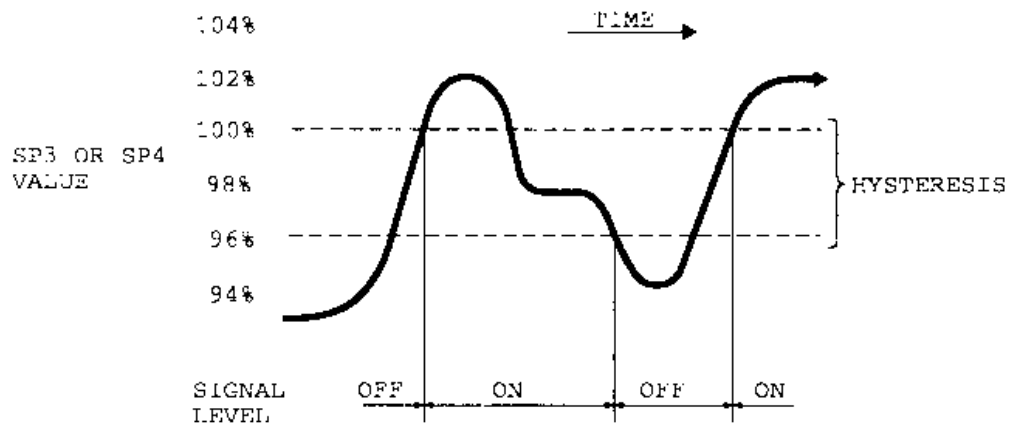

Figure 10-2. Setpoints 3 & 4 Action
(for Low Alarm with Relay on at -100, relay off at -96 with a hysteresis of 4)

You are now able to program the setpoint features (as described in the following sections).

10.2 UNLOCKING THE FEATURES

All setpoint values and features can be set via the front-panel buttons or the optional serial communications boards (RS-232 or RS-422/485). Control from the front-panel buttons can be locked out by jumpers on S3A and S3C on the main board or by setting lockout bits "L3C.2", and "L3C.6" in Lockout configuration "L3 CNF".

1. Check that main board jumpers S3A and S3C are installed (to permit memory storage of program and data along with button controls).

NOTE: Jumper S3B should NOT be installed. This jumper is reserved for factory recalibration!

2. Press the 'MENU' button to see "L1 CNF" and then press the 'MIN' button to view "L1C.1=0" if "SP 1" is unlocked. If "L1C.1=1", change to equal "0" by pressing the 'MAX' button.
3. Press the 'MIN' button again to advance to "L1C.2" and set equal to "0" to unlock "SP 2".
4. Repeat for "L1C.3=0" and "L1C.4=0" to access "SP 3" and "SP 4".
5. Press the 'MENU' button to save these choices and advance to "L2 CNF". Skip over "L2 CNF" by pressing the 'MENU' button and advance to "L3 CNF".
6. Press the 'MIN' and 'MAX' buttons to set "L3C.2=0", "L3C.3=0", "L3C.4=0", "L3C.5=0", "L3C.6=0", "L3C.7=0" to gain access to the programming for the setpoints. All changes are then saved by pressing the 'MENU' button.

10.3 SELECTING "SP CNF" SETPOINT CONFIGURATION FEATURES

These eight bits select the modes for "SP 1" and "SP 2" (see Section 10.5 for "SP 3" and "SP 4").

1. Press the 'MENU' button until "SP CNF" is displayed, then press the 'MIN' button to sequence through the selections. Use the 'MAX' button to choose alternate choice.

2. "SPC.1=0" makes "SP 1" active ABOVE its level;
"SPC.1=1" sets "SP 1" active BELOW.
3. "SPC.2=0" turns "SP 1" transistor ON when "SP 1" is active.
"SPC.2=1" turns it OFF.
4. "SPC.3=0" compares the "SP 1" level to the UNFILTERED measurements.
"SPC.3=1" compares "SP 1" to the FILTERED measurements.
5. "SPC.4=0" makes "SP 2" active ABOVE setpoint.
"SPC.4=1" makes "SP 2" active BELOW setpoint.
6. "SPC.5=0" turns "SP 2" transistor ON when "SP 2" is active.
"SPC.5=1" turns it OFF.
7. "SPC.6=0" compares the "SP 2" level to the UNFILTERED measurements.
"SPC.6=1" compares "SP 2" to the FILTERED measurements.
8. "SPC.7=0" Enables both setpoints 1 and 2.
"SPC.7=1" Disables both setpoints 1 and 2.
9. "SPC.8=0" ENABLES the two front-panel LED indicators for setpoints 1 and 2 when you have chosen "SPC.7=0".
"SPC.8=1" DISABLES the two front-panel LED indicators for setpoints 1 and 2. (use with caution; recommended only when other external over-range indicators are present).
10. Press the 'MENU' button to store your selections and advance to "AL CNF" (Alarm Configuration).

10.4 DEVIATION FUNCTION FOR ALARMS

Deviation functions apply to Alarms 1 and 2 (Setpoints 3 and 4) and act as buffer zones to control setpoint action. The Alarm 1 deviation is the sum of the Alarm 1 value plus the Setpoint 1 value; the Alarm 2 deviation is the Alarm 2 value plus the Setpoint 2 value. The four types of deviation functions are Process (no deviation), High, Low, and Deadband. The following illustrate the ways in which the deviation function alters the alarm response.

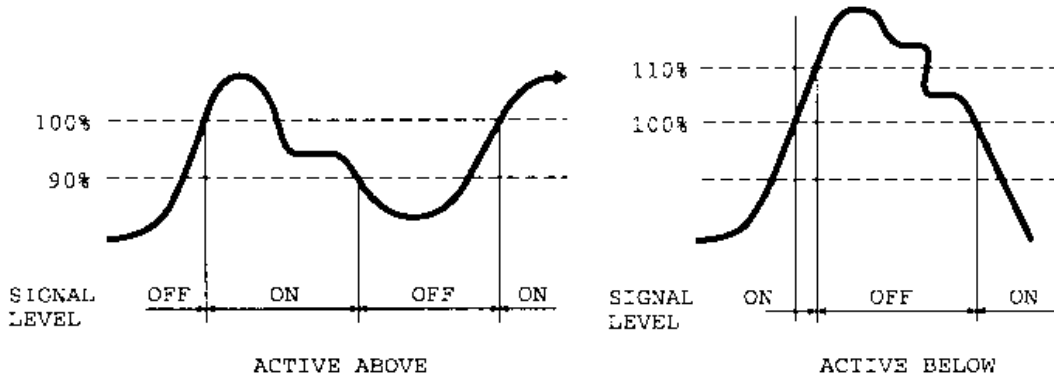

Figure 10-3. Process Deviation

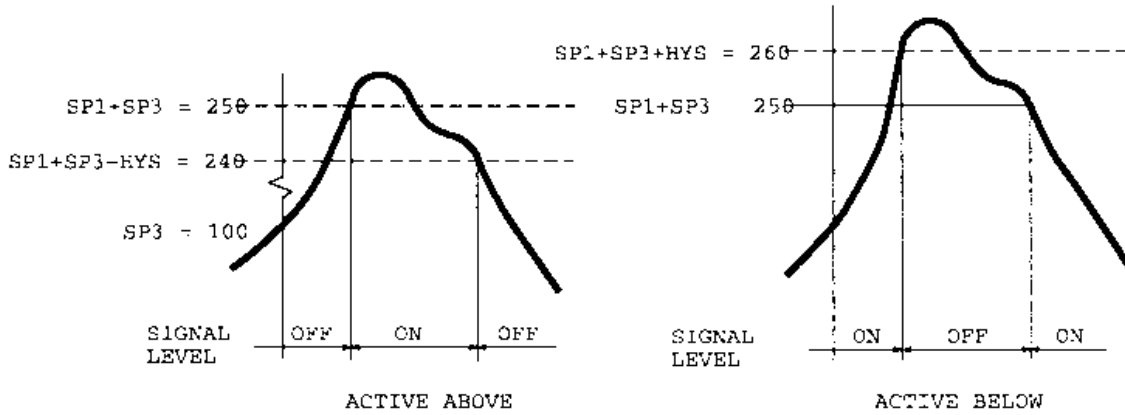

Figure 10-4. High Deviation for both Active Above and Active Below

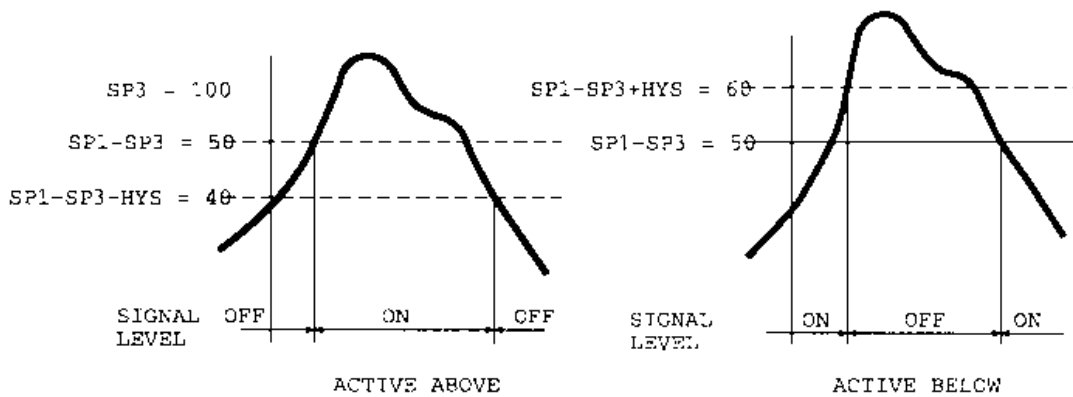

Figure 10-5. Low Deviation for both Active Above and Active Below

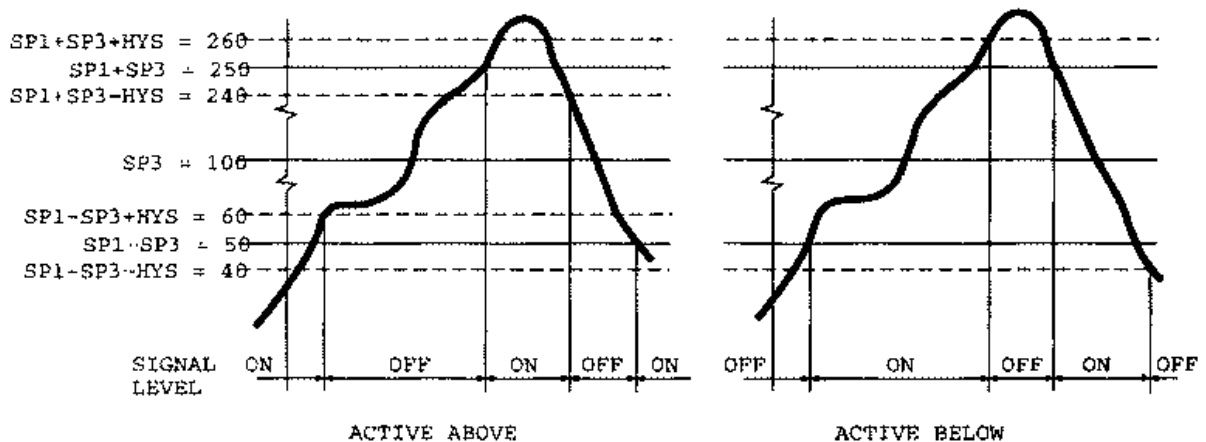

Figure 10-6. Band Deviation for both Active Above and Active Below

10.5 SELECTING "AL CNF" ALARM CONFIGURATION FEATURES

These bits offer the same selections for "SP 3" and "SP 4" as "SP CNF" did for "SP 1" and "SP 2", except for the last bit, which controls "SP 3" and "SP 4" LATCH reset.

1. "ALC.1=0" makes Alarm 1 (Setpoint 3) active above the Setpoint value.
- "ALC.1=1" makes Alarm 1 (Setpoint 3) active below the Setpoint value.

When Alarm 1 (Setpoint 3) is assigned to place a band about the Setpoint 1 level (by setting "ALF.1=3", described in Section 10.6), "ALC.1=0" makes Alarm 1 (Setpoint 3) active ABOVE and BELOW the band (OUTSIDE the band), with the chosen hysteresis for Alarm 1 (Setpoint 3) now inside the band. If "ALC.1=1", Alarm 1 (Setpoint 3) is active INSIDE the band, with the chosen hysteresis for Alarm 1 (Setpoint 3) now outside the band.

Figure 10-7 Illustrates the Alarm configuration for hysteresis.

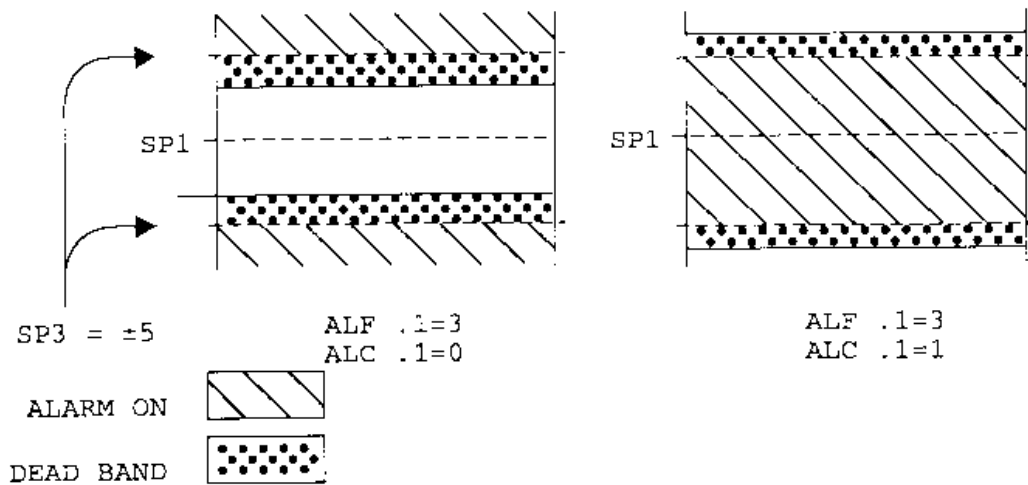

Figure 10-7. ALCNF Hysteresis

2. "ALC.2=0" turns the Alarm 1 (Setpoint 3) open-collector output ON when Setpoint 3 is active.
"ALC.2=1" turns it OFF.
3. "ALC.3=0" compares the Alarm 1 (Setpoint 3) level to the UNFILTERED measurements.
"ALC.3=1" compares the Alarm 1 (Setpoint 3) level to the FILTERED measurements.
4. "ALC.4=0" makes Alarm 2 (Setpoint 4) active ABOVE the Setpoint value.
"ALC.4=1" makes Alarm 2 (Setpoint 4) active BELOW the Setpoint value.

When Alarm 2 (Setpoint 4) is assigned to place a band about the Setpoint 4 level (by setting "ALF.1=3", described in Section 10.6), "ALC.4=0" makes Alarm 2 (Setpoint 4) active ABOVE and BELOW the band (OUTSIDE the band), with the chosen hysteresis for Alarm 2 (Setpoint 4) now inside the band. If "ALC.4=1", Alarm 2 (Setpoint 4) is active INSIDE the band, with the chosen hysteresis for Alarm 2 (Setpoint 4) now outside the band.

5. "ALC.5=0" turns the Alarm 2 (Setpoint 4) open-collector output ON when Setpoint 1 is active.
"ALC.5=1" turns it OFF.
6. "ALC.6=0" compares the Alarm 2 (Setpoint 4) level to the UNFILTERED measurements.
"ALC.6=1" compares the Alarm 2 (Setpoint 4) level to the FILTERED measurements.

7. "ALC.7=0" ENABLES both Alarms 1 and 2 (Setpoints 3 and 4) action and LEDs.
 "ALC.7=1" DISABLES both Alarms 1 and 2 (Setpoints 3 and 4) action and LEDs.
8. "ALC.8=0" DISABLES Alarm reset at the P2-11 connector.
 "ALC.8=1" ENABLES Alarm reset at the P2-11 connector.

Press the 'MENU' button to store any changes and advance to "AL FNC" (Alarm Function).

10.6 SELECTING "AL FNC" ALARM FUNCTION FEATURES

This byte allows you to select independent or ganged operation for "SP 3" and "SP 4", and whether or not they should latch once triggered.

1. "ALF.1=0" makes Alarm 1 (Setpoint 3) INDEPENDENT, with a level equal to the value inserted for Setpoint 3.
 "ALF.1=1" assigns Setpoint 3 ("SP 3") to Setpoint 1 ("SP 1"), placing it ABOVE Setpoint 1 ("SP 1") by the amount entered for Setpoint 3 ("SP 3").
 "ALF.1=2" places "SP 3" BELOW "SP 1" by the amount entered for "SP 3".
 "ALF.1=3" places "SP 3" ON BOTH SIDES OF "SP 1" by the amount entered for "SP 3".
2. "ALF.2=0" makes Alarm 1 (Setpoint 3) a NON-LATCHING Alarm.
 "ALF.2=1" makes Alarm 1 (Setpoint 3) LATCHING. This means that once Alarm 1 (Setpoint 3) is triggered it will remain active until it is reset by pressing the 'RESET' button one time or by grounding P2-11 when configuration bit "ALC.8=1" is set. Reset can also be accomplished via the optional RS-232 or RS-485 serial communication board.
3. "ALF.3=0" makes "SP 4" INDEPENDENT, with a level equal to the value inserted for "SP 4".
 "ALF.3=1" assigns "SP 4" to "SP 2", placing it ABOVE "SP 2" by the amount entered for "SP 4".
 "ALF.3=2" places "SP 4" BELOW "SP 2" by the amount entered for "SP 4".
 "ALF.3=3" places "SP 4" ON BOTH SIDES OF "SP 2" by the amount entered for "SP 4".

4. "ALF.4=0" makes Alarm 2 (Setpoint 4) a NON-LATCHING Alarm.
- "ALF.4=1" makes Alarm 2 (Setpoint 4) LATCHING. This means that once Alarm 2 (Setpoint 4) is triggered it will remain active until it is reset by pressing the 'RESET' button one time or by grounding P2-11 when configuration bit "ALC.8=1" is set. Reset can also be accomplished via the optional RS-232 or RS-485 serial communication board.

Press the 'MENU' button to store any changes and advance to "AL RDG" (Alarm Reading).

10.7 "AL RDG": ALARM READINGS-SELECT DELAY IN ALARM ACTION

This byte allows you to select the number of input readings required to trigger Alarm 1 (Setpoint 3) and Alarm 2 (Setpoint 4) action.

When "AL RDG" is displayed, press the 'MIN' button to see two 2-digit numbers, with the first one flashing, indicating that you can reset the delay for SP3 by pressing the 'MAX' button.

After choosing "SP 3" delay, press the 'MIN' button and select the delay for "SP 4" by pressing the 'MAX' button.

Store your selections or changes by pressing the 'MENU' button and advance to "SP DB" (Setpoint Deadband).

10.8 "SP DB": SELECT "SP 1" AND "SP 2" DEADBAND (HYSTERESIS)

The deadband (hysteresis) for Setpoint 1 ("SP 1") and Setpoint 2 ("SP 2") is displayed with the same decimal point location as chosen for run mode.

This selected hysteresis value is EVENLY SPLIT on both sides of the levels chosen for "SP 1" and "SP 2".

View the value by pressing the 'MIN' button, reset by pressing the 'MAX' button, and store by pressing the 'MENU' button. Advance to "AL DB" (Alarm Deadband).

10.9 "AL DB": SELECT ALARM 1 ("SP 3") AND ALARM 2 ("SP 4") DEADBAND (HYSTERESIS)

This selected deadband (hysteresis) for Alarm 1 ("SP 3") and Alarm 2 ("SP 4") is placed on the INACTIVE side of the selected levels. This results in immediate action (if zero (0) delay is selected in "AL RDG") when an alarm limit is exceeded, but defers recovery when the input returns to pre-alarm levels.

Press the 'MIN' button to view the values, change the values of each flashing digit by pressing the 'MAX' button, store any changes by pressing the 'MENU' button. Advance to "OUT.CNF" (Output Configuration).

10.10 "OUT.CNF": CONTROL FLASHING OF THE DISPLAY

You may wish to bring abnormal conditions to immediate attention by causing the display to flash.

Press the 'MIN' button to see "OUT.6".

Press the 'MAX' button to select "0", "1", "2", "3", "4", or "5".

"OUT.6=0" disables display flashing.

"OUT.6=1" flashes the display if SP1 is active.

"OUT.6=2" flashes the display if SP2 is active.

"OUT.6=3" flashes the display if SP3 is active.

"OUT.6=4" flashes the display if SP4 is active.

"OUT.6=5" flashes the display if any SP is active.

Save your choice or changes by pressing the 'MENU' button and the meter will momentarily display "STORED", then "RUN" and proceed with normal operation (go into run mode).

10.11 ENTERING SETPOINT LEVELS (IN RUN MODE)

When you have completed selecting the setpoint(s) (and other features), the last press of the 'MENU' button stores any changes and the meter will automatically return to the run mode (the display will momentarily display "RESET2"). The stored values are placed into operation, and the meter proceeds with normal measurements.

Now you can view and reset all four setpoint levels.

1. Press the 'SETPTS' button. The meter now starts its setpoint display cycle; every 15 seconds, the display flashes the SP number, and then displays the value of that setpoint, with a flashing left-hand digit.
2. You can restart the time-out of any of these display intervals by pressing the 'MIN' button (to shift the flashing [alterable] digit position), or by pressing the 'MAX' button (to increment the value of that digit).
3. When you change the value of any setpoint and then decide to revert to the original value instead, just press the 'RESET' button or allow the display to return to "RUN" at the end of its cycle. The meter does not store a new value for the setpoint in either case.
4. To save a newly-entered setpoint value, press the 'SETPTS' button again.
5. You may return to viewing the measurements by pressing the 'RESET' button or repeatedly pressing the 'SETPTS' button (or by letting the meter complete its setpoint display cycle).

This page is intentionally left blank

11. Peak and Valley Readings

The meter examines every new reading to see if it is greater than the stored PEAK or less than the stored VALLEY readings.

If you have unlocked access to these values with “L1C.5=0” and “L1C.6=0” (part of the first lockout byte “L1 CNF”), you can view the PEAK (“HI RDG”) by pressing the ‘MAX’ button, or the VALLEY (“LO RDG”) by pressing the ‘MIN’ button while in the run mode.

Selection of either PEAK or VALLEY causes the display to flash giving the indication that it is NOT the current measurement value. If the meter measures a more extreme value while displaying the PEAK or VALLEY measurement, the new value will immediately replace the old.

Unlike the setpoint display, there is no time out period. Press the ‘SETPTS’ button or ‘MENU’ button to return to current-value display WITHOUT resetting the PEAK or VALLEY memory.

Press the ‘RESET’ button to return to run mode and start a new PEAK/VALLEY measurement period.

The BCD option can be programmed to read the PEAK (but not the VALLEY) instead of the current measurement (refer to Section 13).

Both PEAK and VALLEY readings (and/or a PEAK/VALLEY status summary character) can be transmitted by the RS-232 or RS-422/485 digital communications (refer to Section 15).

The PEAK or VALLEY value can be transmitted via the optional analog output board (refer to Section 12).

This page is intentionally left blank

12. Analog Output Option

If you received your meter with the optional analog board installed, you should not have to enter the trim data as described in Section 12.5.

Your meter converts display readings into an independently-scaled-and-offset isolated voltage and/or current analog output. Isolation is accomplished via opto-isolators on the board. Your meter has the capability of transmitting SIMULTANEOUS voltage and current outputs although when this is done, the current analog output is not as accurate.

12.1 FEATURES OVERVIEW

1. Precise analog levels are generated from digital code using a proprietary ASIC chip.
2. Voltage (to 10 V) is available at the same time as current (to 22 mA), but the total current drawn should not exceed 24 mA.
3. Load resistance for the voltage output can be as low as 500 ohms (20 mA at 10 V out) when current output is not used.
4. Loop resistance for the current output can be as high as 600 ohms (12 volts compliance) with negligible current from the voltage output.
5. Both outputs are galvanically isolated from both power and measurement circuits of the meter: 354 V per IEC spacing, 500 V test.
6. Precision calibration is applied by the meter to either the voltage output or the current output (but not to both simultaneously). When both outputs are used simultaneously, the non-calibrated output is stable but does require external adjustment if fine-trimming is required.
7. Independent, 15-bit resolution OuTput SCale and Offset (OT.SC.OF) can convert a wide range of meter readings to the desired current or voltage output span.

8. The output resolution permits good accuracy for turndown ratios (offset/span) as high as 100:1.
9. 50° to 104°F (10° to 40°C) accuracy within 0.1% after installation calibration.
10. 10% to 90% step response time is 50 milliseconds (plus filter delay, if any, programmed for the analog output).
11. Configurable so that output will track the PEAK or VALLEY measurement.

12.2 UNLOCKING

1. Press the 'MENU' button until "L3 CNF" is displayed, then press the 'MIN' button until "L3C.7" is displayed.
2. Press the 'MAX' button (if required) to set "L3C.7=0", unlocking the choice of current or voltage as the calibrated output.
3. Press the 'MIN' button (and the 'MAX' button if required) to set "L3C.8=0", unlocking OT.SC.OF.
4. Press the 'MENU' button to store these choices.
5. If your analog board is NEWLY INSTALLED, you will need to enter the four trimming constants (refer to the one-time only procedure in Section 12.5). To unlock this feature, press the 'MIN' button and then the 'MAX' button to set "L4C.6=0" and store by pressing the 'MENU' button.

12.3 "OUT.CNF": CONFIGURING THE OUTPUT

1. Press the 'MENU' button until "OUT.CNF" is displayed, then press the 'MIN' button to display "OUT.1=0" or "OUT.1=1".
2. Press the 'MAX' button to set "OUT.1=1" if you wish the analog output to be driven at once when you return to run mode. (You can leave this as "OUT.1=0" and complete all the other programming if you wish to activate the analog output at a later time by returning to this configuration bit).

3. Press the 'MIN' button (and the 'MAX' button if required) and set "OUT.2=0" for calibrated VOLT output (0-1 V, 0-5 V, 1-5 V, or 0-10 V) or "OUT.2=1" for calibrated CURRENT (0-20mA or 4-20 mA) output.
4. Press the 'MENU' button to store these choices (the rest of the "OUT.CNF" byte controls BCD and display-flashing features).

After pressing the 'MENU' button again, you advance to "OT.SC.OF" (Output Scale and Offset).

12.4 "OT.SC.OF": SETTING OUTPUT SCALE AND OFFSET

Any two data points can be used here: a data point is specified by a value of the display ("READ") and the desired output ("OUTPT") for that display.

1. Press the 'MIN' button to see "READ1" and then use the 'MIN' and 'MAX' buttons to enter a small display value, for example, "000.000", where the center decimal point position is used as an example.
2. Store this value by pressing the 'MENU' button and then you see "OUTPT1". Use the 'MIN' and 'MAX' buttons to specify the desired output value, for example, "04.0000" if current calibration had been selected ("OUT.2=1"), or "00.0000" for voltage.
3. Store this value by pressing the 'MENU' button and then advance to "READ2". Use the 'MIN' and 'MAX' buttons to enter a large display value, for example, "123.456", for the display that you want the analog output at full scale.
4. Store this value by pressing the 'MENU' button and then advance to "OUTPT2". Use the 'MIN' and 'MAX' buttons to enter the desired output for the display value in step 3. For example, enter "20.0000" for calibrated current or "10.0000" for calibrated voltage.
5. Press the 'MENU' button to store. Press the 'RESET' button two times to return to run mode and check calibration points, unless your analog output board is newly installed; in this case, follow Section 12.5.

12.5 BOARD INSTALLATION; ENTERING THE TRIM DATA

To precisely calibrate your analog output board with your meter, each analog output board has been supplied with voltage and current zero trim values printed on the board. "CAL VZ" is for the voltage output and "CALmAZ" is for the current output.

Similarly, the fine trim for output gain is "CAL VS" for the voltage output and "CALmAS" for the current output.

These 4 data points are obtained from the factory calibration of each analog output board and are inscribed on the top edge of each board, as shown in Figure 12-1.

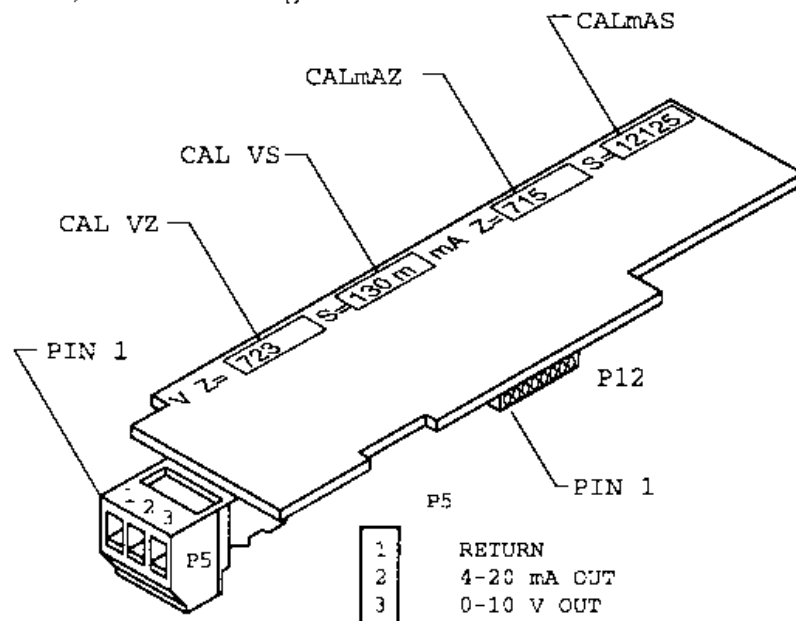

Figure 12-1. Analog Option Board

If you are installing an analog output board, follow this "one time only" procedure:

1. Write down the four (4) numbers inscribed on the top edge of your analog output board below:

CAL VZ = _____

CAL VS = _____

CALmAZ = _____

CALmAS = _____

2. "Reveal the main board" and install the analog output board using the procedures outlined in Section 5.2.
3. Attach connector wires, insert connectors, and apply power to the meter as described in Section 5.3.
4. If not already unlocked, press the 'MENU' button until "L4 CNF" is displayed and press the 'MIN' button six times. Now press the 'MAX' button to set "L4C.6=0".
5. Press the 'MENU' button to store and advance to "CAL VZ". Use the 'MIN' and 'MAX' buttons to enter the value (recorded from the edge of the board).
6. Press the 'MENU' button to store and advance to "CAL VS". Use the 'MIN' and 'MAX' buttons to enter the value.
7. Repeat for "CALmAZ".
8. Repeat for "CALmAS".
9. Press the 'MENU' button to store your entries and then you will see "C.JUN.OF". Press the 'RESET' button two times and you will see "RESET2", followed by "RUN". Verify your calibration points for the analog output.

12.6 FILTER CONFIGURATION "FIL.CNF" VALUE TO BE TRANSMITTED ON ANALOG OUTPUT

1. Press the 'MENU' button until the display shows "FIL.CNF".
2. Press the 'MAX' button until the display shows "FIL.3=0", "FIL.3=1", "FIL.3=2", or "FIL.3=3".
3. "FIL.3=0" Transmits the unfiltered value of your signal input.
"FIL.3=1" Transmits the filtered value of your signal input.
"FIL.3=2" Transmits the recorded PEAK ("HI RDG") value(s).
"FIL.3=3" Transmits the recorded VALLEY ("LO RDG") value(s).
4. Press the 'MENU' button to store your selection or changes and the meter will advance to "FIL TI" (Filter Time Constant). Press the 'RESET' button two times to return to the run mode.

This page is intentionally left blank

13. BCD Option

13.1 FEATURES OVERVIEW

1. 6 BCD digits (24 lines plus 1 polarity, 3 decimal-point location code, 1 overflow, 1 timing, 1 control, 4 card address, and 3 isolation power lines).
2. Furnished 40-line mass-terminated connector: pin compatibility with 50-pin BCD cable assignments.
3. Can be jumpered for internal, non-isolated drive or external power with isolation (354 V per IEC spacing, 500 V test).
4. Upper 3 BCD digits can be multiplexed onto lower 3 BCD lines for 3 digits at a time readout.
5. All outputs tri-state, TTL/CMOS compatible, 10 LSTTL loads.
6. Data always valid (stored, buffered).
7. Selectable 4-line card address (with internal pull-ups) or single-line activation.

Figure 13-1 shows the rear of the meter case with the 40-line edge connector highlighted and the upper and lower pin assignments.

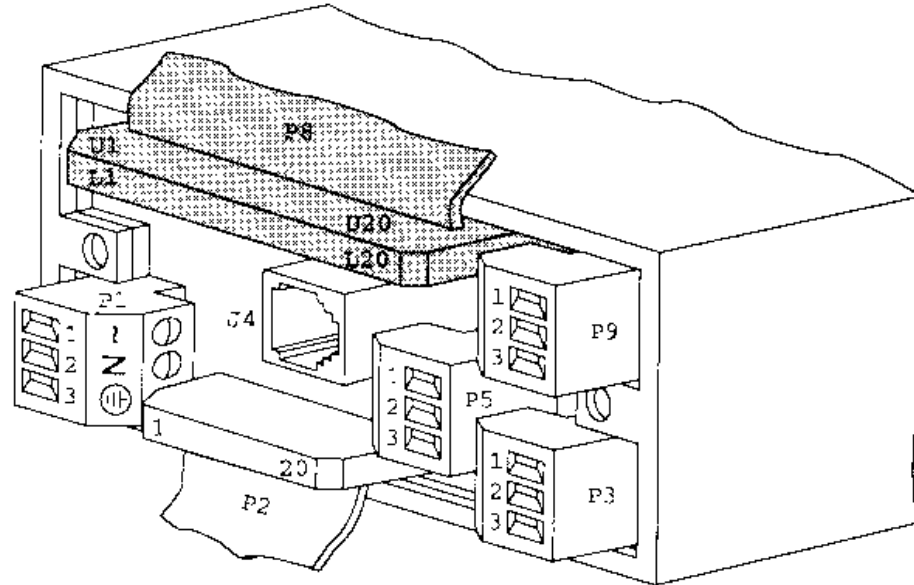

P8			
BCD 400K	L1	U1	BCD 800K
BCD 100K	L2	U2	BCD 200K
ISO GND	L3	U3	SPARE
BCD 40K	L4	U4	BCD 80K
BCD 10K	L5	U5	BCD 20K
BCD 4K	L6	U6	BCD 8K
BCD 1K	L7	U7	BCD 2K
D.P. 2	L8	U8	D.P. 4
BCD 400	L9	U9	BCD 800
BCD 100	L10	U10	BCD 200
BCD 40	L11	U11	BCD 80
BCD 10	L12	U12	BCD 20
BCD 4	L13	U13	BCD 8
BCD 1	L14	U14	BCD 2
ISO GND	L15	U15	D.P. 1
DATA READY	L16	U16	<u>POLARITY</u>
ISO V+	L17	U17	HOLD
<u>SPARE</u>	L18	U18	<u>OVERFLOW</u>
<u>ADDRESS B4</u>	L19	U19	<u>ADDRESS B8</u>
<u>ADDRESS B1</u>	L20	U20	<u>ADDRESS B2</u>

Figure 13-1. BCD 40-Pin Cable Connector (P8)

Figure 13-2 shows the board connections and pin designators. The locations of the jumpers are also shown.

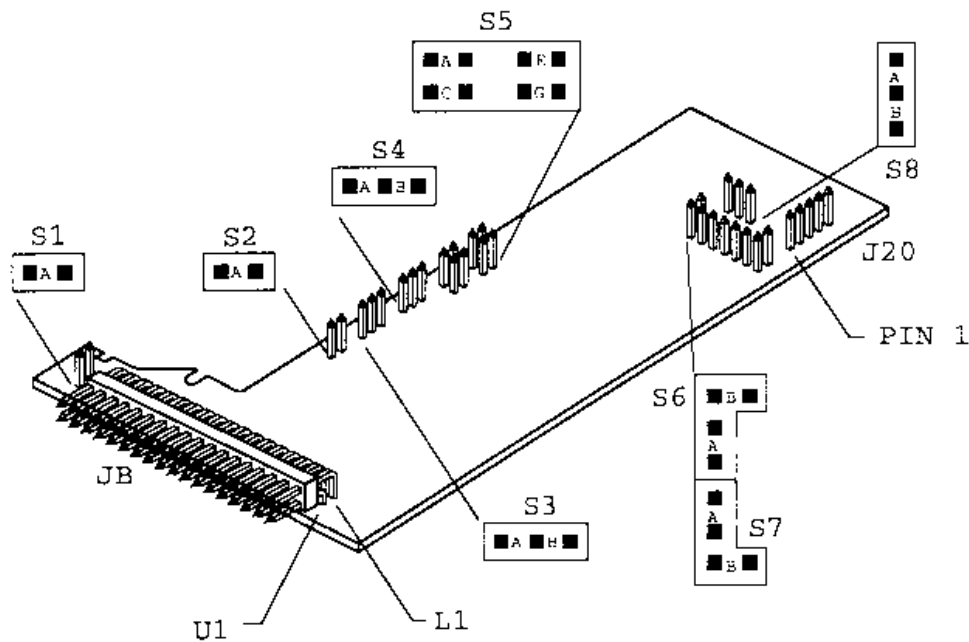

Figure 13-2. BCD Option Board

13.2 BCD CARD JUMPER TABLE

JUMPER	WHEN USED
S1A	Brings OVERFLOW signal to P8-U18
S2A	Insert for 3-digit multiplex Remove for 6-digit readout
S3A	Insert for 3-digit multiplex or one-line card-address enable
S3B	OR 4-line card-address enable
S4A	Insert for 3-digit multiplex
S4B	OR Insert for 6-digit readout
S5A	P8-U20 must be low to enable card Remove for high or open enable

JUMPER	WHEN USED
S5C	P8-L20 must be low to enable card Remove for high or open enable
S5E	P8-U19 must be low to enable card Remove for high or open enable
S5G	P8-L19 must be low to enable card Remove for high or open enable
S6A, S6B, S7A, S7B	Install for internal power Remove for isolated power
S8A	Output data is negative-true OR
S8B	Output data is positive-true

13.3 INTERCONNECT BOARD

For mechanical support and electrical interconnection, each BCD board is shipped with a small 5-pin INTERCONNECT board. Insert onto the main board pins immediately behind the right-hand side of the display board. The BCD board itself (component side down) is then plugged into the interconnect board at J20, with the PCB connection fingers protruding from the case rear. For assembly detail, refer to Figure 5-5 (in Section 5).

13.4 50-LINE CABLE COMPATIBILITY

The 40 lines of the BCD connector are compatible with lines 9 through 48 of some 50-line busses (left-most 8 and right-most 2 are not used by this BCD option).

13.5 SELECTING THE SOURCE OF BCD DATA: "OUT.CNF"

If "L3C.7=0" has been selected to unlock the OUTPUT CoNfiguration byte, set "OUT.3=1" to send data to this BCD board. "OUT.4=0" selects that data as the DISPLAYED (current) measurement value. "OUT.4=1" sends the PEAK (HI) value to the BCD. Save your selection by pressing the 'MENU' button.

13.6 HOLD CONTROL

P8-U17 is the $\overline{\text{HOLD}}$ line, referenced to the same ground as the BCD outputs (on P8-L15 and P8-L3). Pulling this line low freezes the BCD outputs (useful for a slow reading device or asymmetric cable delays).

When released, all 6 digits of the BCD data are updated together.

13.7 DATA READY TIMING PULSES

The tri-state BCD outputs are always valid (to within a few nanoseconds; a single update pulse controls all the digits).

To generate a timing marker, P8-L16, $\overline{\text{DATA READY}}$, goes active low for approximately 200 microseconds at the time of each BCD update. The polarity of this line is NOT CHANGED by S8, the data polarity control jumper.

13.8 BRINGING OUT THE BCD OVERFLOW LINE

P8-U18 can be used for BCD OVERFLOW by inserting jumper S1A. If this line is used for another purpose by some other equipment on the BCD bus, remove this jumper.

13.9 3 DIGIT AT A TIME MULTIPLEX

When jumpers S2A, S3A, and S4A are used, P8-L20 and S5C control when the upper 3 digits of the 6-digit BCD value appear on the output line (P8-U9 through P8-L14).

With jumper S5C, a LOW level on P8-L20 activates those upper 3 digit outputs; a high or open level disables those digits.

With jumper S5C removed, a high or open level on P8-L20 enables those upper 3 digits and a low level disables them.

When the upper 3 digits are NOT enabled, the lower 3 digits can be enabled in just the same way by jumper S5A and P8-U20, and they now appear on the same 12 lines.

13.10 6 DIGIT AT A TIME CARD ADDRESS

Jumpers S2A and S4A are removed for full parallel (6-digit output).

If jumper S3A is installed, the outputs are enabled by line P8-L20 ALONE: a low level enables the outputs when jumper S5C is installed, and a high or open level does the job if S5C is removed.

When jumper S3A is removed, the outputs are enabled only when the selected 4-line address is applied to P8-U19, L19, U20 and L20. Each

of these four is exclusive-OR'd with its jumper, and the following four outputs are AND'd to create a 1 of 16 enable code.

If jumper S5A is installed, P8-U20 must be LOW to enable the card (BIT 2).

If jumper S5C is installed, P8-L20 must be LOW to enable the card (BIT 1).

If jumper S5E is installed, P8-U19 must be LOW to enable the card (BIT 8).

If jumper S5G is installed, P8-L19 must be LOW to complete enabling the card outputs (BIT 4).

BINARY BIT	1	2	4	8		1	2	4	8
JUMPER S5-	C	A	G	E		C	A	G	E
00	X	X	X	X	08	X	X	X	
01		X	X	X	09		X	X	
02	X		X	X	10	X		X	
03			X	X	11			X	
04	X	X		X	12	X	X		
05		X		X	13		X		
06	X			X	14	X			
07				X	15				

Figure 13-3. Address Programming Chart for 4-line Address

NOTE: "X" in chart indicates jumper that must be installed.

EXAMPLE: For a positive true address of 03, install jumpers S5-G and S5-E.

If any of these jumpers are removed, the corresponding line must go HIGH or OPEN to assist the card enable; if all four jumpers are missing, for example, the card outputs are enabled ONLY when all four lines are HIGH or OPEN, a ground on any of the four input lines causes the outputs to go to the high impedance state.

13.11 SELECT DATA POLARITY: JUMPER S8

Inserting the jumper in S8B (the usual shipping position) makes the output data (including decimal point code) positive-true.

Placing the jumper in S8A converts the data to negative-true.

13.12 DECIMAL POINT ADDRESS CODE

P8-U15, P8-L8 and P8-U8 output a 3-bit positive-true binary code for the location of the decimal point: "001" for the extreme right position and "110" for the extreme left position (just to the right of the left-hand digit).

Panel-mounted printers, however, may require an inverted/shifted decimal point code. You can create this by setting "OUT.5=1" in the "OUT.CNF" byte (unlocked by setting "LIC.7=0"), rather than the normal "OUT.5=0".

13.13 APPLYING NON-ISOLATED/ISOLATED POWER

Non-isolated power from the meter is connected to this board by inserting jumpers S6A, S6B, S7A, and S7B (bridging the isolation separation distance on the board). Current drawn is less than 10 mA.

To isolate these outputs from the other meter circuits, remove the four jumpers described earlier, and connect an external, nominal 5 V supply to P8-L17, with its ground return connected to P8-L15.

13.14 DRIVING A PRINTER

Direct connection of the 24 BCD lines and the 3 decimal point address lines is all that is needed for positive-true printers that accept a binary-coded decimal point address (which do not print the decimal point).

If your printer has more than 6 digits, tie the unused inputs to ground or V+ or leave open (whichever produces blanks in those locations).

For negative-true decimal point addresses, found in some panel-mounted printers, set "OUT.5=1" (part of menu item "OUT.CNF", unlocked by "LIC.7=0").

This page is intentionally left blank

14. Relay Option

14.1 FEATURES OVERVIEW

- 1. Two isolated (354 V per IEC spacing, 500 V test) 7-ampere Form C electro-mechanical relays are provided on a small vertical board that plugs into J10 on the main board.
- 2. Each relay has its 3-pin screw-terminal connector protruding from the rear of the case. Each connector is keyed to prevent inadvertent insertion of the power screw terminal connector.
- 3. Clamp diodes to the V+ supply limit coil turn-off spikes.
- 4. 200 ohm, 2500pf snubbers are provided for each normally open contact.
- 5. Relay 1 can be driven by either SP1 or SP3.
- 6. Relay 2 can be driven by either SP2 or SP4.

Figure 14-1 shows the board connections and jumper locations.

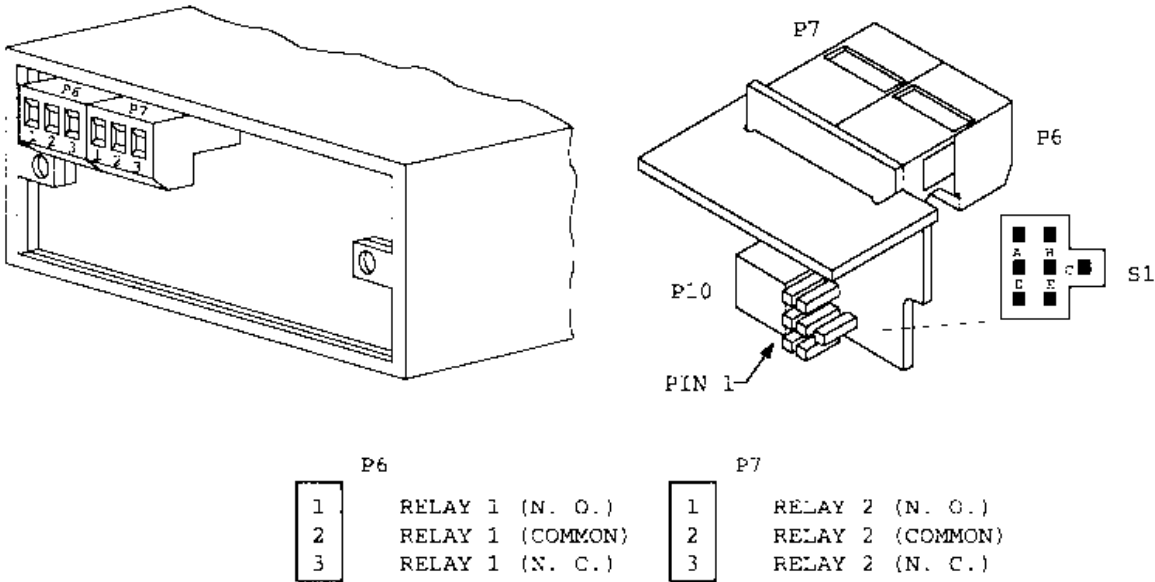

Figure 14-1. Relay Option Board

14.2 RELAY BOARD JUMPER TABLE

JUMPER	FUNCTION
<u>S1A</u> *	Drives Relay 1 from SP3
S1B	not used
S1C	Drives Relay 2 from SP2
S1D	Drives Relay 1 from SP1
<u>S1E</u> *	Drives Relay 2 from SP4

* Factory preset jumper locations

Notes:

15. RS-232 or RS-485 Option Board

15.1 FEATURES OVERVIEW

1. When you order either option board, you will also receive 2 software diskettes (one 5-1/4" and one 3-1/2"), a complete configurations setup program, and a six foot communications cable that plugs into J4. Optional female 9-pin and 25-pin "D" computer connector-adapters are offered for either RS-232 or RS-422/485 hookup.
2. The communications board you ordered, plugs into the main board socket (P11 connects into J11 next to the transformer) with the 6-pin telephone socket. J4 is then protruding out of the rear of the case.
3. Install, run, establish communication and meter setup information are described in Section 15.3; screen error messages are described in Section 15.4 and a sample basic program to read the meter information to your screen is described in Section 15.5.
4. There are no jumpers on the RS-232 card (all software controlled with or without button programming).
5. Only 3 RS-422/485 jumpers (half/full duplex and impedance-matching resistors).
6. Choose baud rate from 300 to 19200. Standard factory setting is 9600.
7. Wide choice of commands and message formats available.

Figure 15-1 gives the board connections and pin designators for RS-232.

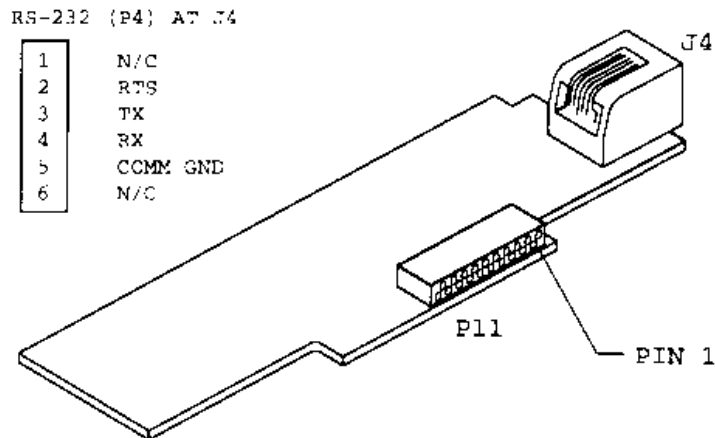

Figure 15-1. RS-232 Option Board

Figure 15-2 shows board connections and pin designators for RS-485.

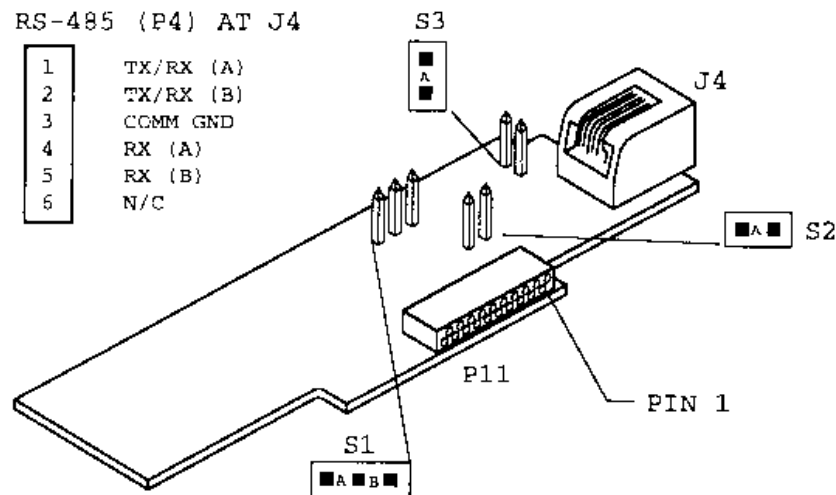

Figure 15-2. RS-485 Option Board

15.2 FRONT-PANEL PUSHBUTTON CONFIGURATION

Setup configuration can be accomplished via the front panel buttons or via your computer if you use the configuration setup program. If you are going to use a computer, your choices include "AUTO SET" or "MANUAL SET" for establishing communication with your meter. "AUTO SET" cycles through the possible combinations of baud rate, parity and stop bits to find a match for your meter settings. For faster action, you may enter the values for your meter via "MANUAL SET".

If your meter communications settings are unknown or need changing, you can insert the factory-set values with the front panel

buttons (or, after communications has been established, from your keyboard).

1. Unlock the communications bits by setting "L4C.1=0", "L4C.2=0", "L4C.3=0", "L4C.4=0" and "L4C.5=0".
2. Press the 'MENU' button until "BAUD" is displayed, then press the 'MAX' button until the baud rate you require is displayed. Press the 'MENU' button to store this choice and your meter will display "SERCNF".
3. Press the 'MIN' button until you see the display show "SER.1=0" for no parity, "SER.1=1" for odd parity, or "SER.1=2" for even parity. Press the 'MAX' button to select the parity required for your system. Once you have done that, press the 'MIN' button and advance to "SER.2=0" or "SER.2=1".
4. By pressing the 'MAX' button you can select the "SER.2" value. Setting "SER.2=0" picks the value to one stop bit; "SER.2=1" selects two stop bits. Select "SER.2=0".
5. Pressing the 'MENU' button stores these choices and then the meter advances to "ADDRES". Use the 'MAX' button to set to "001" (unless your meter is one of several on an RS-485 bus, in which case you must give a different address to each device and use those addresses when communicating from your computer).
6. Press the 'MENU' button again and press the 'RESET' button two times to return to the run mode. The remaining communications format and options are set from your keyboard.

15.3 INSTRUCTIONS FOR USING THE SETUP PROGRAM

1. Requirement: 640 K or more RAM and DOS 3.1 or higher.
2. Insert appropriate size diskette into your computer drive.
3. If you are using an LCD screen computer, at the DOS prompt "A:\>", "B:\>", or "C:\>", type "MODE MONO" (or, for some DOS version, type "MODE BW80"), then press 'ENTER'.
4. If loading from the floppy (rather than moving the program onto your hard disk, if any) with a CRT computer, at the DOS prompt "A:\>" or "B:\>", type "INF" and then press 'ENTER'.

5. To copy the program from floppy disk to the hard drive, at the DOS prompt "C:\>", type "MD INF" and press 'ENTER'. Now type "CD\INF" and press 'ENTER' again. Type "COPY A:*.*)" (or "COPY B:*.*)" for the other floppy drive) and press 'ENTER'.

To start the program, type "INF" and press 'ENTER'.

Your screen now displays a WELCOME message and the program begins to load into your RAM. (**NOTE:** Loading time can vary from seconds to 3 minutes depending on computer speed and the drive chosen; hard disk drives are the fastest).

When loading is completed, the COPYRIGHT screen appears. Press 'ESC' to go to the top level screen.

<p style="text-align:center"><u>TOP-LEVEL MENU</u></p> <p style="text-align:center">GUIDE TO MENUS AND KEYSTROKES</p> <p style="text-align:center">SERIAL COMMUNICATIONS MENU</p> <p style="text-align:center">METER SETUP MENU</p> <p style="text-align:center">QUIT</p>

The GUIDE selection shows you all the different menus and keystrokes used in the program.

The SERIAL COMMUNICATIONS MENU is to be used before the SETUP MENU, to identify your meter, initialize the communication parameters, and establish communication with the meter.

The METER SETUP MENU is used AFTER communication with the meter is established and will lead you through the selection of all the meter features to specialize it to your application.

<p><i>WARNING: IF YOU ATTEMPT TO SEND THE METER SETUP DATA BEFORE ESTABLISHING COMMUNICATIONS, YOUR COMPUTER MAY LOCK UP (AND THEN YOU MUST START FROM THE BEGINNING BY REBOOTING THE SOFTWARE).</i></p>
--

After selecting SERIAL COMMUNICATIONS MENU (by moving the highlight to this line with your arrow keys and then pressing 'ENTER'), the screen shows:

```

COMMUNICATION PROTOCOL

RS-232 PROTOCOL

RS-485 PROTOCOL
  
```

Use your up or down arrow key, highlight your choice and press 'ENTER'. Now the screen shows:

```

SET RSxxx

AUTO SET

MANUAL SET
  
```

(where xxx is either 232 or 485).

If you choose:

AUTO SET with RS-232: the program will cycle through the possible choices of baud rate, parity, stop bits and recognition symbols in trying to talk to the meter.

NOTE: This takes some time, so be patient!

AUTO SET with RS-485: the only item necessary is the meter's address.

If you have selected MANUAL SET and pressed 'ENTER', the screen shows:

```

RS-232 CONFIGURATION
COMMUNICATION PORT:      1
BAUD RATE:               9600
PARITY:                  ODD
STOP BIT(S):             ONE
TRANSMIT/RECEIVE
SWITCHING DELAY:        100 ms
  
```

OR

RS-485 CONFIGURATION	
METER ADDRESS:	1
COMMUNICATION PORT:	1
BAUD RATE	9600
PARITY:	ODD
STOP BIT(S):	ONE
TRANSMIT/RECEIVE	
SWITCHING DELAY	100 ms

The above values are the factory settings. If your meter differs, enter its values on this screen by moving the highlight with the arrow keys, changing values with the number keys, and storing each entry by pressing 'ENTER'.

After pressing 'ENTER', the program starts to establish communications with your meter.

When the program successfully establishes communication, your screen shows:

COMMUNICATION ESTABLISHED PLEASE PRESS 'ESC' TO CONTINUE

If, however, an error message is displayed instead, refer to Section 15.4 to interpret the message and start over again after correcting the error.

When you press 'ESC', the TOP LEVEL MENU is displayed again. Highlight "METER SETUP MENU" and press 'ENTER'.

You will now be guided through the different meter configuration selections required for your application such as "INPUT", "INPUT TYPE", etc.

After completing your selections, select 'SEND TO (THE METER)' on your screen and press 'ENTER'. The program now transmits the proper codes to load the meter's non-volatile memory with your choices.

If there is an error, you will be prompted with the appropriate flashing error message.

If the program completes successfully, you will see:

COMMUNICATION COMPLETED
PLEASE PRESS 'ESC' TO CONTINUE

You may now start to program another meter, make changes, or select "QUIT" from the TOP LEVEL MENU, and then press 'ENTER'.

15.4 SCREEN ERROR MESSAGES

MESSAGE	PROBABLE SOURCE
COMMUNICATION ERROR:	No meter response, so: <ol style="list-style-type: none"> 1. Hardware: bad connections, no meter power, bad cable, boards not inserted correctly, defective boards, etc. 2. Baud rate or stop bits mismatched between computer and meter. 3. Computer communications port not correct. 4. RS-485 meter address does not match.
PARITY ERROR:	Meter setting and computer selection do not agree.
COMMAND ERROR:	Command character wrong.
FORMAT ERROR:	Transmitted characters do not have proper length or are not valid characters.
CHECKSUM ERROR:	Noise causing errors in received characters.

continued next page

MESSAGE	PROBABLE SOURCE
EEPROM LOCKOUT:	Meter not storing data: jumper S3A on main board is missing, or pin 10 on the meter's P2 rear connector is grounded.
DECIMAL POINT FRACTION TOO LARGE:	Selected decimal point location is too far to the left to permit READING OFFSET or SETPT value storage. Everything is stored here except the decimal point.

NOTE: "ECHO" command mode is recommended for all communications since it always produces a response for successful communication. Otherwise, the program cannot warn you with a COMMUNICATION ERROR message.

15.5 SERIAL COMMUNICATIONS SAMPLE PROGRAM

The following sample program will allow you to send a request for information to the meter and receive a response.

NOTE: The codes in this sample program are found in the serial communications operators guide.

15.5.1 PROGRAM OBJECTIVES

1. Clear screen
2. Print "Enter a Command>"
3. Accept "X01" (requests unfiltered meter reading)
4. Accept "X02" (requests PEAK meter reading)
5. Accept "X03" (requests VALLEY meter reading)
6. Accept "X04" (requests filtered meter reading)
7. Accept any other command code and suffix, ("ccc") from list in the Serial Communications Operator's guide.
8. Screen echoes the chosen command
9. Computer sends request to meter

10. Stall for 0.5 seconds, then look for response
11. Put watchdog message on screen if no response in 10 seconds
12. Print meter response on screen
13. User selects Quit or more commands.

15.5.2 CODE AND [NOTES]

- | | |
|------|--|
| 1000 | CLS [Clear screen command] |
| 1010 | COMMS = "COM1" [Label for communications port COM1] |
| 1020 | BAUD\$ = "9600" [Label for choice of 9600 baud] |
| 1030 | PARITY\$ = "0" [Label for Odd parity] |
| 1040 | STOPBT\$ = "1" [Label for one stop bit] |
| 1050 | CLOSE #1 [Get ready to reopen #1] |
| 1060 | OPEN COMM\$ + BAUD\$ + "," + PARITY\$ + ",7," + "CS,DS,RS" AS #1 [OPENS COM1] |
| 1070 | INPUT "ENTER A COMMAND >",CMD\$
[Prompts and Labels Input] |
| 1080 | IF CMD\$ <>"^AE" THEN CMD\$ = "*" + CMD\$
[Add recognition character unless command is that for setup data] |
| 1090 | PRINT CMD\$ [Screen echoes command] |
| 1100 | PRINT #1, CMD\$ [Send command to meter] |
| 1110 | N = 0 [Initialize watchdog] |
| 1120 | SOUND 32767,27:SOUND 32767,1:
SOUND 32767,1 [Delay 0.5 seconds] |
| 1130 | N = N + 1 [Increment watchdog] |
| 1140 | IF N <> 20 THEN 1180 [Test for timeout] |

continued next page

```
1150 INPUT "NO RESPONSE YET: TYPE 'C' TO
CONTINUE, 'Q' TO QUIT",B$ [10 second timeout]

1160 IF B$ = "Q" THEN 1230 [Exit if desired]

1170 N = 0 [Restart watchdog]

1180 IF LOC(1) = 0 THEN 1120 [Stall until buffer
has contents]

1190 A$ = INPUT$(LOC(1),#1)
[Read and label contents of COM1]

1200 PRINT A$ [Put data onto screen]

1210 INPUT "TYPE 'M' FOR MORE COMMANDS OR
'Q' TO QUIT", B$

1220 IF B$ = 'M' THEN 1070

1230 END
```

16. External Control Lines

P2, the 20-pin connector at the rear of the main board, connects to the setpoint transistor collectors and permits remote control of significant meter features.

The meter case label gives the names (abbreviated functions) of each of the twenty pins of P2, the center-bottom connector. Refer to Figure 16-1.

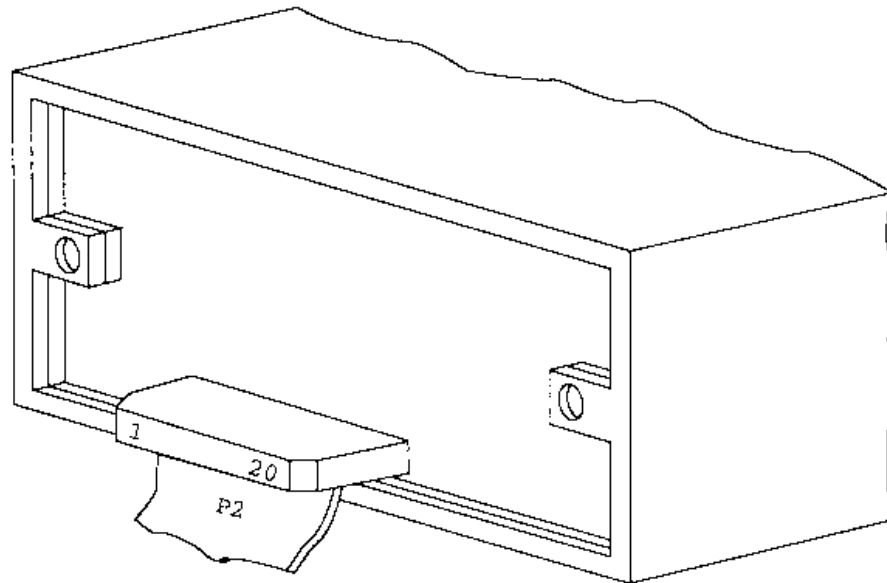

		P2			
TARE (T)	1	2	PEAK (P)		
VALLEY (V)	3	4	SWLIN2		
PEAK/VALLEY OR EXT. RESET	5	6	PUSH TO CAL		
DIG GND	7	8	+5V		
DISPLAY HOLD	9	10{	LOCKOUT EEPROM & MENU PUSH BUTTON		
RESET ALARMS AND/OR PRINT COMMAND	11				
NONSTANDARD TX	13	12	NONSTANDARD RX		
+V EXT	15	14	PUSH TO CAL		
SP2	17	16	SP1		
AL2	19	18	AL1		
		20	GND EXT		

Figure 16-1. Connector Label Detail

16.1 TARE (PIN 1)

Tare is not available for the temperature meters.

16.2 PEAK (PIN 2)

When this is connected to P2-4 by an external switch, the meter displays the stored PEAK (“HI RDG”) value rather than the current reading. The display flashes to distinguish this value.

16.3 VALLEY (PIN 3)

When this is connected to P2-4 by an external switch, the meter displays the stored valley (“LO RDG”) value rather than the current reading. The display flashes to distinguish this value.

16.4 SWLIN2 (PIN 4)

Completes the circuit for any of the above three signals.

16.5 PEAK & VALLEY OR EXTERNAL RESET (PIN 5)

Connecting this to ground (P2-7) when “RDG.7=0” has been programmed causes a “HARD” RESET (when you see “RESET2” on the display). If you set “RDG.7=1”, grounding causes only a PEAK/VALLEY RESET.

16.6 PUSH TO CAL (PIN 6)

Not applicable for temperature meters.

16.7 DIGITAL GROUND (PIN 7)

This is a non-isolated ground to be used for the digital controls provided on this P2 connector.

WARNING: THIS METER GROUND IS NOT ISOLATED FROM THE SIGNAL INPUT AND SHOULD NOT BE CONNECTED TO EXTERNALLY-GROUNDED DEVICES UNLESS ISOLATION IS PROVIDED EITHER AT THE SIGNAL INPUT OR AT THIS EXTERNAL-LOGIC CONNECTION.

16.8 +5 V (PIN 8)

Up to 20 mA is available for driving external devices, but isolation should be provided if there is a possibility of common mode (ground) currents, since this supply is NOT isolated from the signal input.

16.9 DISPLAY HOLD (PIN 9)

Grounding this pin to P2-7 freezes the display value. However, the meter continues to take new samples and update the other outputs, such as Analog Output, BCD, Setpoints/Alarms, and Peak/Valley.

16.10 LOCKOUT EEPROM (AND 'MENU' BUTTON) (PIN 10)

Grounding this pin to P2-7 stops any configuration changes and new storage into the non-volatile memory, and when in run mode does not allow entry into the setup mode when the 'MENU' button is pressed.

16.11 PRINT COMMAND AND/OR RESET OF ALARMS (PIN 11)

Grounding this pin to P2-7 when "BUS.8=1" has been programmed will initiate a meter printout via serial communications in the format previously selected. If "ALC.8=1" it causes the alarm latches to reset.

16.12 NONSTANDARD RX (PIN 12) AND NONSTANDARD TX (PIN 13)

These two pins allow digital communications with the meter using 5 V CMOS logic levels and RS-232 protocols and format. This access is normally reserved for specialized equipment communication in a calibration lab or at the factory.

16.13 PUSH TO CAL (PIN 14)

NOT USED

16.14 +V EXT (PIN 15)

This is the pin on which to bring in isolated external 5 to 30 V to power the snubbing diodes of the four setpoint/alarm open-collector transistors.

16.15 SP1 (PIN 16)

The open-collector of the first setpoint transistor (can carry 150 mA).

16.16 SP2 (PIN 17)

The open-collector of the second setpoint transistor (can carry 150 mA).

16.17 AL1 (PIN 18)

The open-collector of the third setpoint (first alarm) transistor (can carry 150 mA).

16.18 AL2 (PIN 19)

The open-collector of the fourth setpoint (second alarm) transistor (can carry 150 mA).

16.19 GND EXT (PIN 20)

This is the return to the external ground (P2-20) of the external power for the setpoint transistors and snubbing diodes brought in on P2-15, 16, 17, 18 and 19. Figure 16-2 shows an example of a circuit using an external relay with SP1 (Setpoint 1). If a solid state relay is used, delete connection to Pin 15.

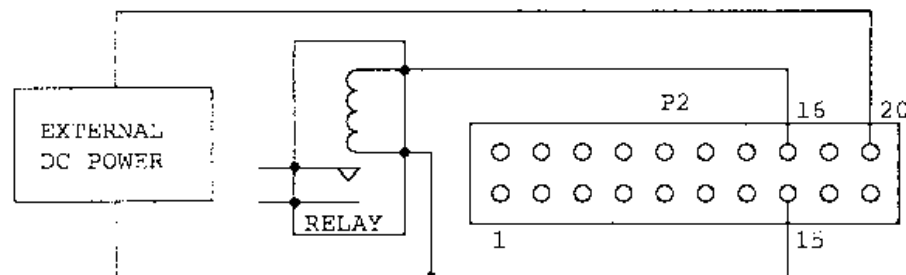

FIGURE 16-2. Connection of External Power for Setpoint Transistors

17. Troubleshooting - Display Messages and Troubleshooting Guide

A flashing alpha-numeric message in the display generally indicates an incorrect combination of jumpers and/or configuration values.

17.1 ERROR MODE MESSAGES

17.1.1 FLASHING "999999" (NUMERICAL OVERFLOW)

The maximum number of counts in the display cannot exceed -99999 or 999999. If, by moving the ACTIVE decimal point one or more places to the left, you cause the display to move beyond the maximum number of counts it is capable of showing (for example, 12345.0 to 12345.00), the display will indicate the overflow by flashing "999999".

17.1.2 FLASHING "ERR 01" (OFFSET OVERFLOW)

When an offset value has been entered and then the ACTIVE decimal point has been moved one or more places to the left, causing the offset display reading to move beyond the maximum number of counts it is capable of showing (for example, 1000.00 to 1000.000), the display will go into offset overflow.

NOTE: The meter will only display 6 digits (999999) maximum.

17.1.3 FLASHING "ERR 02" (SETPOINT OVERFLOW)

After a Setpoint (or Alarm) value has been entered and then the ACTIVE decimal point has been moved one or more places to the left, causing the setpoint display reading to move beyond the number of counts it is capable of showing (for example, setpoint at 100.00 and then a decimal point change to 100.0000), the display will indicate the SETPOINT OVERFLOW by momentarily flashing "ERR 02" before returning to the run mode.

NOTE: The meter will only display 6 digits (999999) maximum.

17.1.4 "NOSTOR" & "STORED" (PROGRAMMING ENTRIES IN EEPROM)

If you are in the configuration mode and you make a CHANGE to any setup parameter (for example, changing "RDG.1 = 1" to "RDG.2 = 0") and press the 'MENU' button, the display will MOMENTARILY flash either "STORED" or "NOSTOR" and then go to the next menu item. If you are in a submenu, this will only occur when you press the 'MENU' button to go to the next menu item.

17.1.5 FLASHING "+OVLD" (POSITIVE INPUT OVERLOAD)

If the input signal exceeds the range selected (for example, 0-100 mV range selected and greater than 110 mV is applied to the input), the display will flash a "+OVLD".

17.1.6 FLASHING "+OPEN" (OPEN SENSOR INDICATION)

Coupled with the proper jumper selection, the display will indicate an open sensor.

17.1.7 FLASHING "-OPEN" (OPEN SENSOR INDICATION)

Coupled with the proper jumper selection, a "-OPEN" indicates the input is below the bottom limit of the range selected.

17.1.8 FLASHING "I OVSC" (INPUT OVERSCALE)

This display occurs when the input scale and/or offset applied to the input signal causes the display to go into a numerical overflow.

17.1.9 FLASHING "R OVSC" (READING OVERSCALE)

This display occurs when the reading scale and/or offset applied to the input signal causes the display to go into a numerical overflow.

17.1.10 FLASHING "CB OVFL" (COUNT BY OVERFLOW)

When a display value near the maximum display capability is forced into a numerical overflow by changing the CNT BY menu (for example, the display reads 999997 and the count by is changed from 001 to 005 and rounds the display up to 1000000).

17.1.11 FLASHING "UOM.OVF" (UNIT OF MEASURE OVERFLOW)

If a unit of measure is selected and you are near the full scale capability of the display and in the ACTIVE decimal mode, the display will shift one digit to the left (for example, to a display of 1065.33 you add a unit of measure such as "F" for a display of 1065.33F), the display will flash "UOM.OVF".

17.2 TROUBLESHOOTING GUIDE

"99999"

POSSIBLE CAUSE: Active decimal point change driving the display into numerical overload.

TO CORRECT: Press the 'MAX' button to reset the entire display to all zeros, then enter a revised number into the submenu item that caused the overflow.

"ERR 01"

POSSIBLE CAUSE: Active decimal ("RDG.2=0") has been selected and/or DEC PT (decimal point) position has been moved one or more places to the left driving the programmed offset value into numerical overflow.

TO CORRECT: Press the 'MENU' button and the meter will show the left most decimal point position possible for the chosen offset: by pressing the 'MENU' button again this revised entry is stored.

Alternately, the amount of RDG.OF may be reduced to get the decimal point further to the left.

"ERR 02"

POSSIBLE CAUSE: Active decimal (RDG.2) has been selected and/or DEC PT (decimal point) position has been moved one or more places to the left driving the programmed Setpoint value into numerical overflow.

TO CORRECT: Display will flash "ERR 02" message for a short period of time, then automatically

continued next page

correct the setpoint's decimal point position and move to the next menu item. Press the 'SETPT' button until the meter displays flashing "999999". Then press the 'MAX' button to reset the display to "000000" and enter a new valid setpoint value.

"+OVLD"

POSSIBLE CAUSE: In the LINEAR (RTD) mode, jumpers S2A and S2F on the signal input board are installed and input signal exceeds 690 ohms or jumpers S2A and S2D are installed and the input signal exceeds 6900 ohms. (Place the active decimal point all the way to the right side: "FFFFFF. ").

TO CORRECT: Check both the input range and the actual input to find the error condition. To correct, either reduce the input or change jumpers to a higher input range for more input attenuation.

"+OPEN"

POSSIBLE CAUSE: Input sensor is open or broken, or the connection to the meter is open or broken. Input sensor is not wired to the proper input terminals.

TO CORRECT: Check thermocouple or RTD wiring.

"-OPEN"

POSSIBLE CAUSE: The input sensor is open or broken, or the connection to the meter is open or broken. The input sensor is not wired to the proper input terminals. The input signal is below the minimum specified (refer to Section 18, Specifications).

TO CORRECT: When jumper S2R on the signal input board is used, this will be indicated if a sensor lead is broken or otherwise opened. Check thermocouple or RTD wiring.

"I OVSC"

POSSIBLE CAUSE: The input scale and/or offset values chosen are large enough to drive the display into numerical overflow.

continued next page

continued from previous page

TO CORRECT: Reduce the input and/or the input scaling/offset. Refer to "IN.SC.OF" in Section 9.2.5.

"R OVSC"

POSSIBLE CAUSE: The reading scale and/or offset values chosen are large enough to drive the display into numerical overflow.

TO CORRECT: Reduce the READING scale/offset and/or move the active decimal point to the right. Reducing INPUT scale/offset is not required, because the input overscale message has higher priority than this message and would be displayed if there were an input overscale.

"CB OVf"

POSSIBLE CAUSE: CNT BY (count by value) has been changed causing the display to round up to a numerical overflow.

TO CORRECT: Reduce the "CNT BY" count by value to 001. If you have an active decimal point selected, move the decimal point one or more positions to the right.

"UOM.OVF"

POSSIBLE CAUSE: Selection of unit of measure displayed ("RDG.6=0") moves the display reading one place to the left causing a numerical overflow.

TO CORRECT: If you have an active decimal point, move the decimal point position one or more positions to the right.

"SERIAL"

POSSIBLE CAUSE: A configuring change has been attempted via the front panel buttons while the serial communications port is actively communicating with the meter.

TO CORRECT: Either lockout the front panel buttons by removing the jumpers S3A & S3C or disconnect the serial communications option.

This page is intentionally left blank

18. Specifications

18.1 THERMOCOUPLE INPUT

TC Type	Degrees, Temperature : Accuracy	
	Celsius	Fahrenheit
J	-210 to 760 : 0.2	-346 to 1400 : 0.3
K	-270 to 1372 : 0.2	-454 to 2500 : 0.3
E	-270 to 1000 : 0.2	-454 to 1832 : 0.3
T	-270 to 400 : 0.2	-454 to 752 : 0.3
N	-270 to 1300 : 0.2	-454 to 2372 : 0.3
R	-50 to 1768 : 0.2	-58 to 3214 : 0.3
S	-50 to 1768 : 0.2	-58 to 3214 : 0.3
B	+100 to 1820 : 0.3	+212 to 3300 : 0.5
DIN J	-200 to 900 : 0.6	-328 to 1652 : 1.0

NOTE: For accurate full scale measurements below -40 degrees, you may need to complete the full scale cold junction calibration procedure (Refer to Section 6.7.2, Special Cold-Junction Calibration).

Calibration: NIST #125, DIN 43710

Reference Junction: Either a remote ice-point cell or an oven can be used in place of the supplied Cold-Junction Compensation Board. Curvalinear correction to better than 40 dB ambient-temperature rejection.

18.2 RTD INPUT

RTD Type	Temperature : Accuracy	
	Celsius	Fahrenheit
Pt100	-200 to 850 : 0.2	-328 to 1562 : 0.3
NIST		
Pt100	-200 to 900 : 0.2	-328 to 1652 : 0.3
DIN		
Cu10 (Linear)	-200 to 200 : 1.0	-328 to 392 : 2.0

continued next page

continued from previous page

(Either of the two linearizations or the non-linearized scaling may be applied to RTDs with R-zero values as low as 10 ohms or as high as 1000 ohms, using field calibration and selection of excitation and input range.)

RESOLUTION: 1, 0.1, 0.01

VOLTAGE
EXCITATION:

Transmitters: 24 V, to 25 mA

CURRENT: 160 μ A, factory calibrated, auto-compensation

EXCITATION: 1.6 mA, can be field calibrated with EEPROM storage (RTDs or OHMS):

LEAD RESISTANCE (for specified accuracy)

THERMOCOUPLES: to 100 ohms, total
2-wire 100 ohm RTD: 50 milliohms/lead
3-wire 100 ohm RTD: 5 ohms/lead, balanced
4-wire 100 ohm RTD: 10 ohms total, unbalanced

18.3 GENERAL

SCALE: Celsius (C), Fahrenheit (F), or Kelvin (K)
(programmable units display)

+0.000001 to +500000 or -0.0001 to -99999, multiplier capability both before and after linearization (for transmitter input); also for conversion of any ohmic sensor to engineering units.

OFFSET: Zero to +999999 or -99999, both before and after linearization (for transmitter input); also for offsets of resistance inputs.

POLARITY: Automatic
Input range jumpered for -10/+110% or -55/+55% of selected span

continued next page

*continued from previous page***NOISE REJECTION**

NMR:	60 dB, 50 or 60 Hz, + selected filter
CMR:	120 dB
CMV:	1500 V peak test, 354 V per IEC spacing

ACCURACY at 25°C:

MAX ERROR:	±0.005% of reading
SPAN TEMPCO:	less than 20 ppm/deg C
STEP RESPONSE:	1 second to 99.9%
WARMUP:	55 minutes to rated accuracy. It is recommended that the unit be continuously running to insure its accuracy.

CONVERSION

TECHNIQUE:	Dual-slope READ RATE/Programmable
INTEGRATION TIME:	3 samples/sec: 100msec 12 samples/sec, 60 Hz: 16.7msec 11 samples/sec, 50 Hz: 20msec

DISPLAY

LEDs:	6, 0.54" (13.8mm)h, red, 14-segment 4, 0.12" x 0.24" (3 x 6mm), red lamp
SYMBOLS:	-.8.8.8.8.8. or 8.8.8.8.8.8.
DECIMAL POINT POSITION:	Programmable

COMMUNICATIONS INFORMATION

BREAK PROTECTION:	Up- or down-scale, programmable
OUTPUTS (STANDARD):	4, TTL isolated open-collector; 150 mA at 1V sink; 30 V open
BCD OUTPUT (OPTIONAL):	Tri-state, TTL/CMOS compatible; internal 5 V supply for non-isolated, external 5 V supply for isolated.

continued next page

continued from previous page

DUAL RELAYS: (OPTIONAL)	Form C, 7A at 30V dc or 230VA ac (Resistive)
ANALOG OUTPUT: (OPTIONAL)	0-5 V, 1-5 V, 0-10 V, 0-20 mA, 4-20 mA level; compliance, 12 V at 20 mA; 15-bit resolution; 0.1% accuracy; programmable zero and span.

TURNDOWN RATIO

(MAX OFFSET-
MIN SPAN): 1000 with 0.1% or 100 with 0.01%
resolution

RS-232

COMMUNICATIONS: RJ11 4-wire connection; complete
(OPTIONAL) program setup and message display
capability; programmable to transmit
current display, alarm status, min/max,
and status

BAUD RATES: 300, 600, 1200, 2400, 4800, 9600, 19200

RS-485

COMMUNICATIONS: RJ12 6-wire connection; addressable
(OPTIONAL) from "000" to "199".

BAUD RATES: 300, 600, 1200, 2400, 4800, 9600, 19200

FLASHING MESSAGES

DURING PROGRAMMING (configuration mode)

NUMERICAL OVERFLOW:	"999999"
OFFSET OVERFLOW:	"ERR 01"
SETPOINT OVERFLOW:	"ERR 02"
NOT STORED IN EEPROM:	"NOSTOR"
VALUE PUT IN EEPROM:	"STORED"

continued next page

continued from previous page

DURING MEASUREMENT (RUN MODE)

INPUT TOO LARGE, POSITIVE:	"+ OVLD"
INPUT TOO LARGE, NEGATIVE:	"- OVLD"
INPUT OUT OF RANGE, POSITIVE:	"+ OPEN"
INPUT OUT OF RANGE, NEGATIVE:	"- OPEN"
EXCESS INPUT SCALE/OFFSET:	"I OVSC"
EXCESS DISPLAY SCALE/OFFSET:	"R OVSC"
COUNT-BY DISPLAY OVERFLOW:	"999999"

DURING SETPOINT ADJUST (RUN MODE)

OUT OF SELECTED DIGIT RANGE:	"999999"
NOT STORED IN EEPROM:	"NOSTOR"
VALUE PUT IN EEPROM:	"STORED"

POWER

AC VOLTAGES:	115 V \pm 10%, 50/60 Hz or 230 V \pm 10% (RMS)
AC FREQUENCY:	49 to 100 Hz (to 440 Hz with 110 or 220 V minimum)
DC VOLTAGE:	9.5 to 32 Watts at nominal line: 5 W with no options, 10W loaded

ENVIRONMENTAL

OPERATING TEMP RANGE:	32 to 122°F (0 TO 50°C)
STORAGE TEMP RANGE:	-40 to 185°F (-40 to 85°C)
HUMIDITY:	up to 90% non-condensing at 104° F (40° C)
FRONT-PANEL:	NEMA-4 rated

continued next page

continued from previous page

MECHANICAL

DIMENSIONS (H x W x D): 1.89" x 3.78" x 5.86"
(48mm x 96mm x 148.8mm)
(add 0.27 inches or 6.8mm depth for Cold-Junction Compensation Board). Refer to Figure 18-1 for the dimensions of the standard meter with the bezel. Refer to Figure 18-2 for dimensions of the basic meter with the optional bezel.

WEIGHT: 1.316 pounds (600 g)

MATERIAL: 94V-0 UL-rated Polycarbonate

Dimensions in inches (mm)

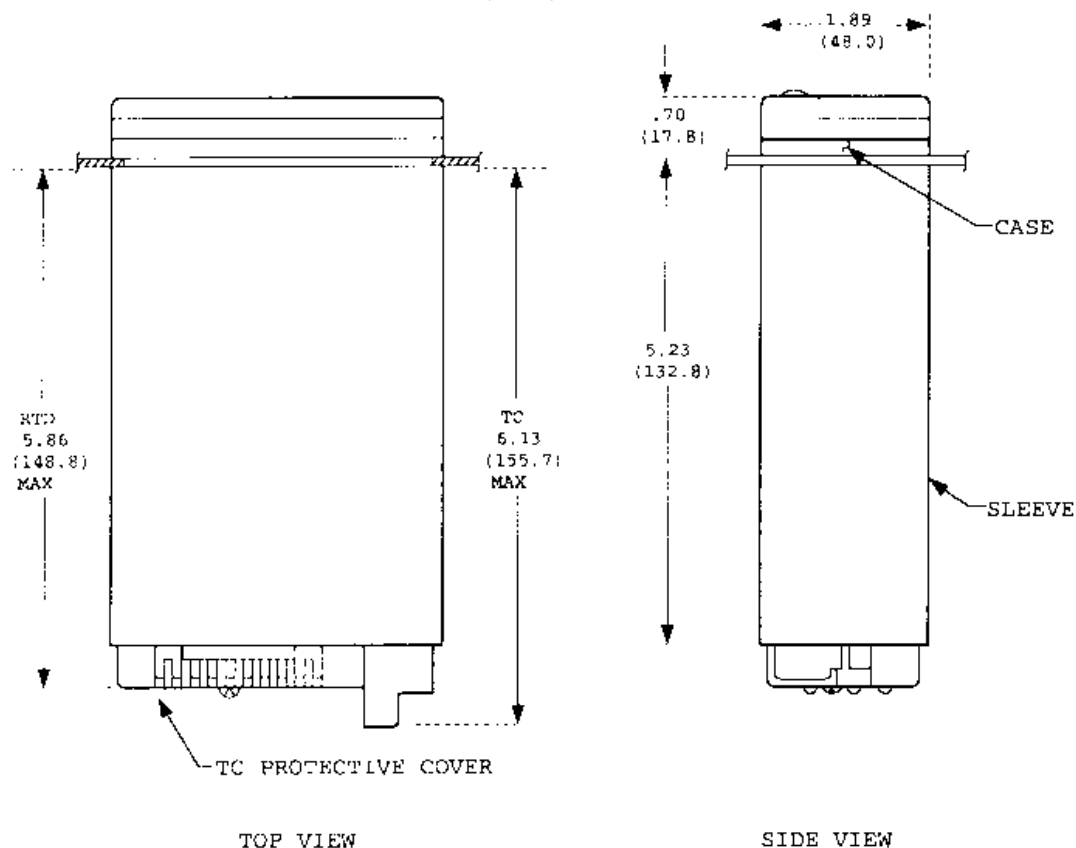

Figure 18-1. Meter Dimensions

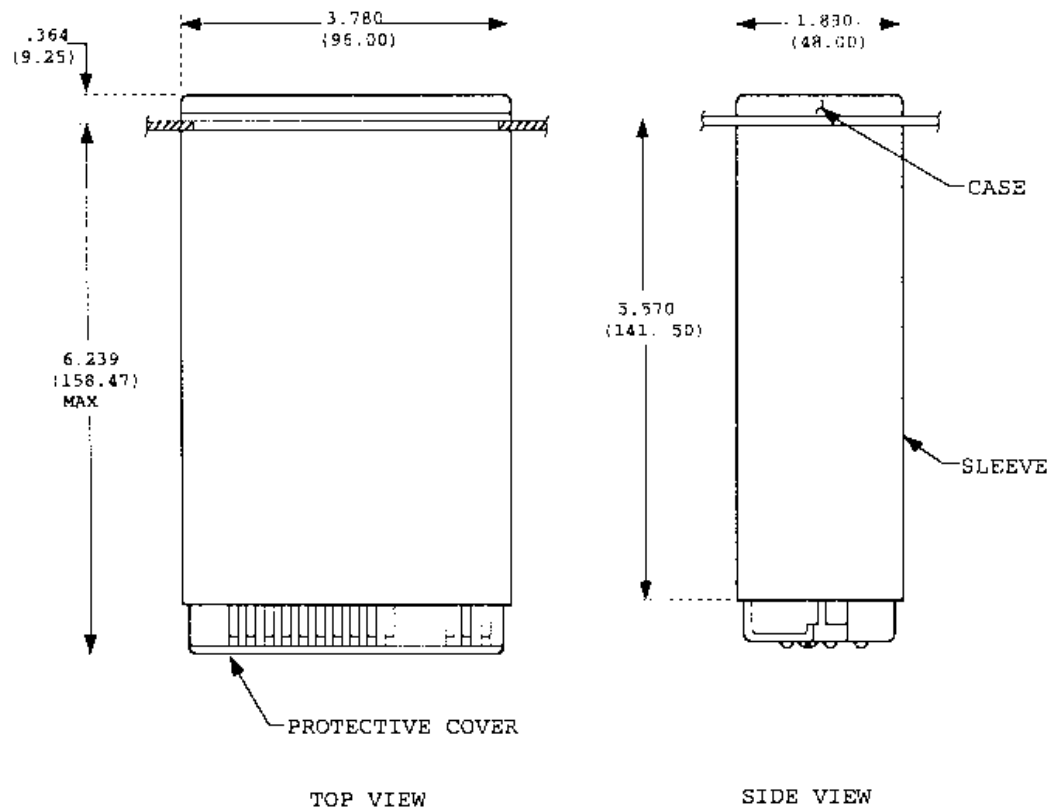

Figure 18-2. Meter Dimensions Optional ("OH") Housing

This page is intentionally left blank

19. Factory Preset Values

JUMPER POSITIONS:

Thermocouple

S1: C S2: A, F, J, K, O, S
S3: A, C S4: NONE

RTD

S1: NONE S2: A, F, H, P, S
S3: A, C S4: None

LOCKOUT CONFIGURATION(S)

L1 CNF	L2 CNF	L3 CNF	L4 CNF
L1C.1=0	L2C.1=0	L3C.1=0	L4C.1=0
L1C.2=0	L2C.2=0	L3C.2=0	L4C.2=0
L1C.3=0	L2C.3=0	L3C.3=0	L4C.3=0
L1C.4=0	L2C.4=0	L3C.4=0	L4C.4=0
L1C.5=0	L2C.5=0	L3C.5=0	L4C.5=0
L1C.6=0	L2C.6=0	L3C.6=0	L4C.6=1
L1C.7=0	L2C.7=0	L3C.7=0	L4C.7=0
L1C.8=0	L2C.8=0	L3C.8=0	

Input Class: For Thermocouple: "TC"
 For RTD: "RTD"

Input Type: For Thermocouple: "K"
 For RTD: "3PT385"

Reading Configuration "RDG.CNF":

RDG.1=1	RDG.2=0	RDG.3=0	RDG.4=1
RDG.5=1	RDG.6=1	RDG.7=0	

Reading Scale & Offset

(2-Coordinate Format):

INPUT 1= 00000.0	READ 1= 00000.0
INPUT 2= 10000.0	READ 2= 10000.0

Input Configuration "IN CNF":

INP.1=0	INP.2=0	INP.3=0	INP.4=0
INP.5=0	INP.6=0	INP.7=0	

Input Scale and Offset "IN.SC.OF":

INPUT 1: 00000.0 READ 1: 00000.0
 INPUT 2: 10000.0 READ 2: 10000.0

Decimal Point "DEC PT" Position: FFFFF.F

Count By "CNT BY": 001

Filter Configuration "FIL.CNF": FIL.1=0 FIL.2=1 FIL.3=1

Filter Time Constant "FIL TI": 064

Setpoint Configuration "SP CNF":

SPC.1=0 SPC.2=0 SPC.3=1 SPC.4=0
 SPC.5=0 SPC.6=1 SPC.7=0 SPC.8=0

Alarm Configuration "AL CNF":

ALC.1=0 ALC.2=0 ALC.3=1 ALC.4=0
 ALC.5=0 ALC.6=1 ALC.7=0 ALC.8=0

Alarm Function "AL FNC":

ALF.1=0 ALF.2=0 ALF.3=0 ALF.4=0

Alarm Number of Readings "AL RDG": 03 03 for (AL1)
 (AL2)

Setpoints 1 & 2 Deadband "SP DB": 0020

Alarms 1 & 2 Deadband "AL DB": 0020

Output Configuration "OUT.CNF":

OUT.1=0 OUT.2=1 OUT.3=0 OUT.4=0
 OUT.5=1 OUT.6=0

Output Scale and Offset "OT.SC.OF":

READ 1: 00000.0 OUTPT 1: 04.0000
 READ 2: 10000.0 OUTPT 2: 20.0000

Baud Rate "BAUD": 09600

Serial Communication Configuration "SERCNF":

SER.1=1 SER.2=0

Address "ADDRES" (for RS-485): 001

Data Format "DAT FT":

DAT.1=0 DAT.2=0 DAT.3=1 DAT.4=0
 DAT.5=0 DAT.6=0 DAT.7=0 DAT.8=0

Bus Format "BUS FT":

BUS.1=0 BUS.2=0 BUS.3=1 BUS.4=0
 BUS.5=1 BUS.6=0 BUS.7=0 BUS.8=1

Serial Count "SERCNT": 00001

ANALOG OUTPUT

CAL VZ:	_____
CAL VS:	_____
CAL mAZ:	_____
CAL mAS:	_____

TC COLD-JUNCTION OFFSET

MENU	SUB MENU	DESCRIPTION
CJUN.OF:	_____	Calibration of TC offset. Enter offset = 270 x error in degrees C if positive; or = -270 x error in degrees C + 32767 if negative.

This page is intentionally left blank

20. Record Your Setup Values

JUMPER POSITIONS:

Thermocouple

S1: _____ S2: _____
S3: _____ S4: Not used

RTD

S1: _____ S2: _____
S3: _____ S4: Not used

LOCKOUT CONFIGURATION(S)

L1 CNF	L2 CNF	L3 CNF	L4 CNF
L1C.1=___	L2C.1=___	L3C.1=___	L4C.1=___
L1C.2=___	L2C.2=___	L3C.2=___	L4C.2=___
L1C.3=___	L2C.3=___	L3C.3=___	L4C.3=___
L1C.4=___	L2C.4=___	L3C.4=___	L4C.4=___
L1C.5=___	L2C.5=___	L3C.5=___	L4C.5=___
L1C.6=___	L2C.6=___	L3C.6=___	L4C.6=___
L1C.7=___	L2C.7=___	L3C.7=___	L4C.7=___
L1C.8=___	L2C.8=___	L3C.8=___	

Input Class: "TC": _____
(check one) "RTD": _____

Input Type: For Thermocouple: _____
For RTD: _____

Reading Configuration "RDG.CNF":

RDG.1=___ RDG.2=___ RDG.3=___ RDG.4=___
RDG.5=___ RDG.6=___ RDG.7=___

Reading Scale and Reading Offset "RDG SC" and "RDG OF"
(Direct Format):

Reading Scale "RDG SC": _____
Reading Offset "RDG OF": _____

Reading Scale & Offset

(2-coordinate Format):

INPUT 1= _____ READ 1= _____
INPUT 2= _____ READ 2= _____

Input Configuration "IN CNF":

INP.1=___ INP.2=___ INP.3=___ INP.4=___
 INP.5=___ INP.6=___ INP.7=___

Input Scale and Offset "IN.SC.OF":

INPUT 1: _____ READ 1: _____
 INPUT 2: _____ READ 2: _____

Decimal Point "DEC PT" Position: F__F__F__F__F__F__

Count By "CNT BY": _____

Filter Configuration "FIL.CNF": FIL.1=___ FIL.2=___ FIL.3=___

Filter Time Constant "FIL TI": _____

Setpoint Configuration "SP CNF":

SPC.1=___ SPC.2=___ SPC.3=___ SPC.4=___
 SPC.5=___ SPC.6=___ SPC.7=___ SPC.8=___

Alarm Configuration "AL CNF":

ALC.1=___ ALC.2=___ ALC.3=___ ALC.4=___
 ALC.5=___ ALC.6=___ ALC.7=___ ALC.8=___

Alarm Function "AL FNC":

ALF.1=___ ALF.2=___ ALF.3=___ ALF.4=___

Alarm Number of Readings "AL RDG": _____

Setpoints Deadband "SP DB": _____

Alarms 1 & 2 Deadband "AL DB": _____

Output Configuration "OUT.CNF":

OUT.1=___ OUT.2=___ OUT.3=___ OUT.4=___
 OUT.5=___ OUT.6=___ OUT.7=___ OUT.8=___

Output Scale and Offset "OT.SC.OF":

READ 1: _____ OUTPT 1: _____
 READ 2: _____ OUTPT 2: _____

Baud Rate "BAUD": _____

Serial Communication Configuration "SERCNF":

SER.1=___ SER.2=___

Address "ADDRES" (for RS-485): _____

Data Format "DAT FT":

DAT.1=___ DAT.2=___ DAT.3=___ DAT.4=___
DAT.5=___ DAT.6=___ DAT.7=___ DAT.8=___

Bus Format "BUS FT":

BUS.1=___ BUS.2=___ BUS.3=___ BUS.4=___
BUS.5=___ BUS.6=___ BUS.7=___ BUS.8=___

Serial Count "SERCNT": _____

ANALOG OUTPUT

CAL VZ:	_____
CAL VS:	_____
CAL mAZ:	_____
CAL mAS:	_____

TC COLD-JUNCTION OFFSET

MENU	SUB MENU	DESCRIPTION
CJUN.OF:	_____	Calibration of TC offset. Enter offset = 270 x error in degrees C if positive; or = -270 x error in degrees C + 32767 if negative.

This page is intentionally left blank

21. Appendices

APPENDIX A TYPE J MICROVOLTS AT EACH 10 DEGREES CELSIUS

TEMP	μVOLT	TEMP	μVOLT	TEMP	μVOLT
-210	-8095.6	150	8008.1	500	27388.2
-200	-7890.5	160	8560.3	510	27948.7
-190	-7658.7	170	9113.4	520	28510.9
-180	-7402.2	180	9667.2	530	29075.1
-170	-7122.4	190	10221.7	540	29641.5
-160	-6821.0	200	10776.5	550	30210.3
-150	-6499.3	210	11331.7	560	30781.6
-140	-6158.8	220	11887.0	570	31355.7
-130	-5800.6	230	12442.4	580	31932.7
-120	-5426.0	240	12997.7	590	32512.7
-110	-5036.2	250	13552.9	600	33096.0
-100	-4632.1	260	14107.9	610	33682.7
-90	-4214.8	270	14662.7	620	34272.9
-80	-3785.2	280	15217.2	630	34866.7
-70	-3344.1	290	15771.3	640	35464.3
-60	-2892.5	300	16325.1	650	36065.6
-50	-2431.0	310	16878.5	660	36670.8
-40	-1960.4	320	17431.5	670	37279.9
-30	-1481.4	330	17984.2	680	37892.9
-20	-994.6	340	18536.5	690	38509.7
-10	-500.6	350	19088.5	700	39130.2
0	0	360	19640.2	710	39754.4
10	506.7	370	20191.8	720	40382.0
20	1019.0	380	20743.2	730	41012.9
30	1536.4	390	21294.5	740	41646.8
40	2058.4	400	21845.9	750	42283.2
50	2584.8	410	22397.4	760	42922.0
60	3115.0	420	22949.1		
70	3648.7	430	23501.2		
80	4185.6	440	24053.8		
90	4725.4	450	24607.1		
100	5267.7	460	25161.1		
110	5812.3	470	25716.1		
120	6358.8	480	26272.1		
130	6907.1	490	26829.5		
140	7456.9				

APPENDIX B TYPE K MICROVOLTS AT EACH 10 DEGREES CELSIUS

TEMP	μVOLT	TEMP	μVOLT	TEMP	μVOLT
-270	-6457.8	130	5327.4	530	21919.1
-260	-6441.2	140	5733.5	540	22345.5
-250	-6403.7	150	6137.2	550	22771.9
-240	-6343.9	160	6538.9	560	23198.3
-230	-6261.9	170	6939.2	570	23624.4
-220	-6158.5	180	7338.4	580	24050.4
-210	-6034.6	190	7737.3	590	24476.2
-200	-5891.4	200	8136.6	600	24901.6
-190	-5729.6	210	8536.6	610	25326.7
-180	-5550.2	220	8937.8	620	25751.4
-170	-5353.8	230	9340.6	630	26175.6
-160	-5141.0	240	9745.2	640	26599.3
-150	-4912.5	250	10151.5	650	27022.4
-140	-4668.7	260	10559.6	660	27445.0
-130	-4410.3	270	10969.3	670	27866.9
-120	-4137.9	280	11380.7	680	28288.1
-110	-3852.0	290	11793.4	690	28708.6
-100	-3553.2	300	12207.4	700	29128.3
-90	-3242.3	310	12622.6	710	29547.2
-80	-2919.8	320	13038.7	720	29965.3
-70	-2586.3	330	13455.7	730	30382.5
-60	-2242.5	340	13873.6	740	30798.9
-50	-1889.1	350	14292.2	750	31214.3
-40	-1526.6	360	14711.6	760	31628.7
-30	-1155.9	370	15131.6	770	32042.2
-20	-777.4	380	15552.3	780	32454.7
-10	-391.9	390	15973.6	790	32866.3
0	0	400	16395.4	800	33276.8
10	397.0	410	16817.9	810	33686.3
20	798.1	420	17240.9	820	34094.7
30	1203.1	430	17664.4	830	34502.1
40	1611.4	440	18088.4	840	34908.5
50	2022.4	450	18512.8	850	35313.8
60	2435.7	460	18937.6	860	35718.1
70	2850.3	470	19362.8	870	36121.3
80	3265.7	480	19788.4	880	36523.5
90	3680.9	490	20214.1	890	36924.6
100	4095.3	500	20640.2	900	37324.7
110	4508.1	510	21066.4	910	37723.8
120	4919.0	520	21492.7	920	38121.8

APPENDIX B (cont.) TYPE K MICROVOLTS AT EACH 10 DEGREES CELSIUS

TEMP	μVOLT	TEMP	μVOLT
930	38518.7	1330	53438.6
940	38914.7	1340	53782.4
950	39309.6	1350	54125.0
960	39703.4	1360	54466.4
970	40096.3	1370	54806.9
980	40488.1		
990	40878.9		
1000	41268.7		
1010	41657.5		
1020	42045.2		
1030	42431.8		
1040	42817.5		
1050	43202.0		
1060	43585.5		
1070	43967.9		
1080	44349.1		
1090	44729.3		
1100	45108.3		
1110	45486.1		
1120	45862.7		
1130	46238.0		
1140	46612.1		
1150	46984.9		
1160	47356.3		
1170	47726.4		
1180	48095.1		
1190	48462.3		
1200	48828.0		
1210	49192.3		
1220	49555.0		
1230	49916.1		
1240	50275.6		
1250	50633.5		
1260	50989.7		
1270	51344.4		
1280	51697.4		
1290	52048.7		
1300	52398.5		
1310	52746.7		
1320	53093.3		

APPENDIX C

TYPE T MICROVOLTS AT EACH 10 DEGREES CELSIUS

TEMP	μ VOLT	TEMP	μ VOLT	TEMP	μ VOLT
-270	-6257.6	0	0	250	12011.3
-260	-6231.8	10	390.9	260	12571.7
-250	-6180.5	20	789.4	270	13136.9
-240	-6105.1	30	1196.2	280	13706.8
-230	-6006.8	40	1611.4	290	14281.1
-220	-5888.5	50	2035.2	300	14859.8
-210	-5753.3	60	2467.5	310	15442.8
-200	-5602.9	70	2908.1	320	16030.0
-190	-5438.6	80	3356.8	330	16621.4
-180	-5260.6	90	3813.3	340	17216.8
-170	-5069.4	100	4277.3	350	17816.4
-160	-4865.2	110	4748.7	360	18419.9
-150	-4648.2	120	5227.0	370	19027.2
-140	-4418.7	130	5712.2	380	19638.2
-130	-4176.8	140	6204.1	390	20252.3
-120	-3922.6	150	6702.4	400	20869.2
-110	-3656.4	160	7207.0		
-100	-3378.2	170	7717.8		
-90	-3088.6	180	8234.7		
-80	-2787.6	190	8757.5		
-70	-2475.4	200	9286.1		
-60	-2152.4	210	9820.3		
-50	-1818.7	220	10360.2		
-40	-1474.7	230	10905.4		
-30	-1120.7	240	11455.8		
-20	-756.7				
-10	-383.0				

APPENDIX D TYPE E MICROVOLTS AT EACH 10 DEGREES CELSIUS

TEMP	μVOLT	TEMP	μVOLT	TEMP	μVOLT
-270	-9835.0	170	11222.0	570	42661.9
-260	-9796.7	180	11948.7	580	43470.0
-250	-9718.6	190	12681.0	590	44277.6
-240	-9604.2	200	13418.6	600	45084.7
-230	-9455.2	210	14161.3	610	45891.1
-220	-9273.9	220	14908.8	620	46696.8
-210	-9062.9	230	15660.8	630	47501.8
-200	-8824.5	240	16417.2	640	48305.9
-190	-8560.8	250	17177.5	650	49109.2
-180	-8273.2	260	17941.8	660	49911.5
-170	-7963.1	270	18709.6	670	50712.8
-160	-7631.3	280	19480.9	680	51513.0
-150	-7278.9	290	20255.5	690	52312.2
-140	-6906.9	300	21033.1	700	53110.3
-130	-6515.9	310	21813.6	710	53907.2
-120	-6106.8	320	22596.9	720	54703.0
-110	-5680.2	330	23382.7	730	55497.5
-100	-5236.7	340	24170.9	740	56290.8
-90	-4776.8	350	24961.4	750	57082.8
-80	-4301.3	360	25754.0	760	57873.4
-70	-3810.8	370	26548.5	770	58662.7
-60	-3305.8	380	27344.9	780	59450.7
-50	-2786.8	390	28143.0	790	60237.2
-40	-2254.4	400	28942.7	800	61022.3
-30	-1709.1	410	29743.9	810	61805.8
-20	-1151.3	420	30546.3	820	62587.9
-10	-581.5	430	31349.9	830	63368.3
0	0	440	32154.7	840	64147.1
10	591.3	450	32960.3	850	64924.3
20	1191.5	460	33766.9	860	65699.7
30	1800.8	470	34574.1	870	66473.3
40	2419.2	480	35381.9	880	67245.2
50	3046.8	490	36190.3	890	68015.1
60	3683.4	500	36999.0	900	68783.1
70	4328.9	510	37808.0	910	69549.1
80	4983.2	520	38617.1	920	70313.2
90	5646.0	530	39426.3	930	71075.3
100	6317.1	540	40235.5	940	71835.3
110	6996.1	550	41044.6	950	72593.4
120	7682.9	560	41853.4	960	73349.6
130	8377.1			970	74103.9
140	9078.4			980	74856.6
150	9786.5			990	75607.7
160	10501.2			1000	76357.5

APPENDIX E TYPE N MICROVOLTS AT EACH 10 DEGREES CELSIUS

For negative temperatures, AWG 28 data; above 400, AWG 14 data; between, linear blend).

TEMP	μVOLT	TEMP	μVOLT	TEMP	μVOLT
-270	-4345.2	100	2778.8	450	14844.0
-260	-4335.7	110	3077.6	460	15221.9
-250	-4313.3	120	3380.0	470	15601.0
-240	-4277.0	130	3686.0	480	15981.1
-230	-4226.5	140	3995.4	490	16362.3
-220	-4161.8	150	4308.2	500	16744.4
-210	-4083.0	160	4624.2	510	17127.4
-200	-3990.4	170	4943.3	520	17511.3
-190	-3884.4	180	5265.5	530	17896.1
-180	-3765.6	190	5590.6	540	18281.6
-170	-3634.3	200	5918.7	550	18667.9
-160	-3491.0	210	6249.6	560	19054.9
-150	-3336.2	220	6583.2	570	19442.6
-140	-3170.3	230	6919.5	580	19830.9
-130	-2993.9	240	7258.4	590	20219.9
-120	-2807.5	250	7599.9	600	20609.3
-110	-2611.5	260	7943.8	610	20999.3
-100	-2406.6	270	8290.1	620	21389.8
-90	-2193.2	280	8638.7	630	21780.7
-80	-1972.1	290	8989.5	640	22171.9
-70	-1743.8	300	9342.4	650	22563.6
-60	-1509.0	310	9697.3	660	22955.5
-50	-1268.4	320	10054.3	670	23347.8
-40	-1022.6	330	10413.1	680	23740.3
-30	-772.2	340	10773.7	690	24132.9
-20	-517.9	350	11136.1	700	24525.8
-10	-260.3	360	11500.1	710	24918.8
0	0	370	11865.8	720	25311.9
10	262.5	380	12233.1	730	25705.0
20	527.6	390	12601.9	740	26098.2
30	795.8	400	12972.2	750	26491.4
40	1067.4	410	13343.9	760	26884.5
50	1342.8	420	13717.1	770	27277.6
60	1622.1	430	14091.5	780	27670.6
70	1905.4	440	14467.1	790	28063.4
80	2192.6				
90	2483.8				

APPENDIX E (cont.)
TYPE N MICROVOLTS AT EACH 10 DEGREES CELSIUS

TEMP	μ VOLT	TEMP	μ VOLT
800	28456.1	1150	41966.2
810	28848.7	1160	42342.2
820	29241.0	1170	42717.0
830	29633.2	1180	43091.1
840	30025.1	1190	43464.0
850	30416.7	1200	43836.3
860	30808.0	1210	44207.3
870	31199.1	1220	44577.7
880	31589.7	1230	44946.9
890	31980.1	1240	45314.7
900	32370.2	1250	45682.0
910	32759.8	1260	46048.3
920	33149.0	1270	46413.1
930	33538.0	1280	46776.8
940	33926.5	1290	47140.3
950	34314.5	1300	47502.1
960	34702.1		
970	35089.3		
980	35476.1		
990	35862.3		
1000	36248.1		
1010	36633.4		
1020	37018.2		
1030	37402.4		
1040	37786.2		
1050	38169.5		
1060	38552.0		
1070	38934.1		
1080	39315.3		
1090	39696.2		
1100	40076.5		
1110	40456.0		
1120	40834.6		
1130	41212.6		
1140	41589.9		

APPENDIX F TYPE R MICROVOLTS AT EACH 10 DEGREES CELSIUS

TEMP	μVOLT	TEMP	μVOLT	TEMP	μVOLT
-50	-226.4	300	2400.1	700	6741.2
-40	-187.7	310	2497.8	710	6859.8
-30	-145.5	320	2596.3	720	6978.9
-20	-100.0	330	2695.4	730	7098.4
-10	-51.5	340	2795.3	740	7218.5
0	0	350	2895.7	750	7339.0
10	54.3	360	2996.8	760	7460.0
20	111.2	370	3098.5	770	7581.5
30	170.6	380	3200.9	780	7703.5
40	232.4	390	3303.7	790	7825.9
50	296.5	400	3407.2	800	7948.8
60	362.7	410	3511.2	810	8072.2
70	431.0	420	3615.7	820	8196.0
80	501.2	430	3720.8	830	8320.3
90	573.3	440	3826.4	840	8445.1
100	647.2	450	3932.5	850	8570.3
110	722.8	460	4039.1	860	8691.0
120	800.0	470	4146.3	870	8822.2
130	878.8	480	4253.9	880	8948.8
140	959.1	490	4362.0	890	9075.8
150	1040.7	500	4470.6	900	9203.4
160	1123.7	510	4579.6	910	9331.3
170	1208.0	520	4689.2	920	9459.7
180	1293.6	530	4799.2	930	9588.6
190	1380.3	540	4909.7	940	9717.9
200	1468.1	550	5020.6	950	9847.7
210	1557.1	560	5132.0	960	9977.9
220	1647.1	570	5243.9	970	10108.6
230	1738.1	580	5356.2	980	10239.7
240	1830.0	590	5469.0	990	10371.2
250	1922.9	600	5582.3	1000	10503.2
260	2016.7	610	5696.0	1010	10635.6
270	2111.3	620	5810.1	1020	10768.4
280	2206.8	630	5924.6	1030	10901.7
290	2303.0	640	6039.8	1040	11035.4
		650	6155.4	1050	11169.5
		660	6271.6	1060	11304.1
		670	6388.3	1070	11439.1
		680	6505.4	1080	11574.5
		690	6623.0	1090	11710.2

APPENDIX F(cont.) TYPE R MICROVOLTS AT EACH 10 DEGREES CELSIUS

TEMP	μ VOLT	TEMP	μ VOLT
1100	11846.3	1450	16740.5
1110	11982.7	1460	16881.6
1120	12119.4	1470	17022.5
1130	12256.5	1480	17163.4
1140	12393.9	1490	17304.1
1150	12531.5	1500	17444.7
1160	12669.5	1510	17585.2
1170	12807.7	1520	17725.6
1180	12946.2	1530	17865.9
1190	13084.9	1540	18005.9
1200	13223.9	1550	18145.8
1210	13363.1	1560	18285.5
1220	13502.5	1570	18425.1
1230	13642.1	1580	18564.4
1240	13781.8	1590	18703.5
1250	13921.8	1600	18842.4
1260	14061.9	1610	18981.0
1270	14202.2	1620	19119.4
1280	14342.6	1630	19257.5
1290	14483.2	1640	19395.3
1300	14623.9	1650	19532.9
1310	14764.7	1660	19670.2
1320	14905.6	1670	19807.1
1330	15046.5	1680	19943.7
1340	15187.6	1690	20079.7
1350	15328.7	1700	20215.1
1360	15469.8	1710	20349.7
1370	15611.0	1720	20483.4
1380	15752.2	1730	20616.1
1390	15893.5	1740	20747.5
1400	16034.7	1750	20877.7
1410	16175.9	1760	21006.4
1420	16317.2		
1430	16458.3		
1440	16599.5		

APPENDIX G TYPE S MICROVOLTS AT EACH 10 DEGREES CELSIUS

TEMP	μVOLT	TEMP	μVOLT	TEMP	μVOLT
-50	-235.7	350	2785.8	700	6274.3
-40	-194.4	360	2879.8	710	6379.9
-30	-150.1	370	2974.2	720	6485.8
-20	-102.8	380	3069.0	730	6592.0
-10	-52.7	390	3164.2	740	6698.6
0	0	400	3259.7	750	6805.5
10	55.2	410	3355.7	760	6912.7
20	112.8	420	3451.9	770	7020.2
30	172.7	430	3548.5	780	7128.1
40	234.7	440	3645.5	790	7236.3
50	298.6	450	3742.7	800	7344.9
60	364.6	460	3840.3	810	7453.7
70	432.3	470	3938.2	820	7562.9
80	501.7	480	4036.4	830	7672.4
90	572.8	490	4134.8	840	7782.3
100	645.3	500	4233.6	850	7892.5
110	719.4	510	4332.7	860	8003.0
120	794.8	520	4432.0	870	8113.8
130	871.5	530	4531.6	880	8225.0
140	949.5	540	4631.6	890	8336.5
150	1028.7	550	4731.8	900	8448.3
160	1108.9	560	4832.3	910	8560.5
170	1190.2	570	4933.1	920	8673.0
180	1272.6	580	5034.2	930	8785.8
190	1355.8	590	5135.6	940	8898.9
200	1440.0	600	5237.3	950	9012.4
210	1525.0	610	5339.4	960	9126.2
220	1610.9	620	5441.7	970	9240.3
230	1697.5	630	5544.5	980	9354.8
240	1784.9	640	5647.7	990	9469.6
250	1872.9	650	5751.3	1000	9584.7
260	1961.7	660	5855.3	1010	9700.2
270	2051.0	670	5959.5	1020	9815.9
280	2141.0	680	6064.1	1030	9932.0
290	2231.6	690	6169.0	1040	10048.5
300	2322.7			1050	10165.2
310	2414.3			1060	10282.3
320	2506.5			1070	10399.7
330	2599.1			1080	10517.4
340	2692.2			1090	10635.4

APPENDIX G (cont.) TYPE S MICROVOLTS AT EACH 10 DEGREES CELSIUS

TEMP	μVOLT	TEMP	μVOLT
1100	10753.6	1500	15576.5
1110	10872.0	1510	15696.7
1120	10990.7	1520	15816.8
1130	11109.5	1530	15936.8
1140	11228.6	1540	16056.6
1150	11347.9	1550	16176.2
1160	11467.4	1560	16295.6
1170	11587.1	1570	16414.8
1180	11706.9	1580	16533.8
1190	11826.9	1590	16652.6
1200	11947.1	1600	16771.2
1210	12067.4	1610	16889.5
1220	12187.8	1620	17007.6
1230	12308.4	1630	17125.5
1240	12429.0	1640	17243.1
1250	12549.8	1650	17360.4
1260	12670.7	1660	17477.4
1270	12791.7	1670	17594.2
1280	12912.7	1680	17710.5
1290	13033.8	1690	17826.4
1300	13155.0	1700	17941.7
1310	13276.2	1710	18056.2
1320	13397.5	1720	18169.8
1330	13518.8	1730	18282.3
1340	13640.1	1740	18393.7
1350	13761.4	1750	18503.8
1360	13882.8	1760	18612.4
1370	14004.1		
1380	14125.4		
1390	14246.7		
1400	14368.0		
1410	14489.2		
1420	14610.3		
1430	14731.4		
1440	14852.4		
1450	14973.4		
1460	15094.2		
1470	15215.0		
1480	15335.6		
1490	15456.1		

APPENDIX H TYPE B MICROVOLTS AT EACH 10 DEGREES CELSIUS

(Designed for negligible cold-junction voltage at room temperatures so that no compensation is required, Type B temperatures are displayed by the meter only above 100 degrees C (33 microvolts)).

TEMP	μ VOLT	TEMP	μ VOLT	TEMP	μ VOLT
100	33.2	450	1001.8	800	3154.0
110	42.7	460	1047.8	810	3230.8
120	53.4	470	1094.8	820	3308.4
130	65.2	480	1142.7	830	3386.7
140	78.0	490	1191.6	840	3465.8
150	92.0	500	1241.5	850	3545.7
160	107.1	510	1292.3	860	3626.4
170	123.2	520	1344.0	870	3707.8
180	140.5	530	1396.7	880	3790.0
190	158.8	540	1450.3	890	3872.9
200	178.2	550	1504.8	900	3956.5
210	198.7	560	1560.3	910	4040.9
220	220.2	570	1616.6	920	4126.0
230	242.8	580	1673.9	930	4211.9
240	266.5	590	1732.1	940	4298.4
250	291.2	600	1791.2	950	4385.7
260	317.0	610	1851.2	960	4473.7
270	343.8	620	1912.1	970	4562.4
280	371.7	630	1973.8	980	4651.8
290	400.6	640	2036.5	990	4741.9
300	430.5	650	2100.0	1000	4832.6
310	461.5	660	2164.4	1010	4924.1
320	493.5	670	2229.6	1020	5016.2
330	526.6	680	2295.7	1030	5109.0
340	560.7	690	2362.7	1040	5202.5
350	595.8	700	2430.5	1050	5296.6
360	631.9	710	2499.1	1060	5391.4
370	669.0	720	2568.6	1070	5486.8
380	707.1	730	2639.0	1080	5582.9
390	746.2	740	2710.1	1090	5679.6
400	786.4	750	2782.1	1100	5776.9
410	827.5	760	2854.8	1110	5874.9
420	869.6	770	2928.4	1120	5973.4
430	912.7	780	3002.8	1130	6072.6
440	956.7	790	3078.0	1140	6172.4

APPENDIX H (cont.) TYPE B MICROVOLTS AT EACH 10 DEGREES CELSIUS

TEMP	μ VOLT	TEMP	μ VOLT
1150	6272.8	1500	10094.0
1160	6373.7	1510	10209.7
1170	6475.3	1520	10325.5
1180	6577.4	1530	10441.5
1190	6680.1	1540	10557.7
1200	6783.3	1550	10674.0
1210	6887.1	1560	10790.5
1220	6991.4	1570	10907.1
1230	7096.3	1580	11023.7
1240	7201.7	1590	11140.5
1250	7307.6	1600	11257.4
1260	7414.0	1610	11374.3
1270	7521.0	1620	11491.3
1280	7628.4	1630	11608.2
1290	7736.3	1640	11725.2
1300	7844.6	1650	11842.2
1310	7953.4	1660	11959.1
1320	8062.7	1670	12076.1
1330	8172.4	1680	12192.9
1340	8282.6	1690	12309.7
1350	8393.2	1700	12426.3
1360	8504.1	1710	12542.9
1370	8615.5	1720	12659.4
1380	8727.3	1730	12775.7
1390	8839.4	1740	12891.8
1400	8951.9	1750	13007.8
1410	9064.8	1760	13123.6
1420	9178.0	1770	13239.1
1430	9291.5	1780	13354.5
1440	9405.3	1790	13469.6
1450	9519.4	1800	13584.5
1460	9633.8	1810	13699.1
1470	9748.5	1820	13813.5
1480	9863.4		
1490	9978.6		

APPENDIX I

DIN TYPE J MICROVOLTS AT EACH 10 DEGREES CELSIUS

(From DIN 43710, with smoothing added)

TEMP	μVOLT	TEMP	μVOLT	TEMP	μVOLT
-200	-8150.0	200	10950.0	600	33670.2
-190	-7858.0	210	11510.0	610	34259.8
-180	-7557.0	220	12069.8	620	34851.5
-170	-7247.7	230	12627.9	630	35444.7
-160	-6929.0	240	13187.5	640	36039.4
-150	-6596.5	250	13749.6	650	36637.7
-140	-6252.5	260	14314.1	660	37241.8
-130	-5898.8	270	14877.3	670	37853.2
-120	-5533.2	280	15439.1	680	38473.0
-110	-5148.9	290	15999.8	690	39096.0
-100	-4744.8	300	16560.0	700	39719.3
-90	-4321.5	310	17120.1	710	40346.6
-80	-3885.2	320	17680.0	720	40982.8
-70	-3437.9	330	18240.0	730	41625.0
-60	-2982.7	340	18800.0	740	42271.5
-50	-2511.9	350	19360.1	750	42921.6
-40	-2026.2	360	19920.9	760	43574.1
-30	-1527.3	370	20481.1	770	4229.3
-20	-1024.2	380	21039.9	780	44887.7
-10	-515.4	390	21597.3	790	45550.1
0	0	400	22157.8	800	46220.0
10	521.0	410	22722.1	810	46891.3
20	1046.6	420	23290.2	820	47570.0
30	1577.7	430	23859.5	830	48252.0
40	2113.5	440	24429.4	840	48940.5
50	2650.4	450	25000.7	850	49630.4
60	3188.0	460	25571.0	860	50322.8
70	3728.5	470	26140.0	870	51020.0
80	4272.1	480	26707.5	880	51722.9
90	4817.9	490	27278.2	890	52430.5
100	5365.4	500	27852.8	900	53140.0
110	5917.0	510	28430.6		
120	6472.2	520	29010.0		
130	7030.5	530	29589.8		
140	7589.9	540	30170.1		
150	8149.8	550	30748.8		
160	8709.9	560	31327.3		
170	9269.9	570	31908.4		
180	9830.0	580	32494.1		
190	10390.0	590	33081.8		

APPENDIX J - DIN 43760 RTD (ALPHA = 0.00385) OHMS AT EACH 10 DEGREES CELSIUS

TEMP	OHMS	TEMP	OHMS	TEMP	OHMS
-200	18.493	150	157.315	500	280.896
-190	22.803	160	161.043	510	284.218
-180	27.078	170	164.760	520	287.529
-170	31.320	180	168.465	530	290.827
-160	35.531	190	172.158	540	294.115
-150	39.714	200	175.840	550	297.390
-140	43.869	210	179.510	560	300.654
-130	47.999	220	183.168	570	303.907
-120	52.106	230	186.815	580	307.147
-110	56.190	240	190.451	590	310.377
-100	60.254	250	194.074	600	313.594
-90	64.299	260	197.686	610	316.800
-80	68.325	270	201.287	620	319.995
-70	72.335	280	204.876	630	323.177
-60	76.328	290	208.453	640	326.349
-50	80.307	300	212.019	650	329.508
-40	84.271	310	215.573	660	332.656
-30	88.222	320	219.115	670	335.792
-20	92.160	330	222.646	680	338.917
-10	96.086	340	226.166	690	342.030
0	100.000	350	229.673	700	345.132
10	103.902	360	233.169	710	348.222
20	107.793	370	236.654	720	351.300
30	111.672	380	240.127	730	354.367
40	115.539	390	243.588	740	357.422
50	119.395	400	247.038	750	360.466
60	123.239	410	250.476	760	363.497
70	127.072	420	253.902	770	366.518
80	130.893	430	257.317	780	369.527
90	134.702	440	260.720	790	372.524
100	138.500	450	264.112	800	375.509
110	142.286	460	267.492	810	378.483
120	146.061	470	270.860	820	381.445
130	149.824	480	274.217	830	384.396
140	153.575	490	277.563	840	387.335
				850	390.263

APPENDIX K - NIST PT-100 (ALPHA = 0.00392) OHMS AT EACH 10 DEGREES CELSIUS

TEMP	OHMS	TEMP	OHMS	TEMP	OHMS
-200	16.919	150	158.451	500	284.557
-190	21.310	160	162.254	510	287.949
-180	25.666	170	166.045	520	291.329
-170	29.988	180	169.824	530	294.697
-160	34.280	190	173.592	540	298.053
-150	38.542	200	177.347	550	301.398
-140	42.777	210	181.091	560	304.731
-130	46.987	220	184.824	570	308.052
-120	51.172	230	188.544	580	311.361
-110	55.335	240	192.253	590	314.659
-100	59.478	250	195.950	600	317.945
-90	63.601	260	199.635	610	321.219
-80	67.706	270	203.309	620	324.481
-70	71.793	280	206.971	630	327.732
-60	75.865	290	210.621	640	330.970
-50	79.921	300	214.259	650	334.198
-40	83.963	310	217.885	660	337.413
-30	87.991	320	221.500	670	340.617
-20	92.006	330	225.103	680	343.808
-10	96.009	340	228.700	690	346.989
0	100.000	350	232.274	700	350.157
10	103.979	360	235.842	710	353.314
20	107.946	370	239.398	720	356.458
30	111.902	380	242.942	730	359.591
40	115.845	390	246.475	740	362.713
50	119.777	400	249.996	750	365.823
60	123.698	410	253.505	760	368.920
70	127.606	420	257.002	770	372.007
80	131.503	430	260.488	780	375.081
90	135.388	440	263.961	790	378.143
100	139.261	450	267.423	800	381.194
110	143.123	460	270.874	810	384.234
120	146.972	470	274.312	820	387.261
130	150.810	480	277.739	830	390.277
140	154.637	490	281.154	840	393.280
				850	396.273

22. Temperature Conversion Chart

to F°	From	to C°	to F°	From	to C°	to F°	From	to C°
—	-458	-272.22	—	-378	-227.78	—	-298	-183.33
—	-456	-271.11	—	-376	-226.67	—	-296	-182.22
—	-454	-270.00	—	-374	-225.56	—	-294	-181.11
—	-452	-268.89	—	-372	-224.44	—	-292	-180.00
—	-450	-267.78	—	-370	-223.33	—	-290	-178.89
—	-448	-266.67	—	-368	-222.22	—	-288	-177.78
—	-446	-265.56	—	-366	-221.11	—	-286	-176.67
—	-444	-264.44	—	-364	-220.00	—	-284	-175.56
—	-442	-263.33	—	-362	-218.89	—	-282	-174.44
—	-440	-262.22	—	-360	-217.78	—	-280	-173.33
—	-438	-261.11	—	-358	-216.67	—	-278	-172.22
—	-436	-260.00	—	-356	-215.56	—	-276	-171.11
—	-434	-258.89	—	-354	-214.44	—	-274	-170.00
—	-432	-257.78	—	-352	-213.33	-457.6	-272	-168.89
—	-430	-256.67	—	-350	-212.22	-454.0	-270	-167.78
—	-428	-255.56	—	-348	-211.11	-450.4	-268	-166.67
—	-426	-254.44	—	-346	-210.00	-446.8	-266	-165.56
—	-424	-253.33	—	-344	-208.89	-443.2	-264	-164.44
—	-422	-252.22	—	-342	-207.78	-439.6	-262	-163.33
—	-420	-251.11	—	-340	-206.67	-436.0	-260	-162.22
—	-418	-250.00	—	-338	-205.56	-432.4	-258	-161.11
—	-416	-248.89	—	-336	-204.44	-428.8	-256	-160.00
—	-414	-247.78	—	-334	-203.33	-425.2	-254	-158.89
—	-412	-246.67	—	-332	-202.22	-421.6	-252	-157.78
—	-410	-245.56	—	-330	-201.11	-418.0	-250	-156.67
—	-408	-244.44	—	-328	-200.00	-414.4	-248	-155.56
—	-406	-243.33	—	-326	-198.89	-410.8	-246	-154.44
—	-404	-242.22	—	-324	-197.78	-407.2	-244	-153.33
—	-402	-241.11	—	-322	-196.67	-403.6	-242	-152.22
—	-400	-240.00	—	-320	-195.56	-400.0	-240	-151.11
—	-398	-238.89	—	-318	-194.44	-396.4	-238	-150.00
—	-396	-237.78	—	-316	-193.33	-392.8	-236	-148.89
—	-394	-236.67	—	-314	-192.22	-389.2	-234	-147.78
—	-392	-235.56	—	-312	-191.11	-385.6	-232	-146.67
—	-390	-234.44	—	-310	-190.00	-382.0	-230	-145.56
—	-388	-233.33	—	-308	-188.89	-378.4	-228	-144.44
—	-386	-232.22	—	-306	-187.78	-374.8	-226	-143.33
—	-384	-231.11	—	-304	-186.67	-371.2	-224	-142.22
—	-382	-230.00	—	-302	-185.56	-367.6	-222	-141.11
—	-380	-228.89	—	-300	-184.44	-364.0	-220	-140.00

to F°	From	to C°	to F°	From	to C°	to F°	From	to C°
-360.4	-218	-138.89	-216.4	-138	-94.44	-72.4	-58	-50.00
-356.8	-216	-137.78	-212.8	-136	-93.33	-68.8	-56	-48.89
-353.2	-214	-136.67	-209.2	-134	-92.22	-65.2	-54	-47.78
-349.6	-212	-135.56	-205.6	-132	-91.11	-61.6	-52	-46.67
-346.0	-210	-134.44	-202.0	-130	-90.00	-58.0	-50	-45.56
-360.4	-208	-133.33	-198.4	-128	-88.89	-54.4	-48	-44.44
-356.8	-206	-132.22	-194.8	-126	-87.78	-50.8	-46	-43.33
-353.2	-204	-131.11	-191.2	-124	-86.67	-47.2	-44	-42.22
-349.6	-202	-130.00	-187.6	-122	-85.56	-43.6	-42	-41.11
-346.0	-200	-128.89	-184.0	-120	-84.44	-40.0	-40	-40.00
-324.4	-198	-127.78	-180.4	-118	-83.33	-36.4	-38	-38.89
-320.8	-196	-126.67	-176.8	-116	-82.22	-32.8	-36	-37.78
-317.2	-194	-125.56	-173.2	-114	-81.11	-29.2	-34	-36.67
-313.6	-192	-124.44	-169.6	-112	-80.00	-25.6	-32	-35.56
-310.0	-190	-123.33	-166.0	-110	-78.89	-22.0	-30	-34.44
-306.4	-188	-122.22	-162.4	-108	-77.78	-18.4	-28	-33.33
-302.8	-186	-121.11	-158.8	-106	-76.67	-14.8	-26	-32.22
-299.2	-184	-120.00	-155.2	-104	-75.56	-11.2	-24	-31.11
-295.6	-182	-118.89	-151.6	-102	-74.44	-7.6	-22	-30.00
-292.0	-180	-117.78	-148.0	-100	-73.33	-4.0	-20	-28.89
-288.4	-178	-116.67	-144.4	-98	-72.22	-0.4	-18	-27.78
-284.8	-176	-115.56	-140.8	-96	-71.11	+3.2	-16	-26.67
-281.2	-174	-114.44	-137.2	-94	-70.00	+6.8	-14	-25.56
-277.6	-172	-113.33	-133.6	-92	-68.89	+10.4	-12	-24.44
-274.0	-170	-112.22	-130.0	-90	-67.78	+14.0	-10	-23.33
-270.4	-168	-111.11	-126.4	-88	-66.67	+17.6	-8	-22.22
-266.8	-166	-110.00	-122.8	-86	-65.56	+21.2	-6	-21.11
-263.2	-164	-108.89	-119.2	-84	-64.44	+24.8	-4	-20.00
-259.6	-162	-107.78	-115.6	-82	-63.33	+28.4	-2	-18.89
-256.0	-160	-106.67	-112.0	-80	-62.22	+32.0	0	-17.78
-252.4	-158	-105.56	-108.4	-78	-61.11	+35.6	+2	-16.67
-248.8	-156	-104.44	-104.8	-76	-60.00	+39.2	+4	-15.56
-245.2	-154	-103.33	-101.2	-74	-58.89	+42.8	+6	-14.44
-241.6	-152	-102.22	-97.6	-72	-57.78	+46.4	+8	-13.33
-238.0	-150	-101.11	-94.0	-70	-56.67	+50.0	+10	-12.22
-234.4	-148	-100.00	-90.4	-68	-55.56	+53.6	+12	-11.11
-230.8	-146	-98.89	-86.8	-66	-54.44	+57.2	+14	-10.00
-227.2	-144	-97.78	-83.2	-64	-53.33	+60.8	+16	-8.89
-223.6	-142	-96.67	-79.6	-62	-52.22	+64.4	+18	-7.78
-220.0	-140	-95.56	-76.0	-60	-51.11	+66.0	+20	-6.67

to F°	From	to C°	to F°	From	to C°	to F°	From	to C°
+71.6	+22	-5.56	215.6	102	38.89	359.6	182	83.33
+75.2	+24	-4.44	219.2	104	40.00	363.2	184	84.44
+78.8	+26	-3.33	222.8	106	41.11	366.8	186	85.56
+82.4	+28	-2.22	226.4	108	42.22	370.4	188	86.67
+86.0	+30	-1.11	230.0	110	43.33	374.0	190	87.78
+89.6	+32	0.00	233.6	112	44.44	377.6	192	88.89
+93.2	+34	+1.11	237.2	114	45.56	381.2	194	90.00
+96.8	+36	+2.22	240.8	116	46.67	384.8	196	91.11
+100.4	+38	+3.33	244.4	118	47.78	388.4	198	92.22
+104.0	+40	+4.44	248.0	120	48.89	392.0	200	93.33
107.6	42	5.56	251.6	122	50.00	395.6	202	94.44
111.2	44	6.67	255.2	124	51.11	399.2	204	95.56
114.2	46	7.78	258.8	126	52.22	402.8	206	96.67
118.4	48	8.89	262.4	128	53.33	406.4	208	97.78
122.0	50	10.00	266.0	130	54.44	410.0	210	98.89
125.6	52	11.11	269.6	132	55.56	413.6	212	100.00
129.2	54	12.22	273.2	134	56.67	417.2	214	101.11
132.8	56	13.33	276.8	136	57.78	420.8	216	102.22
136.4	58	14.44	280.4	138	58.89	424.4	218	103.33
140.0	60	15.56	284.0	140	60.00	428.0	220	104.44
143.6	62	16.67	287.6	142	61.11	431.6	222	105.56
147.2	64	17.78	291.2	144	62.22	435.2	224	106.67
150.8	66	18.89	294.8	146	63.33	438.8	226	107.78
154.4	68	20.00	298.4	148	64.44	442.4	228	108.89
158.0	70	21.11	302.0	150	65.56	446.0	230	110.00
161.6	72	22.22	305.6	152	66.67	449.6	232	111.11
165.2	74	23.33	309.2	154	67.78	453.2	234	112.22
168.8	76	24.44	312.8	156	68.89	456.8	236	113.33
172.4	78	25.56	316.4	158	70.00	460.4	238	114.44
176.0	80	26.67	320.0	160	71.11	464.0	240	115.56
179.6	82	27.78	323.6	162	72.22	467.6	242	116.67
183.2	84	28.89	327.2	164	73.33	471.2	244	117.78
186.8	86	30.00	330.8	166	74.44	474.8	246	118.89
190.4	88	31.11	334.4	168	75.56	478.4	248	120.00
194.0	90	32.22	338.0	170	76.67	482.0	250	121.11
197.6	92	33.33	341.6	172	77.78	485.6	252	122.22
201.2	94	34.44	345.2	174	78.89	489.2	254	123.33
204.8	96	35.56	348.8	176	80.00	492.8	256	124.44
208.4	98	36.67	352.4	178	81.11	496.4	258	125.56
212.0	100	37.78	356.0	180	82.22	500.0	260	126.67

to F°	From	to C°	to F°	From	to C°	to F°	From	to C°
503.6	262	127.78	647.6	342	172.22	791.6	422	216.67
507.2	264	128.89	651.2	344	173.33	795.2	424	217.78
510.8	266	130.00	654.8	346	174.44	798.8	426	218.89
514.4	268	131.11	658.4	348	175.56	802.4	428	220.00
518.0	270	132.22	662.0	350	176.67	806.0	430	221.11
521.6	272	133.33	665.6	352	177.78	809.6	432	222.22
525.2	274	134.44	669.2	354	178.89	813.2	434	223.33
528.8	276	135.56	672.8	356	180.00	816.8	436	224.44
532.4	278	136.67	676.4	358	181.11	820.4	438	225.56
536.0	280	137.78	680.0	360	182.22	824.0	440	226.67
539.6	282	138.89	683.6	362	183.33	827.6	442	227.78
543.2	284	140.00	667.2	364	184.44	831.2	444	228.89
546.8	286	141.11	690.8	366	185.56	834.8	446	230.00
550.4	288	142.22	694.4	368	186.67	838.4	448	231.11
554.0	290	143.33	698.0	370	187.78	842.0	450	232.22
557.6	292	144.44	701.6	372	188.89	845.6	452	233.33
561.2	294	145.56	705.2	374	190.00	849.2	454	234.44
564.8	296	146.67	708.8	376	191.11	852.8	456	235.56
568.4	298	147.78	712.4	378	192.22	856.4	458	236.67
572.0	300	148.89	716.0	380	193.33	860.0	460	237.78
575.6	302	150.00	719.6	382	194.44	863.6	462	238.89
579.2	304	151.11	723.2	384	195.56	867.2	464	240.00
582.8	306	152.22	726.8	386	196.67	870.8	466	241.11
586.4	308	153.33	730.4	388	197.78	874.4	468	242.22
590.0	310	154.44	734.0	390	198.89	878.0	470	243.33
593.6	312	155.56	737.6	392	200.00	881.6	472	244.44
597.2	314	156.67	741.2	394	201.11	885.2	474	245.56
600.8	316	157.78	744.8	396	202.22	888.8	476	246.67
604.4	318	158.89	748.4	398	203.33	892.4	478	247.78
608.0	320	160.00	752.0	400	204.44	896.0	480	248.89
611.6	322	161.11	755.6	402	205.56	899.6	482	250.00
615.2	324	162.22	759.2	404	206.67	903.2	484	251.11
618.8	326	163.33	762.8	406	207.78	906.8	486	252.22
622.4	328	164.44	766.4	408	208.89	910.4	488	253.33
626.0	330	165.56	770.0	410	210.00	914.0	490	254.44
629.6	332	166.67	773.6	412	211.11	917.6	492	255.56
633.2	334	167.78	777.2	414	212.22	921.2	494	256.67
636.8	336	168.89	780.8	416	213.33	924.8	496	257.78
640.4	338	170.00	784.4	418	214.44	928.4	498	258.89
644.0	340	171.11	788.0	420	215.56	932.0	500	260.00

to F°	From	to C°	to F°	From	to C°	to F°	From	to C°
935.6	502	261.11	1310.0	710	376.67	2030.0	1110	598.89
939.2	504	262.22	1328.0	720	382.22	2048.0	1120	604.44
942.8	506	263.33	1346.0	730	387.78	2066.0	1130	610.00
946.4	508	264.44	1364.0	740	393.33	2084.0	1140	615.56
950.0	510	265.56	1382.0	750	398.89	2102.0	1150	621.11
953.6	512	266.67	1400.0	760	404.44	2120.0	1160	626.67
957.2	514	267.78	1418.0	770	410.00	2138.0	1170	632.22
960.8	516	268.89	1436.0	780	415.56	2156.0	1180	637.78
964.4	518	270.00	1454.0	790	421.11	2174.0	1190	643.33
968.0	520	271.11	1472.0	800	426.67	2192.0	1200	648.89
971.6	522	272.22	1490.0	810	432.22	2210.0	1210	654.44
975.2	524	273.33	1508.0	820	437.78	2228.0	1220	660.00
978.8	526	274.44	1526.0	830	443.33	2246.0	1230	665.56
982.4	528	275.56	1544.0	840	448.89	2264.0	1240	671.11
986.0	530	276.67	1562.0	850	454.44	2282.0	1250	676.67
989.6	532	277.78	1580.0	860	460.00	2300.0	1260	682.22
993.2	534	278.89	1598.0	870	465.56	2318.0	1270	687.78
996.8	536	280.00	1616.0	880	471.11	2336.0	1280	693.33
1000.4	538	281.11	1634.0	890	476.67	2354.0	1290	698.89
1004.0	540	282.22	1652.0	900	482.22	2372.0	1300	704.44
1007.6	542	283.33	1670.0	910	487.78	2390.0	1310	710.00
1011.2	544	284.44	1688.0	920	493.33	2408.0	1320	715.56
1014.8	546	285.56	1706.0	930	498.89	2426.0	1330	721.11
1018.4	548	286.67	1724.0	940	504.44	2444.0	1340	726.67
1022.0	550	287.78	1742.0	950	510.00	2462.0	1350	732.22
1040.0	560	293.33	1760.0	960	515.56	2480.0	1360	737.78
1058.0	570	298.89	1778.0	970	521.11	2498.0	1370	743.33
1076.0	580	304.44	1796.0	980	526.67	2516.0	1380	748.89
1094.0	590	310.00	1814.0	990	532.22	2534.0	1390	754.44
1112.0	600	315.56	1832.0	1000	537.78	2552.0	1400	760.00
1130.0	610	321.11	1850.0	1010	543.33	2570.0	1410	765.56
1148.0	620	326.67	1868.0	1020	548.89	2588.0	1420	771.11
1166.0	630	332.22	1886.0	1030	554.44	2606.0	1430	776.67
1184.0	640	337.78	1904.0	1040	560.00	2624.0	1440	782.22
1202.0	650	343.33	1922.0	1050	565.56	2642.0	1450	787.78
1220.0	660	348.89	1940.0	1060	571.11	2660.0	1460	793.33
1238.0	670	354.44	1958.0	1070	576.67	2678.0	1470	798.89
1256.0	680	360.00	1976.0	1080	582.22	2696.0	1480	804.44
1274.0	690	365.56	1994.0	1090	587.78	2714.0	1490	810.00
1292.0	700	371.11	2012.0	1100	593.33	2732.0	1500	815.56

to F°	From	to C°	to F°	From	to C°	to F°	From	to C°
2750.0	1510	821.11	3470.0	1910	1043.3	4190.0	2310	1265.6
2768.0	1520	826.67	3488.0	1920	1048.9	4208.0	2320	1271.1
2786.0	1530	832.22	3506.0	1930	1054.4	4226.0	2330	1276.7
2804.0	1540	837.78	3524.0	1940	1060.0	4244.0	2340	1282.2
2822.0	1550	843.33	3542.0	1950	1065.6	4262.0	2350	1287.8
2840.0	1560	848.89	3560.0	1960	1071.1	4280.0	2360	1293.3
2858.0	1570	854.44	3578.0	1970	1076.7	4298.0	2370	1298.9
2876.0	1580	860.00	3596.0	1980	1082.2	4316.0	2380	1304.4
2894.0	1590	865.56	3614.0	1990	1087.8	4334.0	2390	1310.0
2912.0	1600	871.11	3632.0	2000	1093.3	4352.0	2400	1315.6
2930.0	1610	876.67	3650.0	2010	1098.9	4370.0	2410	1321.1
2948.0	1620	882.22	3668.0	2020	1104.4	4388.0	2420	1326.7
2966.0	1630	887.78	3686.0	2030	1110.0	4406.0	2430	1332.2
2984.0	1640	893.33	3704.0	2040	1115.6	4424.0	2440	1337.8
3002.0	1650	898.89	3722.0	2050	1121.1	4442.0	2450	1343.3
3020.0	1660	904.44	3740.0	2060	1126.7	4460.0	2460	1348.9
3038.0	1670	910.00	3758.0	2070	1132.2	4478.0	2470	1354.4
3056.0	1680	915.56	3776.0	2080	1137.8	4496.0	2480	1360.0
3074.0	1690	921.11	3794.0	2090	1143.3	4514.0	2490	1365.6
3092.0	1700	926.67	3812.0	2100	1148.9	4532.0	2500	1371.1
3110.0	1710	932.22	3830.0	2110	1154.4	4550.0	2510	1376.7
3128.0	1720	937.78	3848.0	2120	1160.0	4568.0	2520	1382.2
3146.0	1730	943.33	3866.0	2130	1165.6	4586.0	2530	1387.8
3164.0	1740	948.89	3884.0	2140	1171.1	4604.0	2540	1393.3
3182.0	1750	954.44	3902.0	2150	1176.7	4622.0	2550	1398.9
3200.0	1760	960.00	3920.0	2160	1182.2	4640.0	2560	1404.4
3218.0	1770	965.56	3938.0	2170	1187.8	4658.0	2570	1410.0
3236.0	1780	971.11	3956.0	2180	1193.3	4676.0	2580	1415.6
3254.0	1790	976.67	3974.0	2190	1198.9	4694.0	2590	1421.1
3272.0	1800	982.22	3992.0	2200	1204.4	4712.0	2600	1426.7
3290.0	1810	987.78	4010.0	2210	1210.0	4730.0	2610	1432.2
3308.0	1820	993.33	4028.0	2220	1215.6	4748.0	2620	1437.8
3326.0	1830	998.89	4046.0	2230	1221.1	4766.0	2630	1443.3
3344.0	1840	1004.4	4064.0	2240	1226.7	4784.0	2640	1448.9
3362.0	1850	1010.0	4082.0	2250	1232.2	4802.0	2650	1454.4
3380.0	1860	1015.6	4100.0	2260	1237.8	4820.0	2660	1460.0
3398.0	1870	1021.1	4118.0	2270	1243.3	4838.0	2670	1465.6
3416.0	1880	1026.7	4136.0	2280	1248.9	4856.0	2680	1471.1
3434.0	1890	1032.2	4154.0	2290	1254.4	4874.0	2690	1467.7
3452.0	1900	1037.8	4172.0	2300	1260.0	4892.0	2700	1482.2

to F°	From	to C°	to F°	From	to C°	to F°	From	to C°
4910.0	2710	1487.8	5702.0	3150	1732.2	9302.0	5150	2843.3
4928.0	2720	1493.3	5792.0	3200	1760.0	9392.0	5200	2871.1
4946.0	2730	1498.9	5882.0	3250	1787.8	9482.0	5250	2898.9
4964.0	2740	1504.4	5972.0	3300	1815.6	9572.0	5300	2926.7
4982.0	2750	1510.0	6062.0	3350	1843.3	9662.0	5350	2954.4
5000.0	2760	1515.6	6152.0	3400	1871.1	9752.0	5400	2982.2
5018.0	2770	1521.1	6242.0	3450	1898.9	9842.0	5450	3010.0
5036.0	2780	1526.7	6332.0	3500	1926.7	9932.0	5500	3037.8
5054.0	2790	1532.2	6422.0	3550	1954.4	10,002.0	5550	3065.6
5072.0	2800	1537.8	6512.0	3600	1982.2	10,112.0	5600	3093.3
5090.0	2810	1543.3	6602.0	3650	2010.0			
5108.0	2820	1548.9	6692.0	3700	2037.8			
5126.0	2830	1554.4	6782.0	3750	2065.6			
5144.0	2840	1560.0	6872.0	3800	2093.3			
5162.0	2850	1565.6	6962.0	3850	2121.1			
5180.0	2860	1571.1	7052.0	3900	2148.9			
5198.0	2870	1576.7	7142.0	3950	2176.7			
5216.0	2880	1582.2	7232.0	4000	2204.4			
5234.0	2890	1587.8	7322.0	4050	2232.2			
5252.0	2900	1593.3	7412.0	4100	2260.0			
5270.0	2910	1598.9	7502.0	4150	2287.8			
5288.0	2920	1604.4	7592.0	4200	2315.6			
5306.0	2930	1610.0	7682.0	4250	2343.3			
5324.0	2940	1615.6	7772.0	4300	2371.1			
5342.0	2950	1621.1	7862.0	4350	2398.9			
5360.0	2960	1626.7	7952.0	4400	2426.7			
5378.0	2970	1632.2	8042.0	4450	2454.4			
5396.0	2980	1637.8	8132.0	4500	2482.2			
5414.0	2990	1643.3	8222.0	4550	2510.0			
5432.0	3000	1648.9	8312.0	4600	2537.8			
5450.0	3010	1654.4	8402.0	4650	2565.6			
5468.0	3020	1660.0	8492.0	4700	2593.3			
5486.0	3030	1665.6	8582.0	4750	2621.1			
5504.0	3040	1671.1	8672.0	4800	2648.9			
5522.0	3050	1676.7	8762.0	4850	2676.7			
5540.0	3060	1682.2	8852.0	4900	2704.4			
5558.0	3070	1687.8	8942.0	4950	2732.2			
5576.0	3080	1693.3	9032.0	5000	2760.0			
5594.0	3090	1698.9	9122.0	5050	2787.8			
5612.0	3100	1704.4	9212.0	5100	2815.6			

Warranty/Disclaimer

NEWPORT Electronics, Inc. warrants this unit to be free of defects in materials and workmanship for a period of one (1) year from the date of purchase. In addition to NEWPORT's standard warranty period, NEWPORT Electronics will extend the warranty period for one (1) additional year if the warranty card enclosed with each instrument is returned to NEWPORT.

If the unit should malfunction, it must be returned to the factory for evaluation. NEWPORT's Customer Service Department will issue an Authorized Return (AR) number immediately upon phone or written request. Upon examination by NEWPORT, if the unit is found to be defective it will be repaired or replaced at no charge. NEWPORT's WARRANTY does not apply to defects resulting from any action of the purchaser, including but not limited to mishandling, improper interfacing, operation outside of design limits, improper repair, or unauthorized modification. This WARRANTY is VOID if the unit shows evidence of having been tampered with or shows evidence of being damaged as a result of excessive corrosion; or current, heat, moisture or vibration; improper specification; misapplication; misuse or other operating conditions outside of NEWPORT's control. Components which wear are not warranted, including but not limited to contact points, fuses, and triacs.

NEWPORT is pleased to offer suggestions on the use of its various products. However, NEWPORT neither assumes responsibility for any omissions or errors nor assumes liability for any damages that result from the use of its products in accordance with information provided by NEWPORT, either verbal or written. NEWPORT warrants only that the parts manufactured by it will be as specified and free of defects. NEWPORT MAKES NO OTHER WARRANTIES OR REPRESENTATIONS OF ANY KIND WHATSOEVER, EXPRESSED OR IMPLIED, EXCEPT THAT OF TITLE, AND ALL IMPLIED WARRANTIES INCLUDING ANY WARRANTY OF MERCHANTABILITY AND FITNESS FOR A PARTICULAR PURPOSE ARE HEREBY DISCLAIMED. LIMITATION OF LIABILITY: The remedies of purchaser set forth herein are exclusive and the total liability of NEWPORT with respect to this order, whether based on contract, warranty, negligence, indemnification, strict liability or otherwise, shall not exceed the purchase price of the component upon which liability is based. In no event shall NEWPORT be liable for consequential, incidental or special damages.

CONDITIONS: Equipment sold by NEWPORT is not intended to be used, nor shall it be used: (1) as a "Basic Component" under 10 CFR 21 (NRC), used in or with any nuclear installation or activity; or (2) in medical applications or used on humans. Should any Product(s) be used in or with any nuclear installation or activity, medical application, or used on humans, or misused in any way, NEWPORT assumes no responsibility as set forth in our basic WARRANTY / DISCLAIMER language, and additionally purchaser will indemnify NEWPORT and hold NEWPORT harmless from any liability or damage whatsoever arising out of the use of the Product(s) in such a manner.

Return Requests/Inquiries

Direct all warranty and repair requests/inquiries to the NEWPORT Customer Service Department. **BEFORE RETURNING ANY PRODUCT(S) TO NEWPORT, PURCHASER MUST OBTAIN AN AUTHORIZED RETURN (AR) NUMBER FROM NEWPORT'S CUSTOMER SERVICE DEPARTMENT (IN ORDER TO AVOID PROCESSING DELAYS).** The assigned AR number should then be marked on the outside of the return package and on any correspondence.

The purchaser is responsible for shipping charges, freight, insurance and proper packaging to prevent breakage in transit.

FOR **WARRANTY** RETURNS, please have the following information available BEFORE contacting NEWPORT:

1. P.O. number under which the product was PURCHASED,
2. Model and serial number of the product under warranty, and
3. Repair instructions and/or specific problems relative to the product.

FOR **NON-WARRANTY** REPAIRS, consult NEWPORT for current repair charges. Have the following information available BEFORE contacting NEWPORT:

1. P.O. number to cover the COST of the repair,
2. Model and serial number of product, and
3. Repair instructions and/or specific problems relative to the product.

NEWPORT's policy is to make running changes, not model changes, whenever an improvement is possible. This affords our customers the latest in technology and engineering.

NEWPORT is a registered trademark of NEWPORT ELECTRONICS, INC.

© Copyright 2002 NEWPORT ELECTRONICS, INC. All rights reserved. This document may not be copied, photocopied, reproduced, translated, or reduced to any electronic medium or machine-readable form, in whole or in part, without prior written consent of NEWPORT ELECTRONICS, INC.

For immediate technical or application assistance please call:

1-800-6397678[®]
1-800-NEWPORT

Newport Electronics, Inc.
2229 South Yale Street • Santa Ana, CA • 92704 • U.S.A.
TEL: (714) 540-4914 • FAX: (714) 546-3022
Toll Free: 1-800-639-7678 • <http://www.newportUS.com> • e-mail: info@newportUS.com
ISO 9001 Certified

Newport Technologies, Inc.
976 Bergar • Laval (Quebec) • H7L 5A1 • Canada
TEL: (514) 335-3183 • FAX: (514) 856-6886
Toll Free: 1-800-639-7678 • <http://www.newport.ca> • e-mail: sales@newport.ca

Newport Electronics, Ltd.
One Omega Drive • River Bend Technology Centre
Northbank, Irlam • Manchester M44 5BD • United Kingdom
Tel: +44 161 777 6611 • FAX: +44 161 777 6622
Toll Free: 0800 488 488 • <http://www.newportuk.co.uk> • e-mail: sales@newportuk.co.uk

Newport Electronics B.V.
Postbus 8034 • 1180 LA Amstelveen • The Netherlands
TEL: +31 20 3472121 • FAX: +31 20 6434643
Toll Free: 0800 0993344 • <http://www.newport.nl> • e-mail: sales@newport.nl

Newport Electronics spol s.r.o.
Rudé armády 1868, 733 01 Karviná 8 • Czech Republic
TEL: +420 69 6311899 • FAX: +420 69 6311114
Toll Free: 0800-1-66342 • <http://www.newport.cz> • e-mail: sales@newport.cz

Newport Electronics GmbH
Daimlerstrasse 26 • D-75392 Deckenpfronn • Germany
TEL: 49 7056 9398-0 • FAX: 49 7056 9398-29
Toll Free: 0800 / 6397678 • <http://www.newport.de> • e-mail: sales@newport.de

Newport Electronique S.A.R.L.
11, rue Jacques Cartier • 78280 Guyancourt • France
TEL: +33 1 61 37 29 00 • FAX: +33 1 30 57 54 27
Toll Free: 0800 466 342 • <http://www.newport.fr> • e-mail: sales@newport.fr

Mexico and Latin America
TEL: 001-800-826-6342 • FAX: 001 (203) 359-7807
En Español: 001 (203) 359-7803

NEWPORTnetSM On-Line Service www.newportUS.com
--

Internet e-mail info@newportUS.com
--