



IDP

INFINITY[®] D Process Meter

Operator's Manual



NEWPORT Electronics, Inc.

<http://www.newportUS.com/manuals>

Additional products from

NEWPORT Electronics, Inc.

Counters	Rate Meters
Frequency Meters	Timers
PID Controllers	Totalizers
Clock/Timers	Strain Gauge Meters
Printers	Voltmeters
Process Meters	Multimeters
On/Off Controllers	Soldering Iron Testers
Recorders	pH pens
Relative Humidity	pH Controllers
Transmitters	pH Electrodes
Thermocouples	RTDs
Thermistors	Thermowells
Wire	Flow Sensors

For Immediate Assistance
In the U.S.A. and Canada: 1-800-NEWPORT®
In Mexico: (95) 800-NEWPORTSM
Or call your local NEWPORT Office.

NEWPORTnetSM On-Line Service
<http://www.newportUS.com>

Internet e-mail
info@newportUS.com

It is the policy of NEWPORT to comply with all worldwide safety and EMC/EMI regulations that apply. NEWPORT is constantly pursuing certification of its products to the European New Approach Directives. NEWPORT will add the CE mark to every appropriate device upon certification.

The information contained in this document is believed to be correct but NEWPORT Electronics, Inc. accepts no liability for any errors it contains, and reserves the right to alter specifications without notice.

WARNING: These products are not designed for use in, and should not be used for, patient connected applications.

PATENT NOTICE: The "Meter Case Bezel Design" is a trademark of NEWPORT Electronics, Inc., registered in the U.S.. This product is covered by one or more of the following patents: U.S. Pat. No. Des. 336,895; 5,274,577 / CANADA 2052599; 2052600 / ITALY 1249456; 1250938 / FRANCE BREVET No. 91 12756 / SPAIN 2039150; 2048066 / UK PATENT No. GB2 249 837; GB2 248 954 / GERMANY DE 41 34398 C2. OTHER INTERNATIONAL PATENTS PENDING.



This device is marked with the international caution symbol. It is important to read the Setup Guide before installing or commissioning this device as it contains important information relating to safety and EMC.

PREFACE

MANUAL OBJECTIVES

This manual shows you how to set up and use the Programmable Process meter.

NOTES, WARNINGS and CAUTIONS

Information that is especially important to note is identified by three labels:

- **NOTE**
- **WARNING**
- **CAUTION**
- **IMPORTANT**



NOTE: provides you with information that is important to successfully setup and use of the Process meter.



CAUTION or WARNING: tells you about the risk of electric shock.



CAUTION, WARNING or IMPORTANT: tells you of circumstances or practices that can effect the meter's functionality and must refer to accompanying documents.

Table of Contents

Section	Page
SEC 1 INTRODUCTION	1
1.1 Unpacking	1
1.2 Safety Considerations	2
SEC 2 ABOUT THE METER.	3
2.1 Front of the Meter	3
2.2 Back of the Meter	5
2.3 Disassembly.	6
SEC 3 GETTING STARTED	7
3.1 Changing Configuration Jumpers	7
3.2 Mounting the Meter	8
3.3 Connecting Sensor Input	9
3.4 Connecting Main Power.	12
SEC 4 CONFIGURING THE METER	13
4.1 Selecting the Input Range	13
4.2 Selecting a Decimal Point Position.	14
4.3 Scaling the Meter.	14
4.3.1 Internal Scaling	15
4.3.2 Live Scaling	16
4.4 Changing the Meter's Calibration.	17
APPENDICES	
A Checking and Changing Main Board Power Jumpers	19
B Reference Tables	21
C Specifications.	23
D CE Information	25

List of Figures

Figures		Page
2-1	Front-Panel	3
2-2	Connectors (ac-Powered and dc-Powered)	5
2-3	dc-Power Connections	6
3-1	S1 - S4 Jumpers	8
3-2	Meter - Exploded View	8
3-3	Panel Cut-Out	9
3-4	3-Wire dc Voltage Input Connections with Internal Excitation	9
3-5	2-Wire dc Voltage Input Connections with External Excitation	10
3-6	4-20 mA Input Connections with External Excitation	10
3-7	4-20 mA Transmitter Hook-Up with Internal Excitation	11
3-8	dc Current Input Connections with Current Source	11
3-9	Main Power Connections ac	12
3-10	Main Power Connections dc	12
A-1	115Vac Jumper Wiring (default)	19
A-2	230 Vac Jumper Wiring	20
C-1	Meter Dimensions	24

List of Tables

Table		Page
2-1	Connector Description	5
3-1	S1 - S4 DIP Switches	7
3-2	ac Power Connections	12
4-1	Meter Calibration Table	18
B-1	Display Messages	21
B-2	Menu Configuration Displays	21
B-3	Run Mode Displays	22
B-4	Factory Preset Values	22

NOTES

SECTION 1. INTRODUCTION

1.1 UNPACKING

Remove the Packing List and verify that you have received all equipment. If there are any questions about the shipment, use the phone numbers listed on the back cover to contact the Customer Service Department nearest you.

Upon receipt of shipment, inspect the container and equipment for any signs of damage. Note any evidence of rough handling in transit. Immediately report any damage to the shipping agent.



The carrier will not honor any claims unless all shipping material is saved for their examination. After examining and removing contents, save packing material and carton in the event reshipment is necessary.

Verify that you receive the following items in the shipping box:

QTY	DESCRIPTION
1	Programmable indicator/controller with all applicable connectors attached.
1	Owner's Manual
1	Quick Start Manual



If you ordered any of the available options (except the “BL” blank Lens option), they will be shipped in a separate container to avoid any damage to your indicator/controller.

1.2 SAFETY CONSIDERATIONS



This device is marked with the **international caution symbol**. It is **important to read** this manual before installing or commissioning this device as it contains important information relating to **Safety and EMC** (Electromagnetic Compatibility).

This instrument is a **panel mount** device protected in accordance with EN 61010-1:2001, electrical safety requirements for electrical equipment for measurement, control and laboratory. Installation of this instrument should be done by qualified personnel. In order to ensure safe operation, the following instructions should be followed.



This instrument has **no power-on switch**. An external **switch or circuit-breaker** shall be included in the building installation as a disconnecting device. It shall be marked to indicate this function, and it shall be in close proximity to the equipment within easy reach of the operator. The switch or circuit-breaker shall not interrupt the Protective Conductor (Earth wire), and it shall meet the relevant requirements of IEC 947-1 and IEC 947-3 (International Electrotechnical Commission). The switch shall not be incorporated in the main supply cord.



Furthermore, to provide protection against **excessive energy** being drawn from the main supply in case of a fault in the equipment, an **overcurrent** protection device shall be installed.



Note

- Do not exceed voltage rating on the label located on the top of the instrument housing.
- Always disconnect power before changing signal and power connections.
- Do not use this instrument on a work bench without its case for safety reasons.
- Do not operate this instrument in flammable or explosive atmospheres.
- Do not expose this instrument to rain or moisture.
- Unit mounting should allow for adequate ventilation to ensure instrument does not exceed operating temperature rating.
- Use electrical wires with adequate size to handle mechanical strain and power requirements. Install without exposing bare wire outside the connector to minimize electrical shock hazards.

EMC Considerations

- Whenever EMC is an issue, always use shielded cables.
- Never run signal and power wires in the same conduit.
- Use signal wire connections with twisted-pair cables.
- Install Ferrite Bead(s) on signal wires close to the instrument if EMC problems persist.

Failure to follow all instructions and warnings may result in injury!

SECTION 2. ABOUT THE METER

2.1 FRONT OF THE METER

Figure 2-1 shows each part of the front of the meter.

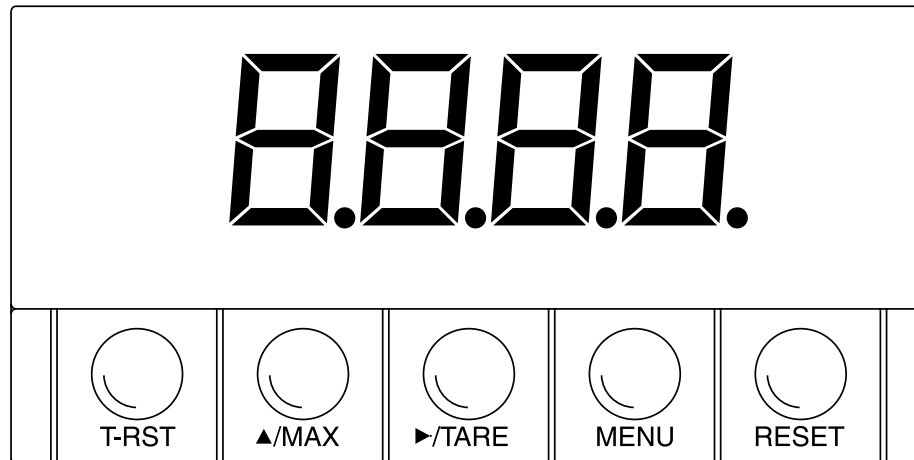

Figure 2-1. Front Panel

METER DISPLAY:

Digital LED display: -9999 or 9999 4-digit 7-segment, 0.56" high LED display with programmable decimal point.

METER MODES:

- | | |
|--------------------|--|
| Run Mode | The meter is in the run mode when the display is actively showing a process. |
| Configuration Mode | The meter is in the configuration mode when you press the MENU button to enable meter configurations. |

METER BUTTONS

T-RST button - Clears the tare value.

▲/MAX button - In the run mode, press the **▲/MAX** button to show the maximum value if jumper S3 is installed: the meter momentarily shows “**▯▯▯▯▯**”, then flashes the maximum value encountered since the last peak reset. Press the **▲/MAX** button to show the **VALLEY** value *if jumper S3 is removed*: the meter momentarily shows “**▯▯▯▯▯**”, then flashes the minimum value encountered since the last valley reset. In the configuration mode, press the **▲/MAX** button to change the flashing digit’s value (increments by one).

▲/TARE button - In the run mode, press the **▲/TARE** button to tare the display value to zero. In the configuration mode, press the **▲/TARE** button to scroll through available choices, or to move one digit to the right.

MENU button - In the run mode, press the **MENU** button to enable meter configuration changes. Refer to specific procedure for more details.

RESET button - In the run mode, press the **RESET** button to reset the Peak and Valley registers: the meter momentarily shows “**PrSt**” or “**VrSt**”, then resets both values. In the configuration mode, press the **RESET** button twice quickly to escape from the configuration mode.

2.2 BACK OF THE METER

Figure 2-2 shows the connectors on the back of the meter. Table 2-1 gives a brief description of each connector at the back of the meter. Refer to Figure 2-3 for dc-power connection information.

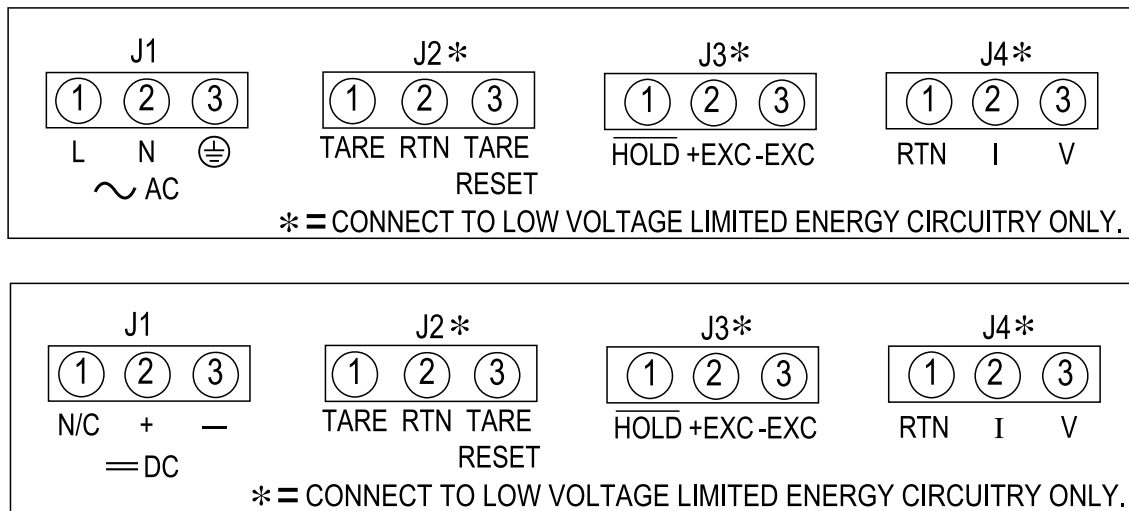

Figure 2-2. Connectors for ac-Power (Top) and dc-Power (Bottom)

Table 2-1. Connector Description

Connector	Description
J1-1	ac line connection (No Connection on dc-powered units).
J1-2	ac neutral connection (+ input on dc-powered units).
J1-3	ac earth ground (dc-power return on dc-powered units).
J2-1	Remote tare connection with momentary switch to J2-2.
J2-2	Digital Return (RTN).
J2-3	Tare reset with momentary switch to J2-2.
J3-1	Hold input (active low) - Connect to J2-2 to hold meter reading (does not update Min/Max).
J3-2	+EXC: Positive excitation connection from meter (10, 24 Vdc).
J3-3	-EXC: Negative excitation connection from meter (10, 24 Vdc).
J4-1	Analog Input return (RTN).
J4-2	Analog Current input (4-20 mA).
J4-3	Analog Voltage input (0-5 V, 0-10 V etc.).

2.2 BACK OF THE METER (Continued)

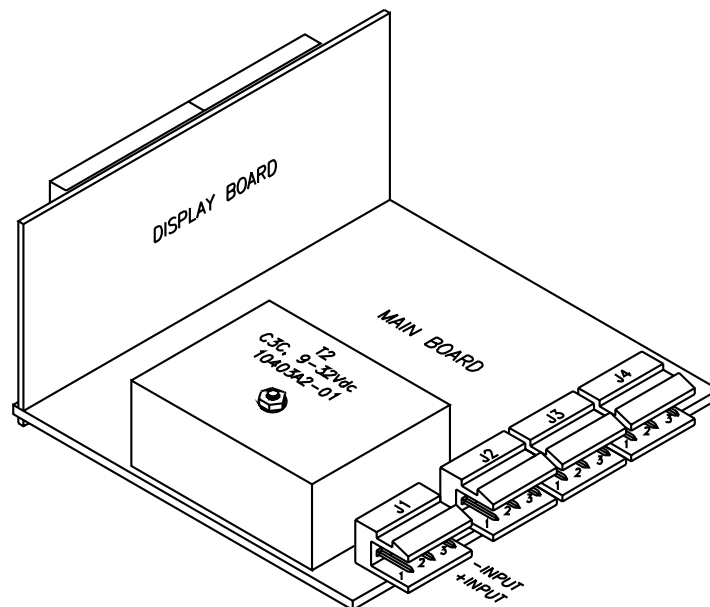

Figure 2-3. dc-Power Connections

2.3 DISASSEMBLY

You may need to open up the meter for one of the following reasons:

- * To check or change the 115 or 230 Vac power jumpers.
- * To install or remove calibration jumper on the main board.

Note

Disconnect the power supply before proceedings.

To remove and access the main board, follow these steps:

1. Disconnect the main power from the meter.
2. Remove the front lens.
3. Pull the meter forward, out of its case.

SECTION 3. GETTING STARTED



CAUTION: The meter has no power-on switch, so it will be in operation as soon you apply power.

If you power off/on the meter momentarily shows the following: “**idP**” for model type, “**codE**” , and “**rxX**” for the micro controller revision code.



Keep track of revision code for future reference.

3.1 CHANGING CONFIGURATION JUMPERS

The S1, S2 and S3 DIP switches are at the front of the meter near the digital display. The S4 DIP switch is on side of the main board (refer to Figure 3–3). Remove the lens cover to access these jumpers.

Table 3-1. S1 - S4 DIP Switches (Defaults in bold and italics)

Jumper	Description
S1	Installed: 10 volt excitation <i>Removed: 24 volt excitation</i>
S2	Installed: Front-panel buttons locked out <i>Removed: All buttons operable</i>
S3	<i>Installed: PEAK shows when ▲/MAX button is pushed</i> Removed: VALLEY shows when ▲/MAX button is pushed
S4	Installed: Calibration enabled <i>Removed: Calibration disabled</i>

3.1 CHANGING CONFIGURATION JUMPERS (Continued)

Front of the meter

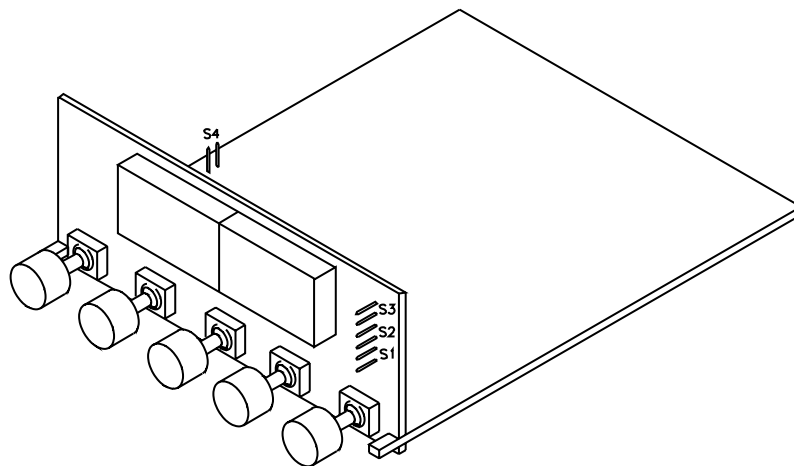

Figure 3-1. S1 - S4 Jumpers

3.2 MOUNTING THE METER

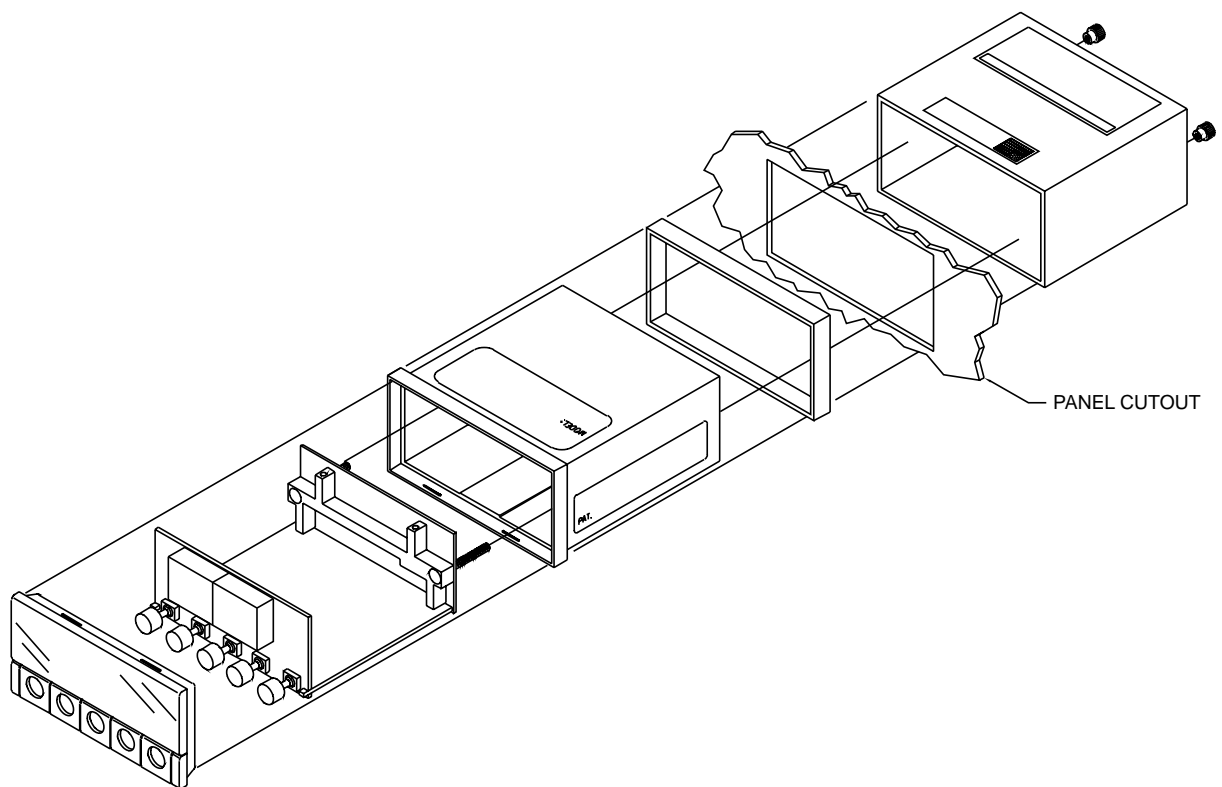

Figure 3-2. Meter - Exploded View

3.2 MOUNTING THE METER (Continued)

1. Cut a hole in your panel according to the dimensions specified in Figure 3-3.
2. Insert the meter into the hole. Be sure the front bezel is flush to the panel.

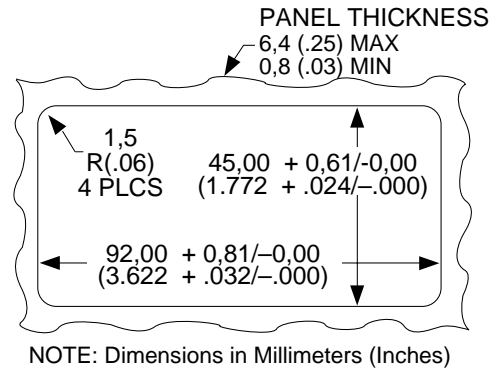

Figure 3-3. Panel Cut-Out

3. Proceed to Section 3.4 to connect your sensor input.

3.3 CONNECTING SENSOR INPUT

Figures 3-4 through 3-8 describe how to connect common sensor types.

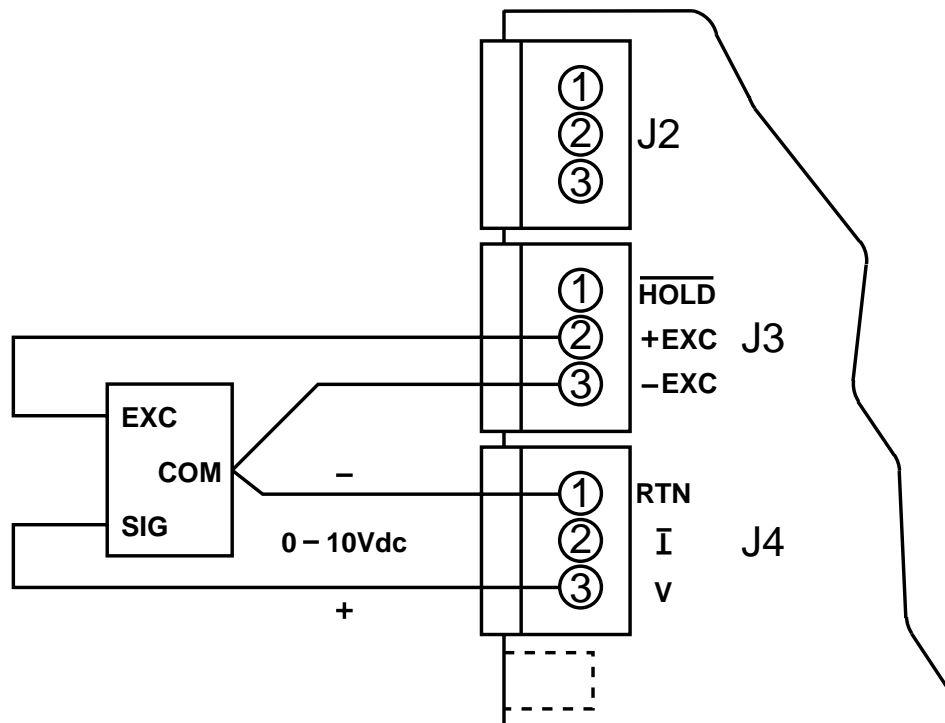

Figure 3-4. 3-Wire dc Voltage Input Connection with Internal Excitation

3.3 CONNECTING SENSOR INPUT (Continued)

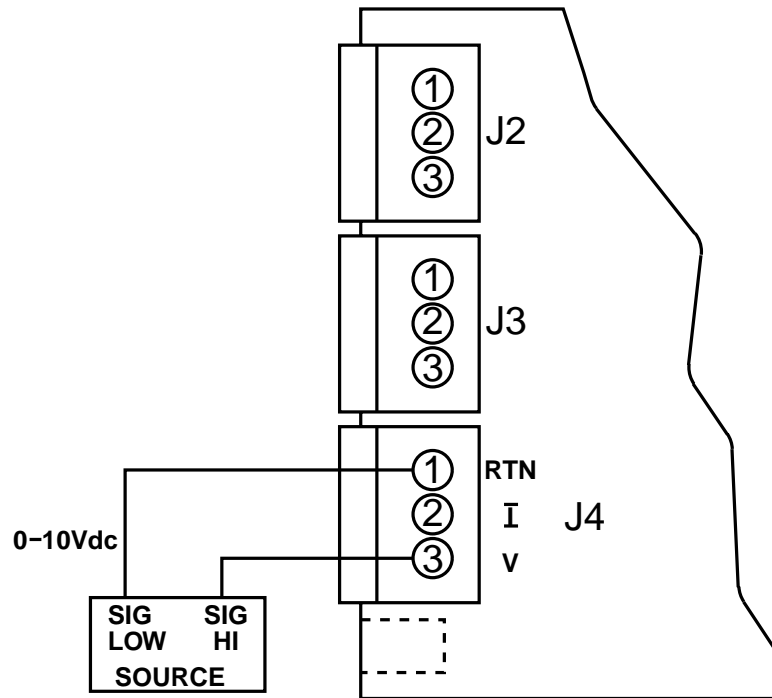

Figure 3-5. 2-Wire dc Voltage Input Connections with External Excitation

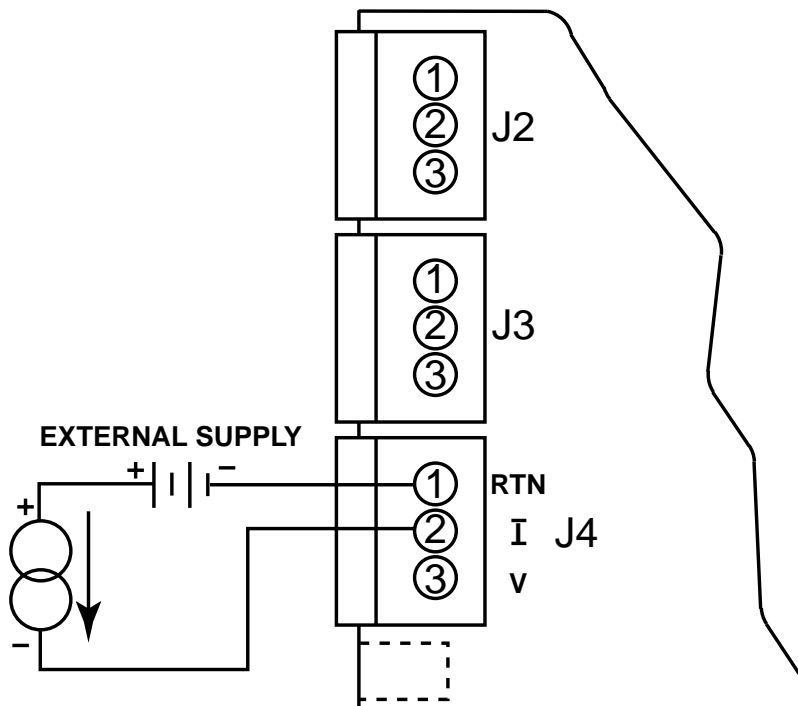

Figure 3-6. 4-20 mA Input Connections with External Excitation

3.3 CONNECTING SENSOR INPUT (Continued)

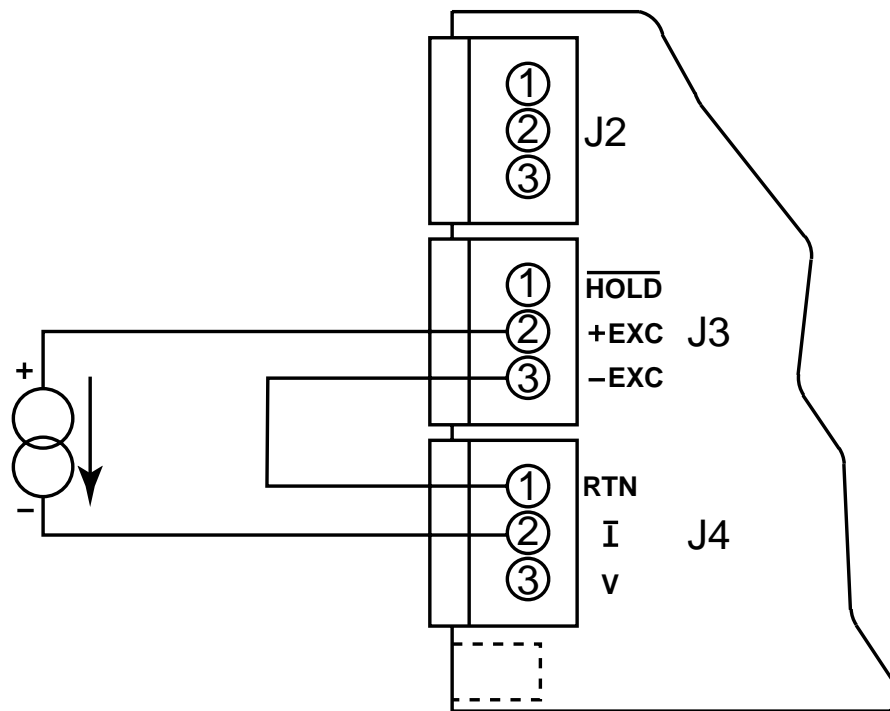

Figure 3-7. 4-20 mA Transmitter Hook-Up with Internal Excitation

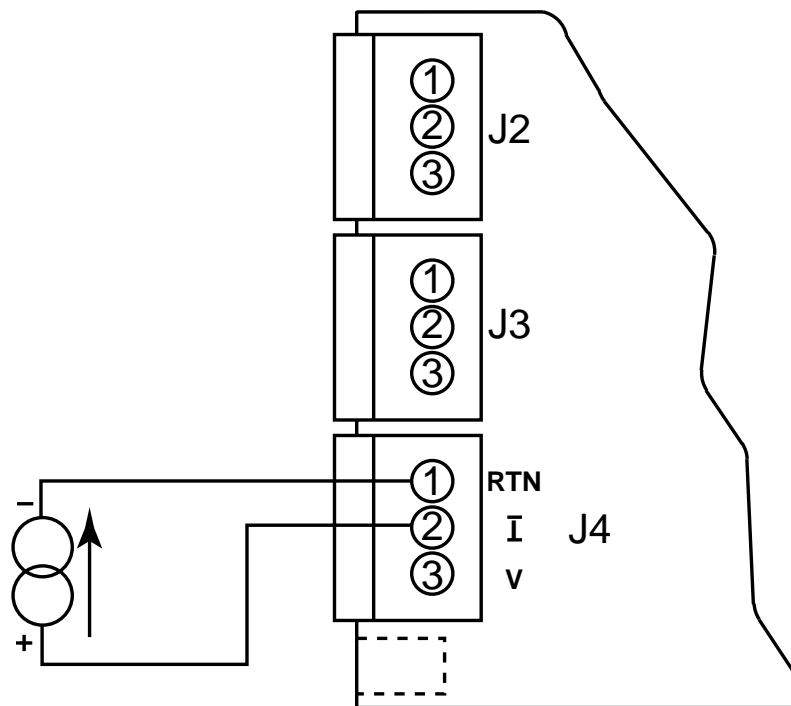

Figure 3-8. dc Current Input Connections with Current Source

3.4 CONNECTING MAIN POWER

Connect the ac main power connections as shown in Figure 3-9.



WARNING: Do not connect ac power to your meter until you have completed all input and output connections. Failure to do so may result in injury!

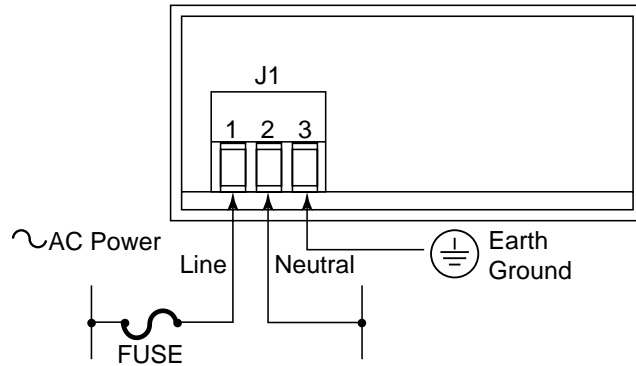

Figure 3-9. Main Power Connections - ac

Table 3-2 shows the wire color and respective terminal connections for both USA and Europe.

Table 3-2. ac-Power Connections

J1	AC POWER	WIRE COLORS	
		EUROPE	USA
1	~ ac Line	Brown	Black
2	~ ac Neutral	Blue	White
3	~ ac Earth Ground	Green/Yellow	Green

Connect the dc main power connections as shown in Figure 3-10.

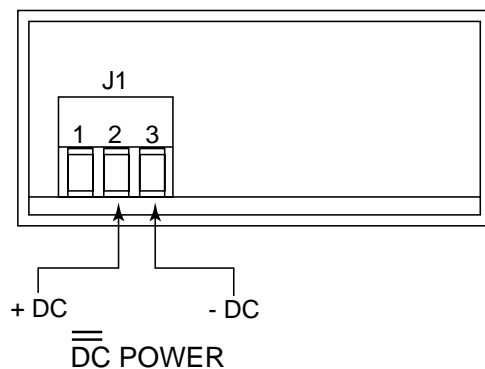

Figure 3-10. Main Power Connections - DC

SECTION 4. CONFIGURING THE METER

4.1 SELECTING THE INPUT RANGE (INPT)



Refer to Table B-2 for a summary list of menu configuration.

To select your appropriate input range, follow these steps:

1. Press the **MENU** button. The meter flashes **“InP”**.
2. Press the **▶/TARE** button. The meter flashes one of the following:
 - * 0 - 10 (for 0-10 volt)
 - * 4 - 20 (for 4-20 mA)
 - * 20 - 4 (for 20-4 mA)
 - * 0 - 5 (for 0-5 volt)
 - * 1 - 5 (for 1-5 volt)
3. Press the **▶/TARE** button to scroll through available choices.
4. Press the **MENU** button to store your choice. The meter momentarily shows **“StOr”**, followed by **“dEc.P”** (Decimal point).

4.2 SELECTING A DECIMAL POINT POSITION (DEC.P)



Refer to Table B-2 for a summary list of menu configuration.

To select a decimal point display position, follow these steps:

1. Press the **MENU** button until the meter shows “**dEc.P**”.
2. Press the **▶/TARE** button. The meter shows one of the following:

- * FFF.F
- * FFFF.
- * FFFF
- * F.FFF
- * FF.FF

3. Press the **▶/TARE** button to move the decimal point to the right one position.
4. Press the **MENU** button to store your choice. The meter momentarily shows “**Stor**”, followed by “**ScAL**” (Scaling).

4.3 SCALING THE METER

There are two scaling methods. One method is internal scaling, “**int**” (scaling without known loads): you decide upon low and high reading values and manually enter them through the keyboard. The meter then operates with those new parameters. Another method is live scaling, “**Live**” : you apply low and high input signals and change the meter reading accordingly. The meter calculates a new scale factor and then operates with those new parameters.

4.3.1 Internal Scaling

Use internal scaling if you do not have an actual input signal to the meter. With internal scaling the input values are assumed to be the low and high signal input based on the selection input (e.g. if you selected 4-20 mA input, the “rd1” input value will be 0400 for 4 mA and “rd2” will be 2000 for 20 mA). All you need to do is change what the meter should read at these two points. For internal scaling, follow these steps:

Note

Refer to Table B-2 for a summary list of menu configuration.

1. Press the **MENU** button until the meter flashes “**ScAL**”.
2. Press the **▶/TARE** button until the meter shows “**int**”.
3. Press the **▲/MAX** button. The meter momentarily flashes “**rd1**” (read 1), then shows the low input value based on the selected input range (e.g. if the input range is 0 - 10 V, the meter shows “**0000**”, or if input range is 4-20 mA, the meter shows “**0400**”).
4. Enter the desired reading for this low input value using the **▲/MAX** and **▶/TARE** buttons.
5. Press the **MENU** button for the meter to accept the new value. The meter then momentarily flashes “**rd2**”, then shows the high input value based on the selected input range (e.g. if the input range is 0 - 10 V, the meter shows “**9999**” or if the input range is 4-20 mA, the meter shows “**2000**”).
6. Enter the desired reading for this high input value using the **▲/MAX** and **▶/TARE** buttons.
7. Press the **MENU** button for the meter to accept the new value, save changes and return to the run mode. The meter shows “**Stor**” and calculates the new scale factor based on the new high and low values.
8. If the display is not zero with no load on your sensor, press the **▶/TARE** button. Scaling is now complete.

4.3.2 Live Scaling

Use live scaling when a stable input source is available (e.g. 4-20 mA or voltage calibrator). Also use live scaling when the actual input from your sensor can be set to output values close to the low and high ends of your input. For live scaling, follow these steps:

Note

Refer to Table B-2 for a summary list of menu configuration.

1. Press the **MENU** button until the meter flashes “**ScAL**” .
2. Press the **▶/TARE** button until the meter shows “**Live**”.
3. Press the **▲/MAX** button. The meter momentarily flashes “**rd1**” .
4. Apply the low input signal to the input. The meter then shows the live low input source.
5. Change the meter reading as required for the applied low input using the **▲/MAX** and **▶/TARE** buttons.
6. Press the **MENU** button for the meter to accept the new value. The meter then momentarily flashes “**rd2**” .
7. Apply the high input signal to the input. The meter then shows the live high input source.
8. Change the meter reading as required for the applied high input using the **▲/MAX** and **▶/TARE** buttons.
9. Press the **MENU** button to save changes and return to the run mode. The meter shows “**Stor**” and calculates the new scale factor based on the new high and low values.

4.4 CHANGING THE METER S CALIBRATION



CAUTION: It is not necessary to calibrate a brand new meter, it arrives completely calibrated. The following procedure modifies the calibration of the meter.

This procedure should only be performed by qualified personnel with accurate test equipment.

To change the meter's calibration, follow these steps:

Note

Disconnect the main power from the meter.

1. Install jumper S4 to enable the calibration procedure (refer to Figure 3-3).
2. Slide the main board back into the case and replace the cover.
3. Power on the meter.
4. Select the input range you want to calibrate (refer to Section 4.1, Selecting Input Range)
5. Press the **MENU** button until the meter flashes "LINE". The meter will indicate the line frequency it is currently using. Line frequency default is 60H for 60 Hz and 50H for 50 Hz.
6. Press the **▶/TARE** button until the correct line frequency shows.
7. Press the **MENU** button to store this line frequency selection. Once you store your selection, the meter flashes "**cAL**".
8. Press the **▶/TARE** button to initiate the calibration procedure. The meter momentarily flashes the selected input range that you are about to calibrate, then flashes "**rd1**".
9. Apply 0 Vdc or 0 mA and change the display to "**0000**". Use the **▶/TARE** and **▲/MAX** buttons to change the digits.

4.4 CHANGING THE METER S CALIBRATION (Continued)

10. Press the **MENU** button for the meter to accept the new value. The meter then flashes “**rd2**” .
11. Apply the high input voltage or current for the selected input range (e.g. apply 9.900 V if you are calibrating 0-10 V range).

 *To calibrate the entire meter, you only need to calibrate the following three ranges: 0-10 V, 0-5 V and 4-20 mA.*

Table 4-1. Meter Calibration Table

Range	Low Input	rd1*	Input High	rd2*
0-10V	0 Vdc	0000	9.9 Vdc	9900
0-5, 1-5V	0 Vdc	0000	5.0 Vdc	5000
4-20, 20-4 mA	0 mA	0000	20.0 mA	2000

* Disregard decimal point

12. Change the display to equal the input source (e.g. if you apply 9.900 V for the high input voltage, change the meter reading to “9900”). Press the **▲/MAX** button to change the flashing digit’s value (increments by one) and press the **▶/TARE** button to move from one digit to the next.
13. Press the **MENU** button once more to save changes. The meter shows “**Stor**” and is now calibrated for the selected range.
14. Power off the meter. Remove the S4 jumper (to ensure no accidental changes). Slide main board back into the case.
15. Power on the meter.

APPENDIX A

CHECKING AND CHANGING MAIN BOARD POWER JUMPERS



IMPORTANT: If you want to change the Factory preset jumpers, do the following steps:



Disconnect the power from the unit before proceeding.

1. Remove the main board from the case. Refer to Section 2.6.
2. Locate the jumpers W1, W2, W3 and W4 (located near the edge of the main board alongside the transformer).
3. If your power requirement is 115 Vac, install jumpers W1 and W2. If your power requirement is 230 Vac, install jumpers W4 and W3. Refer to Figures A-1 and A-2.



Refer to Section 2.5, *Back of the Meter*, for more information on dc-power connections.

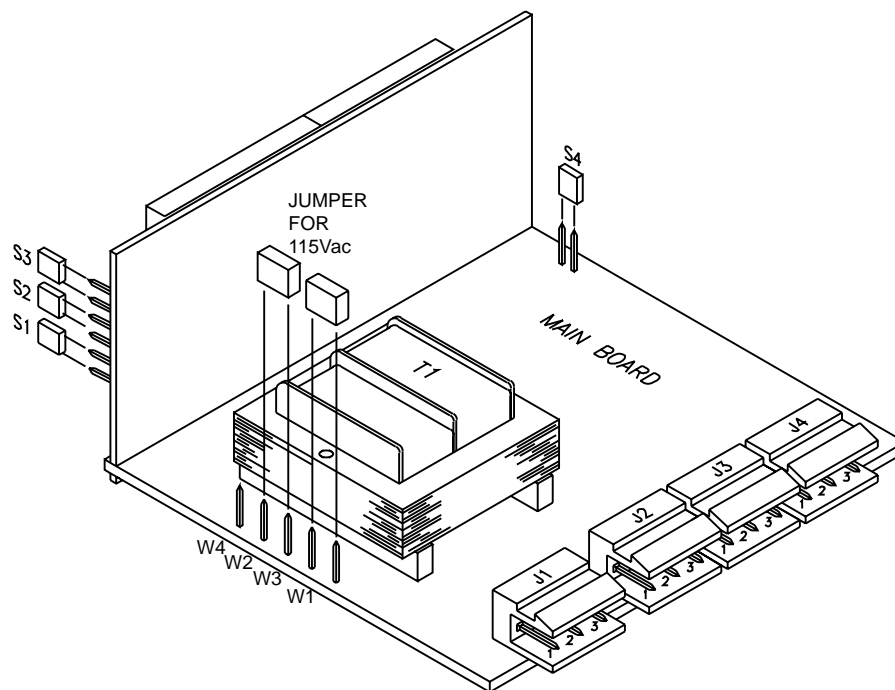

Figure A-1. 115Vac Jumper Wiring (Default)

APPENDIX A - CHECKING AND CHANGING MAIN BOARD POWER JUMPERS (Continued)

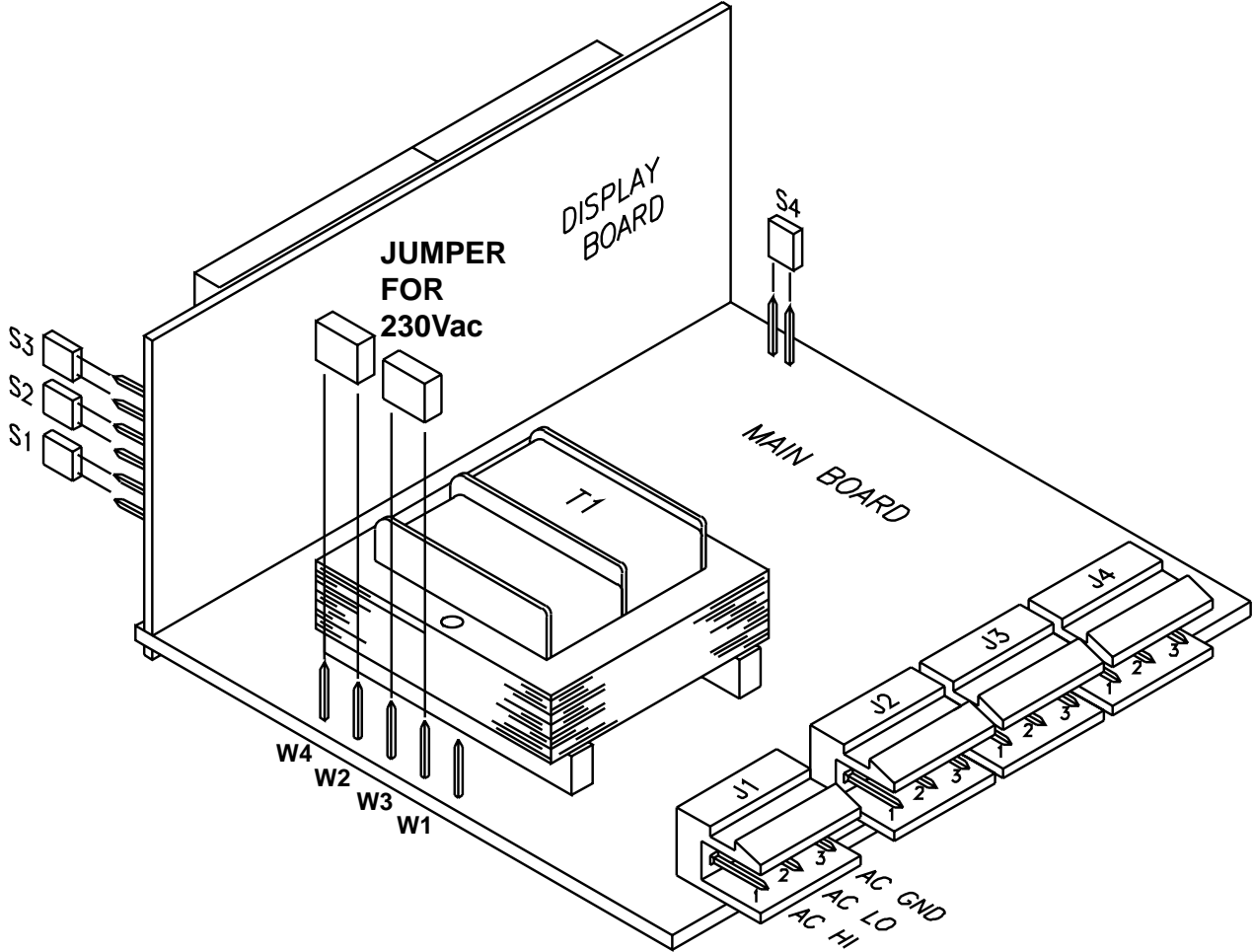

Figure A-2. 230 Vac Jumper Wiring

APPENDIX B

REFERENCE TABLES

Table B-1. Display Messages

MESSAGE	DESCRIPTION
<i>nnnn</i>	Peak value to follow
<i>uuuu</i>	Valley value to follow
<i>n 123*</i>	Peak value reached overload
<i>u 123*</i>	Valley value reached overload
ER 1	Scaling format error
PrSt	Peak reset
VrST	Valley reset
T-RST	Tare reset. Clears tare value.

* Represents any value

Table B-2. Menu Configuration Displays

MENU	▶/TARE	▲/MAX
InP	0-10	
	4-20	
	20-4	
	0-5	
	1-5	
DEC.P	FFF.F	
	FFFF.	
	FFFF	
	F.FFF	
	FF.FF	
ScAL	int	
	Live	rd 1*
		XXXX
		rd 2*
		XXXX

* Not displayed unless you press the ▲/MAX key.

APPENDIX B - REFERENCE TABLES (Continued)

Table B-3. Run Mode Displays

Display	►/TARE	▲/MAX	RESET	T-RST	Jumpers
PrST Peak Reset			Press to activate		S3 installed
VrST Valley Reset			Press to activate		S3 removed
nnnn Peak Value to follow		Press to activate*			S3 installed
uuuu Valley value to follow		Press to activate*			S3 removed
T-RST Clears tare value				Press to activate	
Tare Display	Press to activate				

* Press ►/MAX again to remove peak or valley reading and display process value.

Table B-4. Factory Preset Values

Menu Item	Description
INPT	Input Range: 4-20 mA = 0 - 100.0
DEC.P	Decimal Point Position: FFF.F
Sensor Excitation: 24 Vdc	
Line Frequency: 60 Hz	

APPENDIX C

SPECIFICATIONS

Analog Input Ranges:	4-20 mA, 0-5 Vdc, 1-5 Vdc, 0-10 Vdc
Input Impedance:	Voltage: 1.0 Meg Current: 100
Isolation:	Dielectric strength to 2500V transient per 3mm spacing base on EN61010 for 260Vrms or dc working voltage
Accuracy:	0.05%R +/- LSB
Tempco:	+/- 50 PPM/°C
Excitation Voltage:	24 Vdc @ 25mA 10 Vdc @ 25mA
Display:	LED 7-segment, 14.2 mm (0.56") Range: +9999 to -1999 Decimal Point: 4 positions
Input Power Information:	
Voltage	ac: 115/230 Vrms ±10% dc: 9-32Vdc (Isolated up to 300 Vp)
Power:	1.5 watt Excitation Unloaded 2.5 Watts Maximum (with 20mA excitation load)
Frequency:	50/60 Hz
External Fuse Protection Recommended:	
	ac 115V UL slow blow, 40mA, 250V
	ac 230V UL slow blow, 20mA, 250V
Environment:	
Operating Temperature:	0° to 60°C (32° to 140° F)
Storage Temperature:	-40° to 85°C (-40° to 185° F)
Relative Humidity:	95% at 40°C (non-condensing)
Mechanical	
Panel Cutout:	DIN 4896-100 / 1.77 x 3.66" (45 x 92 mm)
Depth Behind Bezel:	3.94 in (100 mm)
Weight:	11 oz (312 g)
Case Material:	Polycarbonate, 94 V-O UL rated
External Features:	Tare, Display Hold, Tare Reset

APPENDIX C - SPECIFICATIONS (Continued)

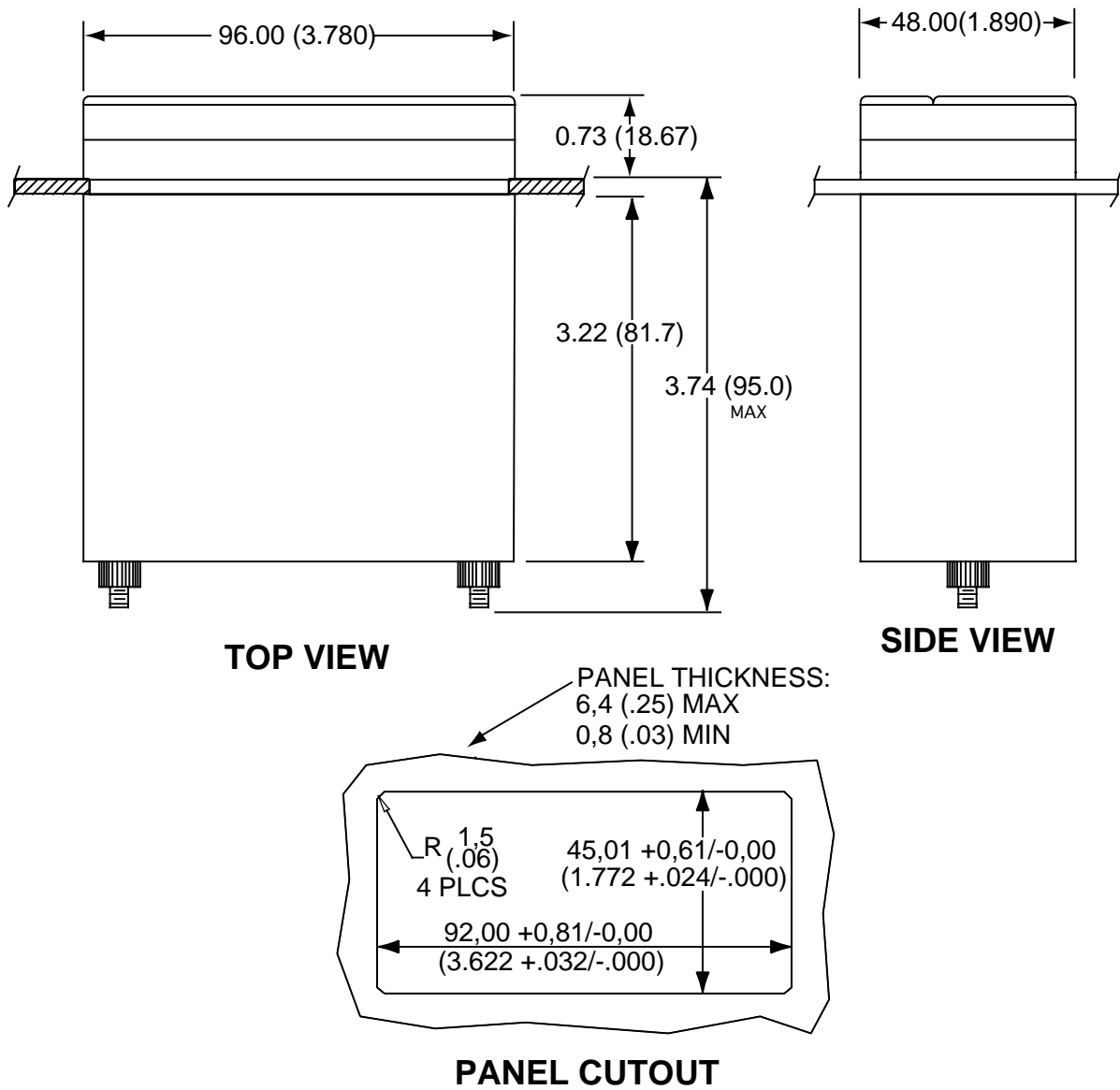

Figure C-1. Meter Dimensions



APPENDIX D - CE INFORMATION

This product conforms to the EMC directive 89/336/EEC amended by 93/68/EEC, and with the European Low Voltage Directive 72/23/EEC.

Electrical Safety EN61010-1:2001

Safety requirements for electrical equipment for measurement, control and laboratory.

- Double Insulation: Primary to Secondaries
- Pollution Degree 2
- Measurement *Category I

Note 1: *Measurements performed on circuits not directly connected to the Mains Supply (power). Maximum Line-to-Neutral working voltage 50Vac/dc.

Note 2: This unit should not be used in Measurement Categories II, III, IV.

- Dielectric withstand Test per 1 min (50/60Hz)
Power to Input/Output 2500Vac
- Transients Overvoltage
Input Power Transients Overvoltage 2500V
Input/Output Signals Transients Overvoltage 500V

EMC EN61326:1997 + and A1: 1998 + A2: 2001

Immunity and Emissions requirements for electrical equipment for measurement, control and laboratory.

- EMC Emissions Class B, EN61326
- EMC Immunity** Table 1, EN61326

** I/O Signal and Control Lines require shielded cables and these cables must be located on conductive cable trays or in conduits. Furthermore, the length of these cables should not exceed 30 meters.



Refer to the EMC and Safety installation considerations (Guidelines) of this manual for additional information.

INDEX

- Calibration
 - and the S4 jumper 7
 - changing 17, 18
 - installing/removing calibration jumper 6
- Configuration jumpers
 - changing 7, 8
- Configuration mode 3
 - escaping from 4
 - RESET button 4
 - ▲/MAX button 4
 - ▶/TARE button 4
- Connecting sensor input 9-11
- Connector label 5
- dc-power 6
 - 2-wire voltage input connections 10
 - 3-wire voltage input connection 9
 - connectors 5, 6
 - current input connections 11
- Decimal point
 - disregarding in meter calibration 18
 - factory default 20
 - selecting 14
- Disassembly 6
- Front-panel buttons
 - MENU 4
 - RESET 4
 - T-RST 4
 - ▲/MAX 4
 - ▶/TARE 4
- Input range
 - and internal scaling 15
 - calibrating 17
 - factory default 20
 - selecting 13
- Installing the meter 9
- Internal scaling 15

INDEX

- Live scaling 16
- Main board power jumpers 23, 24
- MENU button 4
- Meter modes
 - configuration mode 3
 - run mode 3
- micro controller revision code
 - accessing 7
- Mounting the meter 9
- RESET button 4
- Resetting peak and valley registers 4, 20
- Run mode 3
 - MENU button 4
 - RESET button 4
 - ▲/MAX button 4
 - ▶/TARE button 4
- S1, S2 & S3 DIP switches
 - changing 7
- Scaling
 - error message 19
 - internal 14, 15
 - live 14, 16
- Scaling without known loads 14, 15
- Sensor excitation
 - factory default 20
- Sensor input 9-11
 - connecting 9-11
- T-RST button 4
- Voltage calibrator
 - and live scaling 16
- ▲/MAX button 4
- ▶/TARE button 4

Warranty/Disclaimer

NEWPORT Electronics, Inc. warrants this unit to be free of defects in materials and workmanship for a period of one (1) year from the date of purchase. In addition to NEWPORT's standard warranty period, NEWPORT Electronics will extend the warranty period for **four (4) additional years** if the warranty card enclosed with each instrument is returned to NEWPORT.

If the unit should malfunction, it must be returned to the factory for evaluation. NEWPORT's Customer Service Department will issue an Authorized Return (AR) number immediately upon phone or written request. Upon examination by NEWPORT, if the unit is found to be defective it will be repaired or replaced at no charge. NEWPORT's WARRANTY does not apply to defects resulting from any action of the purchaser, including but not limited to mishandling, improper interfacing, operation outside of design limits, improper repair, or unauthorized modification. This WARRANTY is VOID if the unit shows evidence of having been tampered with or shows evidence of being damaged as a result of excessive corrosion; or current, heat, moisture or vibration; improper specification; misapplication; misuse or other operating conditions outside of NEWPORT's control. Components which wear are not warranted, including but not limited to contact points, fuses, and triacs.

NEWPORT is pleased to offer suggestions on the use of its various products. However, NEWPORT neither assumes responsibility for any omissions or errors nor assumes liability for any damages that result from the use of its products in accordance with information provided by NEWPORT, either verbal or written. NEWPORT warrants only that the parts manufactured by it will be as specified and free of defects. NEWPORT MAKES NO OTHER WARRANTIES OR REPRESENTATIONS OF ANY KIND WHATSOEVER, EXPRESSED OR IMPLIED, EXCEPT THAT OF TITLE, AND ALL IMPLIED WARRANTIES INCLUDING ANY WARRANTY OF MERCHANTABILITY AND FITNESS FOR A PARTICULAR PURPOSE ARE HEREBY DISCLAIMED. LIMITATION OF LIABILITY: The remedies of purchaser set forth herein are exclusive and the total liability of NEWPORT with respect to this order, whether based on contract, warranty, negligence, indemnification, strict liability or otherwise, shall not exceed the purchase price of the component upon which liability is based. In no event shall NEWPORT be liable for consequential, incidental or special damages.

CONDITIONS: Equipment sold by NEWPORT is not intended to be used, nor shall it be used: (1) as a "Basic Component" under 10 CFR 21 (NRC), used in or with any nuclear installation or activity; or (2) in medical applications or used on humans. Should any Product(s) be used in or with any nuclear installation or activity, medical application, or used on humans, or misused in any way, NEWPORT assumes no responsibility as set forth in our basic WARRANTY / DISCLAIMER language, and additionally purchaser will indemnify NEWPORT and hold NEWPORT harmless from any liability or damage whatsoever arising out of the use of the Product(s) in such a manner.

Return Requests/Inquiries

Direct all warranty and repair requests/inquiries to the NEWPORT Customer Service Department. **BEFORE RETURNING ANY PRODUCT(S) TO NEWPORT, PURCHASER MUST OBTAIN AN AUTHORIZED RETURN (AR) NUMBER FROM NEWPORT'S CUSTOMER SERVICE DEPARTMENT (IN ORDER TO AVOID PROCESSING DELAYS).** The assigned AR number should then be marked on the outside of the return package and on any correspondence.

The purchaser is responsible for shipping charges, freight, insurance and proper packaging to prevent breakage in transit.

FOR **WARRANTY** RETURNS, please have the following information available BEFORE contacting NEWPORT:

1. P.O. number under which the product was PURCHASED,
2. Model and serial number of the product under warranty, and
3. Repair instructions and/or specific problems relative to the product.

FOR **NON-WARRANTY** REPAIRS, consult NEWPORT for current repair charges. Have the following information available BEFORE contacting NEWPORT:

1. P.O. number to cover the COST of the repair,
2. Model and serial number of product, and
3. Repair instructions and/or specific problems relative to the product.

NEWPORT's policy is to make running changes, not model changes, whenever an improvement is possible. This affords our customers the latest in technology and engineering.

NEWPORT is a registered trademark of NEWPORT Electronics, Inc.

© Copyright 2007 NEWPORT Electronics, Inc. All rights reserved. This document may not be copied, photocopied, reproduced, translated, or reduced to any electronic medium or machine-readable form, in whole or in part, without prior written consent of NEWPORT Electronics, Inc.

For immediate technical or application assistance please call:

1-800-6397678®
1-800-NEWPORT

Newport Electronics, Inc.
2229 South Yale Street • Santa Ana, CA • 92704 • U.S.A.
TEL: (714) 540-4914 • FAX: (203) 968-7311
Toll Free: 1-800-639-7678 • www.newportUS.com • e-mail: info@newportUS.com
ISO 9001 Certified

Newport Technologies, Inc.
976 Bergar • Laval (Quebec) • H7L 5A1 • Canada
TEL: (514) 335-3183 • FAX: (514) 856-6886
Toll Free: 1-800-639-7678 • www.newport.ca • e-mail: info@newport.ca

Newport Electronics, Ltd.
One Omega Drive • River Bend Technology Centre
Northbank, Irlam • Manchester M44 5BD • United Kingdom
Tel: +44 161 777 6611 • FAX: +44 161 777 6622
Toll Free: 0800 488 488 • www.newportuk.co.uk • e-mail: sales@newportuk.co.uk

Newport Electronics B.V. - Benelux
TEL: +31 20 3472121 • FAX: +31 20 6434643
Toll Free: 0800 0993344 • www.newport.nl • e-mail: info@newport.nl

Newport Electronics spol s.r.o.
Frystatska 184, 733 01 Karviná • Czech Republic
TEL: +420 59 6311899 • FAX: +420 59 6311114
Toll Free: 0800-1-66342 • www.newport.cz • e-mail: info@newport.cz

Newport Electronics GmbH
Daimlerstrasse 26 • D-75392 Deckenpfronn • Germany
TEL: 49 7056 9398-0 • FAX: 49 7056 9398-29
Toll Free: 0800 / 6397678 • www.newport.de • e-mail: sales@newport.de

Newport Electronique S.A.R.L. - France
TEL: +33 1 61 37 29 00 • FAX: +33 1 30 57 54 27
Toll Free: 0800 466 342 • www.newport.fr • e-mail: sales@newport.fr

Mexico and Latin America
FAX: 001 (203) 359-7807
TEL En Español: 001 (203) 359-7803

NEWPORTnetSM On-Line Service www.newportUS.com
--

Internet e-mail info@newportUS.com
--

 **NEWPORT** Electronics, Inc.

M1866/0307

12160ML-01 Rev. K