

DDM 4

4 Digit LCD Data Display Module

The DDM 4 is a low power 4 digit data display module which usually operates under microprocessor control. Inputs are CMOS and TTL compatible. Using three inputs; Clock, Data In and Load, it is possible to individually address each LCD segment, permitting 0 to 9 and A to F to be displayed plus any other combination of the segments. Hand-held cases for the DDM 4 are available (Veronex hand-held size 3 and OKW Type M and P enclosures).

- 🔊 12.7mm (0.5") Digit Height
- 🔊 Requires Only Three Control Lines
- 🔊 Can be Cascaded
- 🔊 CMOS and TTL Compatible
- 🔊 Easily Interfaced To Microprocessors
- 🔊 5V LED Backlighting
- 🔊 Low Power



TIMING DIAGRAM

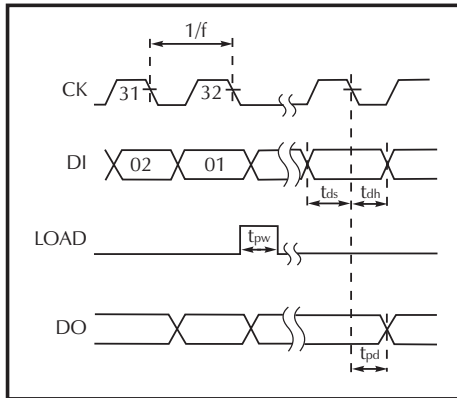

Stock Number
Standard Meter

DDM 4

DC CHARACTERISTICS

Specification	Symbol	Min.	Typ.	Max.	Unit
Supply voltage	V _{DD}	+3.0	5	+8.5	V
Supply current	I _{DD}		40	60	μA
Operating temp. range		0		50	°C
Input High level	V _{IH}	0.5V _{DD}		V _{DD}	V
Input Low level	V _{IL}	0		0.1V _{DD}	V
Input leakage current	I _L		0.01	±10	μA
Input capacitance	C _i			5.0	pF
Backlight voltage	V _{LMP}		5	5.5	V
Backlight current	I _{LMP}		50	75	mA

AC CHARACTERISTICS

Characteristics	Symbol	Min.	Max.	Units	Conditions
Clock rate	f	0	1.5	MHz	50% duty cycle
Data set-up time	t _{ds}	150		nS	Data change to CK falling edge
Data hold time	t _{dh}	50		nS	
Load pulse width	t _{pw}	175		nS	
Data out prop. delay	t _{pd}		500	nS	CL=55pF

DIMENSIONS All dimensions in mm (inches)

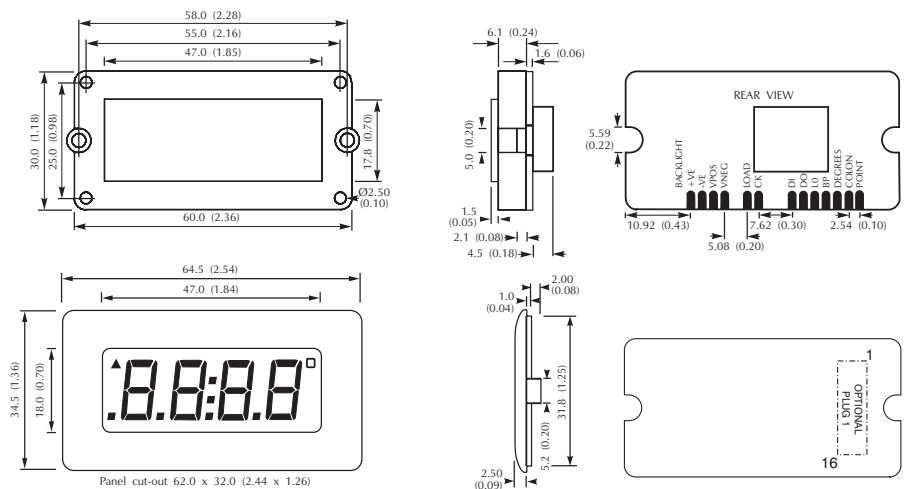

PANEL FITTING

Fit the bezel to the front of the panel and then locate the meter to the bezel from behind the panel. Using the four screws provided, secure the two plastic clips to the rear of the meter.

OPTIONAL PLUG 1 ON UNDERSIDE OF PCB

PIN FUNCTIONS

- (15) -VE } 5 Volt LED backlighting supply terminals.
- (16) +VE }
- (2) VPOS Positive supply voltage (VDD).
- (1) VNEG Negative supply voltage (VSS).
- (3) LOAD Load input: Causes a parallel load of the data from the shift register to the display latches at logic '1'.
- (4) CK Clockinput: The shift register loads, shifts and outputs (DO) on the falling edge.
- (5) DI Data input: A logic '1' on DI causes a segment to be visible.
- (6) DO Data output: To be used for cascading modules.
 For cascading: Connect DO to DI of next module. Each module will produce its own display drive. If an external driving signal is used, connect it to each module's L0 input.
Note: Do not connect backplane outputs together.
- (7) L0 LCD driving signal input. Leave open circuit or use for synchronising cascaded modules (see Application diagram *).
- (8) BP Backplane output.
- (9) DEGREES } Inputs for degree, colon and pointer. Note: If not used, tie these inputs to BP.
- (10) COLON }
- (11) POINT }

() Optional Plug 1 Pin Numbers

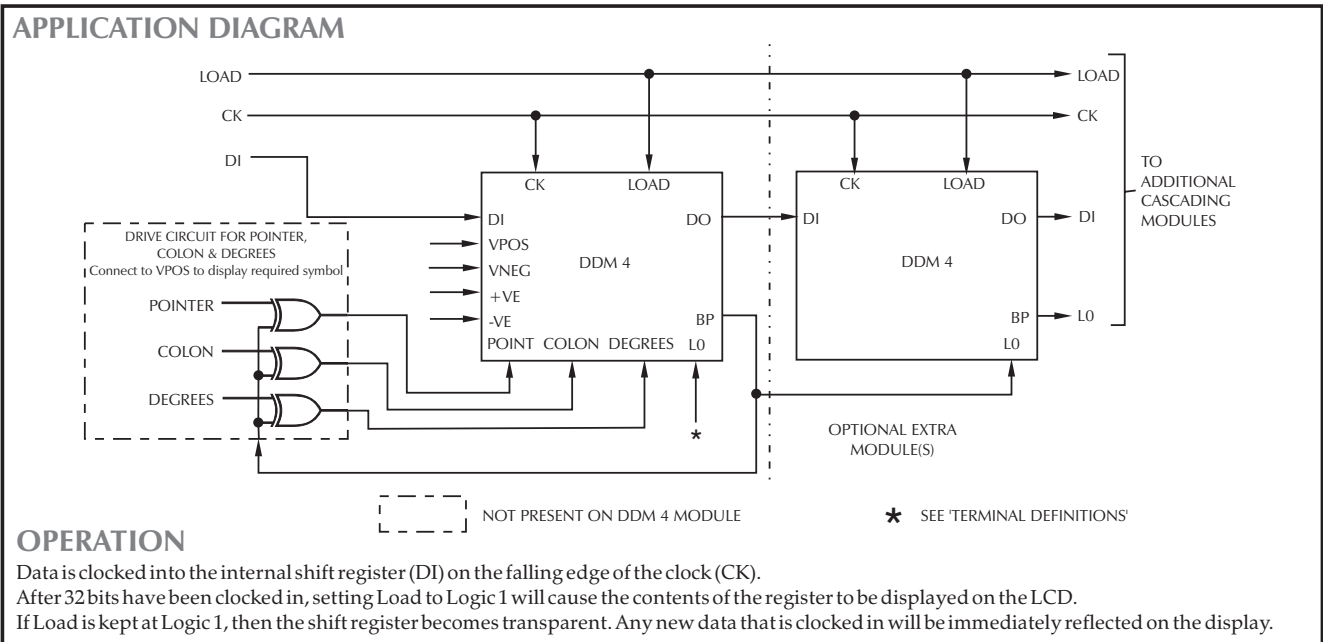

DISPLAY SHIFT REGISTER ASSIGNMENT

Note: A segment is visible when a logic '1' is present. For correct operation of the display, 32 bits of data must be clocked in. When clocking in 32 bits of display data the first input bit is the DP of digit 1 and the last bit is the G segment of digit 4.

DIGIT	CLOCK PULSE	SEGMENT	DIGIT	CLOCK PULSE	SEGMENT
DIGIT 4 'MSD' (LH digit)	1	G	DIGIT 2	17	G
	2	F		18	F
	3	A		19	A
	4	B		20	B
	5	C		21	C
	6	D		22	D
	7	E		23	E
	8	DP		24	DP
DIGIT 3	9	G	DIGIT 1 'LSD' (RH digit)	25	G
	10	F		26	F
	11	A		27	A
	12	B		28	B
	13	C		29	C
	14	D		30	D
	15	E		31	E
	16	DP		32	DP