

AB52

INTERVAL TIMERS

Industrial Timer Company

30 Industrial Park Road

Centerbrook, CT 06409

800-394-7130

www.industrialtimercompany.com

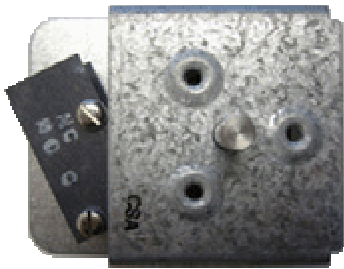

DESCRIPTION

The AB52 series of timers are basic interval timers requiring the interval to be reset manually at the beginning of each cycle. The timer features an external friction that provides low setting-torque and enables the setting to be changed during the cycle without damage. The load switch is an isolated single pole, double throw on the standard unit, however, the AB52 is available with a double pole, double throw on special order. Standard shaft rotation is clockwise when timing. Timing can also be started by rotating the shaft in either direction. Knobs and dials are available as separate items.

APPLICATION

The most basic interval timer is designed for applications requiring low cost and where since it is a function of the operator, accuracy of the cycle is not critical. Typical applications include Appliances, amusement devices, medical equipment, and battery chargers.

OPERATION

- 1) Turn the setting knob in either direction until it reaches the desired time interval.
- 2) When the setting knob is first turned, the load switch will transfer.
- 3) The timing motor will drive the unit in a clockwise direction to zero.
- 4) At zero, the load switch will transfer and the motor will shut down.

STANDARD MODELS

Model Number	Time Cycle
AB52-001	1 min.
AB52-002	10 min.
AB52-003	20 min.
AB52-004	30 min.
AB52-005	60 min.
AB52-006	2 hr.
AB52-007	6 hr.
AB52-008	8 hr.
AB52-009	12 hr.
AB52-010	24 hr.

SPECIFICATIONS

Repeat Accuracy	Depends on operator setting ability and resolution of dial
Load Switch Contacts	SPDT switch rated at 15amps, 125, 250VAC
Wiring	motor, 6-inch leads switch, ¼ " push-on terminals
Voltage	120V/60Hz standard. Consult factory for other voltages and frequencies.
Agency Approval	UL, CSA

AB52

INTERVAL TIMERS

Industrial Timer Company

30 Industrial Park Road

Centerbrook, CT 06409

800-394-7130

www.industrialtimercompany.com

DIMENSIONS

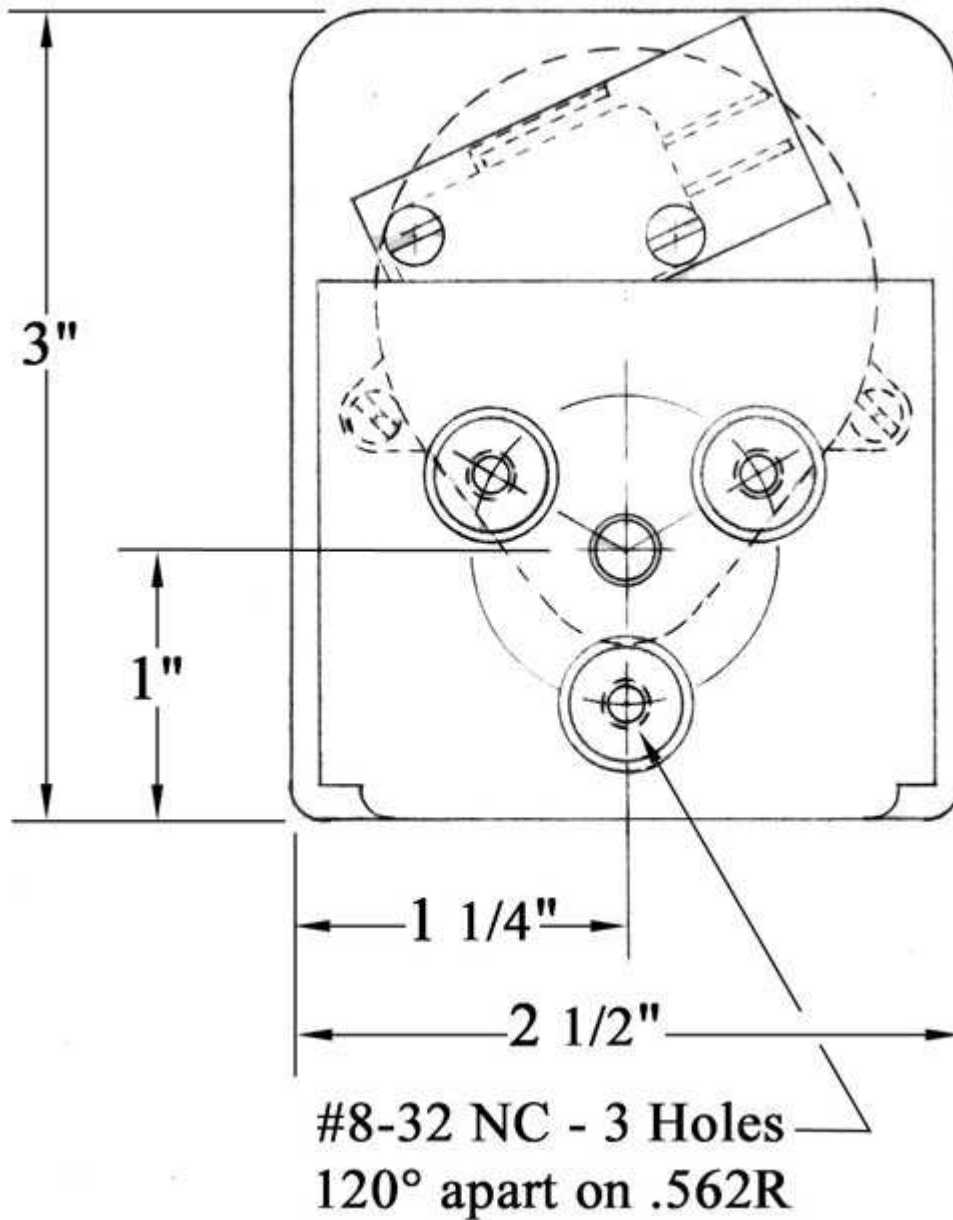

AB52

INTERVAL TIMERS

DIMENSIONS

Industrial Timer Company

30 Industrial Park Road

Centerbrook, CT 06409

800-394-7130

www.industrialtimercompany.com

