

## Permanent magnet stepper motors

## Commercial series

The M series instrument stepper motors are high quality permanent magnet types providing a choice of 18, 15, 7.5 or 3.6 degree step angle.

The motors may be specified fitted with gearheads where increased torque and resolution are required at reduced operating speed. The M series motors offer excellent performance combined with low pricing. They are ideally suited to instrumentation applications where large production volumes are likely. A comprehensive programme of drives, power supplies and controllers are available for the small volume user to construct advanced single and multi-axis positioning systems.



### Dimensions:

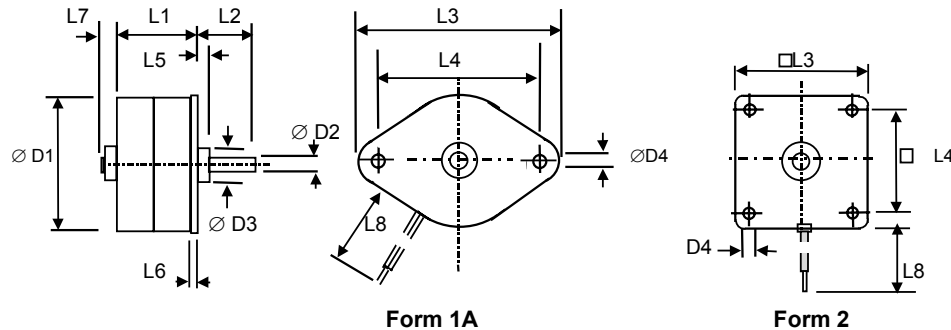

motor type	form	dimensions mm											
		D1	D2	D3	D4	L1	L2	L3	L4	L5	L6	L7	L8
15M020D	1 A	15.01	1.5	5.97	2.2	15.11	10	24	20	1.5	0.8	2.1	90
26S024B	1 A	26.2	2.0	7.92	3.3	13.3	12.7	42.8	35	3.8	0.8	Nil	191
26M048B	1 A			10		13.72	11.3			1.52		3.4	
35L048B	1 A	36	2.0	10	3.2	21.1	11.3	50	42	1.8	0.8	2	191
42M048C	1 A	42	3.0	10	3.5	22.0	11.4	56.5	49.5	1.52	0.8	3.5	305
60L048B	1 A	59.2	6.35	12	4.3	37.9	19.1	79.4	66.68	2.0	1.6	Nil	305
42M100B-2U	2	42	3.0	10	3.5	15.5	11.4	42	35	1.52	0.8	3.4	305
42M100B-1U	1 A	42	3.0	10	3.5	15.5	11.4	56.5	49.48	1.52	0.8	3.4	305
MV82801	2	59.2	6.0	12	4.3	37.9	18	65	56	2.03	1.6	2.23	305

### Specification

motor type	step angle degrees	holding torque Ncm	rotor inertia Kgcm <sup>2</sup>	resistance per phase ohms	current per phase amps	inductance per phase mH	number of leads or terminals	mass gms
15M020D-1B	18	0.388	0.00011	40	0.125	14	4	14
26S024B-2U	15	0.5	0.00045	118	0.1	33.8	6	28
26M048B-2U	7.5	0.9	0.0011	110	0.1	36.5	6	28
26M048B-1U				19.6	0.25	5.3		
35L048B-2U	7.5	2.5	0.004	64	0.18	40	6	88
35L048B-1U	7.5	2.5	0.004	11	0.45	7.8	6	88
42M048C-2U	7.5	6.6	0.0134	52.4	0.23	51.7	6	144
42M048C-1U	7.5	6.6	0.0134	9.1	0.55	8.1	6	144
60L048B-2U	7.5	16.9	0.095	26.2	0.46	26.2	6	478
60L048B-1U	7.5	16.9	0.095	4.55	1.0	6.4	6	478
MV82801-P2	7.5	19.8	0.095	26	0.46	33	6	440
MV82801-P1	7.5	19.8	0.095	4.6	1.0	6	6	440
42M100B-2U	3.6	4.5	0.0118	75	0.16	37.7	6	87
42M100B-1U	3.6	4.5	0.0118	12.5	0.40	6.6	6	87

**note** The above motors are 4 phase units suitable for use with uni-polar or bi-polar drive circuits with the exception of the 15M029D-1B motor which is designed specifically for Bi-polar operation .  
Bi-polar versions of the other motors in the range are available to special order.

# Typical permanent magnet stepper motor performance

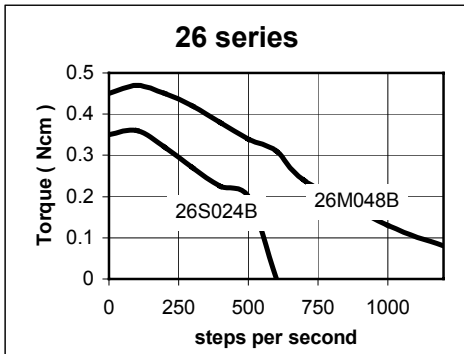

Uni-polar drive

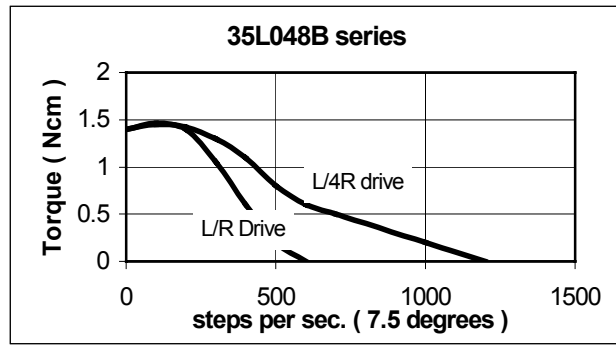

Uni-polar drive

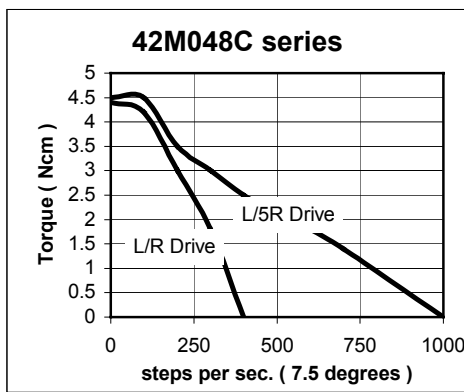

Uni-polar drive

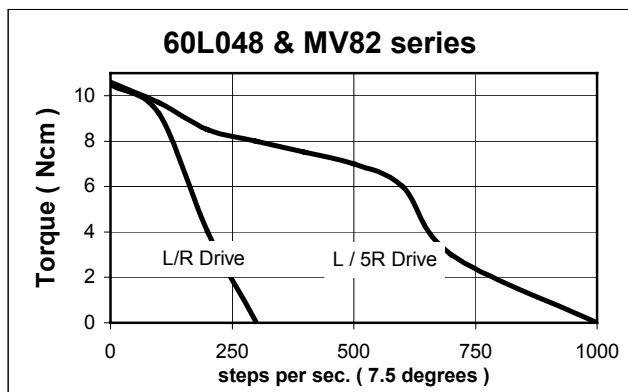

Uni-polar drive

Suitable modular drives for above motors: **MSE422, PVP134, PM542**

## Explanation of terminology

The motors may be connected directly to a dc supply of the same value as the motor rating. For example, the 35L048B-2U motor is a 12 Volt rated unit and therefore may be connected directly to a 12 Vdc supply as shown in Fig 1. This is often referred to as **L/R Drive**

For increased high speed performance however it is quite usual to connect the motor to a higher supply voltage via series resistors since the current rise time in the motor's coils is proportional to the inductance ( L ) divided by the resistance ( R ) in the drive circuit.

For example, the 42M048C-1U motor is a 5 Volt rated unit. When connected to a 24 Vdc supply via series resistors the ratio of inductance/ resistance will be greatly improved. In this case the system, as shown in Fig 2 would approximate an **L/5R** drive.

Alternatively a more sophisticated drive system can be employed using chopped constant current techniques when the series resistors are not required. A suitable drive of this type is PM542

