

ST Stepper Drives



A Performance Step Drive with 3 Control Options for OEM Applications

- ✓ **Advanced Current Control**
- ✓ **Anti-Resonance**
- ✓ **Torque Ripple Smoothing**
- ✓ **Microstep Emulation**

Specifications

POWER SUPPLY:

- ST5 24-48 VDC
- ST10 24-80 VDC

OUTPUT CURRENT:

- ST5 0.1 - 5.0A Peak
- ST10 0.1 - 10.0A Peak

PROTECTION:

- Over-Voltage
- Under voltage
- Over-Temp
- Motor Shorts
- Motor Open Phase

Models

S

- Pulse & Direction
- CW/CCW Pulse
- A/B Quadrature
- Velocity (Oscillator) mode
- Host commands (SCL compatible)
- SiNet Hub compatible
- ST Configurator software for setup

Q

- Stand-alone Operation
- Q Programmer for complex motion
- Conditional Processing
- Math Functions
- Multi-tasking
- Register Manipulation
- Encoder Following
- "Generic" HMI compatibility

Si

- Si Programmer with built-in Configurator
- Point-and-click indexing software
- User Friendly GUI
- I/O and motion programming
- MMI-01 compatibility

Ordering

ST5-Si-RE

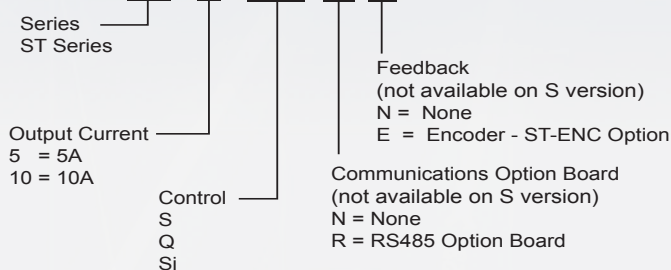

For more information go to
www.applied-motion.com/ST

S Models

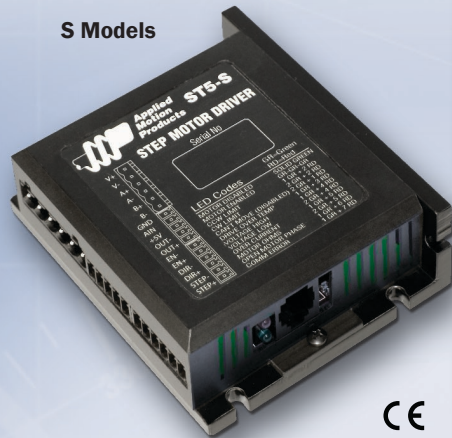

Q & Si Models

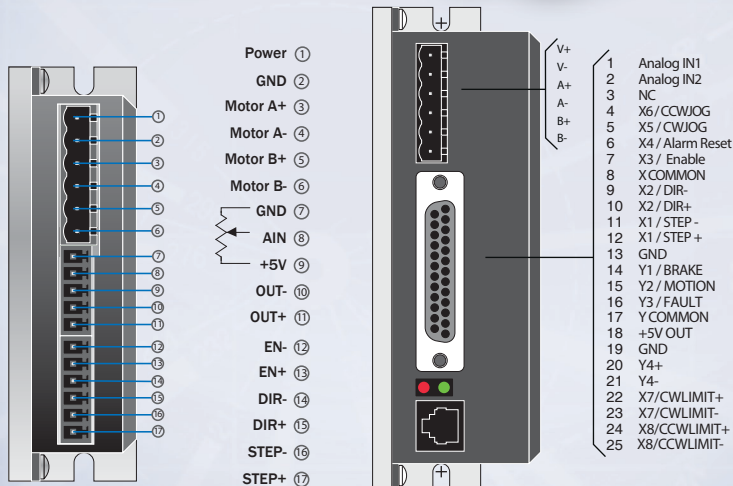

Option Boards

The Q and Si models can be fitted with option boards to give the following functions:

- **ST-ENC** - Encoder Feedback Option.
- **ST-485** - RS485 Option.

The ST-ENC encoder feedback option board provides the following functionality:

- **Stall Detect:** The drive detects if the motor has stalled and triggers a fault.
- **Stall Prevention:** The drive automatically senses rotor lag and reduces motor speed to avoid stalling. This feature also includes "Position Maintenance" which is used when the motor is stopped.



Features

Anti-Resonance/Electronic Damping

Step motor systems have a natural tendency to resonate at certain speeds. The ST drives automatically calculate the system's natural frequency and apply damping to the control algorithm. This greatly improves midrange stability, allows higher speeds and greater torque utilization, and also improves settling times.

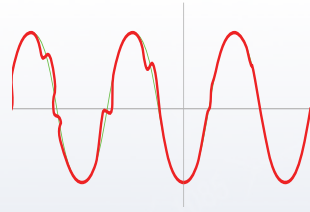

Delivers better motor performance and higher speeds

Microstep Emulation

With Microstep Emulation, low resolution systems can still provide smooth motion. The drive can take low-resolution step pulses and create fine resolution micro-step motion.

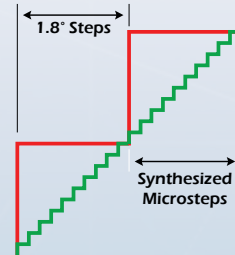

Delivers smoother motion in any application

Torque Ripple Smoothing

All step motors have an inherent low speed torque ripple that can affect the motion of the motor. By analyzing this torque ripple the system can apply a negative harmonic to negate this effect, which gives the motor much smoother motion at low speed.

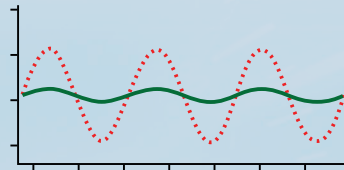

Delivers smoother motion at lower speeds

Command Signal Smoothing

Command Signal smoothing can soften the effect of immediate changes in velocity and direction, making the motion of the motor less jerky. An added advantage is that it can reduce the wear on mechanical components.

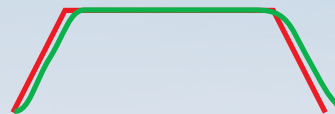

Delivers smoother system performance

Self Test & Auto Setup

At start-up the drive measures motor parameters, including the resistance and inductance, then uses this information to optimize the system performance. It also compares this information to the last configuration and checks to see if the motor data has changed (this could indicate a fault or system change). The drive can also detect open and short circuits.

Inputs & Outputs

S

3 digital inputs
1 digital output
1 analog input

Q

8 digital inputs
4 digital outputs
2 analog inputs

Si

8 digital inputs
4 digital outputs

Control Options

Step & Direction

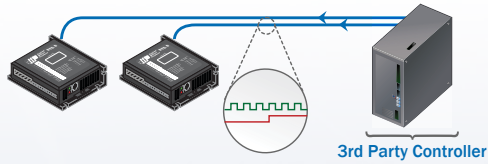

S

- Step & Direction
- CW & CCW Pulse
- A/B Quadrature (Master Encoder)

Oscillator / Run-Stop



S

- Software Configuration
- Two Speeds
- Vary speed with analog input
- Joystick Compatible

Host Control



S

- Accepts Serial Commands from host PC or PLC

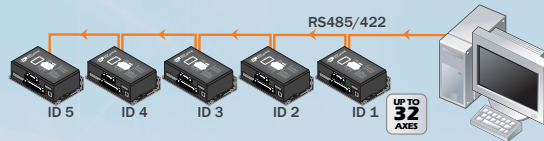

Q Si

- Accepts Serial Commands from host PC or PLC
- Multi-axis Capable (with RS 485 option)

Stand-Alone Programmable

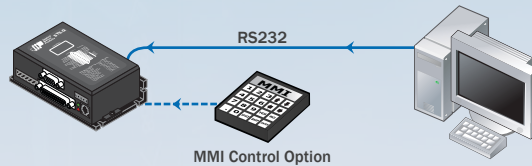

Si

- Point & Click Graphical Interface
- MMI Option
- Download, store & execute programs

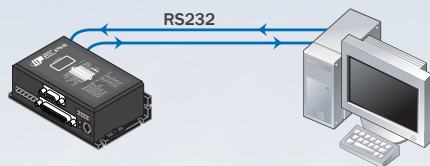

Q

- Comprehensive text based language
- Download, store & execute programs
- High Level Features: Multi-Tasking, Conditional Programming, & Math Functions
- Host Interface While Executing Internal programs

Multi-axis Systems

S Q Si

Use SiNet Hub Programmer software to develop your sequence of events, then download them to a SiNet Hub for a stand-alone system or stream serial commands to the drives from a PC, PLC, HMI, or other host controller.

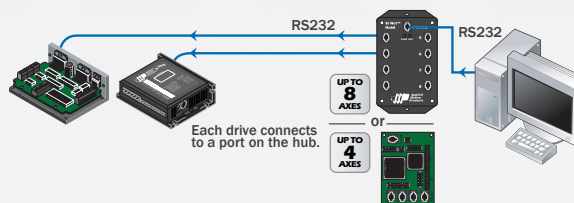

Specifications

POWER AMPLIFIER: All Models

AMPLIFIER TYPE	Dual H-Bridge, 4 Quadrant
CURRENT CONTROL	4 state PWM at 20 KHz
OUTPUT CURRENT	ST5 Series 0.1 – 5.0 amps/phase in 0.01 amp increments ST10 Series 0.1 – 10.0 amps/phase in 0.01 amp increments
POWER SUPPLY	ST5 Series External 24 - 48 VDC Power Supply Required ST10 Series External 24 - 80 VDC Power Supply Required
INPUT VOLTAGE RANGE	ST5 Series 18 - 53 VDC ST10 Series 18 - 88 VDC
PROTECTION	Over-Voltage, Under-voltage, Over-Temp, Motor/wiring shorts (Phase-to-Phase, Phase-to-Ground).
IDLE CURRENT REDUCTION	Reduction range of "0 – 90%" of "Running Current" after delay selectable in milliseconds.
AMBIENT TEMPERATURE	0 to 55 °C (32 - 158 °F) (ST10 must be mounted to suitable heatsink)
HUMIDITY	90% non-condensing.

CONTROLLER: All Models

MICROSTEP RESOLUTION	Software selectable from 200 to 51200 steps/rev in increments of 2 steps/rev.
ANTI-RESONANCE (Electronic Damping)	Raises the system damping ratio to eliminate midrange instability and allow stable operation throughout the speed range and improves settling time.
TORQUE RIPPLE SMOOTHING	Allows for fine adjustment of phase current waveform harmonic content to reduce low-speed torque ripple in the range 0.25 to 1.5 rps
AUTO SETUP	Measures motor parameters and configures motor current control and anti-resonance gain settings
SELF TEST	Checks Internal & External Power supply voltages. Diagnoses open motor phases and motor resistance changes >40%. Detects encoder wiring and signal faults (differential encoder only).
MICROSTEP EMULATION	Performs high resolution stepping by synthesizing fine microsteps from coarse steps (Step & Direction Mode Only) .
COMMAND SIGNAL SMOOTHING	Software configurable filtering reduces jerk and excitation of extraneous system resonances (Step & Direction Mode Only).

CONTROLLER: S Models

NON-VOLATILE STORAGE	Configurations are saved in FLASH memory on-board the DSP.
MODE OF OPERATION	Step & Direction, CW/CCW, A/B Quadrature, Oscillator, Joystick, SCL, Hub.
STEP AND DIRECTION INPUTS	Optically Isolated, Differential, 5 Volt. Minimum pulse width = 250 ns. Maximum pulse frequency = 2 MHz Function: Step & Direction, CW/CCW Step, A/B Quadrature, Run/Stop & Direction, Jog CW & CCW or CW & CCW Limits / Adjustable bandwidth digital noise rejection filter.
ENABLE INPUT	Optically Isolated, 5-12 Volt Function: Motor Enable, Alarm Reset or Speed Select (Oscillator Mode).
OUTPUT	Optically Isolated, 24V, 10mA MAX. Function: Fault, Motion, Tach.
ANALOG INPUT RANGE	0 to 5VDC
ANALOG INPUT RESOLUTION	12 bits
COMMUNICATION INTERFACE	RS-232

Specifications (cont)

CONTROLLER: Q & Si Models Only

NON-VOLATILE STORAGE	Programs, Data and drive configuration are saved in FLASH and EEPROM memory
INPUTS	X1, X2 Optically Isolated, Differential, 5 Volt. Minimum pulse width = 250 ns. Maximum pulse frequency = 2 MHz, Function: Step & Direction, CW/CCW Step, A/B Quadrature, Encoder Following, Sensor, Home or Branch Select X3 Optically isolated, 12 - 24V, sourcing or sinking, Function: Motor Enable, Sensor, Home or Branch Select X4 Optically isolated, 12 - 24V, sourcing or sinking, Function: Alarm Reset, Sensor, Home or Branch Select X5, X6 Optically isolated, 12 - 24V, sourcing or sinking, Function: Jogging, Sensor, Home or Branch Select NOTE: Inputs X3 - X6 have a shared "Common" X7, X8 Optically isolated, differential, 12 - 24V Function: CW & CCW Limits, Sensor, Home or Branch Select
OUTPUTS	Y1 Optical darlington, 30V, 100mA max, NPN/sinking. Function: General purpose programmable. Y2 Optical darlington, 30V, 100mA max, NPN/sinking. Function: Motion, tach or general purpose programmable Y3 Optical darlington, 30V, 100mA max, NPN/sinking. Function: Fault or general purpose programmable. NOTE - Y1, Y2 & Y3 have a shared common. Y4 Optical darlington, 30V, 100mA max, configurable as sinking or sourcing. Function: general purpose programmable
TWO ANALOG INPUTS	RANGE: Software selectable: 0-5V, $\pm 5V$, 0-10V, $\pm 10V$ RESOLUTION: 12 bits (with $\pm 10V$ signal range) 11 bits (with 0-10V or $\pm 5V$ signal range) 10 bits (with 0-5V signal range)
ENCODER OPTION	Differential line receivers suitable rates to 2MHz. Employs encoder to provide STALL DETECTION and STALL PREVENTION with static position maintenance.
COMMUNICATION INTERFACE	RS-232 standard, optional RS-485
AGENCY APPROVALS	RoHS, CE, EN 61800-3 :2004, EN 61800-5-1 :2003

Dimensions

S Models

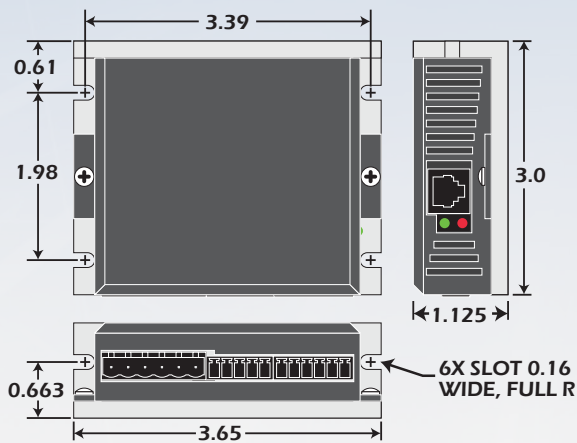

Q & Si Models

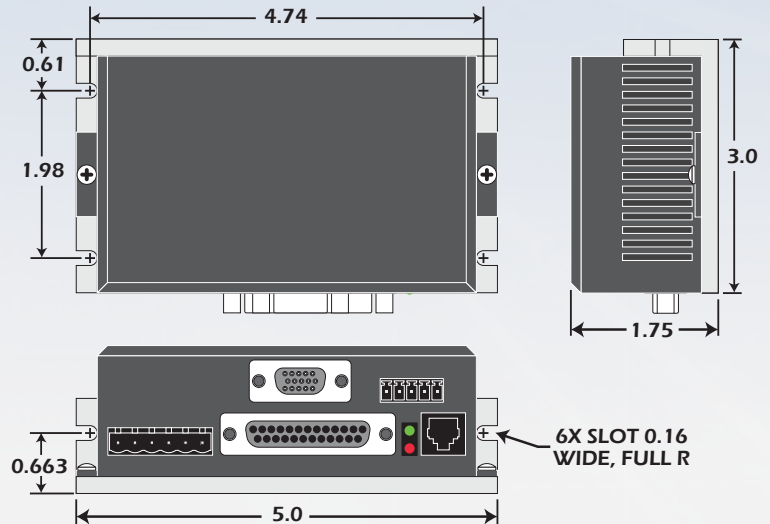

Dimensions in Inches
Not to scale

ST5 - TORQUE CURVES

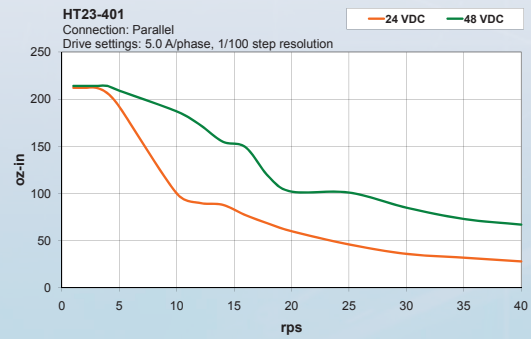
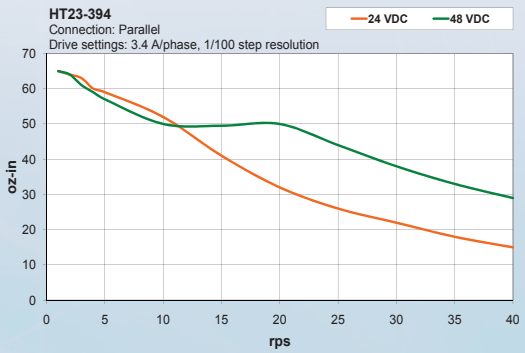
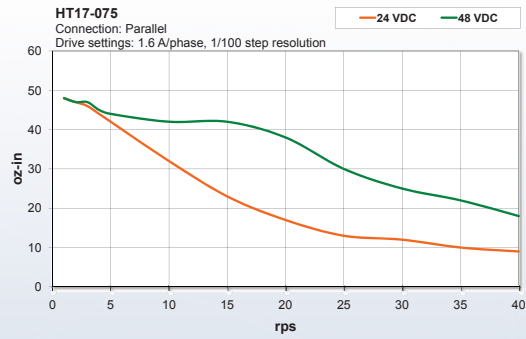
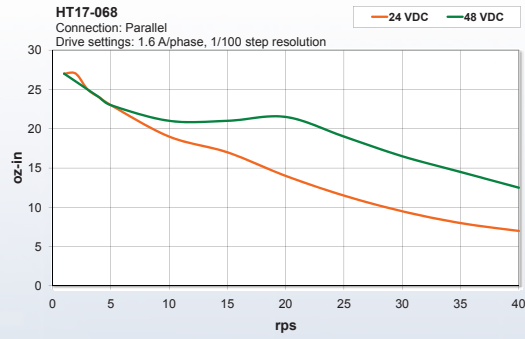

ST10 - TORQUE CURVES

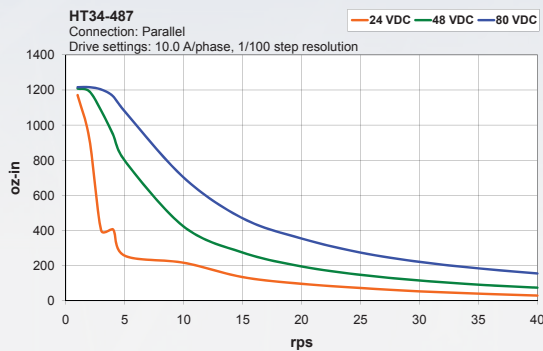
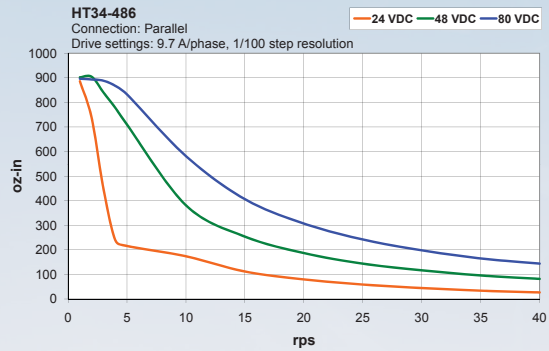
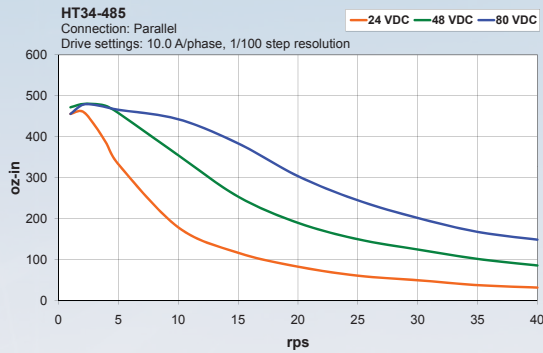

NEMA 17 - HIGH TORQUE

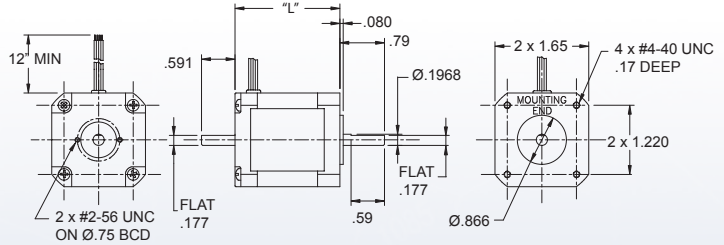
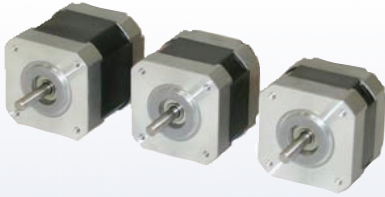

PART #	CONNECTION	MOTOR LENGTH (INCH)	MIN-HOLDING TORQUE (OZ-IN)*	# OF LEADS	STEP ANGLE (DEG)	AMPS*#	OHMS*	MH*	ROTOR INERTIA (OZ-IN ² / G-CM ²)	MOTOR WEIGHT (LBS.)
HT17-068	parallel	1.3	31.4	8	1.8	1.34	2.1	2.8	0.190/35	0.44
HT17-071	parallel	1.54	51.0	8	1.8	1.70	1.7	3.6	0.29/54	0.57

* Motor only rating.

optimal current setting in ST drive may differ.

NEMA 23 - HIGH TORQUE

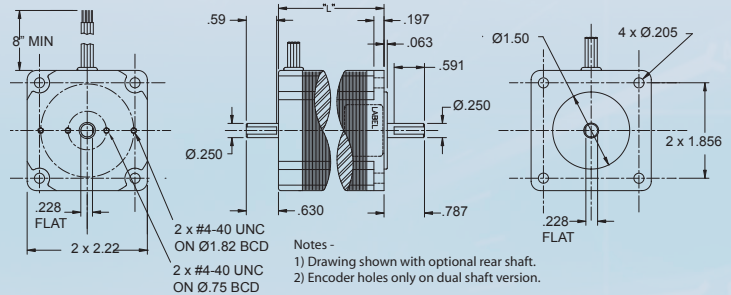
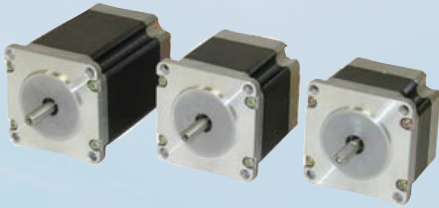

PART #	CONNECTION	MOTOR LENGTH (INCH)	MIN-HOLDING TORQUE (OZ-IN)*	# OF LEADS	STEP ANGLE (DEG)	AMPS*#	OHMS*	MH*	ROTOR INERTIA (OZ-IN ² / G-CM ²)	MOTOR WEIGHT (LBS.)
HT23-394	parallel	1.54	76.6	8	1.8	2.83	0.7	1.4	0.66 / 120	1.00
HT23-401	parallel	2.99	264.0	8	18	4.24	0.5	1.6	2.62 / 480	2.20

* Motor only rating.

optimal current setting in ST drive may differ.

NEMA 34 - HIGH TORQUE

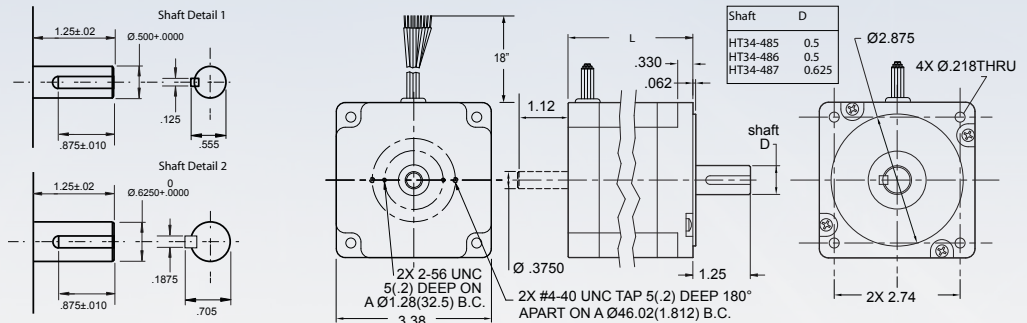

PART #	CONNECTION	MOTOR LENGTH (INCH)	MIN-HOLDING TORQUE (OZ-IN)*	# OF LEADS	STEP ANGLE (DEG)	AMPS*#	OHMS*	MH*	ROTOR INERTIA (OZ-IN ² / G-CM ²)	MOTOR WEIGHT (LBS.)
HT34-485	parallel	3.11	650	8	1.8	8.6	0.19	1.3	7.8 / 1400	6.18
HT34-486	parallel	4.63	1200	8	1.8	8.1	0.27	2.2	14.6 / 2680	8.40
HT34-487	parallel	6.14	1845	8	1.8	9.0	0.27	2.4	21.9/4000	11.9

* Motor only rating.

optimal current setting in ST drive may differ.

Step Motor Encoders

OPTIONAL STEP MOTOR ENCODERS

To maximize the advantages of the ST series drives fitted with the Encoder Feedback Option Board, Applied Motion Products offers step motors fitted with an optical encoder. Users can also provide their own encoder.

Encoder cables are also available, either to connect the motor to the ST and STAC series drives, or generic cables are offered for use with other controllers.

Please contact our applications team for details.

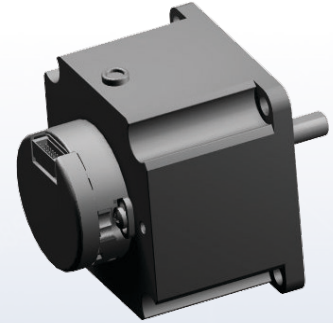

Software



ST Configurator

Used for setup, configuration of the drive. For more information about the ST Configurator visit the Applied-Motion Products Website

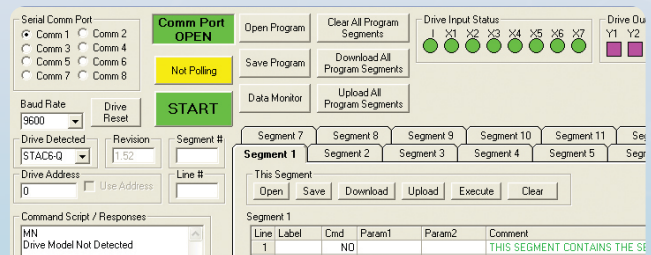

Q Programmer

Q Programmer is used to create and edit stand-alone programs for Q version drives. The functions of these drives include multi-tasking, math, register manipulation, encoder following, and more.

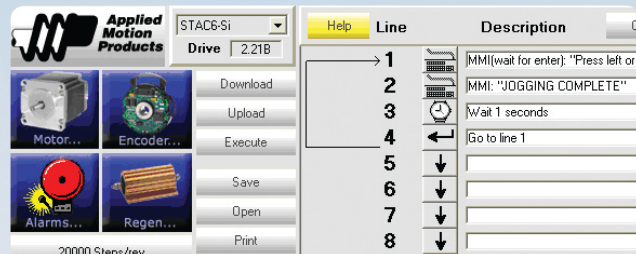

Si Programmer™

Intended for use in stand-alone applications, Si Programmer™ provides a user friendly, point-and-click, graphical interface that doesn't require any previous programming experience.



Help Manuals

ST Configurator incorporates new on-line help menus. All the technical data, application information and advice on setting up the drive is now just a mouse click away.

All software applications run on Windows Vista, XP, 2000, NT, ME, 98.

DISTRIBUTED BY:



Applied Motion Products

404 Westridge Dr.
Watsonville, CA 95076
Tel: 800-525-1609
Fax: 831-761-6544
www.applied-motion.com