

SIEMENS

SIRIUS

Sanftstarter 3RW40

Soft starter 3RW40

Démarrreur progressif 3RW40

Arrancador suave 3RW40

Avviatore dolce 3RW40

Chave de partida e parada suave 3RW40

Yumuşak Yol verici 3RW40

Устройство плавного пуска 3RW40

软启动器 3RW40

3RW40 2

3RW40 3

3RW40 4



EN/IEC 60947-4-2

DE	Sanftstarter 3RW40 Betriebsanleitung — Bestell-Nr.: 3ZX1012-0RW40-2DA1 Grafiken	Seite 2 - 4 29 - 32
EN	Soft starter 3RW40 Operating Instructions — Order No.: 3ZX1012-0RW40-2DA1 Graphics	Page 5 - 7 29 - 32
FR	Démarrreur progressif 3RW40 Instructions de service — N° de référence : 3ZX1012-0RW40-2DA1 Graphiques	Page 8 - 10 29 - 32
ES	Arrancador suave 3RW40 Instructivo — Referencia: 3ZX1012-0RW40-2DA1 Gráficos	Página 11 - 13 29 - 32
IT	Avviatore dolce 3RW40 Istruzioni operative — N° di ordinaz.: 3ZX1012-0RW40-2DA1 Grafiche	Pagina 14 - 16 29 - 32
PT	Chave de partida e parada suave 3RW40 Instruções de Serviço — N° de enc.: 3ZX1012-0RW40-2DA1 Gráficos	Página 17 - 19 29 - 32
TR	Yumuşak Yol verici 3RW40 İşletme kılavuzu — Sipariş no.: 3ZX1012-0RW40-2DA1 grafikler	Sayfa 20 - 22 29 - 32
PY	Устройство плавного пуска 3RW40 Инструкция по эксплуатации — № для заказа: 3ZX1012-0RW40-2DA1 графики	Страница 23 - 25 29 - 32
中文	软启动器 3RW40 操作规程 - 订货号: 3ZX1012-0RW40-2DA1 图表	第 26-28 和 29-32 页

Technical Assistance:	Telephone: +49 (0) 911-895-5900 (8°° - 17°° CET)	Fax: +49 (0) 911-895-5907
	E-mail: technical-assistance@siemens.com	
	Internet: www.siemens.de/lowvoltage/technical-assistance	
Technical Support:	Telephone: +49 (0) 180 50 50 222	

Vor der Installation, dem Betrieb oder der Wartung des Geräts muss diese Anleitung gelesen und verstanden werden.

⚠ GEFAHR

Gefährliche Spannung. Lebensgefahr oder schwere Verletzungsgefahr.
Vor Beginn der Arbeiten Anlage und Gerät spannungsfrei schalten.

VORSICHT

Eine sichere Gerätefunktion ist nur mit zertifizierten Komponenten gewährleistet!

GEFAHR

Gefährliche Spannung. Lebensgefahr oder schwere Verletzungsgefahr.
Um elektrischen Stromschlag oder Verbrennungen zu vermeiden, dürfen die Klemmen des Motorsteuergeräts nicht berührt werden, wenn das Gerät mit Spannung versorgt wird. An den Ausgangsklemmen steht auch im AUS-Zustand des Motorsteuergeräts Spannung an.

Einbauabstände in Einzelaufstellung (Dicht-an-dicht-Aufstellung siehe Sanftstarter-Handbuch)

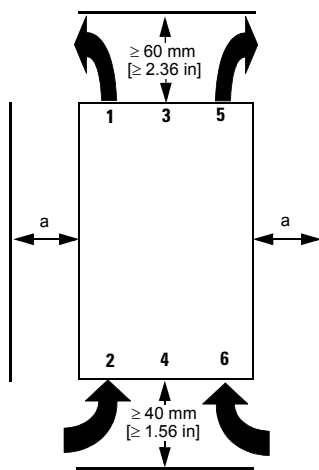

ACHTUNG

Beachten Sie beim Einbau des Geräts die angegebenen Abstände, damit genügend Luft für Kühlung zirkulieren kann. Das Gerät wird von unten nach oben belüftet.

VORSICHT

Gefahr von Sachschäden.
Achten Sie darauf, dass keine Flüssigkeit, kein Staub oder leitender Gegenstand in den Sanftstarter gelangt.

a) 3RW40 2: 15 mm [0.59 in]
3RW40 3; 3RW40 4: 30 mm [1.18 in]

Motorstromeinstellwerte

Zulässige Motorstromeinstellwerte in Abhängigkeit von der CLASS-Einstellung bei 40° C Umgebungstemperatur

	I_e [A]	I_{min} [A]	I_{max} [A] CLASS 10	I_{max} [A] CLASS 15	I_{max} [A] CLASS 20
3RW40 24-...	12,5	5	12,5	11	10
3RW40 26-...	25,3	10	25,3	23	21
3RW40 27-...	32,2	17	32,2	30	27
3RW40 28-...	38	23	38	34	31
3RW40 36-...	45	22,5	45	42	38
3RW40 37-...	63	25,5	63	50	46
3RW40 38-...	72	34,5	72	56	50
3RW40 46-...	80	42,5	80	70	64
3RW40 47-...	106	46	106	84	77

Programmieren des ON/RUN Ausgangs 13/14 (Werkseinstellung: ON) (Grafikteil, Bild 3)

- Programmierung starten:** (Beim Gerät 3RW40 2 die Abdeckung wie in Bild 2 gezeigt entfernen.) Die Taste "RESET MODE" (2) länger als 2 s drücken, bis die LED "DEVICE" (5) grün flimmert. Die Taste "RESET MODE" (2) gedrückt halten und zusätzlich die Taste "RESET/TEST" (1) länger als 1 s drücken, bis die LED "DEVICE" (5) am Gerät rot leuchtet.
- Modus anzeigen:** LED "STATE/BYPASSED/FAILURE" (6) blinkt grün: ON-Modus. LED "STATE/BYPASSED/FAILURE" (6) flimmert grün: RUN-Modus.
- Modus wechseln:** Taste "RESET MODE" (2) drücken.
- Programmierung beenden und Einstellungen speichern:** Taste "RESET/TEST" (1) länger als 1 s drücken, bis die LED "DEVICE" (5) grün leuchtet.

Schnellinbetriebnahmeanleitung

Thermistoranschluss (nur 3RW40.-TB0.)

- Anschluss Thermoclick gemäß Bild 6.3 (Drahtbrücke entfernen)
- Anschluss PTC Typ A gemäß Bild 6.4 (Drahtbrücke entfernen)

VORSICHT
Gefahr von Sachschäden!
 Anschluss an nicht belegte Klemmen ist unzulässig.

Einstellungsvorschlag	Anlauf Parameter			Auslauf Parameter
	Startspannung %	Anlaufzeit s	Strombegrenzungswert	Auslaufzeit s
Applikation				
Förderband	70	10	5 x I _e	5
Rollenförderer	60	10	5 x I _e	5
Kompressor	50	10	4 x I _e	0
kleiner Ventilator	40	10	4 x I _e	0
Pumpe	40	10	4 x I _e	10
Hydraulikpumpe	40	10	4 x I _e	0
Rührwerk	40	20	4 x I _e	0
Fräsmaschine	40	20	4 x I _e	0

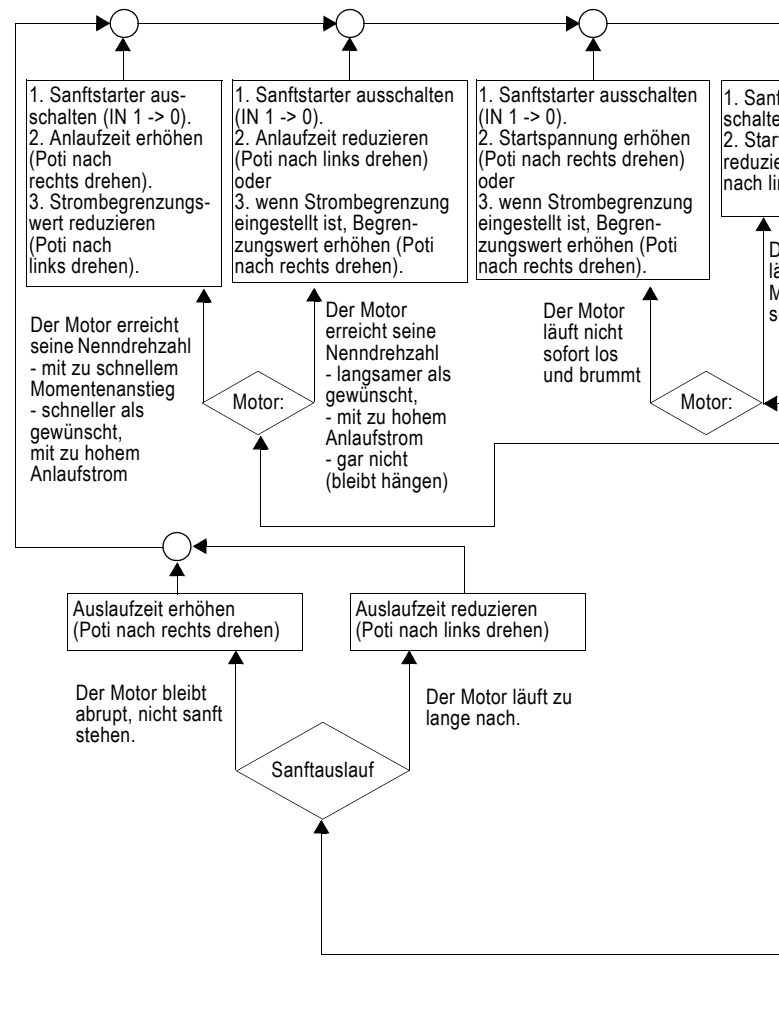
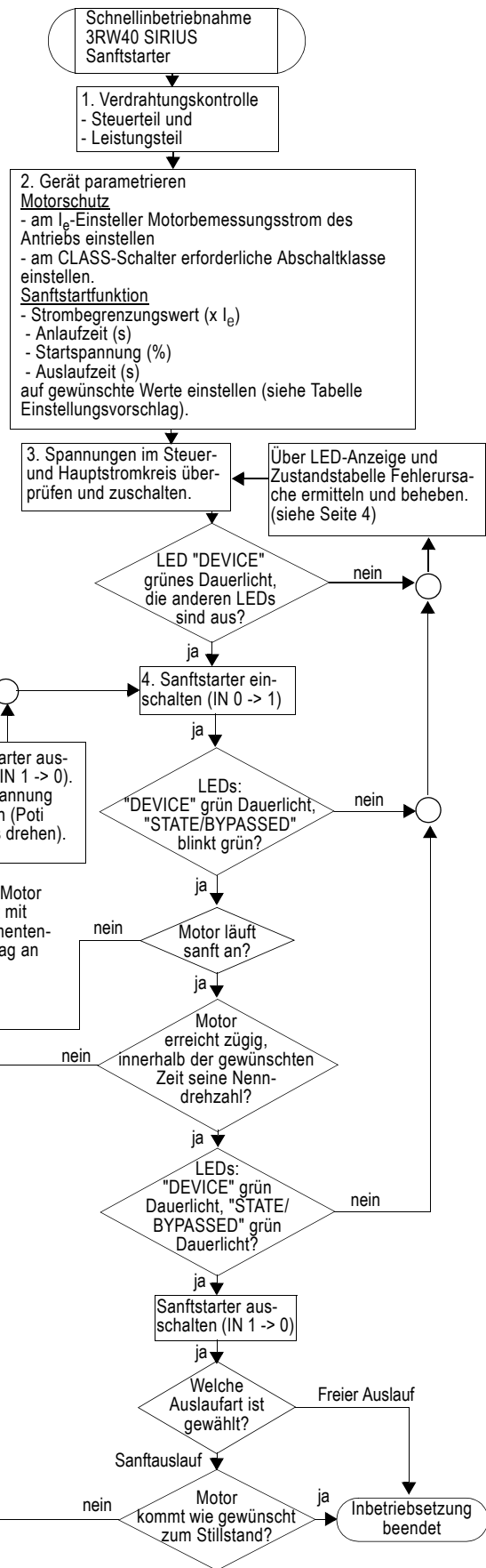

Anzeigenübersicht

		LED-Anzeigen 3RW40				Hilfskontakte			
		Sanftstarter		Motorschutz					
3RW40		DEVICE (rd/gn/ylw)	STATE / BYPASSED / FAILURE (gn/rd)	OVERLOAD (rd)	RESET MODE (ylw/gn)	13 14 (ON)	13 14 (RUN)	24 23 (BYPASSED)	96 95 98 FAILURE / OVERLOAD
U _s = 0		●	●	●	●				
Betriebszustand	IN								
Aus	0	gn	●	●					
Anlauf	1	gn	gn	●					
Bypassed	1	gn	gn	●					
Auslauf	0	gn	gn	●					
Warnung									
I _e /Class-Einstellung unzulässig		gn	gn / gn						
Start gesperrt, Gerät zu warm		ylw	●	●					
Fehler									
Versorgungsspannung Elektronik unzulässig		●	rd	●					
unzulässige I _e /Class-Einstellung und IN (0 -> 1)		gn	rd						
Motorschutzabschaltung Überlastrelais / Thermistor		gn	●						
Thermistormotorschutz Drahtbruch / Kurzschluss		gn	●						
Thermische Überlastung Gerät		ylw	rd	●					
- fehlende Lastspannung - Phasenausfall, fehlende Last		gn	rd	●					
Gerätefehler		rd	rd	●					
Testfunktion									
1) TEST t > 5 s drücken		gn	●	rd	●				
RESET MODE (Drücken zum Wechseln)									
Manual Reset					●				
Auto Reset					ylw				
Remote Reset siehe Bild 6.2					gn				

Anzeige der LEDs							1) Test Motorschutzabschaltung
				gn	ylw	rd	
aus	ein	blinkend	flimmernd	= grün	= gelb	= rot	

⚠️ WARNUNG

Automatischer Wiederanlauf.
Kann zu Tod, schwerer Körperverletzung oder Sachbeschädigung führen.

Der automatische Rücksetzmodus (RESET MODE) darf nicht in Anwendungen verwendet werden, in denen der unerwartete Neustart des Motors nach Ablauf der Wiederbereitschaftszeit zu Personen- oder Sachschäden führen kann.

Der Startbefehl (z. B. durch die SPS) muss vor einem Resetbefehl zurückgesetzt werden, da bei anstehendem Startbefehl nach dem Resetbefehl automatisch ein erneuter, selbsttätiger Wiederanlauf erfolgt. Dies gilt insbesondere bei Motorschutzauslösung. Aus Sicherheitsgründen wird empfohlen, den Sammelfehlerausgang (Klemmen 95 und 96) in die Steuerung einzubinden.

Read and understand these instructions before installing, operating, or maintaining the equipment.

DANGER



Hazardous voltage.
Will cause death or serious injury.
Disconnect power before working on equipment.



CAUTION

Reliable functioning of the equipment is only ensured with certified components.

DANGER

Dangerous voltage. Danger to life or danger of serious injury.
The terminals of the motor control device must not be touched when it is connected to a voltage in order to prevent electrical shocks or burning. The output terminals of the motor control device are connected to a voltage even when it is in the OFF state.

Stand-alone installation spacings (see soft starter manual for side-by-side installation)

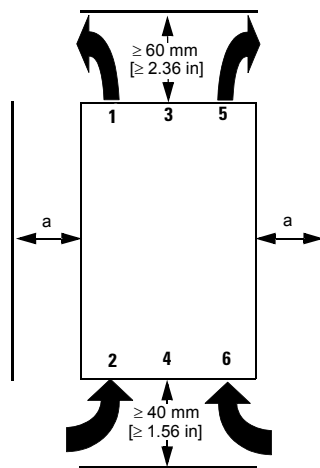

NOTICE

Please adhere to the specified spacings when installing the device so that sufficient air can circulate for ventilation. The unit is ventilated from bottom to top.

CAUTION

Risk of damage to property.
Ensure that no liquids, dust or conductive parts enter the soft starter.

a) 3RW40 2: 15 mm [0.59 in]
3RW40 3; 3RW40 4: 30 mm [1.18 in]

Setpoint values for motor current

Permitted setpoint values for the motor current, dependent on the CLASS setting at 40 °C ambient temperature

	I_e [A]	I_{min} [A]	I_{max} [A] CLASS 10	I_{max} [A] CLASS 15	I_{max} [A] CLASS 20
3RW40 24-...	12.5	5	12.5	11	10
3RW40 26-...	25.3	10	25.3	23	21
3RW40 27-...	32.2	17	32.2	30	27
3RW40 28-...	38	23	38	34	31
3RW40 36-...	45	22.5	45	42	38
3RW40 37-...	63	25.5	63	50	46
3RW40 38-...	72	34.5	72	56	50
3RW40 46-...	80	42.5	80	70	64
3RW40 47-...	106	46	106	84	77

Programming the ON/RUN output 13/14 (factory setting: ON) (Fig. 3 in graphics section)

- Start programming mode:** (For the 3RW40 2 device, remove the cover as shown in Figure 2.) Press and hold the "RESET MODE" button (2) for longer than 2 seconds until the LED "DEVICE" (5) flickers green. While pushing the "RESET MODE" button (2), press the "RESET/TEST" button (1) for longer than 1 second until the LED "DEVICE" (5) on the device lights up red.
- Display mode:** LED "STATE/BYPASSED/FAILURE" (6) flashes green: ON mode. LED "STATE/BYPASSED/FAILURE" (6) flickers green: RUN mode.
- Change mode:** Press the "RESET MODE" (2) button.
- Exit programming mode and save settings:** Press and hold the "RESET/TEST" button (1) for longer than 1 second until the LED "DEVICE" (5) lights up green.

Quick commissioning instructions

Thermistor connection (3RW40.-TB0. only)

- Thermoclick connection according to Fig. 6.3 (remove jumper)
- PTC connection type A according to Fig. 6.4

English

Quick commissioning of the 3RW40 SIRIUS soft starter

1. Wiring control
 - Control part and
 - Performance part

2. Configure device
 - Motor protection
 - Set the rated motor current of the device using the I_e controller
 - Set required switch-off class with the CLASS switch.
 - Set the soft start function
 - Current limit value ($\times I_e$)
 - Startup time (s)
 - Start voltage (%)
 - Stopping time (s)

3. Check and connect the voltages in the control and main circuits.

Determine and rectify the cause of the fault using the LED display and the status table (see Page 7).

CAUTION

Risk of damage to property!
Connection to an unassigned terminal is not permitted.

Suggested setting	Startup parameters			Stopping parameters
	Start voltage %	Startup time s	Current limit value	Stopping time s
Application				
Conveyor belt	70	10	$5 \times I_e$	5
Roller conveyor	60	10	$5 \times I_e$	5
Compressor	50	10	$4 \times I_e$	0
Small fan	40	10	$4 \times I_e$	0
Pumps	40	10	$4 \times I_e$	10
Hydraulic pump	40	10	$4 \times I_e$	0
Stirrers	40	20	$4 \times I_e$	0
Milling machines	40	20	$4 \times I_e$	0

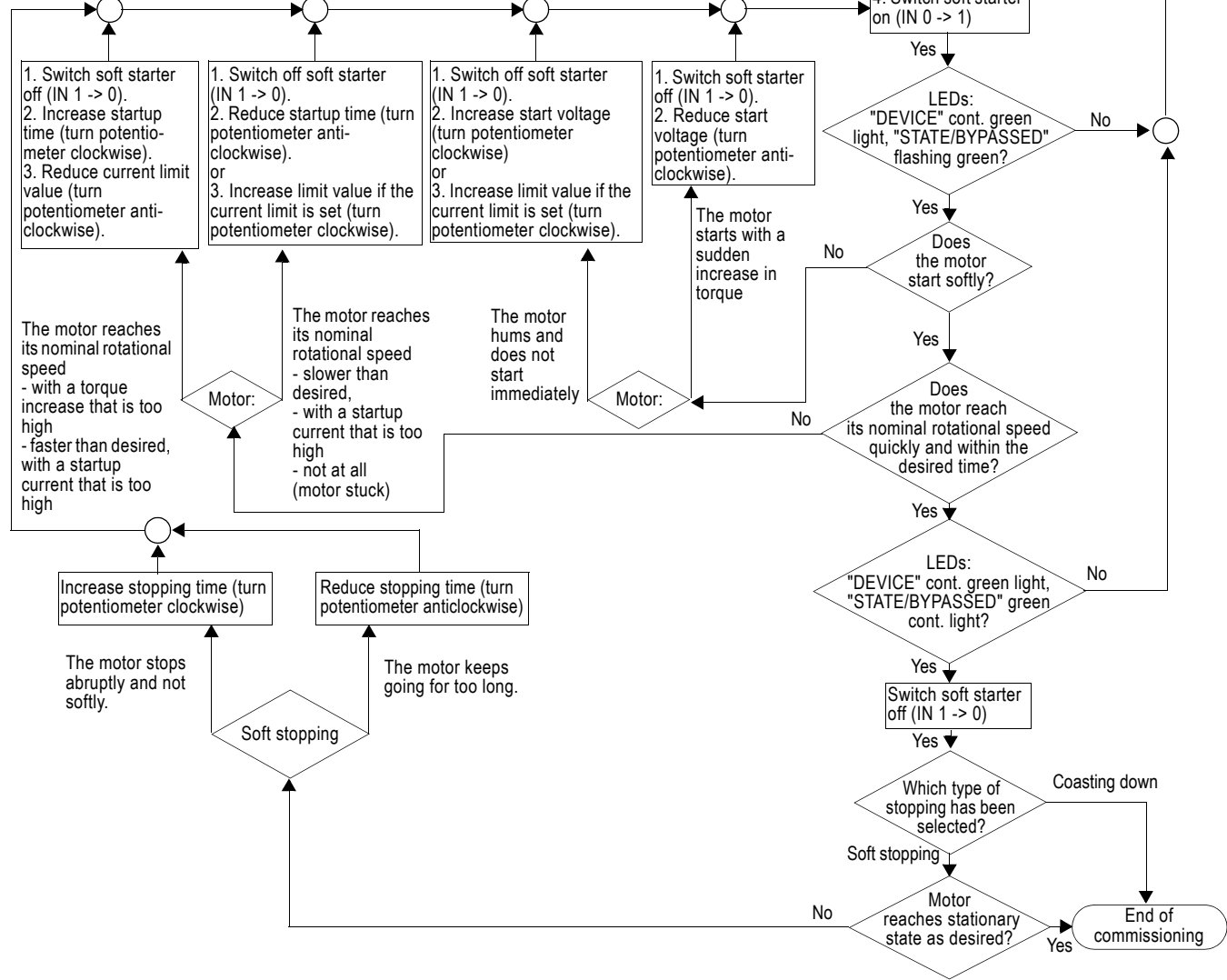

Display overview

		LED displays on 3RW40				Auxiliary contacts			
		Soft starter		Motor protection					
3RW40		DEVICE (rd/gn/ylw)	STATE / BYPASSED / FAILURE (gn/rd)	OVERLOAD (rd)	RESET MODE (ylw/gn)	13 14 (ON)	13 14 (RUN)	24 23 (BYPASSED)	96 95 98 FAILURE / OVERLOAD
$U_s = 0$		●	●	●	●				
Operating state	IN								
OFF	0	gn	●	●					
Start-up	1	gn	gn	●					
Bypassed	1	gn	gn	●					
Run-out	0	gn	gn	●					
Warning									
le / class setting invalid		gn	gn						
Start-up locked, device too warm		ylw	●	●					
Error									
Supply voltage electronics invalid		●	rd	●					
Invalid le / class setting and IN (0 -> 1)		gn	rd						
Motor protection switch-off Overload relay / thermistor		gn	●						
Thermistor motor protection Wire break / short circuit		gn	●						
Thermal overload device		ylw	rd	●					
- Missing load voltage - Phase failure, no load		gn	rd	●					
Device fault									
Device fault		rd	rd	●					
Test function									
1) Press TEST for t > 5 s		gn	●	rd	●				
RESET MODE (press to change)									
Manual Reset					●				
Auto Reset					ylw				
Remote Reset see Fig. 6.2					gn				

LED display				gn	ylw	rd	1) Motor protection shutdown test
				=	=	=	
OFF	ON	flashing	flickering	green	yellow	red	

⚠ WARNING

Automatic restart.
May result in death, serious injury or damage to property.
 The automatic reset mode (RESET MODE) must not be used in applications where an unexpected restart of the motor after the recovery time has elapsed may lead to personal injury or damage to property.
 The start command (e.g. by the PLC) must be reset before a reset command, since an automatic restart is executed when a start command is pending after the reset command. This especially applies to motor protection tripping. For safety reasons we recommend you integrate the group fault output (terminals 95 and 96) into the control.

Ne pas installer, utiliser ou intervenir sur cet équipement avant d'avoir lu et assimilé ces instructions..

⚠ DANGER

Tension dangereuse. Danger de mort ou risque de blessures graves. Mettre hors tension avant d'intervenir sur l'appareil.

PRUDENCE

Le fonctionnement sûr de l'appareil n'est garanti qu'avec des composants certifiés.

DANGER

Tension dangereuse. Danger de mort ou danger de lésions graves.
 Il est interdit de toucher les bornes du bloc de commande du moteur lorsque l'appareil est sous tension pour éviter les chocs électriques ou les brûlures. Une tension est présente aux bornes de sortie même à l'ARRET du bloc de commande du moteur.

Distances de montage pour installation séparée (installation juxtaposée, voir le manuel Démarrateurs progressifs)

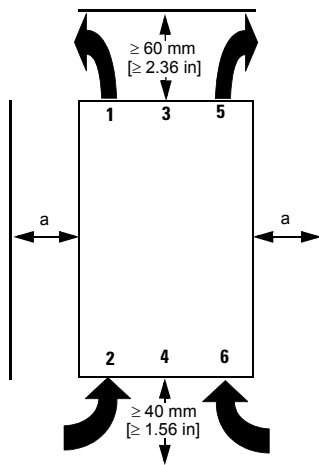

IMPORTANT

Veillez respecter au montage de l'appareil les distances indiquées pour assurer une circulation suffisante de l'air de refroidissement. L'appareil est ventilé du bas vers le haut.

PRUDENCE

Risque de dommages matériels.
 Veuillez à ce que ni liquide, ni poussière ou objet conducteur ne puisse pénétrer dans le démarreur progressif.

a) 3RW40 2 : 15 mm [0.59 in]
 3RW40 3 ; 3RW40 4 : 30 mm [1.18 in]

Valeurs de réglage du courant du moteur

Valeurs de réglage du courant du moteur admissible en fonction du CLASS à une température ambiante de 40° C

	I_e [A]	I_{min} [A]	I_{max} [A] CLASS 10	I_{max} [A] CLASS 15	I_{max} [A] CLASS 20
3RW40 24-...	12,5	5	12,5	11	10
3RW40 26-...	25,3	10	25,3	23	21
3RW40 27-...	32,2	17	32,2	30	27
3RW40 28-...	38	23	38	34	31
3RW40 36-...	45	22,5	45	42	38
3RW40 37-...	63	25,5	63	50	46
3RW40 38-...	72	34,5	72	56	50
3RW40 46-...	80	42,5	80	70	64
3RW40 47-...	106	46	106	84	77

Programmation de la sortie ON/RUN 13/14 (réglage standard : ON) (partie graphique, figure 3)

- Lancement de la programmation :** (retirez tout d'abord le couvercle de l'appareil 3RW40 2 comme le montre la figure 2.) Appuyez sur la touche "RESET MODE" (2) pendant plus de 2 secondes jusqu'à ce que la LED verte "DEVICE" (5) scintille. Maintenez la touche "RESET MODE" (2) appuyée et pressez la touche "RESET/TEST" (1) pendant plus de 1 s, jusqu'à ce que la LED rouge "DEVICE" (5) scintille sur l'appareil.
- Affichage du mode :** la LED verte "STATE/BYPASSED/FAILURE" (6) clignote : mode ON. La LED verte "STATE/BYPASSED/FAILURE" (6) scintille : mode RUN.
- Changement de mode :** appuyez sur la touche "RESET MODE" (2).
- Fin de la programmation et enregistrement des réglages :** appuyez sur la touche "RESET/TEST" (1) pendant plus d'1 seconde jusqu'à ce que la LED verte "DEVICE" (5) s'allume.

Instructions de mise en service rapide

Raccordement de thermistance (uniquement 3RW40.-TB0.)

- Raccordement du thermoclick selon la figure 6.3 (retirer les ponts à fil)
- Raccordement PTC type A selon la figure 6.4

PRUDENCE

Risque de dommages matériels !
Un raccordement aux bornes libres est inadmissible.

Proposition de réglage	Paramètres de démarrage			Paramètres de ralentissement
	Tension démarrage % 	Temps dém. s 	Val. limitation courant $\times I_e$ 	Temps ralent. s
Convoyeur	70	10	5 x I_e	5
Convoyeur à rouleaux	60	10	5 x I_e	5
Compresseur	50	10	4 x I_e	0
Petit ventilateur	40	10	4 x I_e	0
Pompe	40	10	4 x I_e	10
Pompe hydraulique	40	10	4 x I_e	0
Malaxeur	40	20	4 x I_e	0
Fraiseuse	40	20	4 x I_e	0

Mise en service rapide
3RW40 SIRIUS
démarreur progressif

1. Contrôle du câblage
- bloc de commande et
- bloc de puissance

2. Paramétrage de l'appareil
Protection moteur
- sur régleur I_e régler le courant assigné du moteur
- régler la classe de coupure nécessaire sur le commutateur CLASS.
Fonction démarreur progressif
- valeur limitation de courant ($\times I_e$)
- temps démarrage (s)
- tension de démarrage (%)
- temps de ralentissement (s)
à régler sur les valeurs souhaitées (voir le tableau Proposition de réglage).

3. Contrôler et mettre en circuit les tensions dans le circuit principal et de commande.
Déterminer et supprimer l'origine du défaut via l'affichage LED et la table des états. (voir Page 10)

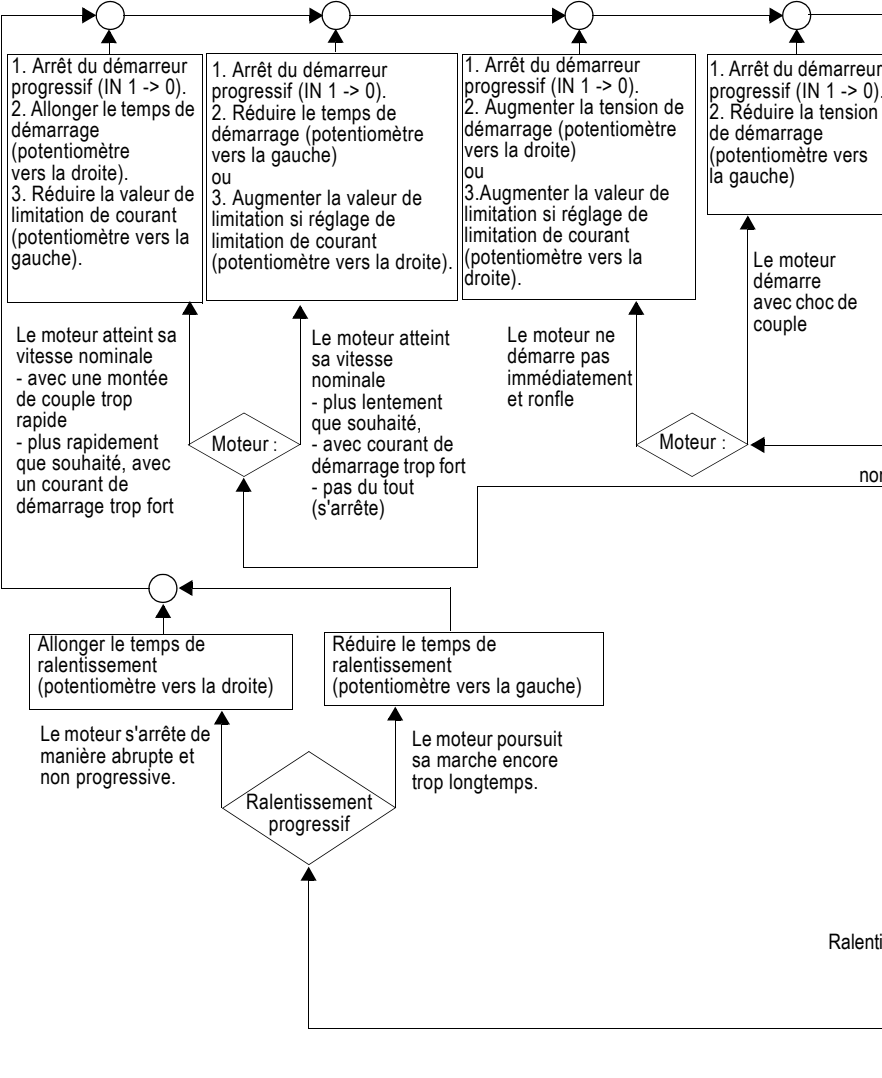
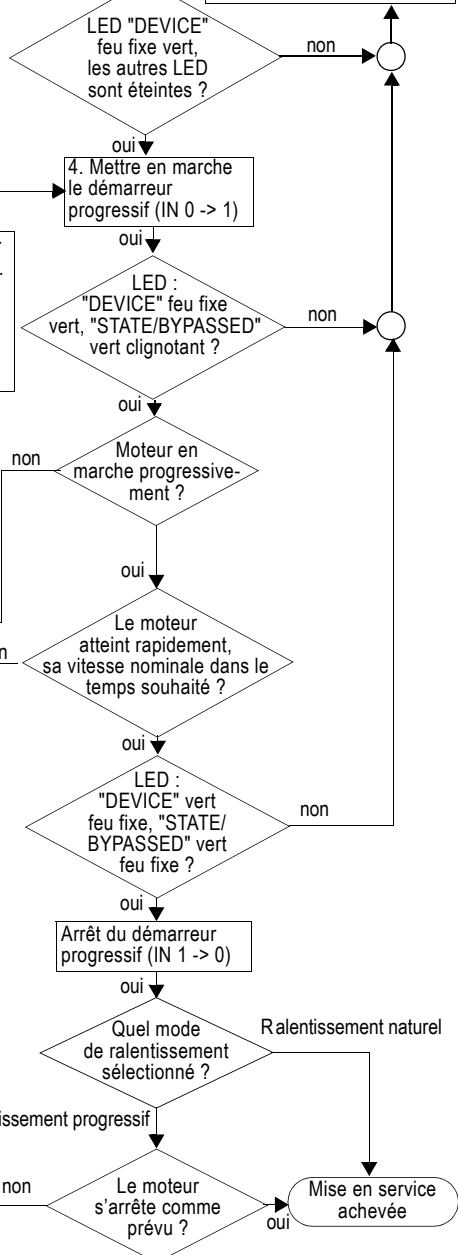

Vue d'ensemble des affichages

		LED de signalisation 3RW40				Contacts auxiliaires			
		Démarreur progressif		Protection moteur					
3RW40		DEVICE (rd/gn/ylw)	STATE / BYPASSED / FAILURE (gn/rd))	OVERLOAD (rd)	RESET MODE (ylw/gn)	13 14 (ON)	13 14 (RUN)	24 23 (BYPASSED)	96 95 98 FAILURE / OVERLOAD
U _s = 0		●	●	●	●				
Etat de fonctionnement	IN								
Arrêté	0		●	●					
Démarrage	1			●					
Bypassed	1			●					
Ralentissement	0			●					
Alarme									
Réglage le/Class incorrect									
Démarrage bloqué, appareil trop chaud			●	●					
Défauts									
Tension d'alimentation de l'électronique incorrecte		●		●					
Réglage le/Class incorrect et IN (0 -> 1)									
Coupure du moteur par protection Relais de surcharge / thermistance			●						
Protection des moteurs par thermistance Rupture de câble / court-circuit			●						
Surcharge thermique appareil				●					
- manque de tension de charge - coupure de phase, charge non raccordée				●					
Défaut sur l'appareil				●					
Fonction de test									
1) Appuyer sur TEST t > 5 s			●		●				
RESET MODE (appuyer pour changer)									
Reset manuel					●				
Reset automatique									
Remote Reset voir la figure 6.2									

Affichage des LED							
				gn = verte	ylw = jaune	rd = rouge	1) Test Coupure protection moteur
éteinte	allumée	clignotante	scintillante				

⚠ ATTENTION

Redémarrage automatique.
Peut causer la mort, des lésions graves ou des dommages matériels.

Le réarmement automatique (RESET MODE) ne peut être utilisé dans des applications où le redémarrage inattendu du moteur après le temps de récupération peut provoquer des lésions ou des dommages matériels importants. L'ordre de marche (de l'API par ex.) doit être annulé avant de donner l'ordre de réarmement ; en effet, la présence de l'ordre de marche à la suite du réarmement donne lieu à un redémarrage automatique. Ceci vaut tout particulièrement pour le déclenchement de protection du moteur. Pour des raisons de sécurité, il est recommandé d'intégrer la sortie de signalisation de défauts groupés (bornes 95 et 96) à la commande.

Français

Leer y comprender este instructivo antes de la instalación, operación o mantenimiento del equipo.

	PELIGRO	PRECAUCIÓN
	<p>Tensión peligrosa. Puede causar la muerte o lesiones graves. Desconectar la alimentación eléctrica antes de trabajar en el equipo.</p>	<p>El funcionamiento seguro del aparato sólo está garantizado con componentes certificados.</p>

PELIGRO

Tensión peligrosa. Puede causar la muerte o lesiones graves.
Para evitar todo riesgo de electrocución o de quemaduras, no tocar los bornes de la unidad de control del motor mientras estén bajo tensión. Los bornes de salida están bajo tensión aunque la unidad de control del motor esté desconectada.

Distancias de montaje para instalación simple (para instalación junto a otros aparatos, ver manual arrancadores suaves)

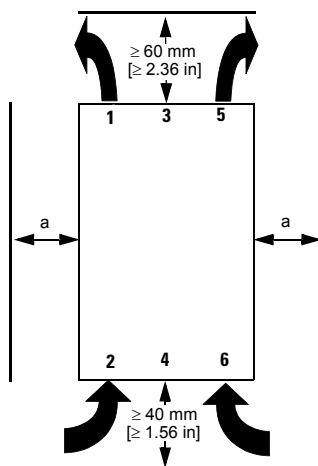

ATENCIÓN

Al instalar el equipo, obsérvese las distancias mínimas indicadas para garantizar la circulación del aire necesario para la refrigeración. La ventilación del equipo se realiza desde abajo hacia arriba.

PRECAUCIÓN

¡Peligro de daños materiales!
Preste atención de que no pueda ingresar líquido, polvo o algún objeto conductor al interno del arrancador suave.

a) 3RW40 2: 15 mm [0.59 in]
3RW40 3; 3RW40 4: 30 mm [1.18 in]

Valores de ajuste de la corriente del motor

Valores de ajuste admisibles de la corriente del motor en función del tipo CLASS a temperaturas ambiente de 40° C

	I_e [A]	I_{min} [A]	I_{max} [A] CLASS 10	I_{max} [A] CLASS 15	I_{max} [A] CLASS 20
3RW40 24-...	12,5	5	12,5	11	10
3RW40 26-...	25,3	10	25,3	23	21
3RW40 27-...	32,2	17	32,2	30	27
3RW40 28-...	38	23	38	34	31
3RW40 36-...	45	22,5	45	42	38
3RW40 37-...	63	25,5	63	50	46
3RW40 38-...	72	34,5	72	56	50
3RW40 46-...	80	42,5	80	70	64
3RW40 47-...	106	46	106	84	77

Programación de la salida ON/RUN 13/14 (ajuste de fábrica: ON) (parte de gráficas, figura 3)

- Iniciar programación:** (Al usar el equipo 3RW40 2, retire primero la tapa como demostrado en la figura 2.) Mantenga pulsada la tecla " RESET MODE" (2) durante más de 2 s, hasta que el LED "DEVICE" (5) parpadee en verde. Mantenga pulsada la tecla "RESET MODE" (2), pulsando al mismo tiempo la tecla "RESET/TEST" (1) durante más de 1 s, hasta que el LED "DEVICE" (5) del equipo se ilumine rojo.
- Indicar modo:** el LED "STATE/BYPASSED/FAILURE" (6) destella verde: modo ON. El LED "STATE/BYPASSED/FAILURE" (6) parpadea en verde: modo RUN.
- Cambiar modo:** pulse la tecla "RESET MODE" (2).
- Terminar programación y guardar ajustes:** mantenga pulsada la tecla " RESET/TEST" (1) durante más de 1 s, hasta que el LED "DEVICE" (5) se ilumine verde.

Español

Instrucciones para la puesta en servicio rápida

Entrada de termistor (sólo 3RW40.-TB0.)

- Conexión Thermoclick según figura 6.3 (quitar ligadura de alambre)
- Conexión PTC de tipo A según figura 6.4

Puesta en servicio rápida
3RW40 SIRIUS
Arrancador suave

1. Control del cableado
- parte de control y
- parte de potencia

2. Parametrizar el equipo
Protección del motor
- ajustar la corriente nominal del motor mediante el ajustador I_e
- seleccionar la clase de disparo mediante el selector CLASS
Función de arranque suave
- Valor límite de corriente ($\times I_e$)
- Tiempo de arranque (s)
- Tensión inicial (%)
- Tiempo de deceleración (s)
ajustar los valores deseados (ver tabla Propuesta de ajuste).

3. Controlar y aplicar tensiones en el circuito de mando y en el circuito principal.

Determinar y eliminar la causa del fallo mediante el indicador LED y la tabla de estado. (ver Página 13)

PRECAUCIÓN
¡Peligro de daños materiales!
No está admitida la conexión con bornes no ocupados.

Propuesta de ajuste	Parámetros de arranque			Parámetros de deceleración
	Tensión inicial % 	Tiempo de arranque s 	Valor límite de corriente $\times I_e$ 	Tiempo de deceleración s
Cinta transportadora	70	10	$5 \times I_e$	5
Transportador a rodillos	60	10	$5 \times I_e$	5
Compresor	50	10	$4 \times I_e$	0
Ventilador pequeño	40	10	$4 \times I_e$	0
Bomba	40	10	$4 \times I_e$	10
Bomba hidráulica	40	10	$4 \times I_e$	0
Mezcladora	40	20	$4 \times I_e$	0
Máquina fresadora	40	20	$4 \times I_e$	0

Español

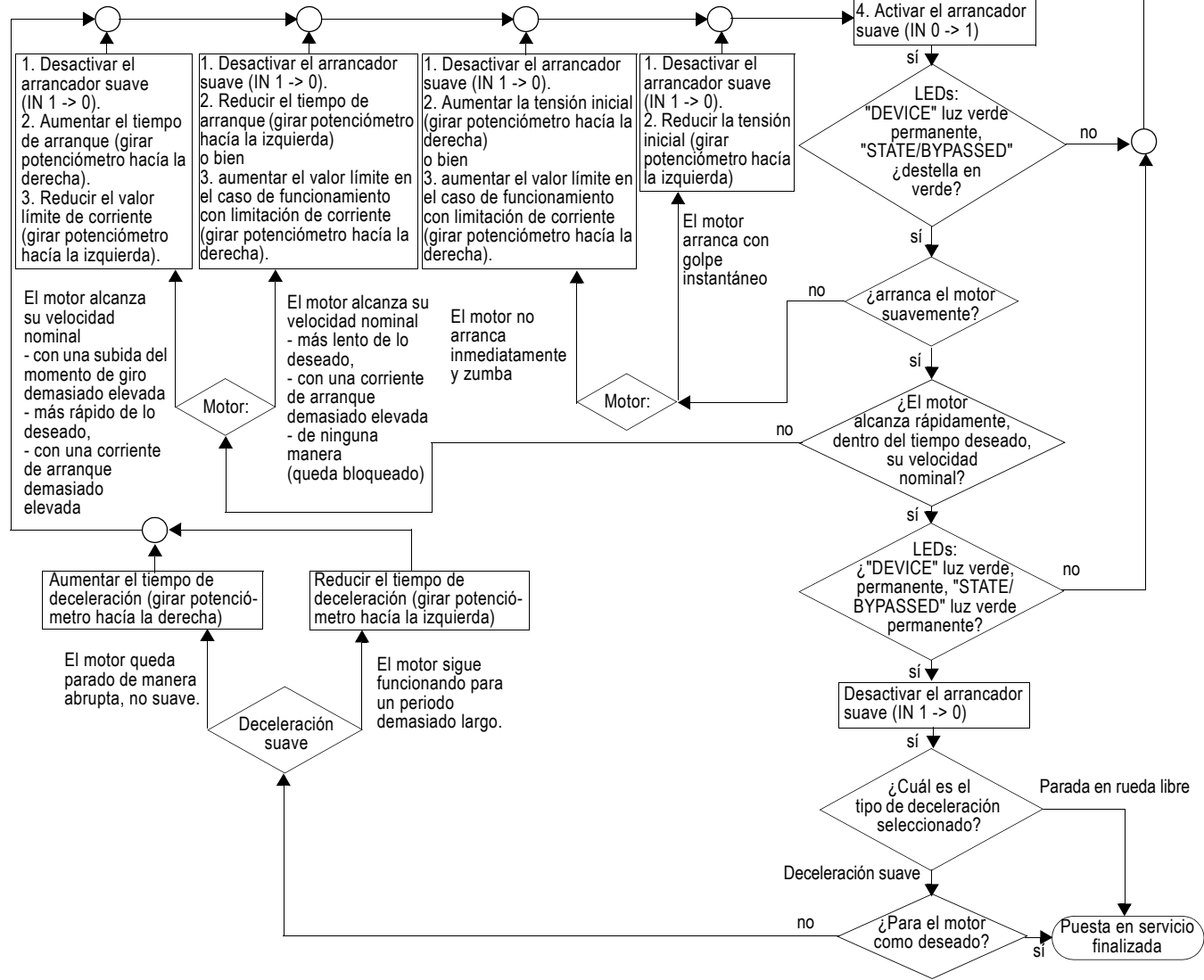

Resumen de las indicaciones

		Indicadores LED 3RW40				Contactos auxiliares			
		Arrancador suave		Protección del motor					
3RW40		DEVICE (rd/gn/ylw)	STATE / BYPASSED / FAILURE (gn/rd)	OVERLOAD (rd)	RESET MODE (ylw/gn)	13 14 (ON)	13 14 (RUN)	24 23 (BYPASSED)	96 95 98 FAILURE / OVERLOAD
$U_s = 0$		●	●	●	●				
Estado operativo	IN								
Desconectado	0		●	●					
Arranque	1			●					
Bypassed	1			●					
Deceleración	0			●					
Alarma									
Ajuste Ie/Class inadmisible									
Arranque bloqueado, sobrecalentamiento del equipo			●	●					
Fallo									
Tensión de alimentación de la electrónica inadmisible		●		●					
Ajuste Ie/Class inadmisible e IN (0 -> 1)									
Desconexión protección del motor Relé de sobrecarga / termistor			●						
Protección del motor del termistor Rotura de cable / cortocircuito			●						
Sobrecarga térmica del equipo				●					
- Falta tensión de carga - Corte de fase, falta carga				●					
Fallo del equipo				●					
Función de prueba									
1) Pulsar TEST t > 5 s			●		●				
RESET MODE (pulsar para cambiar)									
Reset manual					●				
Reset automático									
Reset remoto ver figura 6.2									

Indicación de los LEDs							1) Test desconexión protección motor
				gn =	ylw =	rd =	
Apagado	Encendido	Intermitente	Centelleante	verde	amarillo	rojo	

⚠ ADVERTENCIA

Rearranque automático.
Puede causar la muerte, lesiones graves o daños materiales.

No está permitido utilizar el modo automático de Reset (RESET MODE) en aplicaciones en las cuales el rearmado imprevisto después del tiempo de recuperación pueda provocar lesiones físicas o daños materiales. La orden de marcha (p. ej. por medio de la PLC) deberá anularse antes de una orden de rearme; en efecto, la presencia de la orden de marcha después de la orden de rearme provoca un rearmado automático. Esto es especialmente válido para el disparo de protección del motor. Por razones de seguridad se recomienda integrar la salida de señalización de fallo agrupado (bornes 95 y 96) en la unidad de control.

Leggere con attenzione queste istruzioni prima di installare, utilizzare o eseguire manutenzione su questa apparecchiatura.



PERICOLO
Tensione pericolosa.
Può provocare morte o lesioni gravi.
 Scollegare l'alimentazione prima di eseguire interventi sull'apparecchiatura.

CAUTELA
 Il funzionamento sicuro dell'apparecchiatura è garantito soltanto con componenti certificati.

PERICOLO
Tensione pericolosa. Pericolo di morte o di lesioni gravi.
 Per evitare folgorazioni o ustioni, i morsetti dell'avviatore non devono essere toccati quando l'apparecchiatura è sotto tensione. I morsetti di uscita sono sotto tensione anche quando l'avviatore è disinserito.

Distanze di montaggio nell'installazione singola (per l'installazione compatta vedi manuale avviatore dolce)

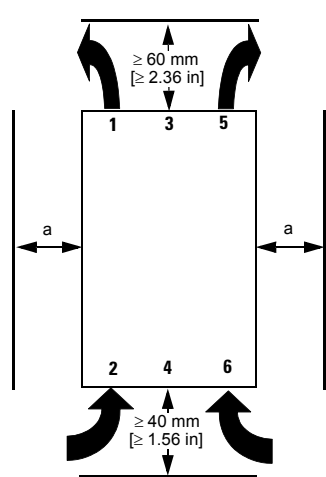

ATTENZIONE
 Durante il montaggio osservare le distanze indicate per consentire una circolazione sufficiente di aria di raffreddamento. L'apparecchio viene ventilato dal basso verso l'alto.

CAUTELA
Pericolo di danni alle cose.
 Evitare che liquidi, polvere o altri conduttori finiscano nell'avviatore dolce.

a) 3RW40 2: 15 mm [0.59 in]
 3RW40 3; 3RW40 4: 30 mm [1.18 in]

Valori di impostazione della corrente motore

Valori di impostazione della corrente motore a seconda del tipo di CLASS a 40° C temperatura ambiente

	I_e [A]	I_{min} [A]	I_{max} [A] CLASS 10	I_{max} [A] CLASS 15	I_{max} [A] CLASS 20
3RW40 24-...	12,5	5	12,5	11	10
3RW40 26-...	25,3	10	25,3	23	21
3RW40 27-...	32,2	17	32,2	30	27
3RW40 28-...	38	23	38	34	31
3RW40 36-...	45	22,5	45	42	38
3RW40 37-...	63	25,5	63	50	46
3RW40 38-...	72	34,5	72	56	50
3RW40 46-...	80	42,5	80	70	64
3RW40 47-...	106	46	106	84	77

Programmazione dell'uscita ON/RUN 13/14 (impostazione di fabbrica: ON) (grafiche, figura 3)

- Avvio della programmazione:** (nell'apparecchio 3RW40 2, rimuovere prima la copertura come indicato nella Figura 2.) Tenere premuto il tasto "RESET MODE" (2) per più di 2 secondi. Il LED "DEVICE" (5) verde sfarfalla. Tenere premuto il tasto "RESET MODE" (2) e premere allo stesso tempo il tasto "RESET/TEST" (1) per più di 1 secondo. Il LED "DEVICE" (5) rosso dell'apparecchio si illumina.
- Indicazione del modo:** il LED "STATE/BYPASSED/FAILURE" (6) lampeggia verde: modo ON. Il LED "STATE/BYPASSED/FAILURE" (6) sfarfalla verde: modo RUN.
- Cambio del modo:** premere il tasto "RESET MODE" (2).
- Fine della programmazione e salvataggio delle impostazioni:** tenere premuto il tasto "RESET/TEST" (1) per più di 1 secondo. Il LED "DEVICE" (5) verde illumina.

Italiano

Istruzioni per messa in servizio rapida

Collegamento termistore (solo 3RW40.-TB0.)

- Collegamento Thermoclick secondo Figura 6.3 (rimuovere ponte di filo)
- Collegamento PTC tipo A secondo Figura 6.4

CAUTELA
Pericolo di danni alle cose!
 Non è ammesso il collegamento a morsetti non assegnati.

Consiglio di installazione	Avvio parametri			Arresto parametri
	Applicazione	Tensione di avviamento %	Tempo di avviamento s	Valore di limitazione di corrente
Nastro trasportatore	70	10	5 x I _e	5
Trasportatore a rulli	60	10	5 x I _e	5
Compressore	50	10	4 x I _e	0
piccolo ventilatore	40	10	4 x I _e	0
Pompa	40	10	4 x I _e	10
Pompa idraulica	40	10	4 x I _e	0
Mescolatore	40	20	4 x I _e	0
Fresatrice	40	20	4 x I _e	0

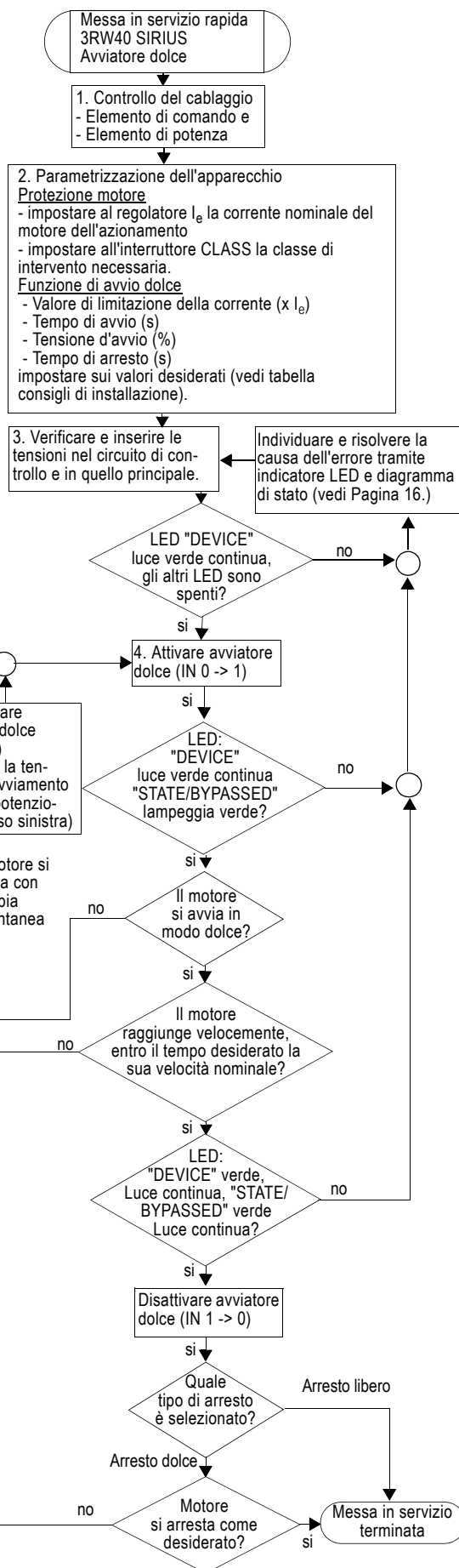

Italiano

Elenco delle visualizzazioni

		LED di segnalazione 3RW40				Contatti ausiliari			
		Avviatore dolce		Protezione motore					
3RW40		DEVICE (rd/gn/ylw)	STATE / BYPASSED / FAILURE (gn/rd)	OVERLOAD (rd)	RESET MODE (ylw/gn)	13 14 (ON)	13 14 (RUN)	24 23 (BYPASSED)	96 95 98 FAILURE / OVERLOAD
U _s = 0		●	●	●	●				
Stato operativo	IN								
OFF	0	gn	●	●					
Avviamento	1	gn	gn	●					
Bypassed	1	gn	gn	●					
Decelerazione	0	gn	gn	●					
Allarme									
Impostazione le/Class non ammessa		gn	gn	gn	●				
Avvio bloccato, apparecchiatura troppo calda		ylw	●	●					
Errore									
Tensione di alimentazione dell'elettronica non ammessa		●	rd	●					
Impostazione le/Class non ammessa e IN (0 -> 1)		gn	rd						
Disinserzione protezione motore Relè di sovraccarico / termistore		gn	●						
Protezione motore a termistore Rottura del cavo / Cortocircuito		gn	●						
Sovraccarico termico apparecchiatura		ylw	rd	●					
- tensione di carico assente - Caduta di fase, carico mancante		gn	rd	●					
Guasto dell'apparecchio		rd	rd	●					
Funzione test									
1) Premere TEST t > 5 s		gn	●	rd	●				
RESET MODE (Premere per cambiare)									
Reset manuale					●				
Auto Reset					ylw				
Remote Reset vedi Figura 6.2					gn				

Indicazione dei LED							1) Test della disinserzione di protezione motore
				gn = verde	ylw = giallo	rd = rosso	



AVVERTENZA

Riavvio automatico.

Può causare morte, gravi danni alle persone o danni alle cose.

Il modo di reset automatico (RESET MODE) non dev'essere utilizzato in applicazioni nelle quali il riavvio inaspettato del motore dopo la scadenza del tempo di riattivazione può causare danni alle persone o alle cose.

Il comando di avvio (ad es. tramite il PLC) deve essere ripristinato prima di un comando di reset, dato che, in caso di comando d'avviamento imminente, dopo il comando di reset si verifica un ulteriore riavvio automatico. Ciò vale in particolar modo per lo sgancio di protezione motore. Per motivi di sicurezza si consiglia di includere l'uscita errore complessivo (morsetti 95 e 96) nel controllore.

Ler e compreender estas instruções antes da instalação, operação ou manutenção do equipamento.

	PERIGO	CUIDADO
	<p>Tensão perigosa. Perigo de morte ou ferimentos graves. Desligue a corrente antes de trabalhar no equipamento.</p>	<p>O funcionamento seguro do aparelho apenas pode ser garantido se forem utilizados componentes certificados.</p>

PERIGO

Tensão perigosa. Perigo de morte ou ferimentos graves.
Para evitar choque elétrico ou queimaduras, não podem ser tocados os bornes do aparelho de comando do motor quando este estiver sob tensão. Os bornes de saída também estão sob tensão quando o aparelho de comando do motor estiver desligado.

Distâncias na montagem individual (montagem junto a outros aparelhos, veja o manual do softstarter)

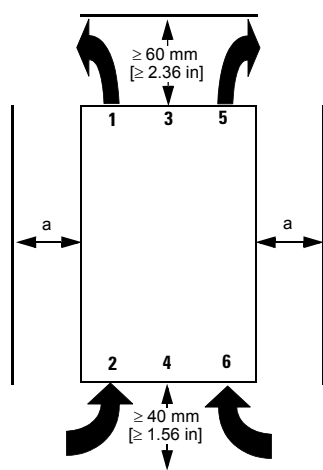

ATENÇÃO

Considere as distâncias indicadas na montagem do aparelho para que possa circular suficiente ar para a refrigeração. O aparelho é ventilado de baixo para cima.

CUIDADO

Risco de danos materiais.
Preste atenção de que não entre nenhum líquido, nenhuma poeira ou objeto condutivo dentro da chave de partida suave.

a) 3RW40 2: 15 mm [0.59 in]
3RW40 3; 3RW40 4: 30 mm [1.18 in]

Valores de ajuste da corrente do motor

Valores de ajuste da corrente do motor permitidos dependendo do ajuste da CLASS em temperatura ambiente de 40°C

	I_e [A]	I_{\min} [A]	I_{\max} [A] CLASS 10	I_{\max} [A] CLASS 15	I_{\max} [A] CLASS 20
3RW40 24-...	12,5	5	12,5	11	10
3RW40 26-...	25,3	10	25,3	23	21
3RW40 27-...	32,2	17	32,2	30	27
3RW40 28-...	38	23	38	34	31
3RW40 36-...	45	22,5	45	42	38
3RW40 37-...	63	25,5	63	50	46
3RW40 38-...	72	34,5	72	56	50
3RW40 46-...	80	42,5	80	70	64
3RW40 47-...	106	46	106	84	77

Programação da saída 13/14 ON/RUN (Ajuste feito na fábrica: ON) (parte do gráfico, figura 3)

- Iniciar a programação:** (retirar a tampa do equipamento 3RW40 2, conforme mostrado na figura 2.) Pressionar a tecla "RESET MODE" (2) por mais de 3 s, até que o LED "DEVICE" (5) cintile em verde. Manter a tecla "RESET MODE" (2) pressionada e, simultaneamente, pressionar a tecla "RESET/TEST" (2) por mais de 1 s, até que o LED "DEVICE" (5) acenda em vermelho no equipamento.
- Exibir o modo:** o LED "STATE/BYPASSED/FAILURE" (6) pisca em verde: modo ON. LED "STATE/BYPASSED/FAILURE" (6) cintila em verde: modo RUN.
- Mudar o modo:** pressionar a tecla "RESET MODE" (2).
- Finalizar a programação e salvar os ajustes:** pressionar a tecla "RESET/TEST" (1) por mais de 1 s, até que o LED "DEVICE" (5) acenda em verde.

Instrução para a colocação em serviço rápida

Conexão do termistor (somente 3RW40.-TB0.)

- Conexão termoclick conforme figura 6.3 (retirar fio de ponte)
- Conexão PTC tipo A conforme figura 6.4

CUIDADO
Risco de danos materiais!
 Não é permitida a conexão a bornes não ocupados.

Proposta de ajuste	Parâmetros de partida			Parâmetros de parada
	Tensão inicial %	Tempo de partida s	Valor limitador de corrente	Tempo de parada s
Aplicação				
Corrente transportadora	70	10	5 x I _e	5
Transportador de rolos	60	10	5 x I _e	5
Compressor	50	10	4 x I _e	0
Ventilador pequeno	40	10	4 x I _e	0
Bomba	40	10	4 x I _e	10
Bomba hidráulica	40	10	4 x I _e	0
Agitador	40	20	4 x I _e	0
Fresadora	40	20	4 x I _e	0

Colocação em serviço rápida
 3RW40 SIRIUS
 Softstarter

1. Controle da fiação
 - parte de comando e
 - parte de capacidade

2. Parametrizar o aparelho
Protetor do motor
 - ajustar a corrente medida do motor do acionamento no ajustador I_e
 - ajustar a classe de desligamento necessária no interruptor CLASS.
Função da chave de partida suave
 - Valor limitador de corrente (x I_e)
 - Tempo de partida (s)
 - Tensão inicial (%)
 - Tempo de parada (s)
 ajustar os valores desejados (veja a tabela Proposta de ajuste).

3. Verificar e conectar as tensões no circuito de corrente
 Apurar e eliminar a causa do erro através da indicação LED e tabela de estado. (veja Página 19)

LED "DEVICE" luz contínua verde, estão desligados os outros LEDs?

sim
 não

4. Ligar a chave de partida suave (IN 0 -> 1)

LEDs: "DEVICE" luz contínua verde, "STATE/BYPASSED" verde piscando?

sim
 não

Parte o motor suavemente?

sim
 não

Motor alcança rapidamente, sua velocidade de rotação nominal dentro do tempo desejado?

sim
 não

LEDs: "DEVICE" luz contínua verde, "STATE/BYPASSED" luz contínua verde?

sim
 não

Desligar a chave de partida suave (IN 1 -> 0)

sim

Qual foi o tipo de parada selecionado?

Parada livre
 Parada suave

Motor alcança a parada desejada?

sim
 não

Colocação em serviço finalizada

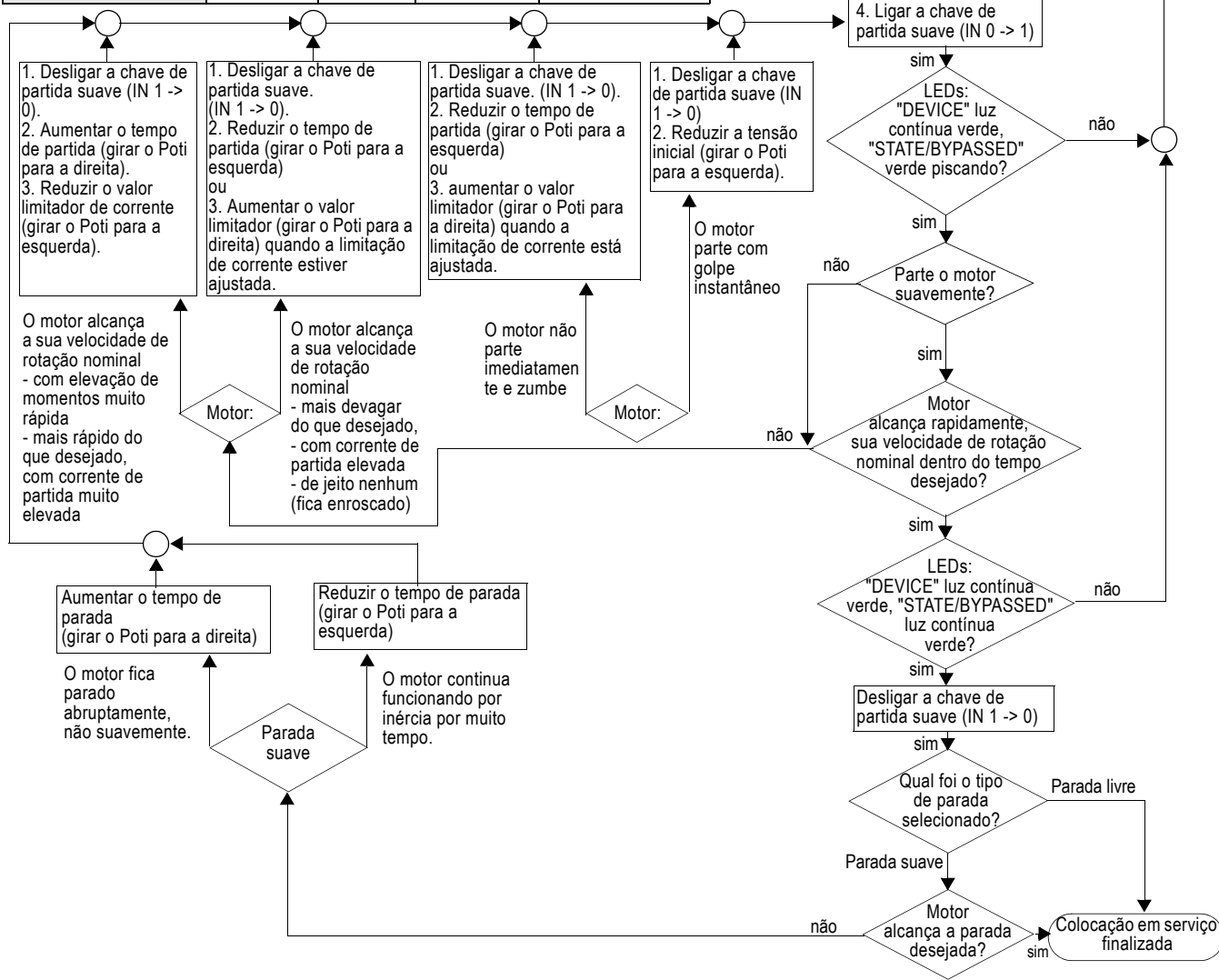

Português

Sinóptico de indicações

		Indicadores LED 3RW40				Contatos auxiliares			
		Chave de partida suave		Proteção do motor					
3RW40		DEVICE (rd/gn/ylw)	STATE / BYPASSED / FAILURE (gn/rd))	OVERLOAD (rd)	RESET MODE (ylw/gn)	13 14 (ON)	13 14 (RUN)	24 23 (BYPASSED)	96 95 98 FAILURE / OVERLOAD
U _s = 0		●	●	●	●				
Estado operativo	IN								
Desligado	0	gn	●	●					
Partida	1	gn	gn	●					
Bypassed	1	gn	gn	●					
Marcha por inércia	0	gn	gn	●					
Advertência									
Ajuste Ie/class não permissível		gn	gn						
Partida bloqueada, equip. muito quente		ylw	●	●					
Erro									
Tensão de alimentação do sistema eletrônico não permissível		●	rd	●					
Ajuste Ie/Class não permissível e IN (0 -> 1)		gn	rd						
Desativação de proteção do motor Relé de sobrecarga / termistor		gn	●						
Proteção do motor termistor Ruptura do fio / curto circuito		gn	●						
Sobrecarga térmica do equipamento		ylw	rd	●					
- falta tensão de carga - Falta de fase, falta de carga		gn	rd	●					
Erro de equipamento		rd	rd	●					
Função de teste									
1) Pressionar TEST t > 5 s		gn	●	rd	●				
RESET MODE (pressionar para trocar)									
Reset manual					●				
Reset automático					ylw				
Remote Reset veja figura 6.2					gn				
Indicação dos LEDs									
				gn =	ylw =	rd =	1) Teste da desativação de proteção do motor		
Desligado	Ligado	Piscante	Cintilante	verde	amarelo	vermelho			

⚠ ADVERTÊNCIA





Repartida automática

Pode causar a morte, danos pessoais ou materiais graves.

A modalidade de reinicialização automática (RESET MODE) não pode ser utilizada em aplicações onde a reinicialização inesperada do motor, depois de expirado o tempo de prontidão, possa causar danos pessoais ou materiais.

O comando de iniciação (p. ex. através do SPS) deve ser reinicializado antes de um comando de reset, já que é efetuada uma reinicialização independente automaticamente quando estiver a ser efetuado o comando de iniciação depois do comando de reset. Isto vale principalmente para a ativação da proteção do motor. Por motivos de segurança é sugerido que a saída de erros coletivos (bornes 95 e 96) seja integrado no comando.

Cihazın kurulumundan, çalıştırılmasından veya bakıma tabi tutulmasından önce, bu kılavuz okunmuş ve anlaşılmış olmalıdır.

 	TEHLİKE	ÖNEMLİ DİKKAT
<p>Tehlikeli gerilim. Ölüm tehlikesi veya ağır yaralanma tehlikesi. Çalışmalara başlamadan önce, sistemin ve cihazın gerilim beslemesini kapatınız.</p>		<p>Cihazın güvenli çalışması ancak sertifikalı bileşenler kullanılması halinde garanti edilebilir.</p>

TEHLİKE
<p>Tehlikeli gerilim. Hayati tehlike veya ağır yaralanma tehlikesi. Cihaz gerilim beslemesi altında iken, elektrik çarpmasından veya yanıklardan sakınmak için, motor kontrol cihazının kısıkaçlarıyla temas edilmemelidir. Motor kontrol cihazı KAPALI halde iken de çıkış kısıkaçlarında gerilim mevcuttur.</p>

Tek tek kurulumda montaj mesafeleri (Sıkı kurulum bkz. Yumuşak yol verici kullanım kılavuzu)

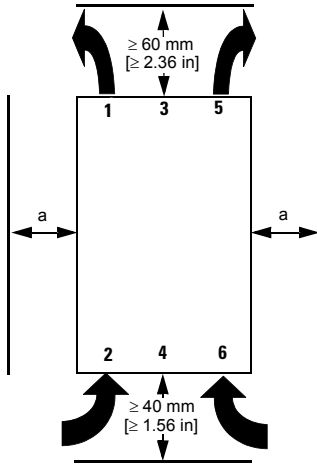

a) 3RW40 2: 15 mm [0.59 in]
 3RW40 3; 3RW40 4: 30 mm [1.18 in]

DİKKAT

Soğutma için yeterli derecede hava sirkülasyonunun sağlanması amacıyla cihazı monte ederken belirtilen mesafelere riayet ediniz. Cihaz, aşağıdan yukarıya doğru havalandırılmaktadır.

ÖNEMLİ DİKKAT

Maddi hasar tehlikesi.

Yumuşak yol vericiye sıvı, toz veya herhangi bir cisim kaçmamasına dikkat ediniz.

Motor akımı ayar değerleri

CLASS ayarına bağlı olarak izin verilen motor akımı ayar değerleri 40° C ortam ısısında

	I_e [A]	I_{asg} [A]	I_{azm} [A] CLASS 10	I_{azm} [A] CLASS 15	I_{azm} [A] CLASS 20
3RW40 24-...	12,5	5	12,5	11	10
3RW40 26-...	25,3	10	25,3	23	21
3RW40 27-...	32,2	17	32,2	30	27
3RW40 28-...	38	23	38	34	31
3RW40 36-...	45	22,5	45	42	38
3RW40 37-...	63	25,5	63	50	46
3RW40 38-...	72	34,5	72	56	50
3RW40 46-...	80	42,5	80	70	64
3RW40 47-...	106	46	106	84	77

13/14 ON/RUN çıkışının programlanması (Fabrika ayarı: ON) (Grafik bölümü, Resim 3)

- Programlamayı başlatınız:** (3RW40 2 cihazında kapağı Resim 2'de gösterildiği şekilde çıkarınız.) "RESET MODE" (2) tuşuna LED "DEVICE" (5) yeşil renkte titrek yanana kadar 2 saniyeden uzun süre basınız. "RESET MODE" (2) tuşunu basılı tutunuz ve aynı zamanda cihazdaki LED "DEVICE" (5) kırmızı yanana kadar "RESET/TEST" (1) tuşuna 1 saniyeden daha uzun süreyle basınız.
- Modun gösterilmesi:** LED "STATE/BYPASSED/FAILURE" (6) yeşil yanıp söner: ON Modu. LED "STATE/BYPASSED/FAILURE" (6) yeşil renkte titrek yanar: RUN Modu.
- Modun değiştirilmesi:** "RESET MODE" (2) tuşuna basınız.
- Programlamanın bitirilmesi ve ayarların hafızaya alınması:** "RESET/TEST" (1) tuşuna LED "DEVICE" (5) yeşil yanana kadar 1 saniyeden uzun süre basınız.

Hızlıca ilk çalıştırma talimatı

Termistör bağlantısı (sadece 3RW40.-TB0.)

- Resim 6.3'e göre Thermoclick bağlantısı (geçici olarak kullanılan bağlantı telini çıkarınız)
- Resim 6.4'e göre PTC Tip A bağlantısı



ÖNEMLİ DİKKAT

Maddi hasar tehlikesi!
Boştaki kısaçklara bağlantı yasaktır.

Ayar önerisi	Yol verme (Start) parametresi			Durma parametresi
	Start gerilimi %	Yol verme süresi sn	Akım tahdit değeri	
İşlem	Start gerilimi % 	Yol verme süresi sn 	Akım tahdit değeri 	Durma süresi sn
Sevk şeridi	70	10	5 x I _e	5
Döner sevk tertibatı	60	10	5 x I _e	5
Kompresör	50	10	4 x I _e	0
Küçük vantilatör	40	10	4 x I _e	0
Pompa	40	10	4 x I _e	10
Hidrolik pompa	40	10	4 x I _e	0
Karıştırma tertibatı	40	20	4 x I _e	0
Freze makinesi	40	20	4 x I _e	0

Hızlıca ilk çalıştırma
3RW40 SİRİUS
Yumuşak yol verici

1. Kablolama kontrolü
- Kumanda bölümü ve
- Performans bölümü

2. Cihazı parametreleyiniz
Motor koruma
- I_e ayarlayıcısında tahrik mekanizmasının motor ölçüm akımını ayarlayınız
- CLASS şalterinde gerekli devre kapama sınıfını ayarlayınız.
Yumuşak yol verme fonksiyonu
- Akım tahdit değeri (x I_e)
- Yol verme süresi (sn)
- Start gerilimi (%)
- Durma süresi (sn)
İstenen değerlere ayarlayınız (Bkz. Tablo, Ayar önerisi).

3. Denetim devresinde ve ana devredeki gerilimleri kontrol ediniz ve devreye sokunuz.
LED göstergesi ve pozisyon tablosu üzerinden ayrıca nedenini bulunuz ve bertaraf ediniz. (Bkz. Sayfa 22)

"DEVICE" LED göstergesi devamlı yeşil yanıyor, diğer LED göstergeleri kapalı mı?

Hayır

Evet

4. Yumuşak yol vericiyi açınız (IN 0 -> 1)

Evet

LED göstergeleri: "DEVICE" devamlı yeşil yanıyor, "STATE/BYPASSED" yeşil yanıp sönüyor mu?

Evet

Motor yumuşak biçimde yol aldı mı?

Evet

Motor hızla, istenen süre içinde nominal devir sayısına ulaşıyor mu?

Evet

LED göstergeleri: "DEVICE" devamlı yeşil yanıyor, "STATE/BYPASSED" devamlı yeşil yanıyor mu?

Evet

Yumuşak yol vericiyi kapatınız (IN 1 -> 0).

Evet

Hangi yol verme türü seçildi?

Evet

Motor istendiği şekilde duruyor mu?

Evet

Serbest duruş

Hayır

Yumuşak duruş verme

Hayır

Evet

Çalıştırma tamamlandı

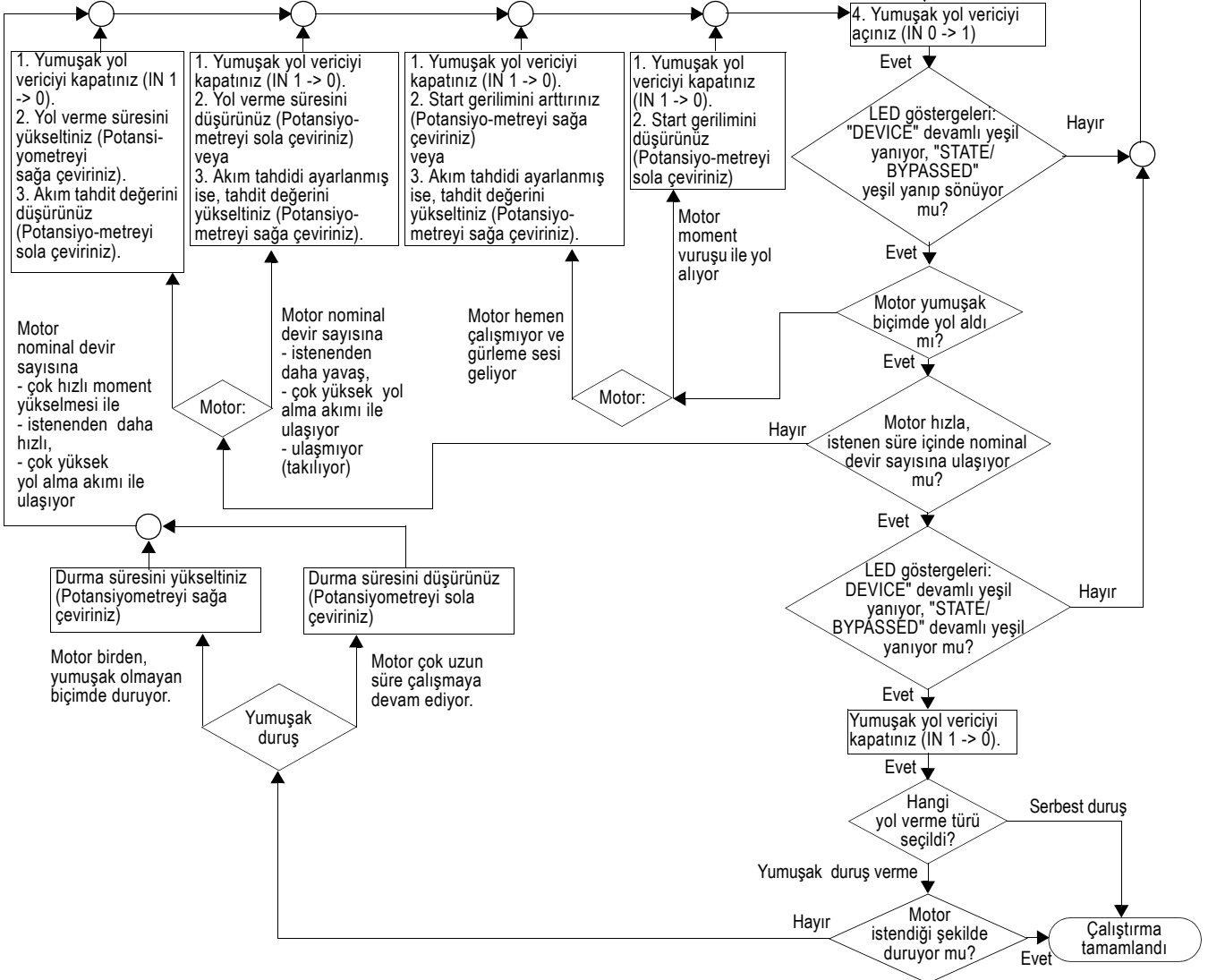

Gösterge tablosu

		LED göstergeleri 3RW40				Yardımcı kontaklar			
		Yumuşak yol verici		Motor koruma					
3RW40		DEVICE (rd/gn/ylw)	STATE / BYPASSED / FAILURE (gn/rd)	OVERLOAD (rd)	RESET MODE (ylw/gn)	13 14 (ON)	13 14 (RUN)	24 23 (BYPASSED)	96 95 98 FAILURE / OVERLOAD
$U_s = 0$		●	●	●	●				
İşletme durumu	IN								
Kapalı	0		●	●					
Yol verme	1			●					
Bypassed	1			●					
Durma	0			●					
Uyarı									
le/Class ayarı kabul edilmiyor									
Start bloke edildi, cihaz çok sıcak			●	●					
Arıza									
Tedarik gerilimi Elektronik kabul edilmiyor		●		●					
Kabul edilmeyen le/Class ayarı ve IN (0 -> 1)									
Motor koruma kapaması Aşırı yük rölesi / Termistör			●						
Termistör motor koruması Tel kırılması / Kısa devre			●						
Cihazda termik aşırı yük				●					
- Yük gerilimi yok - Faz kesilmesi, eksik yük				●					
Cihaz hatası				●					
Test fonksiyonu									
1) TEST t > 5 sn basınız			●		●				
RESET MODE (Değiştirmek için basılır)									
Manüel reset					●				
Otomatik reset									
Uzaktan reset Resim 6.2									

LED göstergeleri				gn	ylw	rd	1) Test Motor koruma kapaması
				=	=	=	
kapalı	açık	yanıp söner	titrer	yeşil	sarı	kırmızı	

⚠ UYARI



Otomatik olarak yeniden çalışma.

Ölüme, ağır yaralanmalara veya maddi hasara yol açabilir.

Otomatik sıfırlama modu (RESET MODE), motorun yeniden işleme hazır duruma gelme süresinin bitiminden sonra beklenmedik biçimde yeniden start almasının, yaralanma ya da maddi hasara yol açabileceği durumlarda kullanılamaz.

Start komutu (örn. SPS ile) reset komutundan önce verilmelidir, çünkü reset komutundan sonra verilecek bir start komutunda otomatik olarak yeniden ve kendiliğinden bir start alma durumu ortaya çıkar. Bu özellikle de motor koruma tertibatının saliverilmesi için geçerlidir. Emniyet nedeniyle toplu hata çıkışının (95 ve 96 kısaçları) kumandaya bağlanması tavsiye edilir.

Перед установкой, вводом в эксплуатацию или обслуживанием устройства необходимо прочесть и понять данное руководство.

ОПАСНО

Опасное напряжение. Опасность для жизни или возможность тяжелых травм.
Перед началом работ отключить подачу питания к установке и к устройству.

ОСТОРОЖНО

Безопасность работы устройства гарантировано только при использовании сертифицированных компонентов.

ОПАСНО

Опасное напряжение. Опасность для жизни или опасность получения тяжелых травм.
Во избежание получения электрического удара или сильного ожога нельзя прикасаться к клеммам устройства управления двигателем, когда прибор находится под напряжением. На выходных клеммах имеется напряжение, даже если устройство управления двигателем находится в выключенном состоянии.

Расстояния при встраивании (расположение плотно друг к другу см. в руководстве пользователя к прибору для плавного запуска)

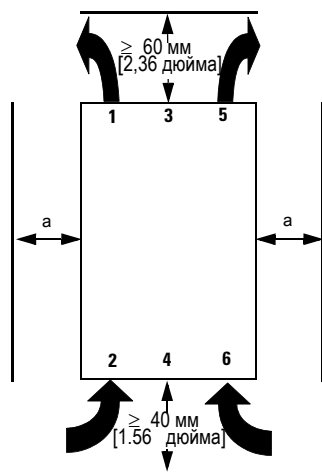

а) 3RW40 2: 15 мм [0,59 дюйма]
3RW40 3; 3RW40 4: 30 мм [1,18 дюйма]

ВНИМАНИЕ

Учтите при встраивании прибора указанные расстояния, чтобы для его охлаждения было достаточно циркулирующего воздуха. Прибор вентилируется снизу вверх.

ОСТОРОЖНО

Опасность повреждения материальных ценностей.
Следите за тем, чтобы в прибор для плавного запуска двигателей не попадали жидкость, пыль или проводящие предметы.

Настроечные значения токов двигателя

Допустимые настроечные значения токов двигателя в зависимости от настройки КЛАССА (CLASS) при температуре окружающей среды 40° С

	I_e [A]	$I_{мин}$ [A]	$I_{макс}$ [A] CLASS 10	$I_{макс}$ [A] CLASS 15	$I_{макс}$ [A] CLASS 20
3RW40 24-...	12,5	5	12,5	11	10
3RW40 26-...	25,3	10	25,3	23	21
3RW40 27-...	32,2	17	32,2	30	27
3RW40 28-...	38	23	38	34	31
3RW40 36-...	45	22,5	45	42	38
3RW40 37-...	63	25,5	63	50	46
3RW40 38-...	72	34,5	72	56	50
3RW40 46-...	80	42,5	80	70	64
3RW40 47-...	106	46	106	84	77

Программирование выхода ON/RUN, клеммы 13/14 (заводская настройка: ON) (графическая часть, рис. 3)

- Начать программирование:** (В приборе 3RW40 2 следует снять крышку, как это показано на рис. 2.) Держите кнопку "RESET MODE" ("СБРОС РЕЖИМА") (2) нажатой дольше 2 секунд до тех пор, пока светодиод "DEVICE" ("ПРИБОР") (5) не начнет мерцать зеленым светом. Держите кнопку "RESET MODE" (2) нажатой и одновременно нажмите кнопку "RESET/TEST" ("СБРОС/ТЕСТ") (1) дольше 1 с, пока светодиод "DEVICE" (5) на приборе не начнет светиться красным светом.
- Показать режим:** Светодиод "STATE BYPASSED/FAILURE" (6) мигает зеленым светом: Режим ON. Светодиод "STATE BYPASSED/FAILURE" ("СОСТОЯНИЕ БАЙПАС/ОТКАЗ") (6) мигает зеленым светом: Режим RUN (РАБОТА).
- Поменять режим:** Нажать кнопку "RESET MODE" ("СБРОС РЕЖИМА") (2)
- Завершить программирование и сохранить настройки:** Держите кнопку "RESET/TEST" ("СБРОС/ТЕСТ") (1) дольше 1 с до тех пор, пока светодиод "DEVICE" ("ПРИБОР") (5) не начнет мерцать зеленым светом.

Руководство для быстрого запуска в эксплуатацию

Подключение термистора (только для 3RW40.-TB0.)

- Подключение термоконтакта в соответствии с рис. 6.3 (необходимо удалить проводящую перемычку)
- Подключение термистора РТС (с положительным термокоэффициентом) типа А в соответствии с рис. 6.4

Предложение по настройке	Параметры запуска			Параметры постепенной остановки
	Стартовое напряжение %	Время запуска, с	Ограничение тока	Время постепенной остановки, с
Применение				
Ленточный конвейер	70	10	5 x I _e	5
Роликовый транспортер	60	10	5 x I _e	5
Компрессор	50	10	4 x I _e	0
Небольшой вентилятор	40	10	4 x I _e	0
Насос	40	10	4 x I _e	10
Гидравлический насос	40	10	4 x I _e	0
Мешалка	40	20	4 x I _e	0
Фрезерный станок	40	20	4 x I _e	0

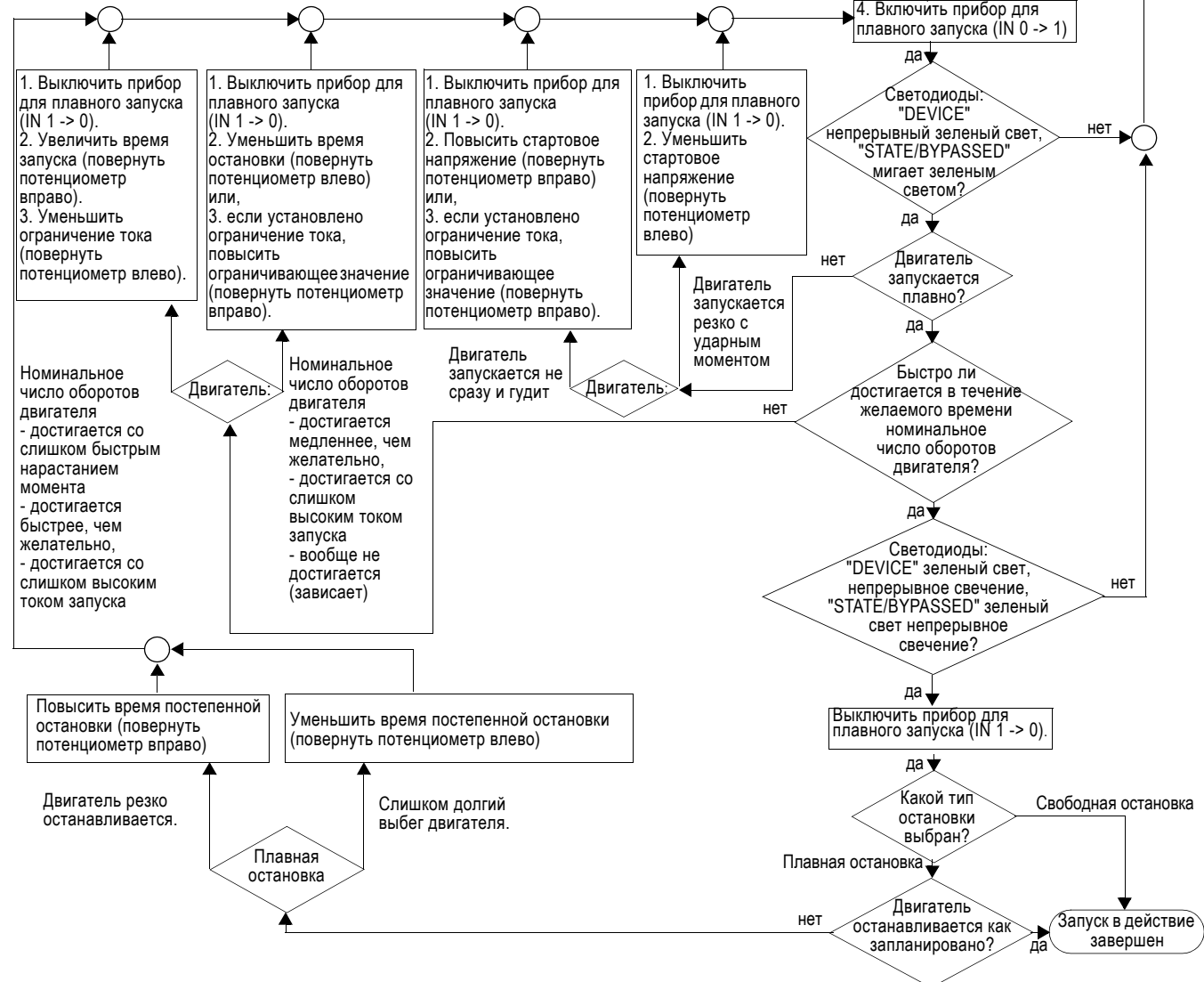

Русский

Обзор индикаторов

		Светодиодная индикация 3RW40				Вспомогательные контакты			
		Прибор для плавного запуска двигателей		Моторная защита					
3RW40		DEVICE (rd/gn/ ylw)	STATE / BYPASSED / FAILURE (gn/rd))	OVERLOAD (rd)	RESET MODE (ylw/gn)	13 14 (ON)	13 14 (RUN)	24 23 (BYPASSED)	96 95 98 FAILURE / OVERLOAD
$U_s = 0$		●	●	●	●				
Рабочее состояние	IN								
Выкл	0		●	●					
Запуск	1			●					
Bypassed	1			●					
Постепенная остановка	0			●					
Предупреждение									
Настройка Ie/Class недопустима									
Пуск заблокирован, прибор слишком горячий			●	●					
Неисправность									
Недопустимое напряжение питания электроники		●		●					
Недопустимая настройка Ie/Class и IN (0 -> 1)									
Выключение со стороны моторной защиты Реле перегрузки / термистор			●						
Термисторная моторная защита Обрыв кабеля / короткое замыкание			●						
Прибор - термическая перегрузка				●					
- отсутствие напряжения нагрузки - пропадание фазного напряжения, отсутствует нагрузка				●					
Неисправность прибора				●					
Тестовая функция									
1) TEST t > 5 с (нажать эту кнопку)			●		●				
RESET MODE (нажать для смены режима)									
Ручной сброс					●				
Автоматический сброс									
Дистанционный сброс см. рис. 6.2									

Показания светодиодов							1) Тест отключения со стороны моторной защиты
				gn =	ylw =	rd =	
выкл	вкл	мигающий	мерцающий	зеленый	желтый	красный	

⚠ ПРЕДУПРЕЖДЕНИЕ



Автоматический повторный запуск.

Может привести к смертельному исходу, тяжелым травмам или материальному ущербу.

Автоматический режим сброса (RESET MODE) нельзя использовать в тех случаях, когда неожиданный повторный запуск двигателя по истечении нового времени готовности может привести к человеческим жертвам или повреждениям материальных ценностей.

Команда старта (напр., от микроконтроллера) должна быть сброшена командой сброса, т.к. при наличии команды старта после действия команды сброса автоматически происходит самостоятельный повторный запуск. Это особенно характерно для случаев срабатывания моторной защиты. По соображениям безопасности рекомендуется опрашивать и использовать в системе управления выход общей неисправности (клеммы 95 и 96).

安装前，一定要仔细阅读并理解此规程，以便正确操作和维护此设备。

⚠ 危险

危险电压
致命或重伤危险。
工作开始前关掉设备与机器的电压。

注意

一个安全的设备运作只有在使用所许可的元件的情况下才能得以保证！

危险

危险电压。致命或重伤危险。
为了避免受到电击或烧伤，机器有电压时，不去触摸电机控制器的接线端。电机控制器在关机状态时，输出接线端处也有电压。

单个启动器的安装间距（多个启动器安装布局参见软启动器手册）

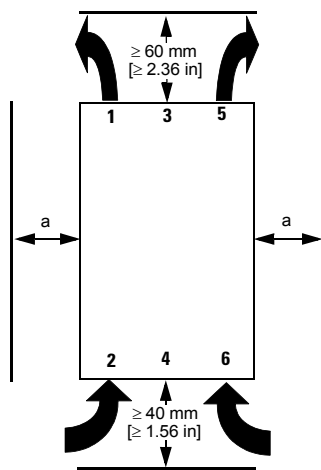

注意

在安装此机器时，一定要注意规定的间距，以此保证足够的冷却空气流通。此机器是从下往上通风的。

注意

设备损坏危险。
一定要注意不要有液体、灰尘或导电物体进入软启动器里面。

a) 3RW40 2: 15 mm [0.59 in]
3RW40 3; 3RW40 4: 30 mm [1.18 in]

电机电源设定值

取决于 CLASS- 设定调整的额定电机电源设定值 在环境温度为摄氏 40° 明

	I_e [A]	I_{min} [A]	I_{max} [A] CLASS 10	I_{max} [A] CLASS 15	I_{max} [A] CLASS 20
3RW40 24-...	12,5	5	12,5	11	10
3RW40 26-...	25,3	10	25,3	23	21
3RW40 27-...	32,2	17	32,2	30	27
3RW40 28-...	38	23	38	34	31
3RW40 36-...	45	22,5	45	42	38
3RW40 37-...	63	25,5	63	50	46
3RW40 38-...	72	34,5	72	56	50
3RW40 46-...	80	42,5	80	70	64
3RW40 47-...	106	46	106	84	77

ON/RUN 输出端连接 13/14 的编程（工厂设置：ON）（图表部分，图 3）

1. **开始编程序序：**（如图 2 所示去掉设备 3RW40 2 的盖板。）按住按键 "RESET MODE" (2) 2 秒钟以上，直到 LED "DEVICE" (5) 显示灯闪绿色。按住按键 "RESET MODE" (2) 不放 并按住按键 "RESET/TEST" (1) 1 秒钟以上，直到 LED "DEVICE" (5) 闪红色。
2. **模式显示：** LED "STATE/BYPASSED/FAILURE" (6) 闪绿色： ON 模式 LED "STATE/BYPASSED/FAILURE" (6) 闪绿色： RUN 模式
3. **更换模式：** 操作按键 "RESET MODE" (2)。
4. **结束编程，存储设置：** 按住按键 "RESET/TEST" (1) 1 秒钟以上，直到 LED "DEVICE" (5) 显绿色。

快捷式首次启用规程

热敏电阻连接（只用于 3RW40.-TB0.）

- 根据图表 6.3 连接 ThermoClick（去掉线桥）。
- 根据图表 6.4 连接 PTC 型号 A。

注意
物品损坏危险!
不允许连接到用不上的接线端上。

参考设定	启动参数			减速停止参数
使用目的	启动电压 %	启动时间 s	电源界限值	减速停止时间 s
传送带	70	10	$5 \times I_e$	5
滚子传送带	60	10	$5 \times I_e$	5
压缩机	50	10	$4 \times I_e$	0
小风扇	40	10	$4 \times I_e$	0
泵	40	10	$4 \times I_e$	10
液压泵	40	10	$4 \times I_e$	0
搅动装置	40	20	$4 \times I_e$	0
铣床	40	20	$4 \times I_e$	0

快捷式首次启动
3RW40 SIRIUS
软启动器

1. 布线检查
- 控制部分与
- 功能部分

2. 给设备设定参数
电机保护
- 用 I_e - 额定电流设置器来设定驱动电机所用的限定电源
- 用 CLASS- 开关设定必要的断路级别。
软启动功能
- 电源界限限制 ($\times I_e$)
- 启动时间 (s)
- 启动电压 (%)
- 减速停止时间 (s)
设定所需值 (参见参考设置表)

3. 检查并打开控制与主电源循环的电压。
通过 LED- 液晶显示器和状态表来查找故障原因并排除故障。(见 28 页)

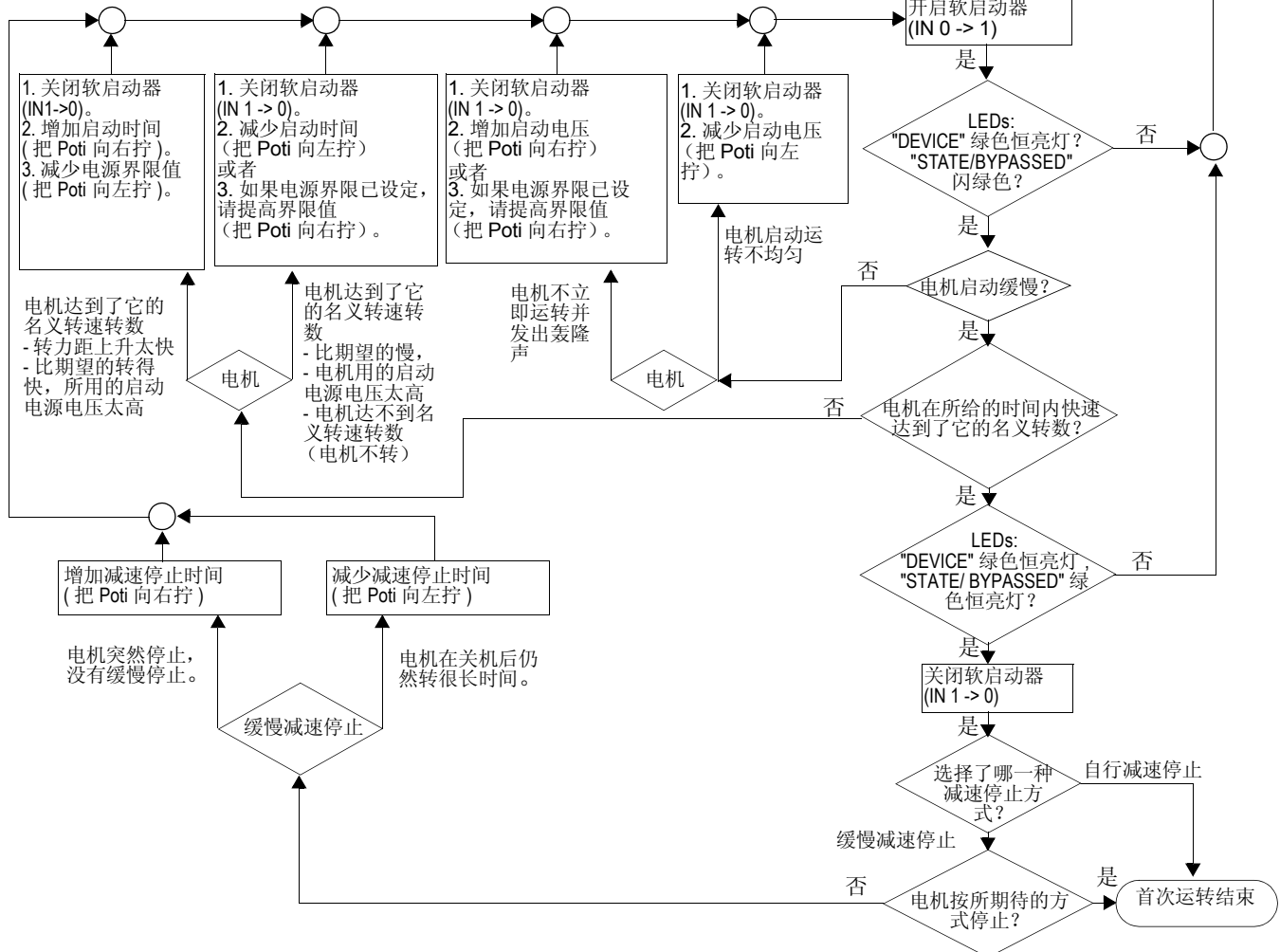

显示器及按钮一览

		LED- 显示 3RW40				辅助连接			
		软启动器		电机保护					
3RW40		DEVICE (rd/gn/ylw)	STATE / BYPASSED / FAILURE (gn/rd))	OVERLOAD (rd)	RESET MODE (ylw/gn)	13 14 (ON)	13 14 (RUN)	24 23 (BYPASSED)	96 95 98 FAILURE / OVERLOAD
U _s = 0		●	●	●	●				
运转状态	开								
关	0		●	●					
启动	1			●					
旁通	1			●					
减速停止	0			●					
警告									
禁止使用 le/Class- 设置									
启动被终止，设备太热			●	●					
故障									
电子部件禁止用供电电压		●		●					
不允许用的 le/Class- 设置和 IN (0 -> 1)									
电极保护断电 过负荷继电器 / 过敏电阻			●						
过敏电阻电机保护 电线破损 / 短路			●						
热超负荷设备				●					
- 缺少的负载电压 - 缺相, 缺负荷				●					
设备故障				●					
测试功能									
1) 按 TEST 键 5 秒以上			●		●				
RESET MODE (按此键转换)									
手动重设					●				
自动重设									
Remote Reset 见图 6.2									

LED 灯显示				gn	ylw	rd	1) Test 电机保护断路
				=	=	=	
关	开	闪烁	快速闪烁	绿色	黄色	红色	

警告



自动重新启动

会导致人员死亡、重伤或物品损坏。

如果在重新待命准备时间过后，电机出人意料的自行重新启动会导致人员伤亡或物品损坏时，千万不能使用自动复位模块 (RESET MODE) 的功能。

启动命令必须在给重设命令之前调回去（比如通过 SPS），因为在复位命令之后等待启动命令时，设备会进行再次自行启动。电机保护脱钩尤其是这样。出于安全考虑，建议把总故障输出端（接线端 95 和 96）接到控制上去。

1.

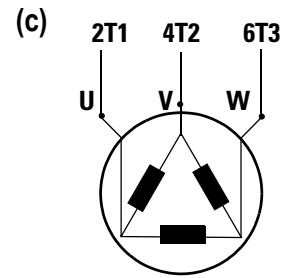
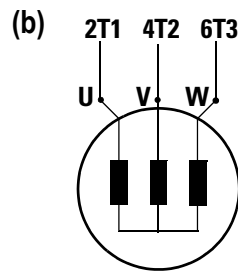
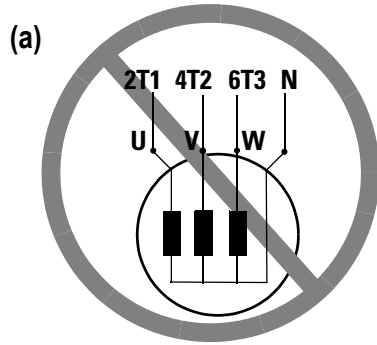

2.

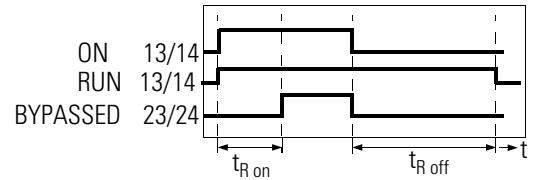
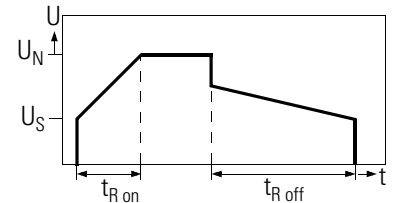
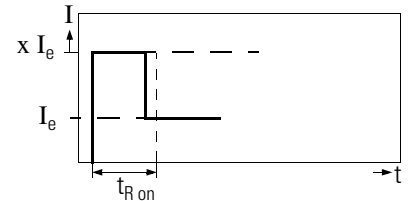
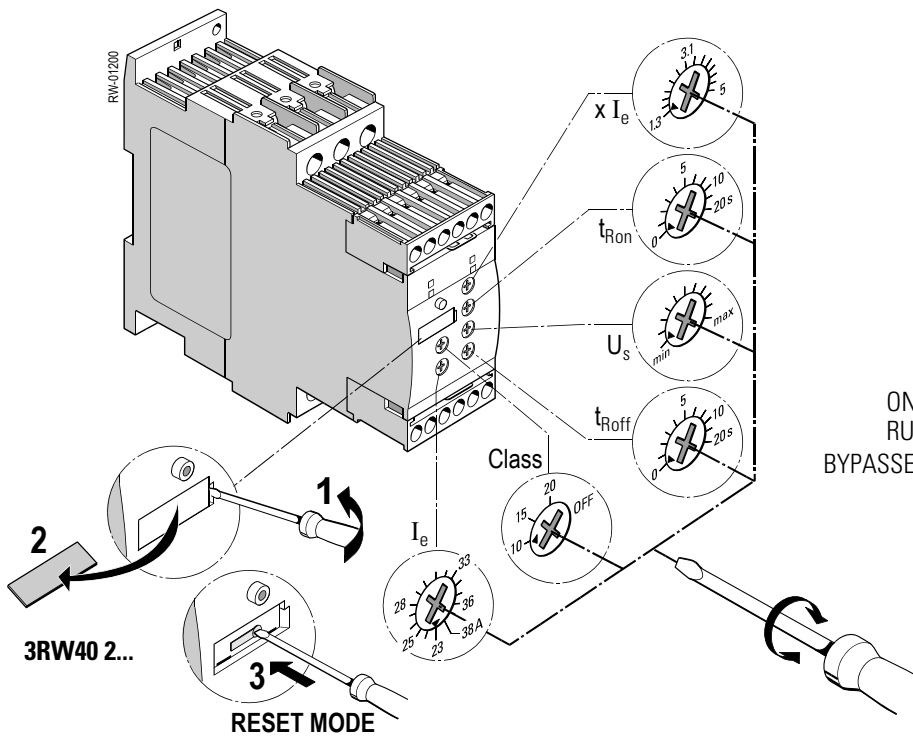

3.

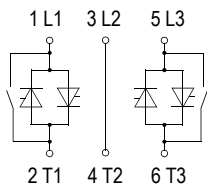

U_s: 3RW40...-B0.: ≈ 24 V ± 20 %
 3RW40...-B1.: ≈ 110...230 V -15 %, +10 %

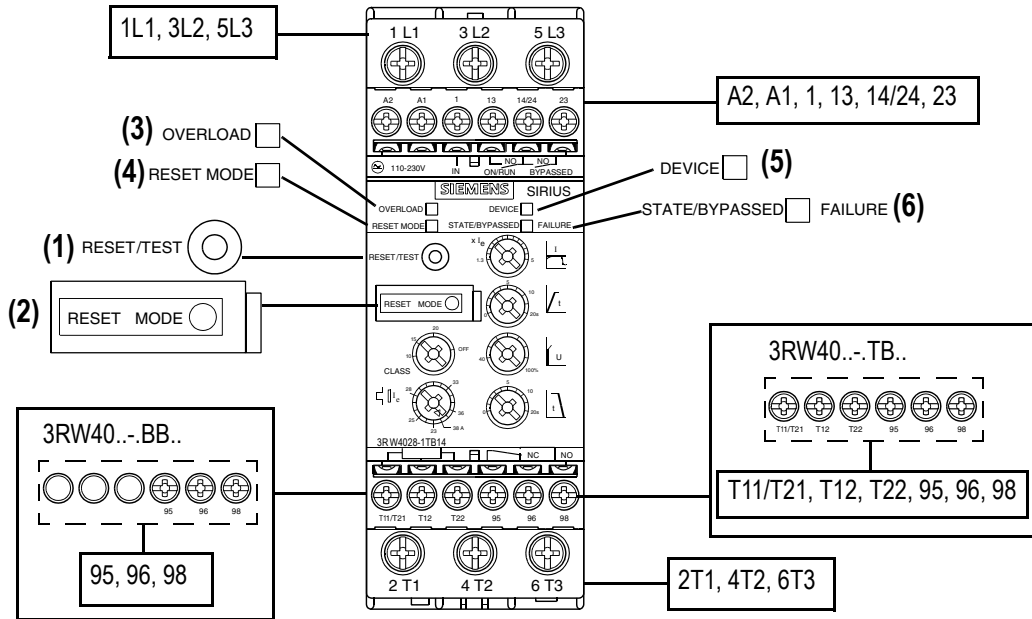

4.

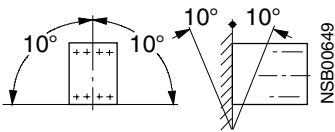

5.

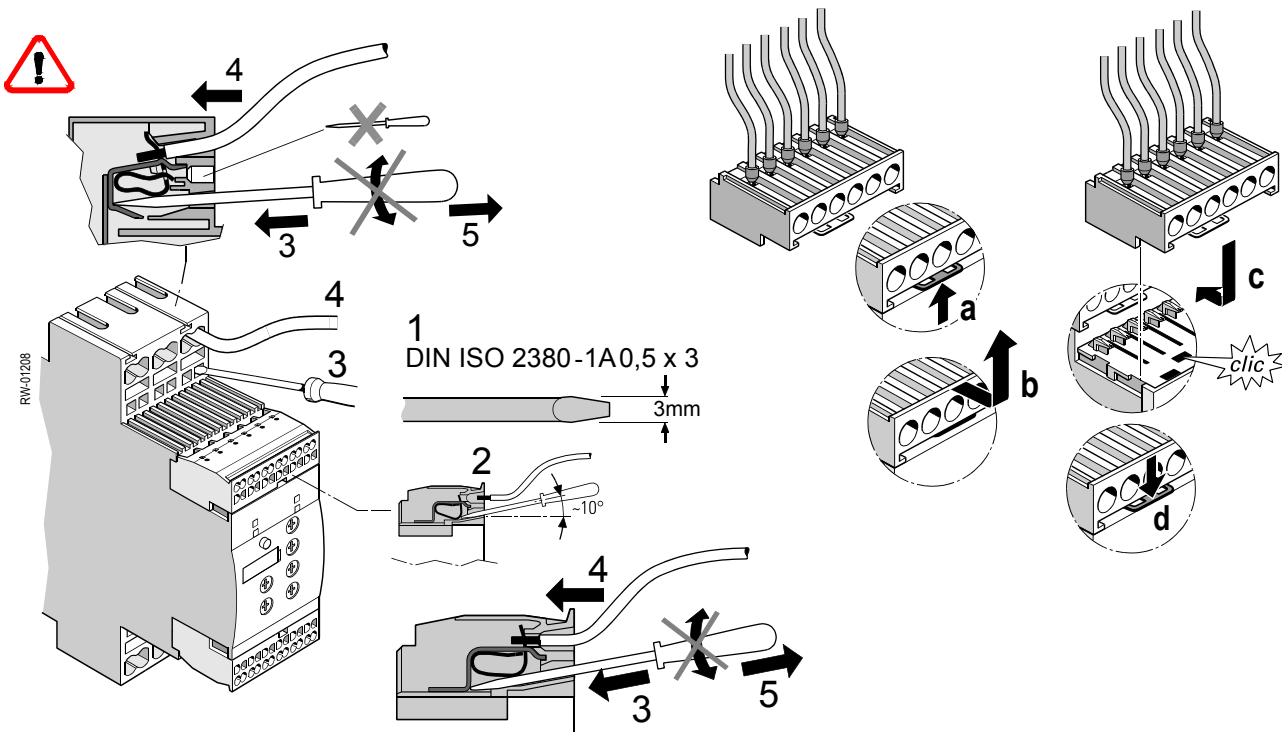

6.

6.1

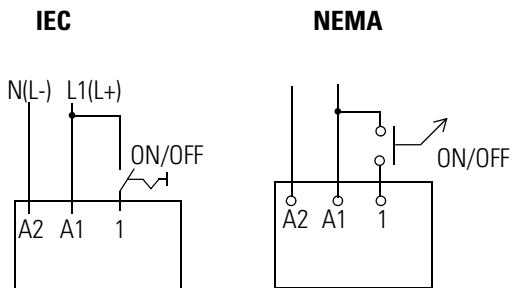

6.2

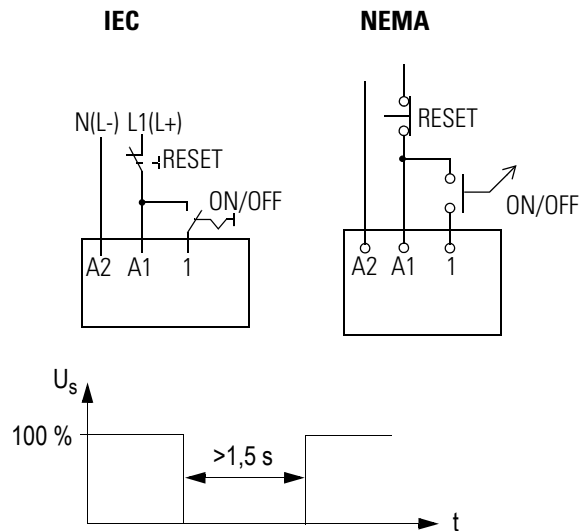

6.3

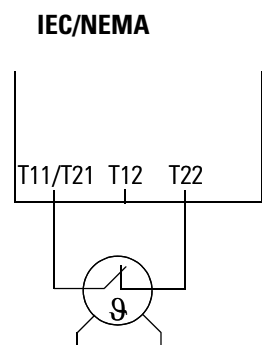

6.4

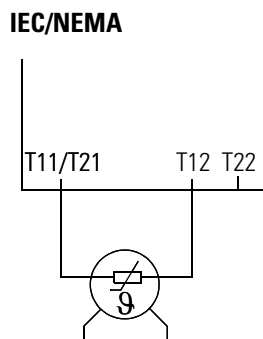

6.5

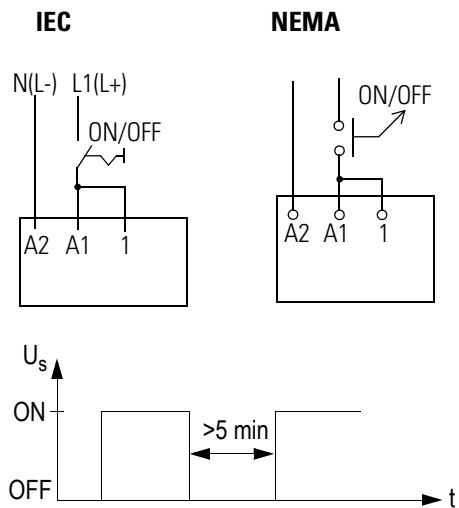

6.6

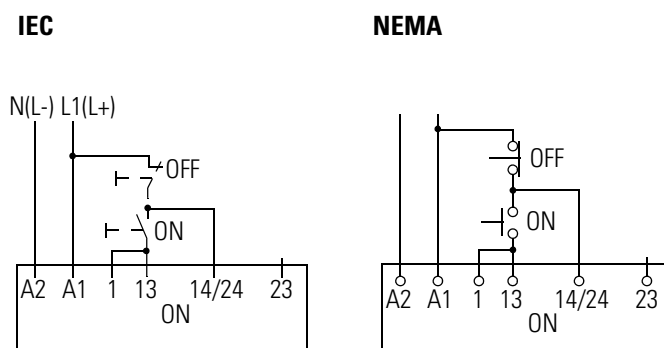

7.

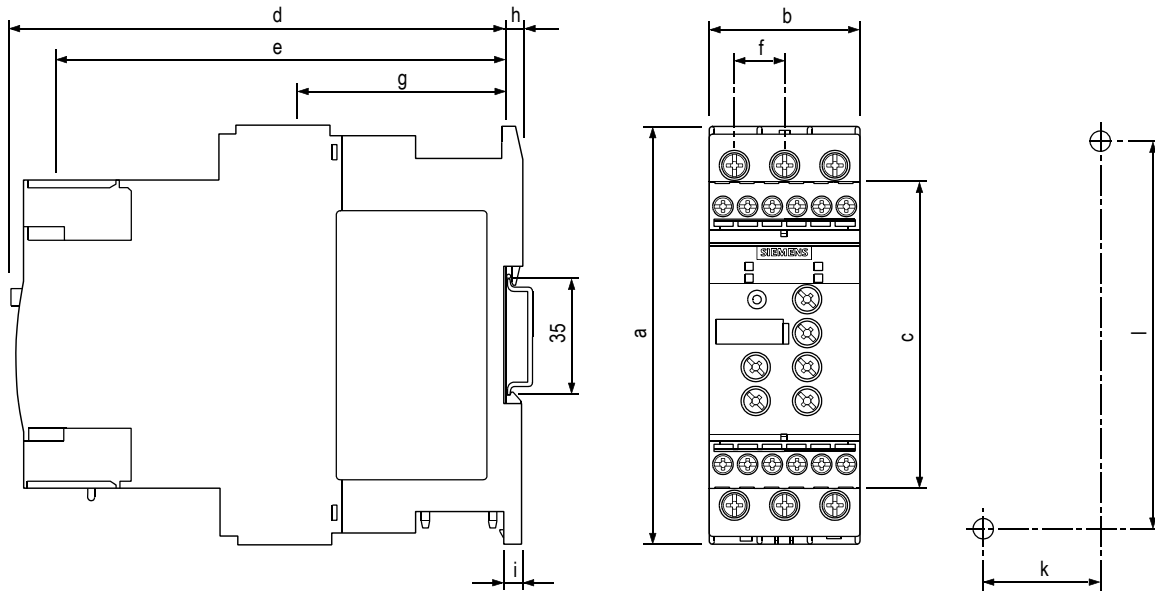

	a	b	c	d	e	f	g	h	i	k	l
3RW40 2	125 (4.92)	45 (1.8)	92 (3.62)	149 (5.90)	126 (5.00)	14,4 (0.57)	63 (2.48)	5 (0.2)	6,5 (0.26)	35 (1.38)	115 (4.53)
3RW40 3	160 (6.3)	55 (2.18)	110 (4.33)	165 (6.49)	140 (5.51)	18 (0.71)	63 (2.48)	5 (0.2)	6,5 (0.26)	30 (1.18)	150 (5.91)
3RW40 4	170 (6.7)	70 (2.76)	110 (4.33)	183 (7.20)	158 (6.22)	22,5 (0.89)	85 (3.35)	5 (0.2)	10 (0.4)	60 (2.36)	160 (6.3)

mm (inch)