

Manual Starters and Switches Selection Guide

Class 2510, 2511, 2512, 2601



CONTENTS

Description	Page
Class 2510, 2512 Type F Fractional Horsepower Manual Starters	3
Class 2510, 2511, 2512 Type K Manual Switches	6
Dimensions for Open Type	8
Dimensions for Types F and K	9
Class 2510, 2511, 2512 Integral Horsepower Starters – Types M and T	13
Dimensions for Types M and T	15
Accessories and Modifications	19
Class 2601 Reversing Drum Switches	20
Dimensions for Reversing Drum Switches	21



SQUARE D
GROUPE SCHNEIDER





Type FG2P

**FRACTIONAL HORSEPOWER MANUAL STARTERS
WITH MELTING ALLOY TYPE THERMAL OVERLOAD RELAY**

Application Data

Type F fractional horsepower starters provide overload protection as well as manual “On-Off” control for small motors in a variety of industrial and commercial installations. Typical applications include fans, conveyors, pumps, and small machine tools.

They are available in one or two pole versions. Both one-pole and two-pole versions are suitable for use with AC single phase motors rated up to 1 horsepower. Two-pole starters may also be used with DC motors rated up to 0.75 horsepower.

Voltage Rating 277 VAC maximum (1 or 2 pole)
 230 VDC maximum (2 pole only)

Horsepower Ratings

Volts	Maximum Horsepower		
	AC Single Phase		DC
	1 Pole	2 Pole	2 Pole Only
115 to 230	1	1	³ / ₄
277	1	1	—

Continuous Current Rating 16 A

Enclosures NEMA Type 1 surface mounting enclosures are sheet steel with a thermoplastic wrap-around cover for convenience in wiring. The NEMA Type 1 enclosure is also available in an oversized version that allows more space for wiring. A zinc alloy die casting is used for NEMA Type 4 enclosures, and a cast aluminum enclosure is offered for NEMA Type 3R, 7 & 9 applications.

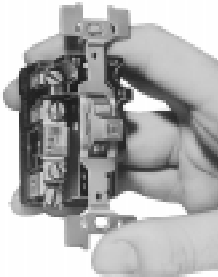

Type FO2

Pilot Light Red or green neon pilot light units are available factory installed in NEMA Type 1 surface and flush mounting and NEMA Type 4 enclosures. They are also available as a field modification kit for NEMA Type 1 enclosures and gray flush plates.

Use order number as is for red pilot light; add a G to the number for a green pilot light.

Handle Guard/Lock-Off An optional handle guard on NEMA Type 1 enclosed starters prevents accidental operation of the toggle operator and allows the toggle operator to be padlocked in either the On or Off position.

The handle guard can be factory installed on NEMA Type 1 enclosed starters. It is also available in kit form for field installation on NEMA Type 1 surface and flush mounting enclosures. Standard NEMA Type 4 and NEMA Type 3R, 7 & 9 enclosures include provision for locking in the Off position.

Terminals Binder head screw type terminals are suitable for #10 or smaller copper wire, and are accessible from the front. All terminals are clearly marked.

Mounting Open types without a pilot light fit standard single gang switch boxes, and can be used with any cover plate having a standard toggle cutout. Single-unit flush mounting types, including those with pilot light, are suitable for wall mounting in a standard switch box or for machine cavity mounting without a box.

Operator Available with toggle handle or with removable key type operator to discourage unauthorized operation.

Thermal Units Starters will not operate without properly installed thermal units. Install thermal units so that the markings face the front of the starter.





Manual Starters and Switches

Class 2510, 2512 Type F

Emergency Off Actuator

A toggle operator extender is available for NEMA Type 1 surface-mounted units. The extender has a red vinyl button that provides a fast and easy method for locating and switching the device's toggle operator into the Off position. The Emergency Off Actuator is available in kit form only for field installation.

Approvals

	Enclosed Unit	Open Unit	Explosion-Proof Unit
	File E42243 CCN NLRV	—	File E58760 CCN NPXZ
	File LR25490 Class 3211 05	File LR25490 Class 3211 05	File LR26817 Class 3218 04
	—	File E42243 CCN NLRV2	—

Typical Wiring Diagrams

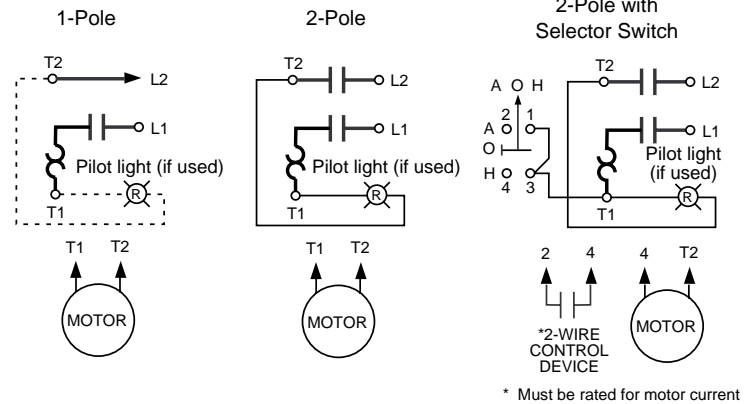

Single-Unit Types (Class 2510)

Type of Operator	No. of Poles	Features	NEMA Type 1 General Purpose Enclosure Surface Mounting		General Purpose Flush Mounting (Without Pull Box)			NEMA Type 4▲ Watertight and Dusttight Enclosure	NEMA Types 3R, 7 & 9▲ Class I Groups B, C, & D & Class II Groups E, F & G Enclosure	Open Type	Number of Thermal Units Required
			Standard	Oversized	Gray Flush Plate	Standard Stainless Steel Flush Plate	Jumbo Stainless Steel Flush Plate				
Basic Starter – Class 2510											
Toggle	1	Standard	FG1	FGJ1	FF1	FS1	FO1	1
		With Red Pilot Light	FG1P	FGJ1P	FF1P	FS1P	FSJ1P	FO1P	1
	2	Standard	FG2	FGJ2	FF2	FS2	FO2	1
		With Red Pilot Light	FG2P	FGJ2P	FF2P	FS2P	FSJ2P	FO2P	1
Key	1	Standard	FG3	FGJ3	FF3	FS3	FO3	1
		With Red Pilot Light	FG3P	FGJ3P	FF3P	FS3P	FSJ3P	FO3P	1
	2	Standard	FG4	FGJ4	FF4	FS4	FO4	1
		With Red Pilot Light	FG4P	FGJ4P	FF4P	FS4P	FSJ4P	FO4P	1
Starter with Handle Guard/Lock-Off – Class 2510											
Toggle	1	Standard	FG5	FGJ5	Order basic starter plus separate handle guard kit.			FW1	FR1	1
		With Red Pilot Light	FG5P	FGJ5P				FW1P	1
	2	Standard	FG6	FGJ6	FW2	FR2	1			
		With Red Pilot Light	FG6P	FGJ6P	FW2P	1			

▲ Furnished with one 3/4" pipe tap in bottom (reversible for top feed). To obtain 3/4" pipe tap top and bottom, add suffix letter "H" to type number.

Manual Starters and Switches Class 2510, 2512 Type F

Duplex Units (Class 2510)

Type of Operator	No. of Poles	Features	NEMA Type 1 General Purpose Enclosure Surface Mounting	General Purpose Flush Mounting (Without Pull Box)			Number of Thermal Units Required
				Gray Flush Plate for Wall or Cavity Mounting	Stainless Steel Flush Plate for Wall or Cavity Mounting		
One Starter in Duplex Enclosure – Class 2510							
Toggle	2	Standard	FG02		1
		With Red Pilot Light	FG02P		1
Key	2	With Red Pilot Light	FG04P		1
Two Starters in One Enclosure – Class 2510							
Toggle	2 Each Str.	Standard	FG22	FF22		2
		With Red Pilot Light on Each	FG22P	FF22P	FS22P		2
Key	2 Ea. Str.	With Red Pilot Light on Each	FG44P	FF44P	FS44P		2
Starter and "AUTO-OFF-HAND" SPDT Selector Switch (AC Only) – Class 2510							
Toggle	1	Standard	FG71	FF71		1
		With Red Pilot Light	FG71P	FF71P	FS71P		1
	2	Standard	FG72	FF72		1
		With Red Pilot Light	FG72P	FF72P	FS72P		1
Key	2	With Red Pilot Light	FG74P	FF74P	FS74P		1

Two Speed Starters (Class 2512)

Type F two-speed manual starters are designed for the control of small single-phase AC motors that have separate windings for high and low speed operation. Two toggle-operated starters are used, with overload protection included for each motor winding. Surface mounting devices, and those with a gray flush plate, utilize a mechanical interlock which allows direct control of the motor by means of the toggle operators.

Type of Operator	No. of Poles	Features	NEMA Type 1 General Purpose Enclosure Surface Mounting	General Purpose Flush Mounting (Without Pull Box)			Number of Thermal Units Required	
				Gray Flush Plate for Wall or Cavity Mounting	Stainless Steel Flush Plate for Wall or Cavity Mounting			
Two Speed Starters							Replacement Starter Class 2510	
Toggle	1	Standard with mechanical interlock	FG11	FF11	—	FO1T		2
		Standard with mechanical interlock and two red pilot lights	FG11P	FF11P	—	FO1PT		2
		Standard with HIGH-OFF-LOW selector switch and two red pilot lights	—	—	FS101P	FO1PT		2
	2	Standard with mechanical interlock:	FG22	FF22	—	FO2T		2
		Standard with mechanical interlock and two red pilot lights	FG22P	FF22P	—	FO2PT		2
		Standard with HIGH-OFF-LOW selector switch and two red pilot lights	—	—	FS202P	FO2PT	2	



Manual Starters and Switches

Class 2510, 2511, 2512 Type K



Type KG1A

MANUAL SWITCHES – TYPE K REVERSING, NON-REVERSING, TWO SPEED

Application Data

Type K motor starting switches provide manual “on-off” control of single- or three-phase AC motors, where overload protection is not required or is provided separately. These devices are suitable for use with three-phase AC motors rated up to 20 horsepower. Compact construction and a 600 volt rating make these switches suitable for a wide range of industrial and commercial uses. Typical applications include small machine tools, pumps, fans, conveyors, and many other types of electrical machinery. They may also be used on non-motor loads such as resistance heaters.

Voltage Rating 600 VAC maximum
230 VDC maximum

Continuous Current Rating 30 A at 600 VAC maximum

Horsepower Ratings

Class 2510	No. of Poles	Motor Type	Maximum Horsepower				DC Rating		
			115 V	230V	460 V	575 V	90 V	115 V	230V
KO1, KO3	2	1-Phase	2	2	3	3	1	2	1-1/2
KO2, KO4	3	3-Phase	2	7-1/2	10	10	1	2	1-1/2
KO5	2	1-Phase	2	3	7-1/2	10	1	2	1-1/2
KO6	3	3-Phase	2	7-1/2	15	20	1	2	1-1/2



Type KO2

Device	No. of Poles	Motor Type	Maximum Horsepower				DC Rating		
			115 V	230V	460 V	575 V	90 V	115 V	230V
Class 2511	2	1-Phase	2	2	3	3	1	2	1-1/2
	3	3-Phase	2	7-1/2	10	10	1	2	1-1/2
Class 2512	2	1-Phase	2	2	3	3	1	2	1-1/2
	3	3-Phase Constant or Variable Torque	2	7-1/2	10	10	1	2	1-1/2
	3	3-Phase Constant Horsepower	2	7-1/2	10	10	1	2	1-1/2

Enclosures

NEMA Type 1 surface mounting enclosures are sheet steel with a thermoplastic wrap-around cover for convenience in wiring. The NEMA Type 1 enclosure is also available in jumbo and oversized versions that allow more space for wiring. A zinc alloy die casting is used for NEMA Type 4 enclosures, and a cast aluminum enclosure is offered for NEMA Type 3R, 7 & 9 applications.

Mounting

Open types without a pilot light fit standard single gang switch boxes, and can be used with any cover plate having a standard toggle cutout. Single-unit flush mounting types, including those with pilot light, are suitable for wall mounting in a standard switch box or for machine cavity mounting without a box. For difficult wall surfaces, such as concrete block or tile, a jumbo size flush plate is recommended. See the dimensional drawings for additional details and mounting provisions of enclosed types.

Pilot Light

Red or green neon pilot light units are available factory installed in NEMA Type 1 surface and flush mounting and NEMA Type 4 enclosures. They are also available as a field modification kit for NEMA Type 1 enclosures and gray flush plates.

Use order number as is for red pilot light; add a G to the number for a green pilot light.

Operator

Available with toggle handle or with removable key type operator to discourage unauthorized operation.



Manual Starters and Switches Class 2510, 2511, 2512 Type K

Emergency Off Actuator

A toggle operator extender is available for NEMA Type 1 surface-mounted units. The extender has a red vinyl button that provides a fast and easy method for locating and switching the device's toggle operator into the Off position. The Emergency Off Actuator is available in kit form only for field installation.

Approvals

Same as for Type F; see page 4.

Typical Wiring Diagrams

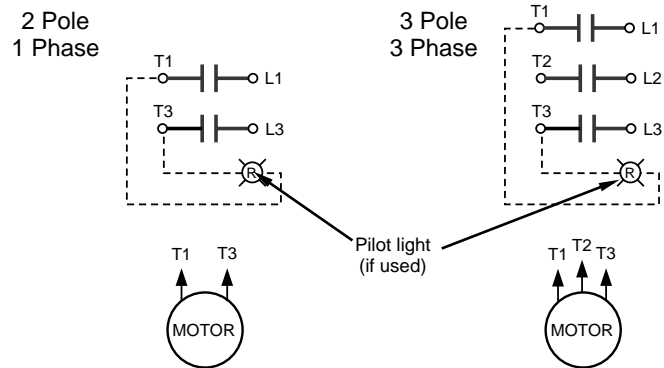

Non-Reversing (Class 2510)

Type of Operator	No. of Poles	Features	NEMA Type 1 General Purpose Enclosure Surface Mounting		General Purpose Flush Mounting (Without Pull Box)			NEMA Type 4 ▲ Watertight and Dusttight Enclosure	NEMA Types 3R, 7 & 9 ▲ Class I Groups B, C & D & Class II Groups E, F, and G Enclosure	Open Type
			Standard	Oversized	Gray Flush Plate	Standard Stainless Steel Flush Plate	Jumbo Stainless Steel Flush Plate			
Toggle	2	Standard	KG1	KGJ1	KF1	KS1	KW1	KR1	KO1
		With Pilot Light 115 VAC 230 VAC	KG1A KG1B	KGJ1A KGJ1B	KF1A KF1B	KS1A KS1B	KSJ1A KSJ1B	KW1A KW1B	KO1A* KO1B*
	3	Standard	KG2	KGJ2	KF2	KS2	KW2	KR2	KO2
		With Pilot Light 208-277 VAC 440-600 VAC	KG2B KG2C	KGJ2B KGJ2C	KF2B KF2C	KS2B KS2C	KSJ2B KSJ2C	KW2B KW2C	KO2B* KO2C*
	2	Standard	KG5	KGJ5	KW5	KO5
		With Pilot Light 115 VAC 230 VAC	KG5A KG5B	KW5A KW5B	KO5A KO5B
3	Standard	KG6	KGJ6	KW6	KO6	
	With Pilot Light 208-277 VAC 440-600 VAC	KG6B KG6C	KW6B KW6C	KO6B KO6C	
Key	2	Standard	KG3	KGJ3	KF3	KS3	KO3
		With Pilot Light 115 VAC 230 VAC	KG3A KG3B	KGJ3A KGJ3B	KF3A KF3B	KS3A KS3B	KSJ3A KSJ3B	KO3A KO3B
	3	Standard	KG4	KGJ4	KF4	KS4	KO4
		With Pilot Light 208-277 VAC 440-600 VAC	KG4B KG4C	KGJ4B KGJ4C	KF4B KF4C	KS4B KS4C	KSJ4B KSJ4C	KO4B KO4C

▲ Furnished with one 3/4" pipe tap in bottom (reversible for top feed). To obtain 3/4" pipe tap top and bottom, add suffix letter "H" to type number.

* Do not use as replacement interiors for NEMA Type 4 devices. For replacement unit, order Type KO1 or KO2 and separate pilot light kit.



Manual Starters and Switches

Class 2510, 2511, 2512 Type K



File E42243
CCN NLRV2



File LR25490
Class 3211 05

Reversing (Class 2511)

Type K reversing manual switches provide a compact means of starting, stopping, and reversing AC motors where overload protection is not required or is provided separately. They are suitable for use with three-phase squirrel cage motors and for single-phase motors which can be reversed by reconnecting motor leads. Two switches are used, one to connect the motor for forward rotation and one for reverse.

Type of Operator	No. of Poles	Motor Types for Which Suitable	Features (Including Mechanical Interlock)	NEMA Type 1 General Purpose Enclosure Surface Mounting	With Flush Plate for Cavity Mounting (Without Pull Box)	Replacement Switch Class 2510
Toggle	2	Single Phase, 3-Lead Repulsion-Induction	Standard	KG11	KF11	KO1T
			With Pilot Light 115 VAC 230 VAC	KG11A KG11B	KF11A KF11B	KO1AT KO1BT
	3	Three Phase; also Single Phase Capacitor, Split Phase, or 4-Lead Repulsion-Induction	Standard	KG22	KF22	KO2T
			With Pilot Light 110-120 VAC 208-220 VAC 440-600 VAC	KG22A KG22B KG22C	KF22A KF22B KF22C	KO2AT KO2BT KO2CT

Two Speed (Class 2512)

Type K two-speed manual switches may be used with separate winding three- or single-phase AC motors where overload protection is not required or is provided separately. Two switches are employed to give "on-off" control in each speed.

Type of Operator	No. of Poles	Motor Types for Which Suitable	Features (Including Mechanical Interlock)	NEMA Type 1 General Purpose Enclosure Surface Mounting	With Flush Plate for Cavity Mounting (Without Pull Box)	Replacement Switch Class 2510
Toggle	2	Single Phase, Two Winding (3-Lead)	Standard	KG11	KF11	KO1T
			With 2 Pilot Lights 115 VAC 230 VAC	KG11A KG11B	KF11A KF11B	KO1AT KO1BT
	3	Three Phase, Separate Winding (Wye-Connected)	Standard	KG22	KF22	KO2T
			With 2 Pilot Lights 208-240 VAC 440-600 VAC	KG22B KG22C	KF22B KF22C	KO2BT KO2CT

APPROXIMATE DIMENSIONS FOR OPEN TYPE

Type F Fractional Horsepower

Dimensions are typical for key operator devices.

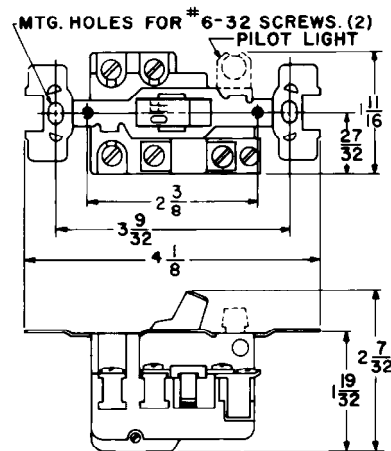

Manual Starters and Switches Type F and K Dimensions

Type K Motor Starting Switch

Dimensions are typical for key operator devices.

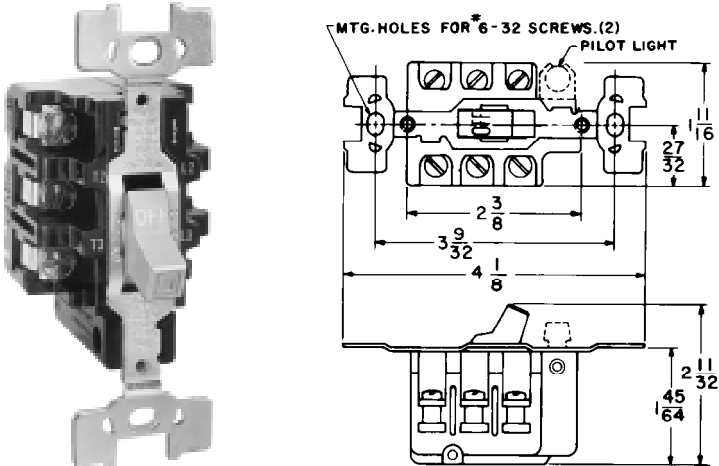

Dimensions for NEMA Type 1 General Purpose Surface Mounting Enclosures Standard Size

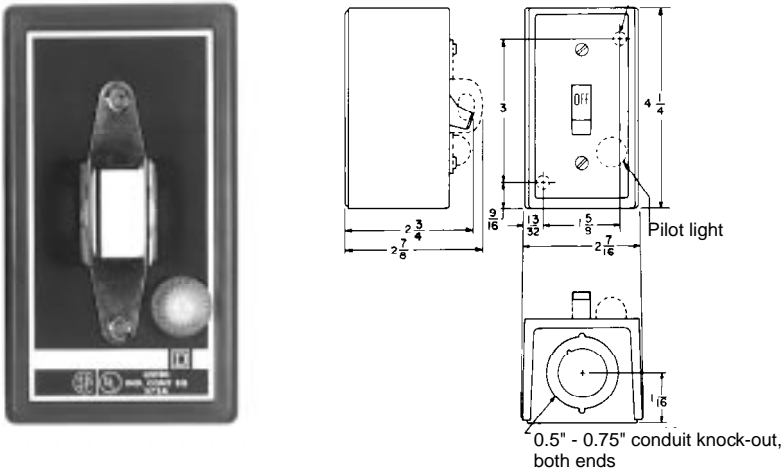

Manual Starters and Switches Type F and K Dimensions

Dimensions for NEMA Type 3R, 7, and 9 Cast Aluminum Enclosure for Hazardous Locations



Class 2510 Type KR2H
NEMA Type 3R, 7, & 9
Weight 3.5 lbs.

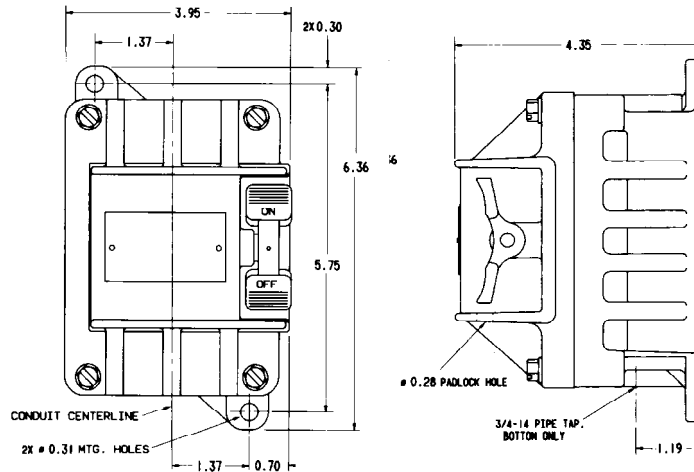

Device	Class	Type
Type F	2510	FR1, 2
Type K	2510	KR1, 2

Dimensions for NEMA Type 4 Watertight Die Cast Zinc Enclosure



NEMA Type 4
Weight 3.0 lbs.

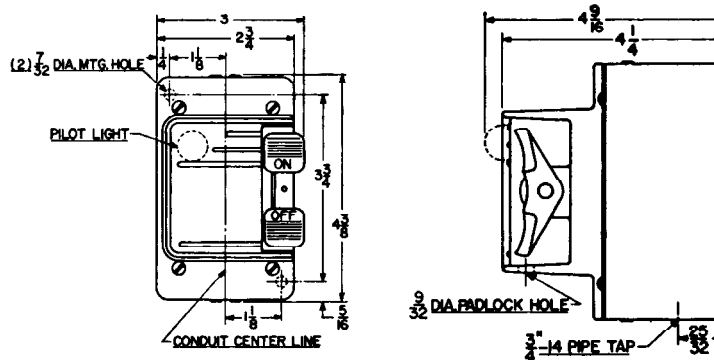

Device	Class	Type
Type F	2510	FW1, 1P, 2, 2P
Type K	2510	KW1, 1A, 1B KW2, 2B, 2C KW5, 5A, 5B KW6, 6B, 6C

Dimensions for Two-Unit Devices — NEMA Type 1 General Purpose Enclosure

Device	Type of Operator	Class	Type
One Starter	Toggle	2510	FGO2, FGO2P
	Key	2510	FGO4P
Two Starters	Toggle	2510	FG22, FG22P
	Key	2510	FG44P
One Starter and One Selector Switch▼	Toggle	2510	FG71, FG71P, FG72, FG72P
	Key	2510	FG74P
Reversing Switch◆	Toggle	2511	KG11, KG11A, KG11B, KG22A, KG22B, KG22C
Two-Speed Starter	Toggle	2512	FG11, FG11P, FG22, FG22P
Two-Speed Switch	Toggle	2512	KG11, KG11A, KG11B, KG22, KG22B, KG22C

▼ Selector switch is on the left; increases the overall depth to 3.5".

◆ Only one pilot light (located on the right) is used on Class 2511 switches.

A dimensional drawing is shown on the next page.



Manual Starters and Switches Type F and K Dimensions

Two-Unit NEMA Type 1 General Purpose Enclosure

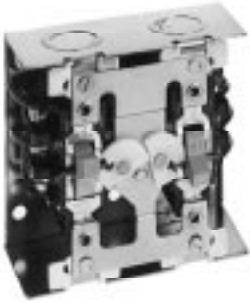

Class 2511 Type KG22
(Cover Removed)



Class 2511 Type KG22
(Cover)

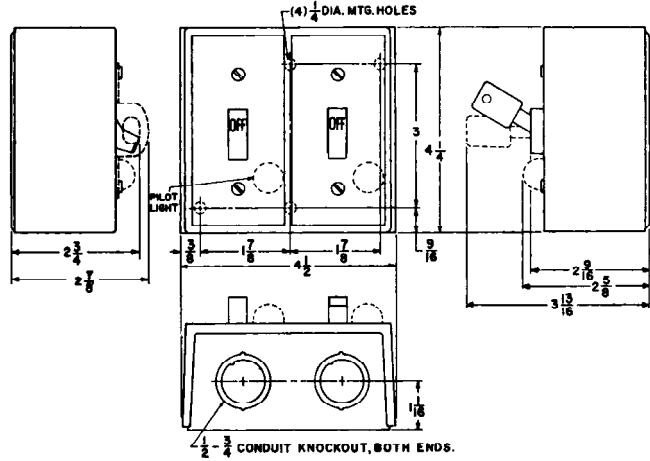

Two-Unit General Purpose Flush Mounting Plate



Class 2512 Type KF22

Device	Type of Operator	Class	Type	Dimensions			
				A	B	C	D
Two Starters	Toggle	2510	FF22, FF22P	5.25	3.75	5.25	1.44
			FS22P	4.56	3.5	4.5	1.44
	Key	2510	FF44P	5.25	3.75	5.25	1.44
			FS44P	4.56	3.5	4.5	1.44
One Starter and One Selector Switch▼	Toggle	2510	FF71, FF71P, FF72, FF72P	5.25	0.75	5.25	2.0
			FS71P, FS72P	4.56	3.5	4.5	2.0
	Key	2510	FF74P	5.25	3.75	5.25	2.0
			FS74P	4.56	3.5	4.5	2.0
Reversing Switch■	Toggle	2511	KF11, KF11A, KF11B KF22, KF22A, KF22B, KF22C	5.25	3.75	5.25	1.75
Two-Speed Starter	Toggle	2512	FF11, FF11P, FF22, FF22P	5.25	3.75	5.25	1.75
Two-Speed Switch	Toggle	2512	KF11, KF11A, KF11B KF22, KF22B, KF22C	5.25	3.75	5.25	1.75

▼ Selector switch is on the left; extends 1.63" from the mounting surface.
■ Dimensions include factory-wired power connections.

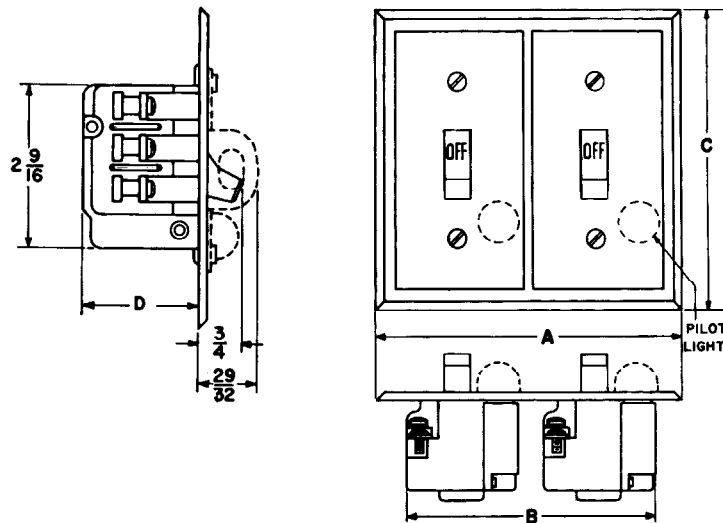

Manual Starters and Switches Integral Horsepower — Types M and T

CLASS 2510, 2511, 2512 INTEGRAL HORSEPOWER STARTERS — TYPES M AND T



Class 2510
Type M and T
in General Purpose
Enclosure

Application Data

Types M and T integral horsepower manual starters provide convenient “On-Off” operation of small single phase, polyphase, or DC motors. Typical applications include small machine tools, pumps, fans, and conveyors. They feature push button or toggle operators and reliable overload protection. Pilot lights and auxiliary contacts are available.

Size	Available in NEMA Sizes M-0, M-1, and M-1P
Poles	AC: Two poles single phase; three poles polyphase DC: 2 poles (without Low Voltage Protection only)
Voltage Rating	600 VAC maximum 250 VDC maximum
Overload Relays	Melting alloy thermal overload relays have provisions for one Type B thermal unit for single phase starters and three Type B thermal units for three phase starters. All thermal units must be installed and the device reset before the starter contacts will operate. After overload relays have tripped, allow one or two minutes for the alloy to solidify before resetting.
Operator	Available with a push button or toggle operator in open and NEMA 1 versions. NEMA Types 4 and 12 utilize a direct-acting push button only. NEMA Types 4X, 7 & 9 utilize an external toggle to actuate a push button device inside.
Mechanism Lock Off	Both open devices and starters in NEMA Type 1 surface and flush mounting, NEMA Types 4, 4X, 7 & 9, and 12 enclosures may be locked in the Off or Stop position. The NEMA Type 1 surface mounting, 4, 4X, 7 & 9, and 12 enclosures may also be locked closed to prevent unauthorized entry.
Terminals	



Size M-1, 3-Pole
Push Button Operated

NEMA Size	Power Terminals		Auxiliary Interlock Terminals	
	Type of Lug	Wire Size* Min. - Max.	Type of Lug	Wire Size* Min. - Max.
M-0	Pressure Wire	#14 - #8	Pressure Wire	#16 - #12
M-1	Pressure Wire	#14 - #8	Pressure Wire	#16 - #12
M-2	Box Lug	#14 - #6	Pressure Wire	#16 - #12

* Solid or stranded copper wire.

NEMA Size	Series	Number of Poles	Service Bulletin	Replacement Contact Kit	
				Class	Type
M-0	A	2 or 3	312AS	9998	ML1
	B	2 or 3	312AS	9998	ML1
M-1	A	2 or 3	312AS	9998	ML2
	B	2 or 3	312AS	9998	ML2
M-1P	A	2	312AS	9998	ML2
	B	2	312AS	9998	ML2

Approvals

All Except
NEMA Type 7 & 9



File E4847
CCN NLRV



File LR60905
Class 3211 05

NEMA Type 7 & 9 Only



File E78503
CCN NPXZ



File LR60905
Class 3218 04

Maintenance of Equipment

For proper performance, all equipment should be periodically inspected and maintained. Replacement contacts and interlocks are available in kit form to facilitate servicing and stocking. In addition, the service bulletin referenced in the table above contains an exploded view of the device with components clearly marked for easy identification by description and part number.



Manual Starters and Switches

Integral Horsepower — Types M and T



NEMA Type 4
Watertight and Dusttight
Stainless Steel

Starters will not operate without properly installing thermal units and then resetting the device. Thermal units must be installed so that markings face the front of the starter.

Accessories and Modification Kits

One auxiliary contact, either N.O. or N.C., can be easily added internally to any open or enclosed Type M or T manual starter. It occupies the space provided in either the upper right or left corners of the device. These contacts are for AC loads only.

A unique red pilot light assembly that clips into place is available factory-installed on NEMA Types 1, 4, 4X, 12, and flush enclosures. The assembly is also available as a field modification kit for NEMA Type 1 surface or flush mounting enclosures. The color cap assembly snaps into a knockout in the enclosure cover on the NEMA Type 1 enclosures. Pilot light kits are available for use on various voltages between 110 and 600 V. (Pilot light assemblies are not available for NEMA Type 7 & 9 enclosures.)

Class 2510 Non-Reversing Integral Horsepower Manual Starters (600 VAC Maximum)

No. of Poles	NEMA Size	Ratings			NEMA Type						Open Type	
		Motor Voltage	Max. HP		Type 1 Surface Mounting		Type 4 Watertight and Dusttight Enclosure Brushed Stainless Steel	Type 4X Watertight, Dusttight & Corrosion-Resistant Glass-Polyester Enclosure	Types 7 & 9* For Hazardous Locations Class I Grps C, D Class II Grps E, F, G	Type 12 [▲] Dusttight and Driptight Industrial Use Enclosure	Square Push Button Operator	Toggle Operator
			Poly-Phase	Single Phase	Square Push Button Operator	Toggle Operator						
2 Pole	M-0	115 230	1 2	MBG1	TBG1	MBW11★	MBW1★	MBR1★	MBA1★	MBO1	TBO1
	M-1	115 230	2 3	MCG1	TCG1	MCW11	MCW1	MCR1	MCA1	MCO1	TCO1
	M-1P	115 230	3 5	MCG2	TCG2	MCW12	MCW2	MCR2	MCA2	MCO2	TCO2
3 Pole	M-0	115 200-230 380-575 3 5	MBG2	TBG2	MBW12★	MBW2★	MBR2★	MBA2★	MBO2	TBO2
	M-1	115 200-230 380-575 7 1/2 10	MCG3	TCG3	MCW13	MCW3	MCR3	MCA3	MCO3	TCO3
DC 2 Pole	M-0	115 230	1 HP-D.C. 1 1/2 HP-D.C.	MBG4	TBG4	MBW14	MBW4	MBA4	MBO4	TBO4
	M-1	115 230	1 1/2 HP-D.C. 2 HP-D.C.	MCG5	TCG5	MCW15	MCW5	MCR5	MCA5	MCO5	TCO5

* NEMA Types 7 & 9 enclosures are cast-iron. NEMA Types 4X, 7 & 9 enclosures (cast aluminum) are available for outdoor use; to order these type of enclosures, replace the "R" in the catalog number with a "T". For additional information, contact your local Square D Field Sales Office.

▲ NEMA Type 12 enclosures may be field modified for outdoor applications.

★ Approved for group motor installations per NEC 430-53(c).

Class 2511 Reversing Manual Starters

Class 2511 reversing manual starters consist of two mechanically interlocked Class 2510 Type M or T manual starters. These starters are available in NEMA Type 1 surface-mounting enclosures or as open type. See page 19 for modifications.



NEMA Type 12
Driptight and Dusttight
Industrial Use

Number of Poles	NEMA Size	Ratings		NEMA Type 1 Surface Mounting		Open Type	
		Motor Voltage	Maximum Horsepower	Square Push Button Operator	Toggle Operator	Square Push Button Operator	Toggle Operator
3 Pole	M-0	200-230	3	MBG1	TBG1	MBO1	TBO1
		380-575	5				
	M-1	200-230	7 1/2	MCG1	TCG1	MCO1	TCO1
		380-575	10				

Manual Starters and Switches Integral Horsepower — Types M and T

Class 2512 Two-Speed Manual Starters

Class 2512 two-speed manual starters are for wye-connected separate winding motors only. They consist of two mechanically interlocked Class 2510 Type M or T manual starters. These starters are available with or without low voltage protection in NEMA Type 1 enclosures or open type. See page 19 for modifications.



NEMA Type 4X
Watertight, Dusttight, and
Corrosion-Resistant
Glass Polyester

Number of Poles	NEMA Size	Ratings			NEMA Type 1 Surface Mounting		Open Type	
		Motor Voltage	Constant Horsepower	Constant or Variable Torque	Square Push Button Operator	Toggle Operator	Square Push Button Operator	Toggle Operator
3 Pole	M-0	200-230	2	3	MBG1	TBG1	MBO1	TBO1
		380-575	3	5				
	M-1	200-230	5	7 1/2	MCG1	TCG1	MCO1	TCO1
		380-575	7 1/2	10				

Dimensions for Class 2510 Starters

Starters will not operate without properly installing thermal units and then resetting the device. Thermal units must be installed so that markings face the front of the starter.

Class 2510 Type M – Open Type
Sizes M-0, M-1, M-1P
App. Shipping Weight 3 pounds

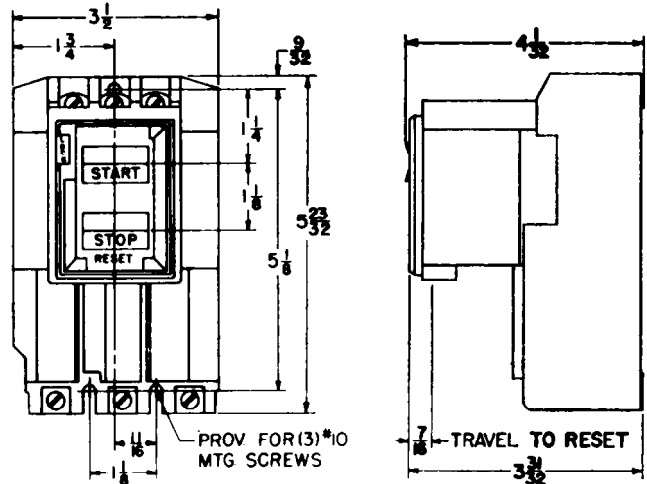

Class 2510 Types M & T Sizes M-0 and M-1
NEMA Type 1 General Purpose Enclosure
Approximate Shipping Weight 5 pounds



NEMA Type 7 & 9
Hazardous Location
Cast Iron

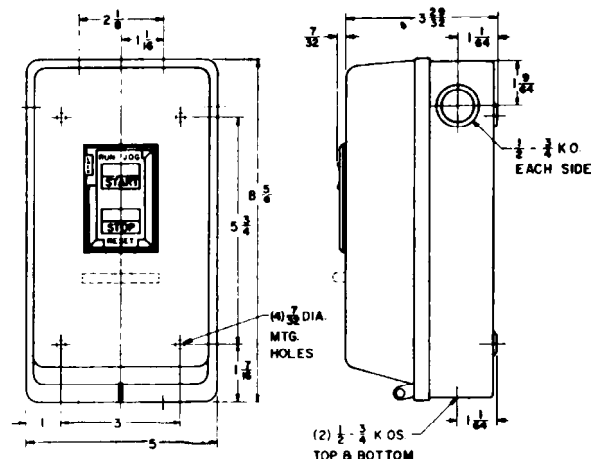

Manual Starters and Switches

Integral Horsepower — Types M and T

Dimensions for Class 2510 Starters

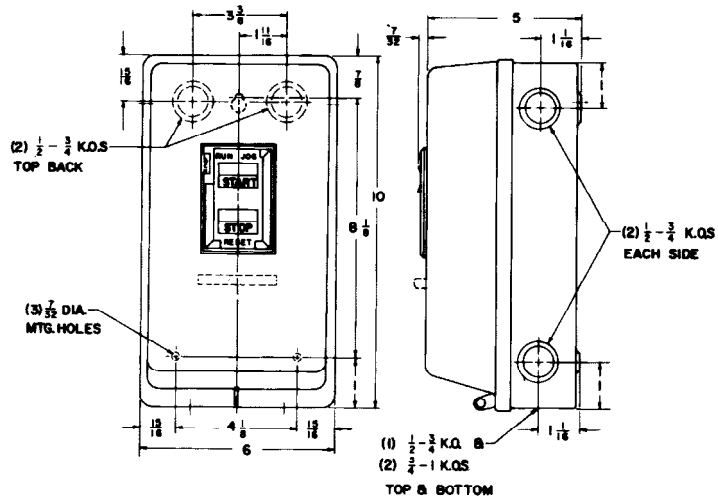

Class 2510 Types M & T Size M-1P
 NEMA Type 1 General Purpose Enclosure
 Approximate Shipping Weight 5 pounds

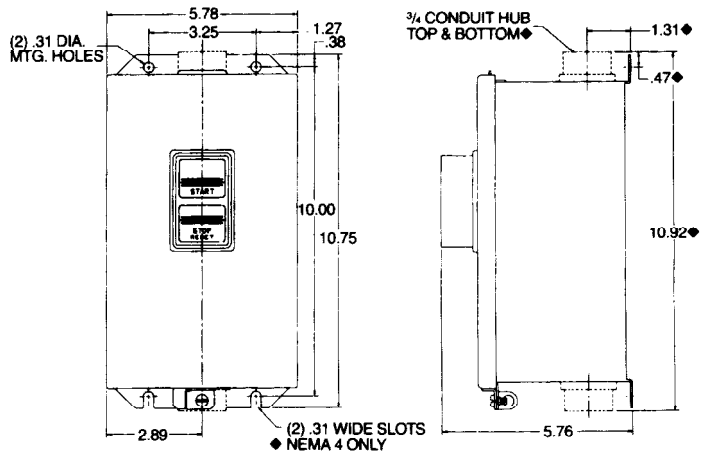

Class 2510 Type M Sizes M-0, M-1, and M-1P
 NEMA Type 4 Watertight Stainless Steel Enclosure
 NEMA Type 12 Dusttight Industrial Use Enclosure
 Approximate Shipping Weight 9 pounds

Manual Starters and Switches Integral Horsepower — Types M and T

Dimensions for Class 2510 Starters

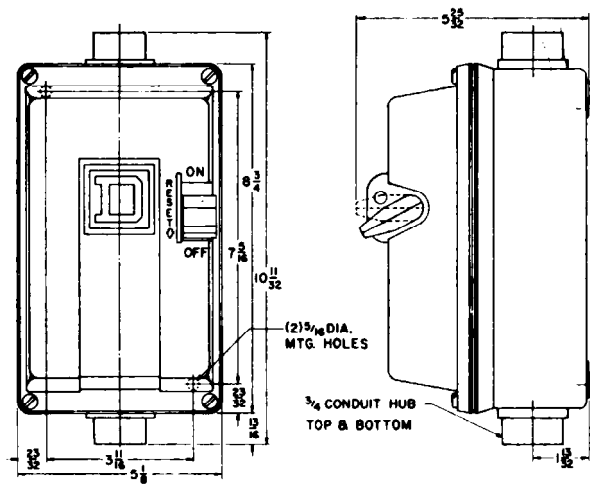

Class 2510 Type M Size M-0 (AC - DC) & M-1 (DC)
NEMA Type 4X Watertight, Corrosion-Resistant
Glass Polyester Enclosure
Approximate Shipping Weight 6 pounds

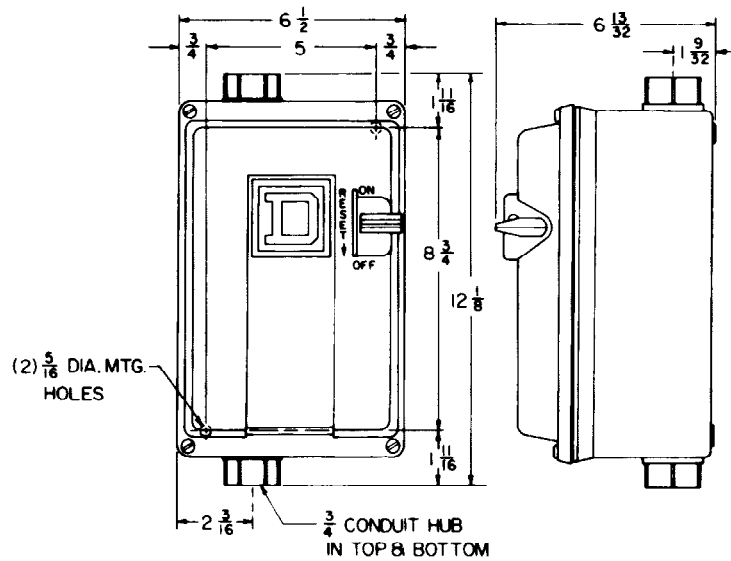

Class 2510 Type M Sizes M-1 and M-1P (AC)
NEMA Type 4X Watertight, Corrosion-Resistant
Glass Polyester Enclosure
Approximate Shipping Weight 6 pounds



Manual Starters and Switches Integral Horsepower — Types M and T

Dimensions for Class 2510, 2511, and 2512 Starters

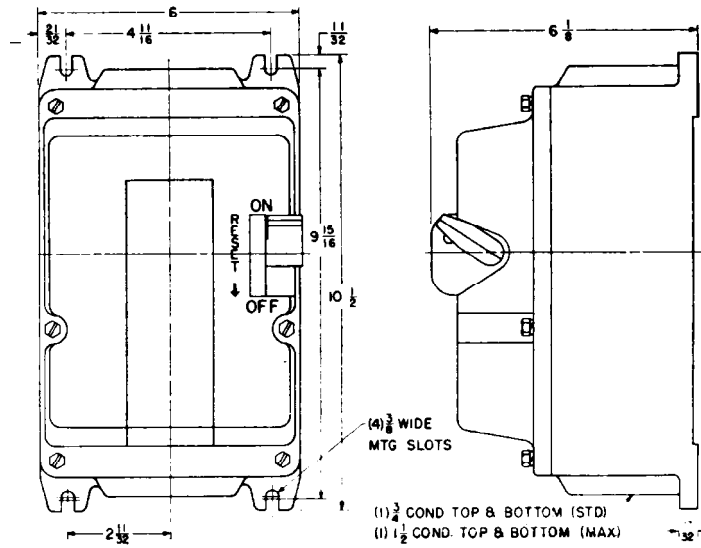

Class 2510 Type M Sizes M-0, M-1, and M-1P
NEMA Type 7 & 9 Hazardous Location
Cast Iron Enclosure
Approximate Shipping Weight 18 pounds

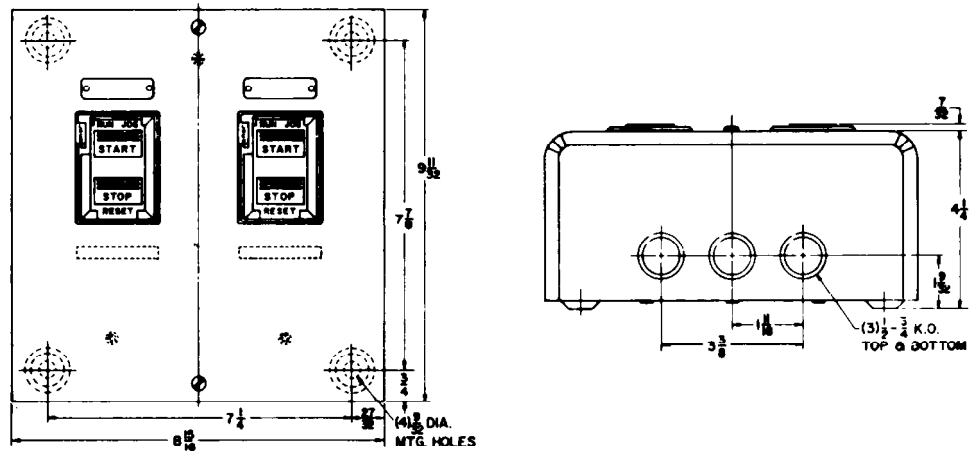

Class 2511 and 2512 Types M & T
Sizes M-0 and M-1
NEMA Type 1 General Purpose Enclosure
Approximate Shipping Weight 9 pounds

Manual Starters and Switches Accessories and Modifications

Accessories for Class 2510 Types F and K

Description	Class & Type
Handle Guard Kit with Padlock Provision‡	2510 FL1
Emergency Off Actuator	2510 PB1
Additional Key for Key Operated Devices	2510 FK1

‡ Standard on Type K devices.

Pilot Light Kits for Class 2510 Types F and K

Application	Voltage	Red Pilot Light	Green Pilot Light
		Class & Type	Class & Type
Type KF, KG, KW*	110–120 Vac	9999 PL11	9999 PL11G
	208–277 Vac	9999 PL12	9999 PL12G
	440–600 Vac	9999 PL13	9999 PL13G
Type FF or FG	115–240 Vac/dc	9999 PL10	9999 PL10G

* Lens cannot be replaced.

Replacement Parts

Description	Class and Type
Replacement Toggle Kits: Type FW and KW (NEMA Type 4) Type FR and KR (NEMA Type 7 & 9)	9998 HW1 9998 HR2
Replacement Handle Kits: Type MBA, MCA, MBW, MCW (NEMA Type 4 & 12) Type MBR, MCR, MBW, MCW (NEMA Type 4X, 7 & 9)	9998 HWA1 9998 HR3
Internal Lever	9998 IL1

Replacement Nameplates for Class 2510 Types F and K

Description	Application	Nameplate Marking	Nameplate Type Number – Class 2510			
			For Type K Switch		For Type F Starter (Includes "Reset" Indication)	
			Without Pilot Light	With Pilot Light	Without Pilot Light	With Pilot Light
1 ³ / ₄ " x 2 ¹³ / ₁₆ " Nameplate with Embossed Mounting Holes for #6 Head Screws	Standard commercial switch box cover or flush plate, including Square D stainless steel plates	Blank	FN1	—	FN2	—
		Special Marking (specify marking desired)	FN5	—	FN6	—
1 ²⁹ / ₃₂ " x 3 ²⁷ / ₃₂ " Flat Nameplate with Mounting Holes for #6 Pan Head Screws	Square D NEMA Type 1 surface mounted enclosure or gray flush plate	Blank	FN10	FN20	FN30	FN40
		High	FN11	FN21	FN31	FN41
		Low	FN12	FN22	FN32	FN42
		Forward	FN13	—	—	—
		Reverse	FN14	FN24	—	—
		Special marking (specify marking desired)	FN15	FN25	FN35	FN45

Enclosures

For use with Class 2510 Type	Oversized NEMA Type 1 General Purpose Class 9991 Type
FO1, FO1P, F02, FO2P, FO3, FO3P, FO4, FO4P	FE1
For use with Class 2510 Type	Oversized NEMA Type 1 Class 9991 Type
KO1, KO1A, KO1B KO2, KO2B, KO2C KO3, KO3A, KO3B KO4, KO4B, KO4C KO5 KO6	KE1
	Jumbo Type 1
	KE2
	NEMA Type 3R
	KE3

Modifications (Types M and T Only)

Description	Factory Modifications and Forms	Field Modifications
	Form Number	Kit Class & Type
Red Pilot Light†	P11	9999 MP1 (110–120 V) 9999 MP2 (208–240 V) 9999 MP3 (440–600 V)
Auxiliary Contacts♦	X1 (1 N.O.) X2 (1 N.C.)	9999 SX11 (N.O.) 9999 SX12 (N.C.)
Jumper Straps ▲	N/A	9998 SO31
Contact only	Y76	N/A
Electropolished Finish – N4	G16	N/A

† May only be field-added to NEMA Type 1 enclosures.

♦ For proper operation, only one auxiliary contact kit per device is allowed to be added.

▲ Used to control a single phase motor utilizing a three phase starter.



Manual Starters and Switches

Reversing Drum Switches

CLASS 2601 REVERSING DRUM SWITCHES

Reversing drum switches are designed to start and reverse motors by connecting them directly across-the-line. The devices may be used with squirrel cage motors; single-phase motors designed for reversing service; and series, shunt, and compound DC motors. The applications should be such that across-the-line starting of the motors is not objectionable, unless other means is provided for limiting starting current and torque. Class 2601 drum switches are field convertible from maintained to momentary operation.

Application Data

The reversing drum switches find application wherever manual reversing control is desired. They are particularly suited for use on machine tools, woodworking machines, and similar types of equipment. Examples include lathes, milling machines, planers, grinders, shapers, and boring mills. Other possible applications include door operators, small hoists, and conveyor belts.

Overload and low voltage protection are not incorporated in these reversing drum switches. Should the power fail, the contacts will remain closed, unless assembled for momentary operation, and the handle stays in the selected position. The motor will restart when the power returns.

Voltage	600 VAC Maximum 250 VDC Maximum
Contact Mechanism	Large movable contact segments are rigidly attached to the main operating shaft. They are fully insulated from each other and from the shaft. Stationary contact fingers are mounted in polymeric blocks. Both movable and stationary contacts are plated for maximum life. Extremely accessible terminals are provided for easy wiring. Type A is provided with screw type terminals and Type B is provided with pressure wire connector terminals. Contacts are not replaceable.

Operating Mechanism	As supplied from the factory, the operating mechanism is assembled for maintained position operation. That is, when the handle is moved to the forward or reverse position, it will remain there until moved. The mechanism can be easily converted, with no additional parts needed, to provide "spring return to off" operation. This conversion is accomplished by removing the handle screw and handle, turning the shaft 180 degrees, and then replacing the handle and handle screw.
---------------------	--

Optional Handles	Both the NEMA Type 1 and NEMA Type 4 devices offer as standard a one piece die cast handle. An optional ball and shaft or fluted handle is available. Drum switches with optional handles are available on a factory Quick-Ship basis. To order, add the letter B (for a ball and shaft type handle) or F (for fluted type handle) to the type number.
------------------	--

Enclosures	The polymeric NEMA Type 1 enclosure is suitable for indoor applications when normal atmospheric conditions prevail. The NEMA Type 4 enclosure is suitable for applications requiring watertight and dusttight capabilities. Generous wiring space is provided in both types. Two knockouts or openings for 1/2" conduit entries are located in the bottom plate of the AG/BG types, while two 1/2" conduit entries with hubs are provided as standard in AW/BW types.
------------	---

Enclosures	A single captive screw holds the cover on NEMA Type 1 enclosures, while three captive screws hold the cover on NEMA Type 4 enclosures. Removal of the cover allows free access to three sides of the switch mechanism. Large legible nameplates are securely attached to the enclosures to clearly indicate switching positions and to provide complete rating information. An instruction sheet showing motor connections is also provided.
------------	--



Type AG2



Type AW2



Ball and Shaft Type



Fluted Type

Manual Starters and Switches Reversing Drum Switches

NEMA Type 1, 3R, 4, and 13 without Overload Protection

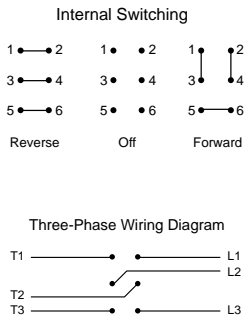

Volts	Ratings			NEMA Type				
	Maximum Horsepower			Type 1 General Purpose Enclosure	Type 4 Watertight & Dusttight Enclosure	Type 3R Rainproof Outdoor Enclosure	Type 1 Maintained & Momentary*	Type 13 Oiltight Flush Mounting
AC 1-Phase	AC Poly-Phase	DC						
115	1 1/2	1/4	AG2	AW2	AH2	AG2S2	AF2
200/230	2						
230	2						
460/575	2	BG1	BW1	N/A	BG1S4	BF1
115	1 1/2	2					
200/230	5					
230	3	2					
460/575	5	7 1/2					

* Maintained – “forward”; momentary – “reverse.” Not field convertible.



Approximate Dimensions

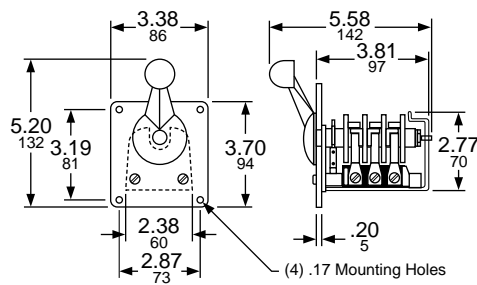

Class 2601 Type AF2

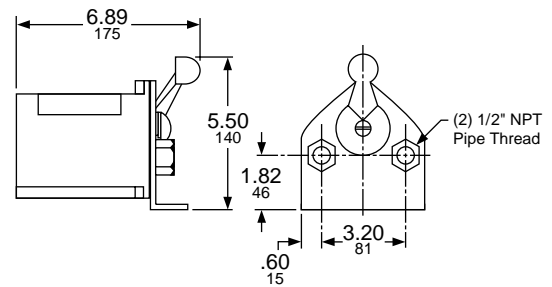

Class 2601 Types AW and BW

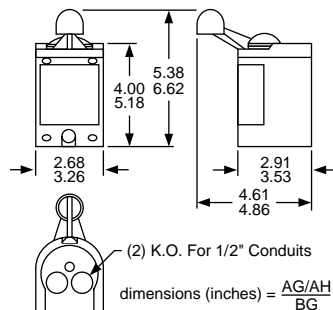

Class 2601 Types AG, AH, B

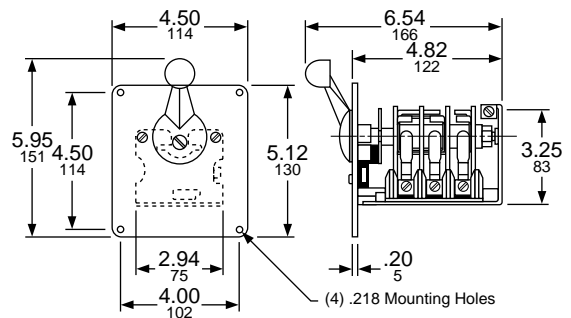

Class 2601 Type BF1





NOTES





NOTES



Square D Company
8001 Highway 64 East
Knightdale, NC 27545-9023 USA
(919) 266-3671

 and  are registered trademarks of Underwriters Laboratories, Incorporated.

 is a registered trademark of Canadian Standards Association, Incorporated.

Square D and  are registered trademarks of Square D Company.

Catalog No. 2510CT9701 12/97 © 1997 Square D All Rights Reserved.