

# Motor Controllers

## AC Semiconductor Motor Controller

### Types RSE 22 .. - B, RSE 4. .. - B, RSE 60 .. - B

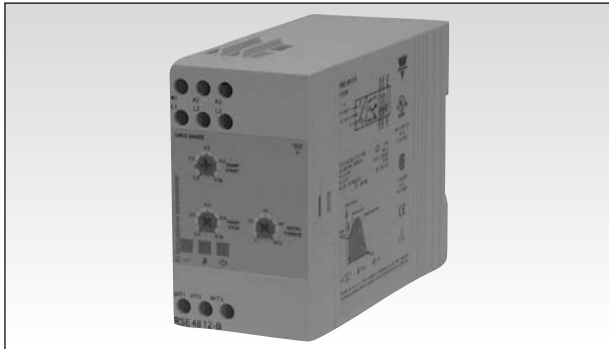

- Soft starting and stopping of 3-phase squirrel cage motors
- Rated operational voltage: Up to 600 VACrms, 50/60 Hz
- Rated operational current: 3 A or 12 AAC 53 b
- Potential-free control input
- LED-indications for supply and operation
- Transient overvoltage protection built-in
- Integral bypassing of semiconductors

### Product Description

Compact easy-to-use AC semiconductor motor controller. With this controller 3-phase motors with nominal load currents up to 12 A can be soft-started and/or soft-

stopped. Starting and stopping time as well as initial torque can be independently adjusted by built-in potentiometers.

### Ordering Key

**RSE 40 03 - B**

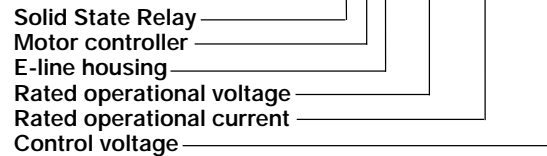

### Type Selection

Type	Rated operational voltage $U_e$	Rated operational current $I_e$	Control voltage $U_c$ *)
RSE: E-series, motor controller	22: 127/220 VACrms, 50/60 Hz 40: 230/400 VACrms, 50/60 Hz 48: 277/480 VACrms, 50/60 Hz 60: 346/600 VACrms, 50/60 Hz	03: 3 A 12: 12 A	-B: 24 to 110 VAC/DC & 110 to 480 VAC

\*) The control voltage should never be higher than the rated operational voltage.

### Input Specifications (Control Input)

Control voltage $U_c$ A1-A2:	24 - 110 VAC/DC $\pm 15\%$ , 12 mA
A1-A3:	110 - 480 VAC $\pm 15\%$ , 5 mA
Rated insulation voltage	630 V rms Overvoltage cat. III (IEC 60664)
Dielectric strength Dielectric voltage Rated impulse withstand volt.	2 kVAC (rms) 4 kV (1.2/50 $\mu$ s)

### Output Specifications

Utilization category	AC-53b Integral bypassing of semiconductors
Overload current profile (overload relay trip class)	
RSE ..03-B	3A: AC-53b:3-5:30
RSE ..12-B	12A: AC-53b:3-5: 180
Min. load current	
RSE ..03-B	100 mAAC rms
RSE ..12-B	200 mAAC rms



## Supply Specifications

Power supply	Overvoltage cat. III (IEC 60664)
Rated operational volt. (U <sub>e</sub> ) through terminals L1-L2-L3	(IEC 60038)
22	127/220 VAC rms ±15% 50/60 Hz -5/+5 Hz
40	230/400 VAC rms ±15% 50/60 Hz -5/+5 Hz
48	277/480 VAC rms ±15% 50/60 Hz -5/+5 Hz
60	346/600 VAC rms ±15% 50/60 Hz -5/+5 Hz
Voltage interruption	≤ 40 ms
Dielectric voltage	None
Rated impulse withstand volt.	4 kV (1.2/50 μs)
Rated operational power supplied from	2 VA L1-L3

## General Specifications

Accuracy	5.5 - 7.5 s on max. ≤ 0.5 s on min.
Ramp up	≤ 0.5 s on min.
Ramp down	6 - 10 s on max. ≤ 0.5 s on min.
Initial torque	70 - 100% on max. 5% on min.
EMC Immunity	Electromagnetic Compatibility acc. to EN 61000-6-2
Indication for Power supply ON	LED, green
Ramp up/down bypassing relay	LED, yellow
Environment	
Degree of protection	IP 20
Pollution degree	3
Operating temperature	-20° to +50°C (-4° to +122°F)
Storage temperature	-50° to +85°C (-58° to +185°F)
Screw terminals	
Tightening torque	Max. 0.5 Nm acc. to IEC 60947
Terminal capacity	2 x 2.5 mm <sup>2</sup>
Approvals	CSA (<7.5 HP @ 600 VAC), UL, cUL
CE-marking	Yes

## Mode of Operation

This motor controller is intended to be used to softstart/softstop 3-phase squirrel cage induction motors and thereby reduce the stress or wear on gear and belt/chain drives and to give smooth operation of machines. Soft starting and/or stopping is achieved by controlling the motor voltage.

The initial torque can be adjusted from 0 to 85% of the nominal torque.

The soft-start and soft-stop time can be adjusted from 0.5 to approx. 7s.

A green LED indicates supply. Two yellow LEDs indicate Ramp up/down and Running mode.

Overload protection is not provided in this motor controller and must therefore be installed separately.

The controller is switching 2 lines. The 3rd line is continuously connected to the load.

## Semiconductor Data

Rated operational current	I <sup>2</sup> t for fusing t = 1 - 10 ms	I <sub>TSM</sub>	di/dt
3 A	72 A <sup>2</sup> s	120 A <sub>p</sub>	50 A/μs
12 A	610 A <sup>2</sup> s	350 A <sub>p</sub>	50 A/μs

## Functional Diagram

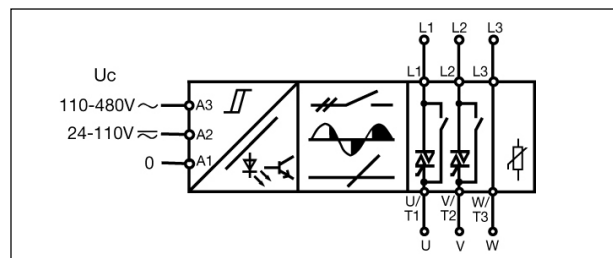

## Operation Diagram 1

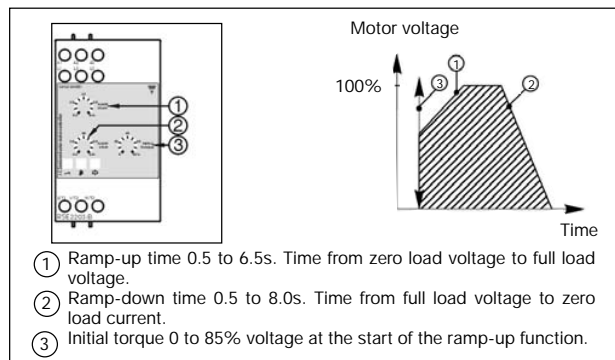

## Operation Diagram 2

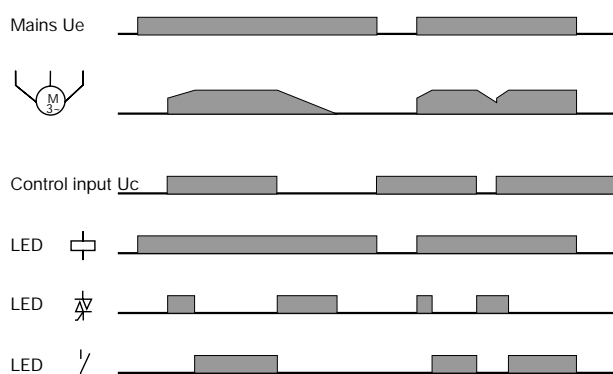

Specifications are subject to change without notice (30.09.2005)

## Dimensions

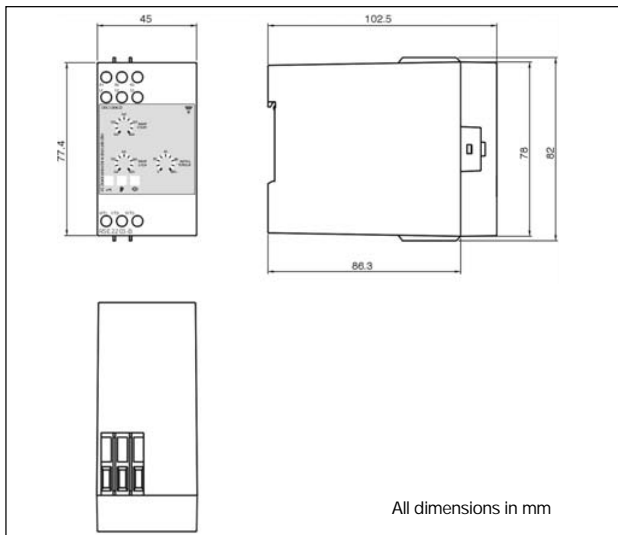

## Housing Specifications

Weight	270 g
Housing material	PC/ABS Blend
Colour	Light grey
Terminal block	PBTP
Colour	Light grey
Bottom clip	POM
Colour	Black
Diode cover	PC
Colour	Grey Transparent
Front knob	PA
Colour	Grey

## Applications

### Changing from Direct ON Line start to soft start (Line controlled soft-start) (Fig. 1 & Fig. 2)

Changing a Direct On Line start into a soft start is very simple with the RSE soft-starting relay:

- 1) Cut the cable to the motor and insert the RSE relay.
- 2) Connect control input to two of the incoming lines. Set initial torque to minimum and ramp up and down to maximum.
- 3) Power up again - adjust the start torque so the motor starts turning immediately after power is applied, and adjust ramp time to the appropriate value.

When C1 is operated, the motor controller will perform soft-start of the motor. When C1 is switched off, the motor will stop, the motor controller will reset and after 0.5 s a new soft-start can be performed.

Please note that the controller does not insulate the motor from the mains. Contactor C1 is therefore needed as a service switch for the motor.

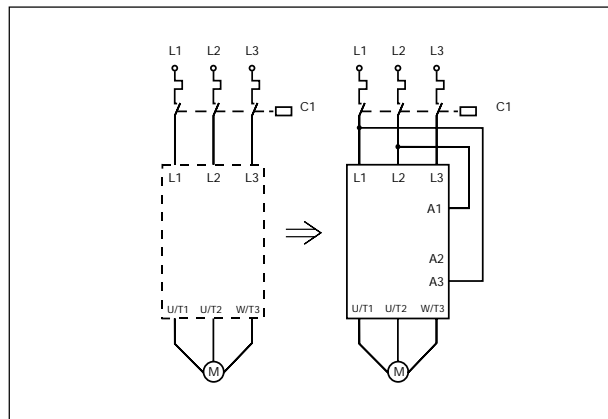

Fig. 1

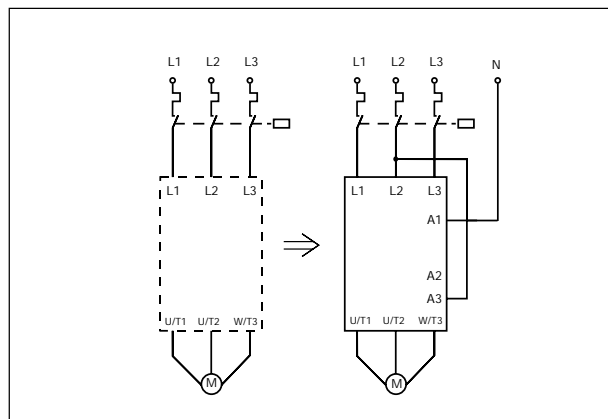

Fig. 2 For voltages higher than 480 VAC

### Soft-start and soft-stop (Fig. 3)

When S1 is closed, soft-start of the motor will be performed according to the setting of the ramp-up potentiometer and the setting of the initial torque potentiometer. When S1 is opened, soft-stop will be performed according to the setting of the ramp-down potentiometer.

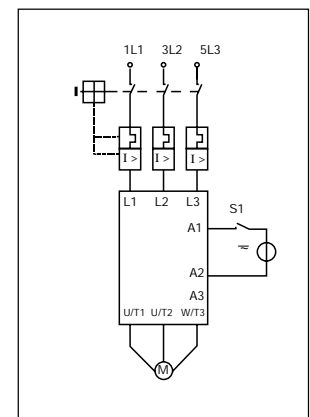

Fig. 3



## Applications

### Time between rampings

To prevent the semiconductors from overheating, a certain time between ramping should be allowed. The time between rampings depends on the motor current during ramping and ramp time (see tables below).

### Note:

Table is valid for ambient temperature 25°C. For higher ambient temperature add 5%/°C to values in the tables. The shaded areas in the tables are for blocked rotor. Do not repeat rampings with blocked rotor.

### Fusing Considerations

The motor controller provides by-passing of the semiconductors during running operation. Therefore the semiconductors can only be damaged by short-circuit currents during ramp-up and ramp-down function.

the fault current. If the motor is installed in an environment where the supply to the motor cannot be damaged, the short circuit protection can be considered to be acceptable if the controller is protected by a 3-pole thermal-magnetic overload relay (see table below).

### RSE .. 03 - B

#### Time between rampings

Ramp time (sec.) \ I ramp (A)	1	2	5	10
18	15 sec	30 sec	1.5 min	2.5 min
15	12 sec	20 sec	60 sec	1.5 min
12	10 sec	20 sec	50 sec	70 sec
9	8 sec	12 sec	30 sec	50 sec
6	5 sec	9 sec	25 sec	40 sec
3	2 sec	5 sec	20 sec	35 sec
1.5	1 sec	2 sec	5 sec	5 sec

A 3-phase induction motor with correctly installed and adjusted overload protection does not short totally between lines or directly to earth as some other types of loads, e.g. heater bands. In a failing motor there will always be some part of a winding to limit

If the risk of short circuit of the motor cable, the controller or the load exists, then the controller must be protected by ultrafast fuses, e.g. for a 3 A type: Ferraz 660 gRB 10-10, for an 12 A type: Ferraz 660 gRB 10-25. Fuseholder type PST 10.

### RSE .. 12 - B

#### Time between rampings

Ramp time (sec.) \ I ramp (A)	1	2	5	10
72	2.5 min	5 min	40 min	N/A
60	1.5 min	3 min	13 min	17 min
48	50 sec	1.5 min	5 min	10 min
36	30 sec	1 min	3 min	7 min
24	15 sec	40 sec	1.5 min	2.5 min
12	10 sec	20 sec	50 sec	70 sec
6	5 sec	9 sec	20 sec	40 sec

### Recommended thermal-magnetic overload relay

#### Selection Chart

Thermal-magnetic overload relay and motor controller

Motor full load current (AACrms)	0.1 - 0.16	0.16 - 0.25	0.25 - 0.4	0.4 - 0.63	0.63 - 1.0	1.0 - 1.6	1.6 - 2.5	2.5 - 4	4 - 6.3	6.3 - 9	9 - 12
Overload relay type GV 2- Manufacturer: Telemecanique	M 01	M 02	M 03	M 04	M 05	M 06	M 07	M 08	M 10	M 14	M 16
Overload relay type MS 325- Manufacturer: ABB	0.16	0.25	0.4	0.63	1	1.6	2.5	4	6.3	9	12.5
Motor protection circuit breaker type KTA 3-25- Manufacturer: Allan-Bradley/Sprecher + Schuh	0.16	0.25	0.4	0.63	1	1.6	2.5	4	6.3	10	16
Motor controller type: 127/220 V mains 230/400 V mains 270/480 V mains 400/690 V mains	RSE 22 03 - B RSE 40 03 - B RSE 48 03 - B RSE 60 03 - B							RSE 22 12 - B RSE 40 12 - B RSE 48 12 - B RSE 60 12 - B			

### Example:

Line voltage: 230/400 V  
Motor 1.5 HP: 1.1 kW  
Full load current: 2.9 A

### Step 1:

Select overload relay:  
In this example GV 2 - M 08, MS 325 - 4 or KTA 3-25-4A must be used.

### Step 2:

Select motor controller:  
For line voltage 230/400 V and overload, relay GV 2 - M 08 or MS 325 - 4 with a setting of 2.9 A type RSE 40 03 -B can be selected.

N.B.: For motors with full load current from 12 A to 40 A, see types RSH and RSC/RSO.