

# RE 40 Ø40 mm, Graphite Brushes, 150 Watt

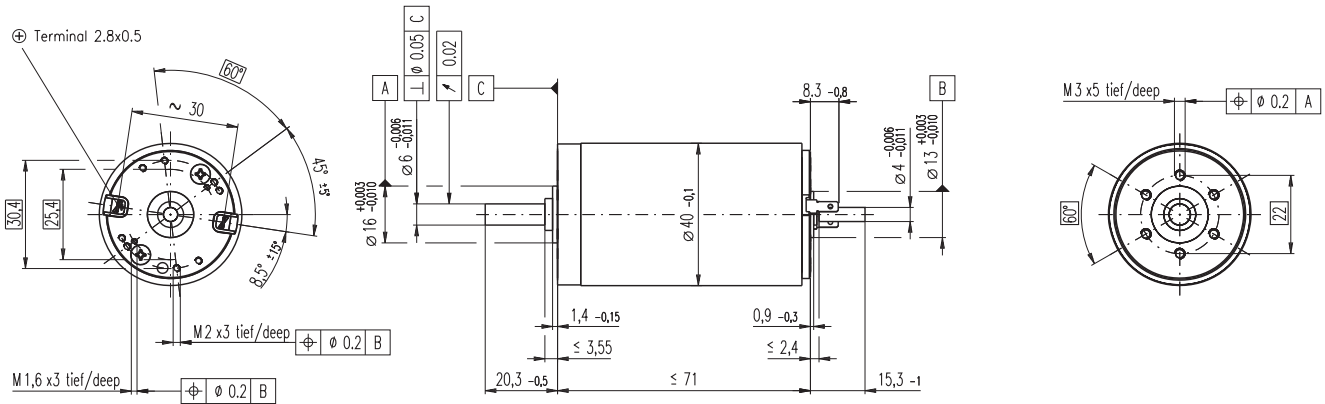

## M 1:2

- Stock program
- Standard program
- Special program (on request)

### Order Number

148866 148867 148877 218008 218009 218010 218011 218012 218013 218014

Motor Data		148866	148867	148877	218008	218009	218010	218011	218012	218013	218014
<b>Values at nominal voltage</b>											
1	Nominal voltage	V	12.0	24.0	48.0	48.0	48.0	48.0	48.0	48.0	48.0
2	No load speed	rpm	6920	7580	7580	6420	5560	3330	2690	2130	1710
3	No load current	mA	241	137	68.6	53.7	43.7	21.9	16.7	12.5	9.67
4	Nominal speed	rpm	6370	6930	7000	5810	4920	2700	2050	1500	1080
5	Nominal torque (max. continuous torque)	mNm	94.9	170	184	183	177	187	187	189	189
6	Nominal current (max. continuous current)	A	6.00	5.77	3.12	2.62	2.20	1.38	1.12	0.898	0.721
7	Stall torque	mNm	1680	2280	2500	1990	1580	995	796	641	512
8	Starting current	A	102	75.7	41.4	28.0	19.2	7.26	4.68	3.00	1.92
9	Max. efficiency	%	88	91	92	91	91	89	88	87	86
<b>Characteristics</b>											
10	Terminal resistance	Ω	0.117	0.317	1.16	1.72	2.50	6.61	10.2	16.0	24.9
11	Terminal inductance	mH	0.0245	0.0823	0.329	0.460	0.612	1.70	2.62	4.14	6.40
12	Torque constant	mNm / A	16.4	30.2	60.3	71.3	82.2	137	170	214	266
13	Speed constant	rpm / V	581	317	158	134	116	69.7	56.2	44.7	35.9
14	Speed / torque gradient	rpm / mNm	4.15	3.33	3.04	3.23	3.53	3.36	3.39	3.35	3.37
15	Mechanical time constant	ms	6.03	4.81	4.39	4.36	4.35	4.31	4.31	4.31	4.32
16	Rotor inertia	gcm <sup>2</sup>	139	138	138	129	118	123	121	123	120

### Specifications

- Thermal data**
- 17 Thermal resistance housing-ambient 4.65 K / W
  - 18 Thermal resistance winding-housing 1.93 K / W
  - 19 Thermal time constant winding 41.6 s
  - 20 Thermal time constant motor 1120 s
  - 21 Ambient temperature -30 ... +100°C
  - 22 Max. permissible winding temperature +155°C
- Mechanical data (ball bearings)**
- 23 Max. permissible speed 12000 rpm
  - 24 Axial play 0.05 - 0.15 mm
  - 25 Radial play 0.025 mm
  - 26 Max. axial load (dynamic) 5.6 N
  - 27 Max. force for press fits (static) (static, shaft supported) 110 N
  - 28 Max. radial loading, 5 mm from flange 1200 N

- Other specifications**
- 29 Number of pole pairs 1
  - 30 Number of commutator segments 13
  - 31 Weight of motor 480 g

Values listed in the table are nominal.  
Explanation of the figures on page 49.

- Option**
- Preloaded ball bearings

### Operating Range

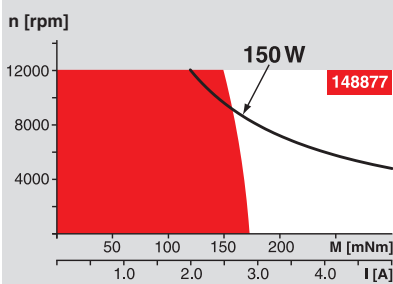

### Comments

- Continuous operation**  
In observation of above listed thermal resistance (lines 17 and 18) the maximum permissible winding temperature will be reached during continuous operation at 25°C ambient.  
= Thermal limit.
- Short term operation**  
The motor may be briefly overloaded (recurring).
- Assigned power rating**

### maxon Modular System

Overview on page 16 - 21

- Planetary Gearhead**  
Ø42 mm  
3 - 15 Nm  
Page 240
- Planetary Gearhead**  
Ø52 mm  
4 - 30 Nm  
Page 243

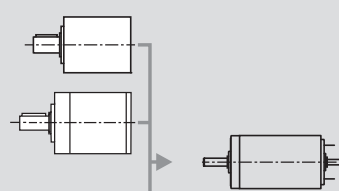

- Recommended Electronics:**
- ADS 50/5 283
  - ADS 50/10 283
  - ADS\_E 50/5 283
  - ADS\_E 50/10 283
  - EPOS2 24/5 303
  - EPOS2 50/5 303
  - EPOS 70/10 303
  - EPOS P 24/5 306
  - Notes 18

- Encoder MR**  
256 - 1024 CPT,  
3 channels  
Page 265
- Encoder HED\_ 5540**  
500 CPT,  
3 channels  
Page 268 / 270
- Brake AB 28**  
Ø45 mm  
24 VDC, 0.4 Nm  
Page 316
- Industrial Version Encoder HEDL 9140**  
Page 273
- Brake AB 28**  
Page 317