

VZ

V1000

More performance & Quality in less space

- Current vector control
- High starting torque (200% / 0.5 Hz)
- 1:100 speed control range
- Double rating ND 120%/1min and HD 150%/1 min
- IM&PM motor control
- Online Tuning
- Low-noise Low carrier technology
- 10 years lifetime design
- Built-in filter
- Screw-less terminals
- Control Terminals with memory backup
- 24 VDC control board power supply option
- Fieldbus communications: Modbus, Profibus, CanOpen, DeviceNet, Lonworks, CompoNet, Ethernet, ML-II
- Safety embedded: EN954-1 safety cat. 3, EN6158 SIL II and EN60204-1 Stop category 0
- CE, UL, cUL and TUV

Ratings

- 200 V Class single-phase 0.1 to 4 kW
- 200 V Class three-phase 0.1 to 15 kW
- 400 V Class three-phase 0.2 to 15 kW



System configuration

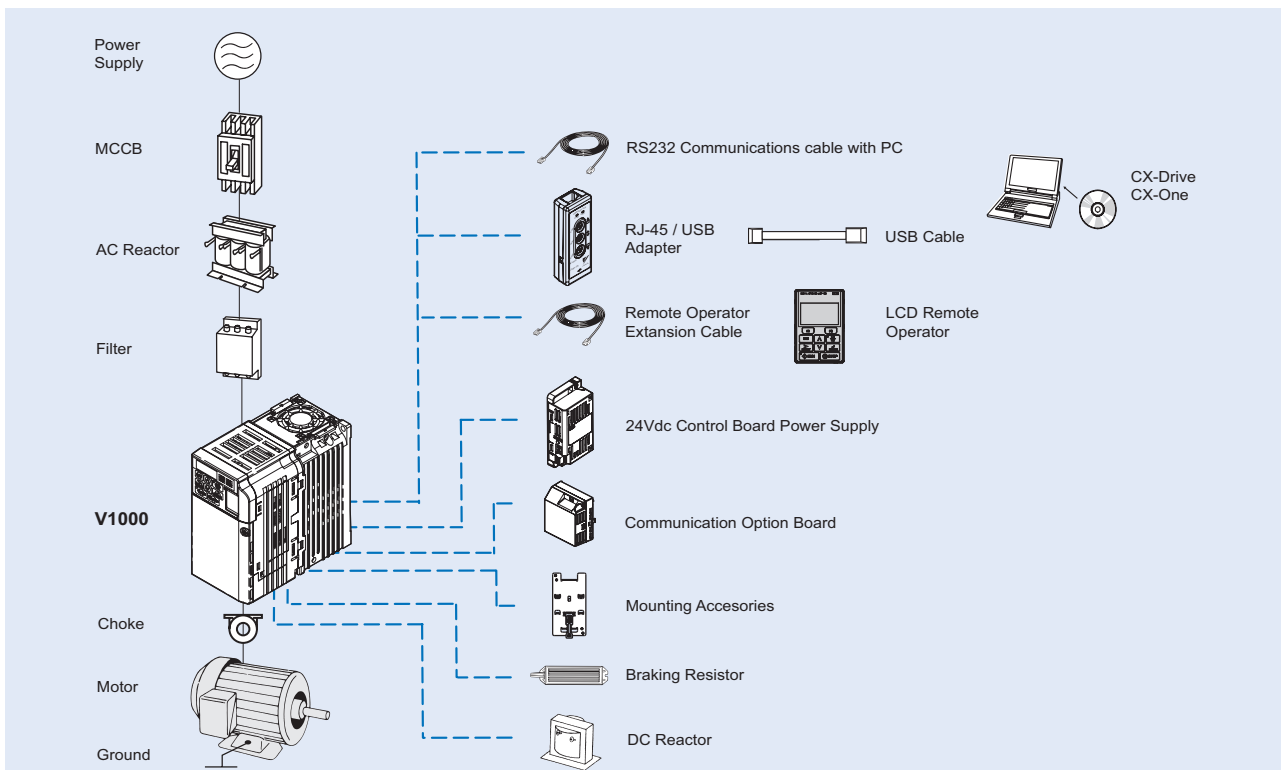

Specifications

Type designation

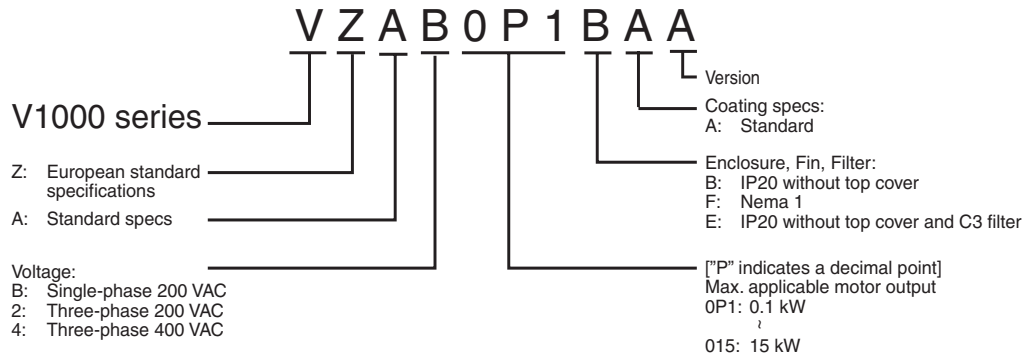

200 V class

Single-phase: VZA□		B0P1	B0P2	B0P4	B0P7	B1P5	B2P2	B4P0 ¹	-	-	-	-
Three-phase: VZA□		20P1	20P2	20P4	20P7	21P5	22P2	24P0	25P5	27P5	2011	2015
Motor kW ²	For HD setting	0.12	0.25	0.4	1.1	1.5	2.2	4.0	5.5	7.5	11	15
	For ND setting	0.18	0.37	0.55	1.1	2.2	3.0	5.5 ¹	7.5	11	15	18.5
Output characteristics	Inverter capacity kVA	0.3	0.6	1.1	1.9	3.0	4.2	6.7	9.5	13	18	23
	Rated output current (A) at HD	0.8	1.6	3.0	5.0	8.0	11.0	17.5	25.0	33.0	47.0	60.0
	Rated output current (A) at ND	1.2	1.9	3.5	6.0	9.6	12.0	19.6	30.0	40.0	56.0	69.0
	Max. output voltage	Proportional to input voltage: 0..240 V										
	Max. output frequency	400 Hz										
Power supply	Rated input voltage and frequency	Single-phase 200..240 V 50/60 Hz 3-phase 200..240 V 50/60 Hz										
	Allowable voltage fluctuation	-15%..+10%										
	Allowable frequency fluctuation	+5%										

1. Only HD settings is available for this model
2. Based on a standard 4-pole motor for maximum applicable motor output:
Heavy Duty (HD) mode with a 150% overload capacity
Normal Duty (ND) mode with a 120% overload capacity

400 V class

Three-phase: VZA□		40P2	40P4	40P7	41P5	42P2	43P0	44P0	45P5	47P5	4011	4015
Motor kW ¹	For HD setting	0.37	0.55	1.10	1.5	2.2	3.0	4.0	5.5	7.5	11	15
	For ND setting	0.37	0.75	1.5	2.2	3.0	4.0	5.5	7.5	11	15	18.5
Output characteristics	Inverter capacity kVA	0.9	1.4	2.6	3.7	4.2	5.5	7.2	9.2	14.8	18	24
	Rated output current (A) at HD	1.2	1.8	3.4	4.8	5.5	7.2	9.2	14.8	18.0	24	31
	Rated output current (A) at ND	1.2	2.1	4.1	5.4	6.9	8.8	11.1	17.5	23	31	38
	Max. output voltage	0..480V (proportional to input voltage)										
	Max. output frequency	400 Hz										
Power supply	Rated input voltage and frequency	3-phase 380..480 VAC, 50/60 Hz										
	Allowable voltage fluctuation	-15%..+10%										
	Allowable frequency fluctuation	+5%										

1. Based on a standard 4-pole motor for maximum applicable motor output:
Heavy Duty (HD) mode with a 150% overload capacity
Normal Duty (ND) mode with a 120% overload capacity

Specifications

Common specifications

Model number VZA□		Specifications
Control functions	Control methods	Sine wave PWM (V/f control, sensorless current vector control)
	Output frequency range	0.1..400 Hz
	Frequency tolerance	Digital set value: ±0.01% (-10..+50 °C)
		Analogue set value: ±0.1% (25 ±10 °C)
	Resolution of frequency set value	Digital set value: 0.01 Hz (<100 Hz), 0.1 Hz (>100 Hz)
		Analogue set value: 1/1000 of maximum frequency
	Resolution of output frequency	0.01 Hz
	Overload capability	Heavy duty use: 150% rated output current for one minute Normal duty use: 120% rated output current for one minute
	Frequency set value	0..10 V (20 kΩ), 4..20 mA (250 Ω), 0..20 mA (250 Ω) Pulse train input, frequency setting value (selectable)
Braking torque (short term peak torque)	Short-term average deceleration torque: 150% (up 1.5 kW), 100% (for 1.5 kW), 50% (for 2.2 kW), 20% (for bigger size) Continuous regenerative torque: Approx 20% (125% with optional braking resistor, 10%ED, 10 s, braking transistor built in)	
V/f Characteristics	Possible to program any V/f pattern	
Functionality	Inputs signals	Seven of the following input signals are selectable: Forward/reverse run (3-wire sequence), fault reset, external fault (NO/NC contact input), multi-step speed operation, Jog command, accel/decel time select, external baseblock, speed search command, UP/DOWN command, accel/decel hold command, LOCAL/REMOTE selection, communication/control circuit terminal selection, emergency stop fault, emergency stop alarm, self test
	Output signals	Following output signals are selectable (NO/NC contact output, 2 photo-coupler outputs): Fault, running, zero speed, speed agree, frequency detection (output frequency <= or => set value), during overtorque detection, minor error, during baseblock, operation mode, inverter run ready, during fault retry, during undervoltage detection, reverse running, during speed search, data output through communication.
	Standard functions	Open-loop vector control, full-range automatic torque boost, slip compensation, 17-step speed operation (max.), restart after momentary power loss, DC injection braking current at stop/start (50% of inverter rated current, 0.5 sec, or less), frequency reference bias/gain, MEMOBUS communications (RS-485/422, max. 115K bps), fault retry, speed search, frequency upper/lower limit setting, overtorque detection, frequency jump, accel/decel time switch, accel/decel prohibited, S-curve accel/decel, PID control, energy-saving control, constant copy.
	Analogue inputs	2 analogue inputs, 0..10 V, 4..20 mA, 0..20 mA
	Braking/acceleration times	0.01..6000 s
	Display	Optionally frequency, current or set value Error and status LED
Protection functions	Motor overload protection	Electronic thermal overload relay
	Instantaneous overcurrent	Motor coasts to a stop at approx. 250% of inverter rated current
	Overload	Heavy Duty: Motor coasts to a stop after 1 minute at 150% of inverter rated output current Normal Duty: Motor coasts to a stop after 1 minute at 120% of inverter rated output current
	Overvoltage	Motor coasts to a stop if DC bus voltage exceed 410 V (double for 400 V class)
	Undervoltage	Stops when DC bus voltage is approx. 190 V or less (double for 400 V class) (approx. 150 V or less for single-phase series)
	Momentary power loss	Following items are selectable: not provided (stop if power loss is 15 ms or longer), continuous operation if power loss is approx. 0.5 s or shorter, continuous operation
	Cooling fin overheat	Protected by thermister
	Stall prevention level	Stall prevention during acceleration/deceleration and constant speed operation
	Ground fault	Protected by electronic circuit (operation level is approx. 250% of rated output current)
	Power charge indication	Indicates until the main circuit voltage reaches 50 V.
Ambient conditions	Degree of protection	IP20, NEMA1
	Cooling	Cooling fan is provided for 200 V, 0.75 kW (1HP) (3/single-phase) 400 V, 1.5 kW (2HP) (3-phase), others are self-cooling
	Ambient humidity	95% RH or less (without condensation)
	Storage temperature	-20 °C..+60 °C (short-term temperature during transportation)
	Installation	Indoor (no corrosive gas, dust, etc.)
	Installation height	Max. 1000 m
	Vibration	Up to 9.8 m/s ² at 10 to less than 20 Hz, Up to 6.37 m/s ² at 20 to 50 Hz

Dimensions

IP 20 type 0.1 to 4 kW

Figure 1

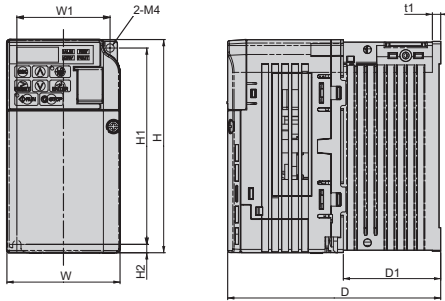
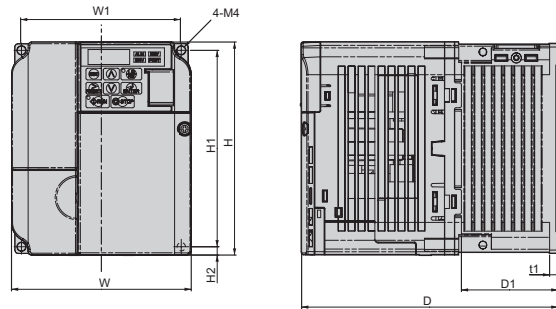
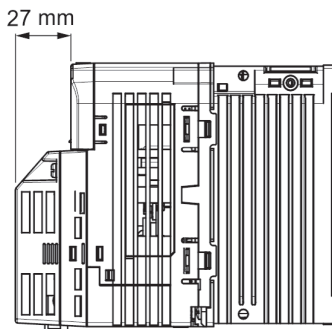

Figure 2



Voltage class	Max. applicable motor output kW	Inverter model VZA□	Figure	Dimensions in mm										Weight		
				W1	H1	W	H	D	t1	H2	D1	H3	H4			
Single-phase 200 V	0.12	B0P1	1	56	118	68	128	76	3	5	6.5	-	-	0.6		
	0.25	B0P2						108						0.7		
	0.55	B0P4						137.5						1.0		
	1.1	B0P7	2	96	108	140	154	163	180	5	5	58	-	-	1.7	
	1.5	B1P5													170	1.8
	2.2	B2P2													158	2.4
4.0	B4P0	158	170	180	180	180	180	180	180	180	65	3.0				
Three-phase 200 V	0.12	20P1	1	56	118	68	128	76	3	5	6.5	-	-	0.6		
	0.25	20P2						108						0.6		
	0.55	20P4						128						0.9		
	1.1	20P7	2	96	108	140	129	137.5	143	5	5	38.5	-	-	1.1	
	1.5	21P5													129	1.3
	2.2	22P2													137.5	1.4
	4.0	24P0	3	128	140	254	140	140	140	-	6	55	13	6.2	2.1	
	5.5	25P5													6	3.8
	7.5	27P5													8	3.8
	11	2011	3	160	284	180	290	163	163	-	8	75	15	7.2	5.5	
15	2015	7													9.2	
192	336	220													358	187
Three-phase 400 V	0.37	40P2	2	96	118	108	128	81	5	5	10	-	-	0.8		
	0.55	40P4						99						1.0		
	1.1	40P7						137.5						1.4		
	1.5	41P5	3	128	140	254	140	140	140	-	6	55	13	6	1.5	
	2.2	42P2													6	1.5
	3.0	43P0													8	1.5
	4.0	44P0	3	128	140	254	140	140	140	-	8	75	15	6	2.1	
	5.5	45P5													6	3.8
	7.5	47P5													8	3.8
	11	4011	3	160	284	180	290	143	163	-	8	75	15	6	5.2	
15	4015	8													5.5	

V1000 + Option board (Communication and 24V DC power supply)



Communication option boards

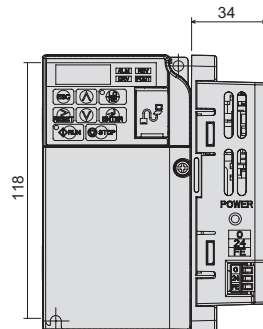

PS-V10S

24V DC Power supply Options

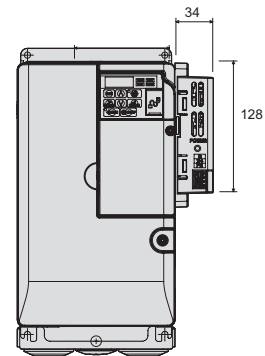

PS-V10M

Built-in Filter Dimensions

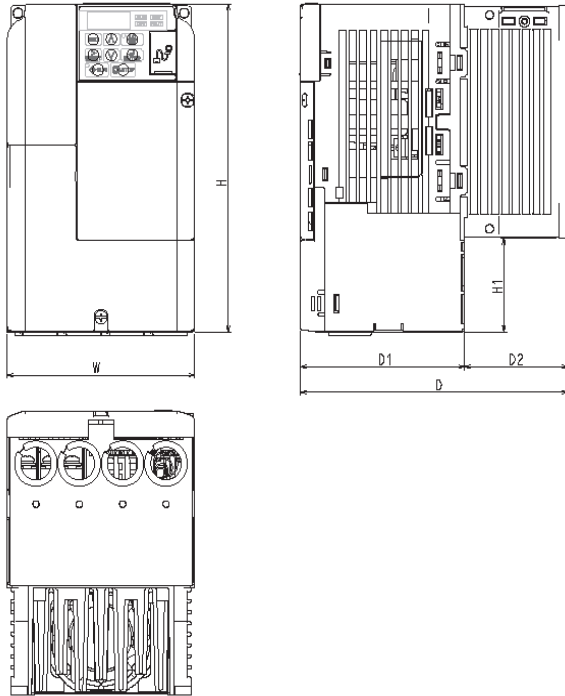

VZA□	Dimensions in mm					
	W	H	H1	D1	D2	D
B0P1	68+	178	50	69.5	6.5	76
B0P2				79.5	38.5	118
B0P4				77.9	59.6	137.5
B0P7	108			89.4	64.6	154
B1P5				96.4	66.6	163
B2P2	140	183	55	96.4	66.6	163
B4P0	Under development					
40P2	108	178	50	69.4	11.6	81
40P4				29.6	99	
40P7				77.9	59.6	137.5
41P5				94.4		
42P2				94.4	59.6	154
43P0				94.4	59.6	154
44P0	140	183	55	76.4	66.6	143
45P5	Under development					
47P5						
4011						
4015						

Schaffner footprint Filters

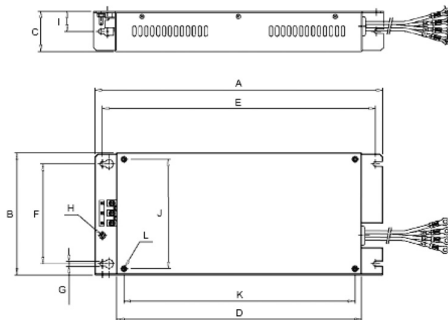

Schaffner model		Dimensions												Weight KG
		A	B	C	D	E	F	G	H	I	J	K	L	
3x200 V	A1000-FIV2010-SE	194	82	50	160	181	62	5.3	M5	25	56	118	M4	
	A1000-FIV2020-SE	169	111	50	135	156	91	5.5	M5	25	96	118	M4	
	A1000-FIV2030-SE	174	144	50	135	161	120	5.3	M5	25	128	118	M4	
	A1000-FIV2050-SE	Under development												
	A1000-FIV2080-SE	Under development												
1x200 V	A1000-FIV1010-SE	169	71	45	135	156	51	5.3	M5	22	56	118	M4	0.44
	A1000-FIV1020-SE	169	111	50	135	156	91	5.3	M5	25	96	118	M4	0.75
	A1000-FIV1030-SE	174	144	50	135	161	120	5.3	M5	25	128	118	M4	1.1
	A1000-FIV1040-SE	174	144	50	135	161	150	5	M5	25	158	118	M4	1.3
3x400 V	A1000-FIV3005-SE	169	111	45	135	156	91	5.3	M5	22	96	118	M4	0.5
	A1000-FIV3010-SE	169	111	45	135	156	91	5.3	M5	22	96	118	M4	0.7
	A1000-FIV3020-SE	174	144	50	135	161	120	5	M5	25	128	118	M4	0.9
	A1000-FIV3030-SE	304	184	56	264	288	150	6	M5	28	164	244	M5	1.8
	A1000-FIV3050-SE	340	175	65	300	325	130	6	M6	32.5	160	285	M5	2.7

Rasmi footprint Filters

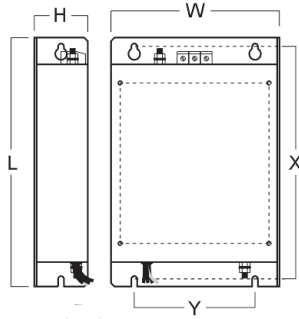

Rasmi model		Dimensions						Weight KG
		W	H	L	X	Y	M	
3x200 V	A1000-FIV2010-RE	82	50	194	181	62	M4	0.8
	A1000-FIV2020-RE	111	50	194	181	62	M4	1.1
	A1000-FIV2030-RE	144	50	174	161	120	M4	1.3
	A1000-FIV2060-RE	150	52	320	290	122	M5	2.4
	A1000-FIV2080-RE	188	62	362	330	160	M5	4.2
1x200 V	A1000-FIV2100-RE	220	62	415	380	192	M6	-
	A1000-FIV1010-RE	71	45	169	156	51	M4	0.6
	A1000-FIV1020-RE	111	50	169	156	91	M4	1.0
	A1000-FIV1030-RE	144	50	174	161	120	M4	5.3
3x400 V	A1000-FIV1040-RE	174	50	174	161	150	M4	-
	A1000-FIV3005-RE	111	45	169	156	91	M4	1.1
	A1000-FIV3010-RE	111	45	169	156	91	M4	1.1
	A1000-FIV3020-RE	144	50	174	161	120	M4	1.3
	A1000-FIV3030-RE	150	52	306	290	122	M5	2.1
A1000-FIV3050-RE	182	62	357	330	160	M5	2.9	

Remote LCD operator

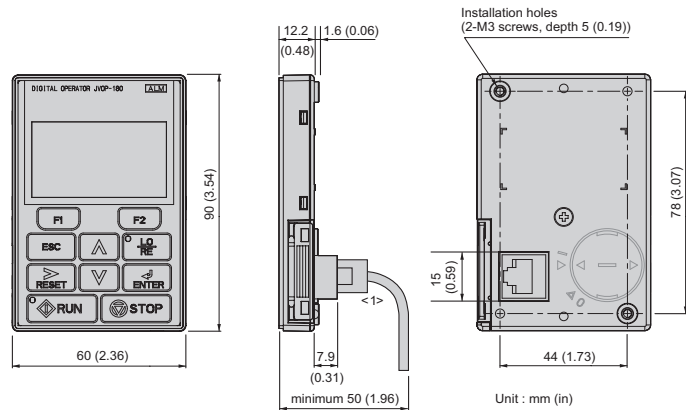

Chokes

Description	D diameter	Motor KW	Dimensions						Weight Kg
			L	W	H	X	Y	m	
A1000-FEV2102-RE	21	< 2.2	85	22	46	70	-	5	0.1
A1000-FEV2515-RE	25	< 15	105	25	62	90	-	5	0.2
A1000-FEV5045-RE	50	< 45	150	50	110	125	30	5	0.7

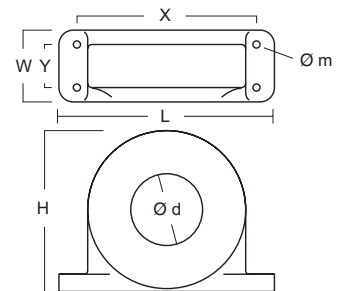

Resistor Dimensions

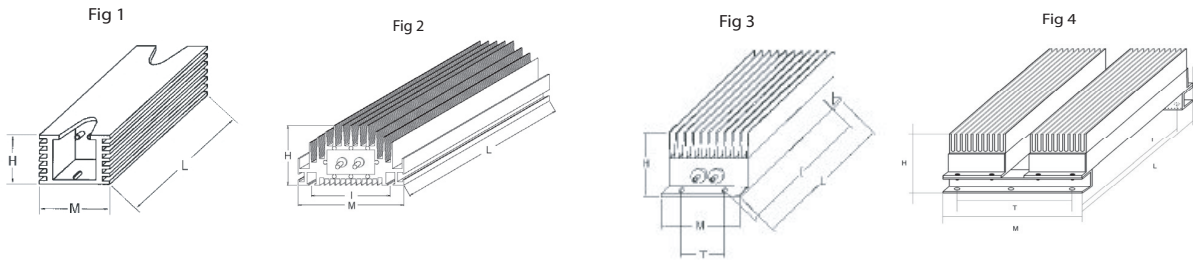

Type	Fig.	Dimensions					Weight KG
		L	H	M	I	T	
A1000-REV00K4100-IE	1	200	27	36	189	-	0.425
A1000-REV00k4020-IE					-		
A1000-REV00K4030-IE					-		
A1000-REV00k5075-IE	1	260	27	36	249	-	0.58
A1000-REV00k6050-IE	1	320	27	36	309	-	0.73
A1000-REV00K6013-IE					-		
A1000-REV00k9040-IE	2	200	62	100	74	-	1.41
A1000-REV00K9010-IE	3	365	75	100	350	70	4.7
A1000-REV02K0010-IE							
A1000-REV04k0032-IE	4	365	105	204	350	210	9,5

DIN rail mounting bracket

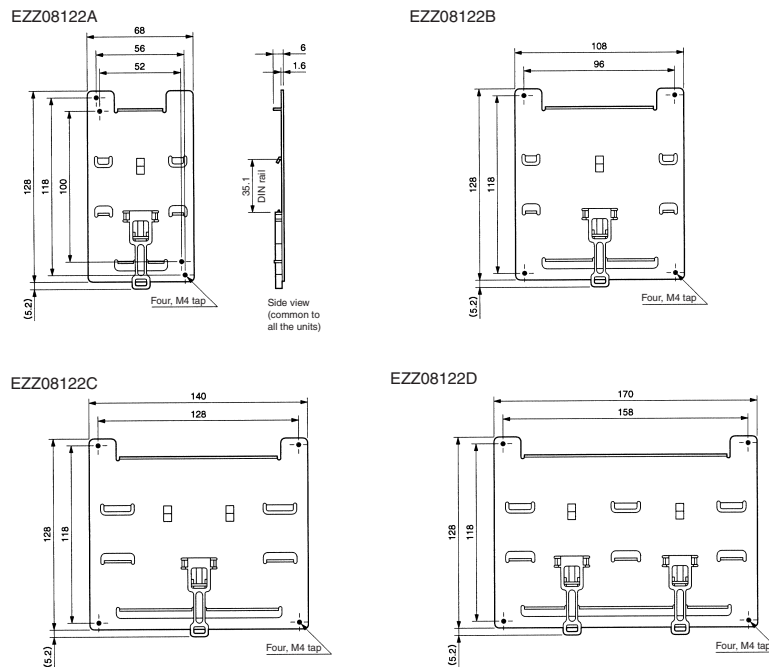

Inverter VZA□		DIN rail mounting bracket
3-phase 200 VAC	20P1/ 20P2 / 20P4/ 20P7	EZZ08122A
	21P5/ 22P2	EZZ08122B
	24P0	EZZ08122C
Single-phase 200 VAC	B0P1/ B0P2/ B0P4	EZZ08122A
	B0P7/ B1P5	EZZ08122B
	B2P2	EZZ08122C
	B4P0	EZZ08122D
3-phase 400 VAC	40P2/ 40P4/ 40P7/ 41P5/ 42P2	EZZ08122B
	44P0	EZZ08122C

Heatsink attachment and Panel cut dimensions

Heatsink External Mounting Attachment

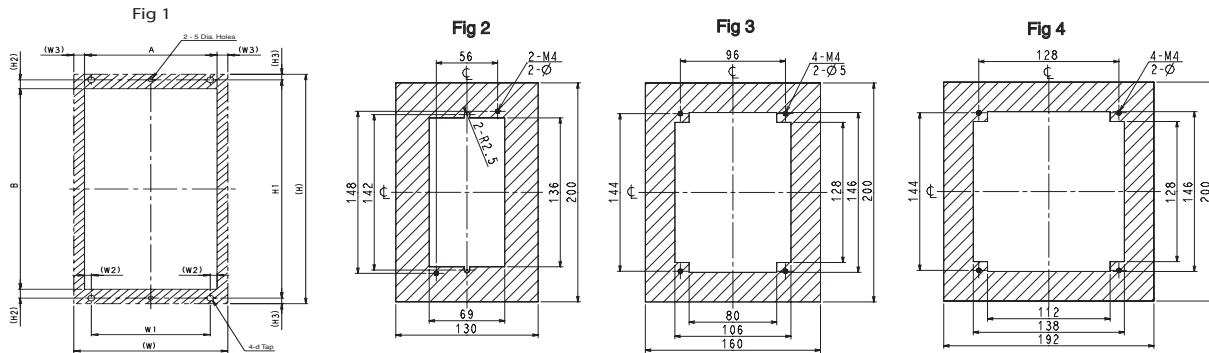
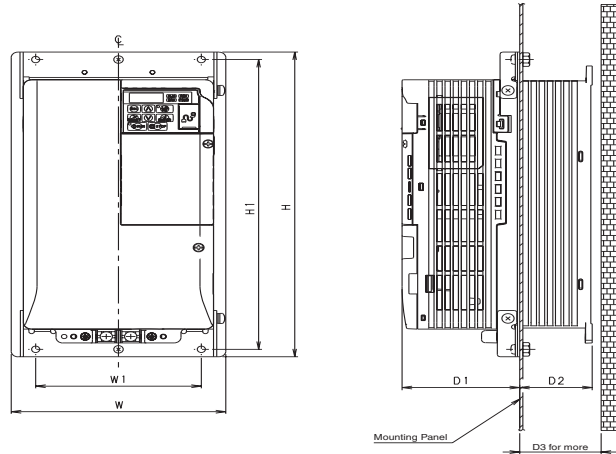

VZA□	Reference	Frame							Panel Cutting												
		W	H	W1	H1	D1	D2	D3	Fig	(W2)	(W3)	(H2)	(H3)	A	B						
3x200V	20P1	100-034-075	68	128	56	118	69.2	12	30	2	-										
	20P2							42	50												
	20P4							62	70												
	20P7	100-034-077	108	96	118	71	58	70	3	-											
	21P5	79.5																			
	22P2	86.5				53.5	60														
	24P0	100-034-080	140	128	118	86.5	53.5	60	4	-											
	25P5	100-036-300	158	286	122	272	86.6	53.4	60						1	9	9	8.5	7	140	255
	27P5															10	10.5	10.5	9	180	287
2011	100-036-301	198	322	160	308	89.6	73.4	80		14	10.5	10.5	9	220	341						
2015	100-036-302	241	380	192	362	110.6	76.4	85													
1X200V	B0P1	100-034-075	68	128	56	118	69.2	12	30	2	-										
	B0P2																				
	B0P4							79.2	42							50					
	B0P7	100-035-418	108	96	118	79.5	58	70	3	-											
	B1P5	96																			
	B2P2	100-034-080	140	128	118	98	65	70	4	-											
	B4P0	100-036-357	170	158	118	115															
Under development																					
3X400V	40P2	100-034-078	108	128	96	118	71	13.2	30	3	-										
	40P4	100-036-418					140	128	118							28	40				
	40P7															79.5	58	70			
	41P5	100-034-079	108	128	96	118	96	58	70	3	-										
	42P2																				
	43P0																				
	44P0	100-034-080	140	128	118	78	65	70	4	-											
	45P5	100-036-300	158	286	122	272	86.6	53.4	60						1	9	9	8.5	7	140	255
	47P5															10	10.5	10.5	9	180	287
	4011	100-036-301	198	322	160	308	86.6	73.4	80	1	10	9	10.5	7	180	287					
4015																					

Installation

Standard connections

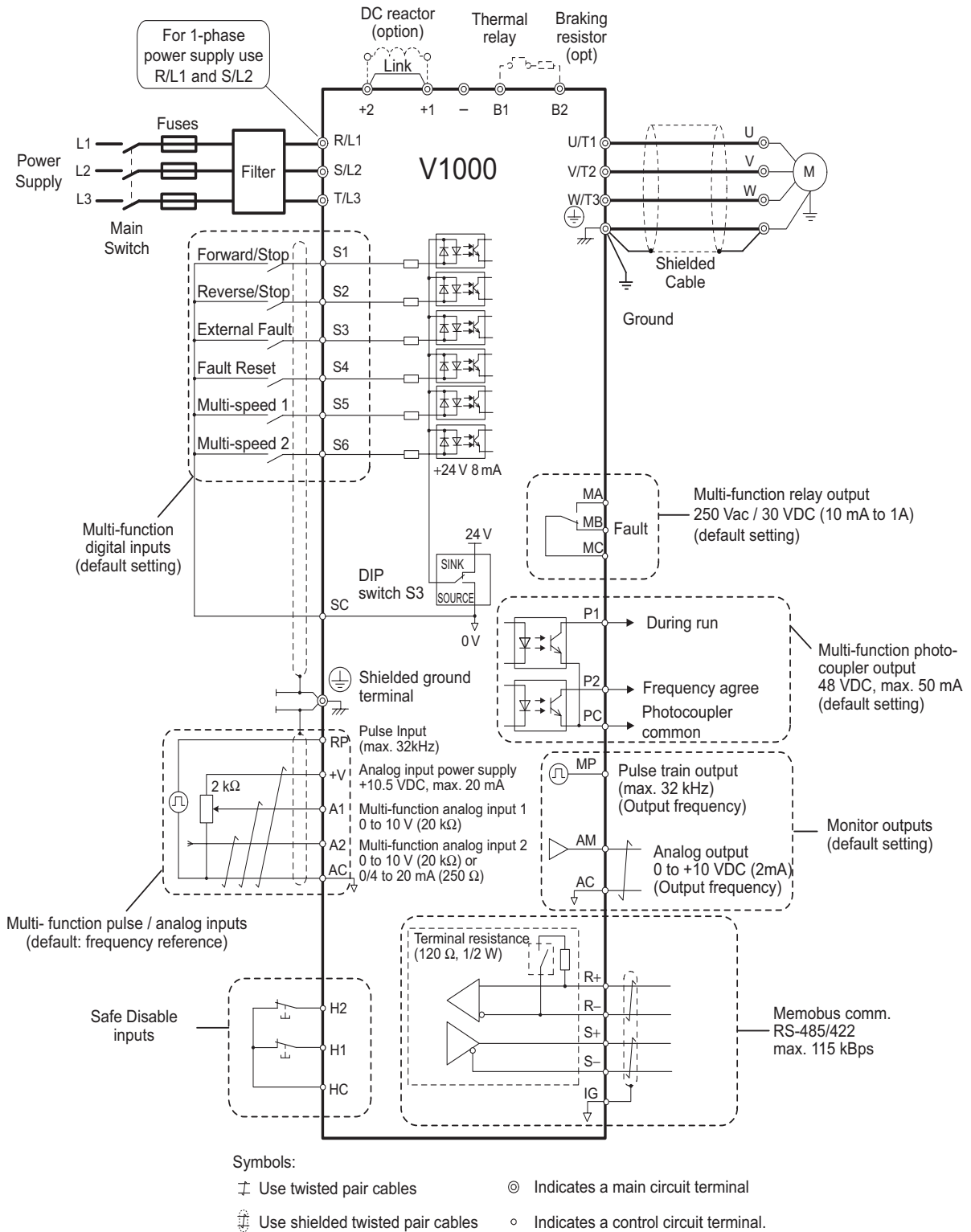

Main circuit

Terminal	Name	Function (signal level)
R/L1, S/L2, T/L3	Main circuit power supply input	Used to connect line power to the drive. Drives with single-phase 200 V input power use only terminals R/L1 and S/L2 (T/L3 is not connected to anything)
U/T1, V/T2, W/T3	Inverter output	Used to connect the motor
B1, B2	Braking resistor connection	Available for connecting a braking resistor or the braking resistor unit option.
+2, +1	DC reactor connection	Remove the short bar between +2 and +1 when connecting DC reactor (option)
+1, -	DC power supply input	For power supply input (+1: positive electrode; - : negative electrode)*
⊕	Grounding	For grounding (grounding should conform to the local grounding code.)

Control Circuit

Type	No.	Signal name	Function	Signal level
Digital input signals	S1	Multi-function input selection 1	Factory setting: runs when CLOSED, stops when OPEN.	24 VDC, 8 mA photocoupler insulation
	S2	Multi-function input selection 2	Factory setting: runs when CLOSED, stops when OPEN.	
	S3	Multi-function input selection 3	Factory setting: External Fault (N.O.)	
	S4	Multi-function input selection 4	Factory setting: Fault reset	
	S5	Multi-function input selection 5	Factory setting: Multi-step speed cmd 1	
	S6	Multi-function input selection 6	Factory setting: Multi-step speed cmd 2	
	SC	Multi-function input selection Common	Common for control signal	
Analog input signals	RP	Main Speed Cmd Pulse Train Input	32 kHz max.	
	FS	Power Supply for Frequency Setting	+10 V (allowable max current 20 mA)	
	FR1	Main Speed Freq Ref	Voltage input or current input	
	FR2		0 to +10 VDC (20 kΩ) (resolution 1/1000) 4 to 20 mA (250 Ω) or 0 to 20 mA (250 Ω) Resolution: 1/500	
	FC	Frequency reference common	0 V	
Fast Stop Cmd	HC	Power Supply Fast Stop Cmd	+24 V (max allowable current 10 mA)	
	H1	Special Digital input	Open: Fast Stop Closed: Normal Operation	
	H2	Special Digital input		
Digital output signals	MA	NO contact output	Factory setting: "fault"	Contact capacity 250 VAC, 1 A or less 30 VDC, 1 A or less
	MB	NC Output		
	MC	Relay Output common		
	P1	Photocoupler output 1	Factory setting: During run	Photocoupler output: +48 VDC, 50 mA or less
	P2	Photocoupler output 2	Factory setting: Frequency Agree	
	PC	Photocoupler output common	0 V	
Analog output signals	PM	Pulse train Output	max 33 kHz	0 to 10 V 2 mA or less Resolution: 8 bits
	AM	Analog monitor output	Factory setting: "output frequency" 0 to +10 V output Resolution: 1/1000	
	AC	Analog monitor common	0 V	
RS-485/422	R+	Communication input (+)	For MEMOBUS communication operation by RS-485 or RS-422 communication is available.	RS-485/422 MEMOBUS protocol
	R-	Communication input (-)		
	S+	Communication output (+)		
	S-	Communication output (-)		

a: Space required differs by model:
Up to 3.7 kW: minimum 30 mm
5.5 kW and above: minimum 50 mm

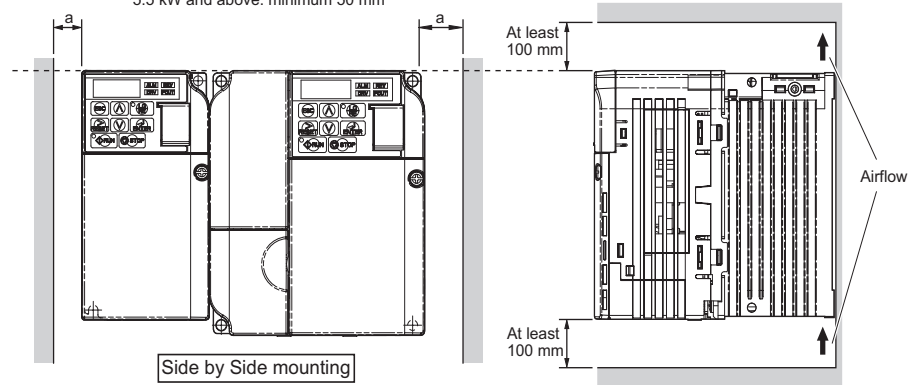

Inverter heat loss

Three-phase 200 V class

Model VZA		20P1	20P2	20P4	20P7	21P5	22P2	24P0	25P5	27P5	2011	2015
Inverter capacity kVA		0.3	0.6	1.1	1.9	3.0	4.2	6.7	9.5	13	18	23
Rated current (A) at HD		0.8	1.6	3	5	8	11	17.5	25	33	47.0	60.0
Rated current (A) at ND		1.2	1.9	3.5	6.0	9.6	12.0	19.6	30.0	40.0	56.0	69.0
Heat loss W HD	Fin	4.3	7.9	16.1	27.4	54.8	70.7	110.5	231.5	239.5	347.6	437.7
	Inside unit	7.3	8.8	11.5	15.9	23.8	30.0	43.3	72.2	81.8	117.6	151.4
	Total heat loss	11.6	16.7	27.7	43.3	78.6	100.6	153.8	303.7	321.3	465.2	589.1
Heat loss W ND	Fin	4.7	7.2	14.0	35.6	48.6	57.9	93.3	236.8	258.8	342.8	448.5
	Inside unit	7.9	9.4	13.4	16.9	25.0	29.6	45.0	87.2	11.4	149.1	182.2
	Total heat loss	12.6	16.6	28.5	43.1	73.6	87.5	138.2	324.0	370.3	491.9	630.7
Cooling Method		Self Cooled					Fan Cooled					

Single-phase 200 V class

Model VZA		B0P1	B0P2	B0P4	B0P7	B1P5	B2P2	B4P0
Inverter capacity kVA		0.3	0.6	1.1	1.9	3.0	4.2	6.7
Rated current (A) at HD		0.8	1.6	3	5	8	11	17.5
Rated current (A) at ND		1.2	1.9	3.5	6.0	9.6	12.0	-
Heat loss W HD	Fin	4.3	7.9	16.1	42.5	54.8	70.7	110.5
	Inside unit	7.4	8.9	11.5	19.0	25.9	34.1	51.4
	Total heat loss	11.7	16.7	27.7	61.5	80.7	104.8	161.9
Heat loss W ND	Fin	4.7	7.2	15.1	26.2	48.6	57.9	93.3
	Inside unit	8.4	9.6	14.3	20.8	29.0	36.3	58.5
	Total heat loss	13.1	16.8	28.3	56.5	77.6	94.2	151.8
Cooling Method		Self Cooled				Fan Cooled		

Three-phase 400 V class

Model VZA		40P2	40P4	40P7	41P5	42P2	43P0	44P0	45P5	47P5	4011	4015
Inverter capacity kVA		0.9	1.4	2.6	3.7	4.2	5.5	7.2	9.2	14.8	18	24
Rated current (A) at HD		1.2	1.8	3.4	4.8	5.5	7.2	9.2	14.8	18.0	24	31
Rated current (A) at ND		1.2	2.1	4.1	5.4	6.9	8.8	11.1	17.5	23	31	38
Heat loss W HD	Fin	19.2	28.9	42.3	70.7	81.0	84.6	107.2	166.0	207.1	266.9	319.1
	Inside unit	11.4	14.9	17.9	26.2	30.7	32.9	41.5	62.7	78.1	105.9	126.6
	Total heat loss	30.6	43.7	60.2	96.9	111.7	117.5	148.7	228.7	285.2	372.7	445.8
Heat loss W ND	Fin	8.2	15.5	26.4	37.5	49.7	55.7	71.9	170.3	199.5	268.6	298.7
	Inside unit	9.2	13.1	15.8	20.0	26.3	29.4	43.6	78.1	105.3	142.8	152.2
	Total heat loss	17.4	28.6	42.2	57.5	76.0	85.1	115.5	248.4	304.8	411.4	450.9
Cooling Method		Self Cooled					Fan Cooled					

Connections for braking resistor

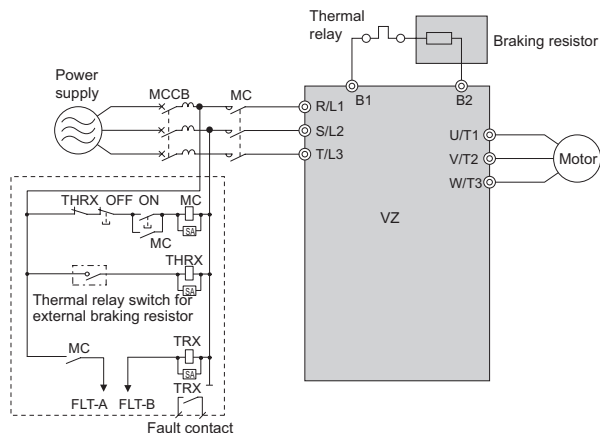

AC reactor

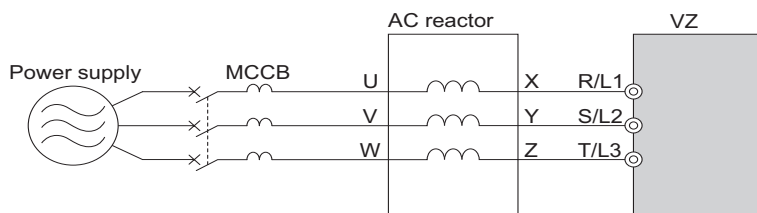

200 V class			400 V class		
Max. applicable motor output kW	Current value A	Inductance mH	Max. applicable motor output kW	Current value A	Inductance mH
0.12	2.0	2.0			
0.25	2.0	2.0			
0.55	2.5	4.2	0.2		
1.1	5	2.1	0.4	1.3	18.0
1.5	10	1.1	0.75	2.5	8.4
2.2	15	0.71	1.5	5	4.2
4.0	20	0.53	2.2	7.5	3.6
5.5	30	0.35	4.0	10	2.2
7.5	40	0.265	5.5	15	1.42
11	60	0.18	7.5	20	1.06
15	80	0.13	11	30	0.7
			15	40	0.53

DC reactor

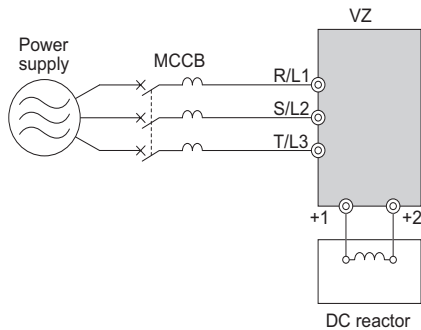

200 V class			400 V class		
Max. applicable motor output kW	Current value A	Inductance mH	Max. applicable motor output kW	Current value A	Inductance mH
0.12					
0.25					
0.55					
1.1	5.4	8	0.2		
1.5			0.4	3.2	28
2.2			0.75		
4.0	18	3	1.5	5.7	11
5.5			2.2		
7.5			4.0	12	6.3
11	36	1	5.5	23	3.6
15			7.5		
	72	0.5	11	33	1.9
			15		

Safety System

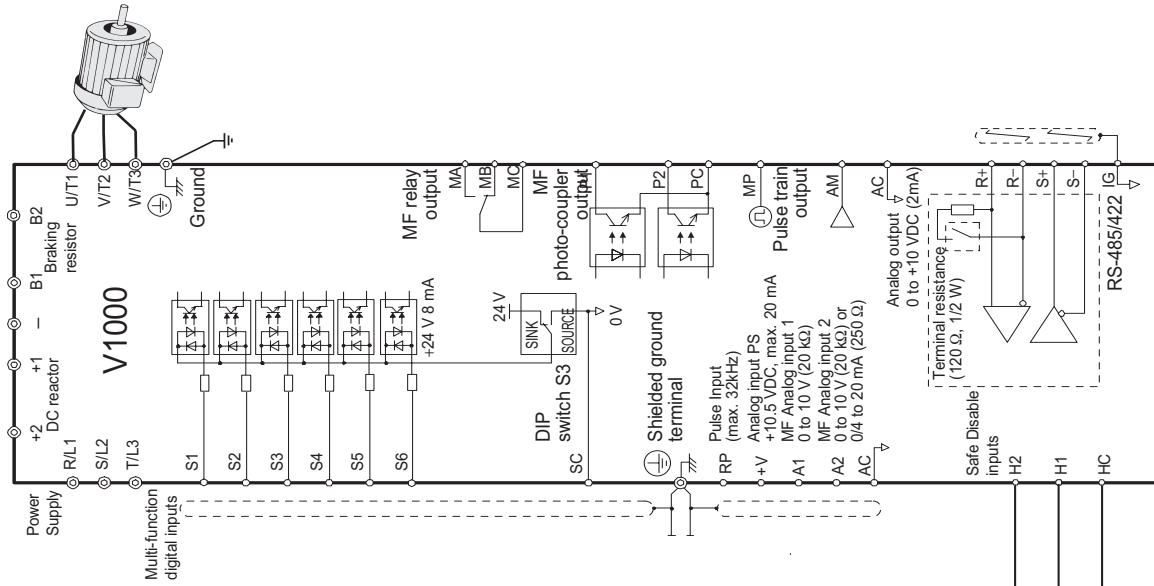

V1000 safe stop application using OMRON G9SB safety relay unit complies to safety category 3 according EN 954-1 / Stop category 0 according EN60204

Ensure V1000 and safety relay are mounted in the same cabinet to exclude cross circuit between H1 and H2

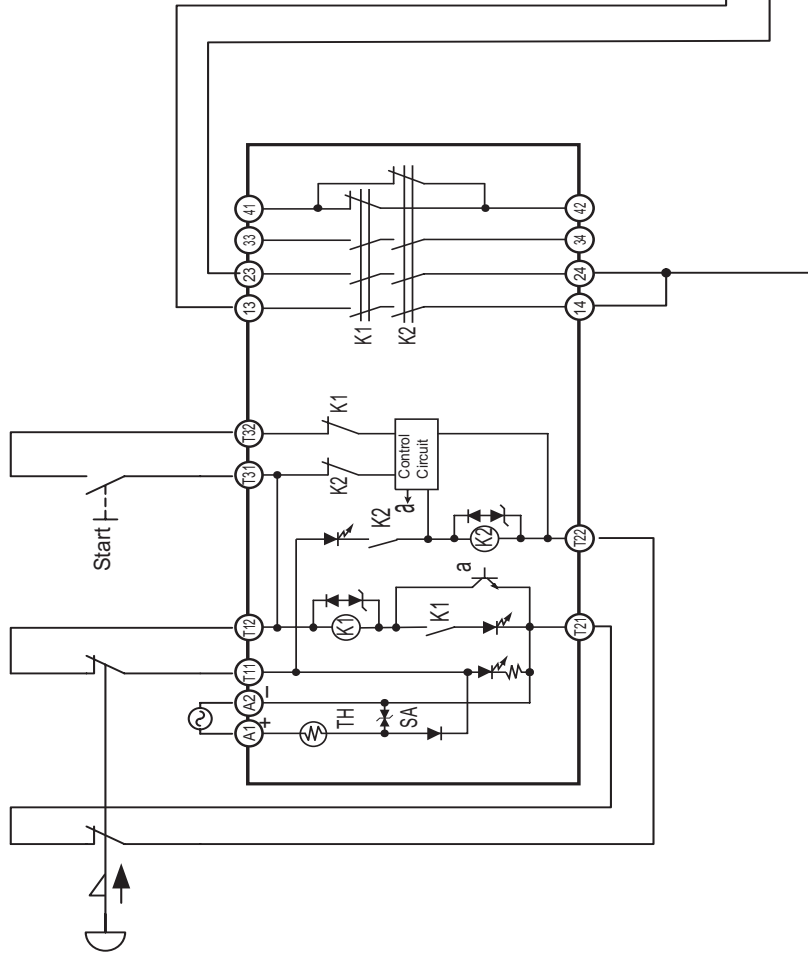

Ordering information

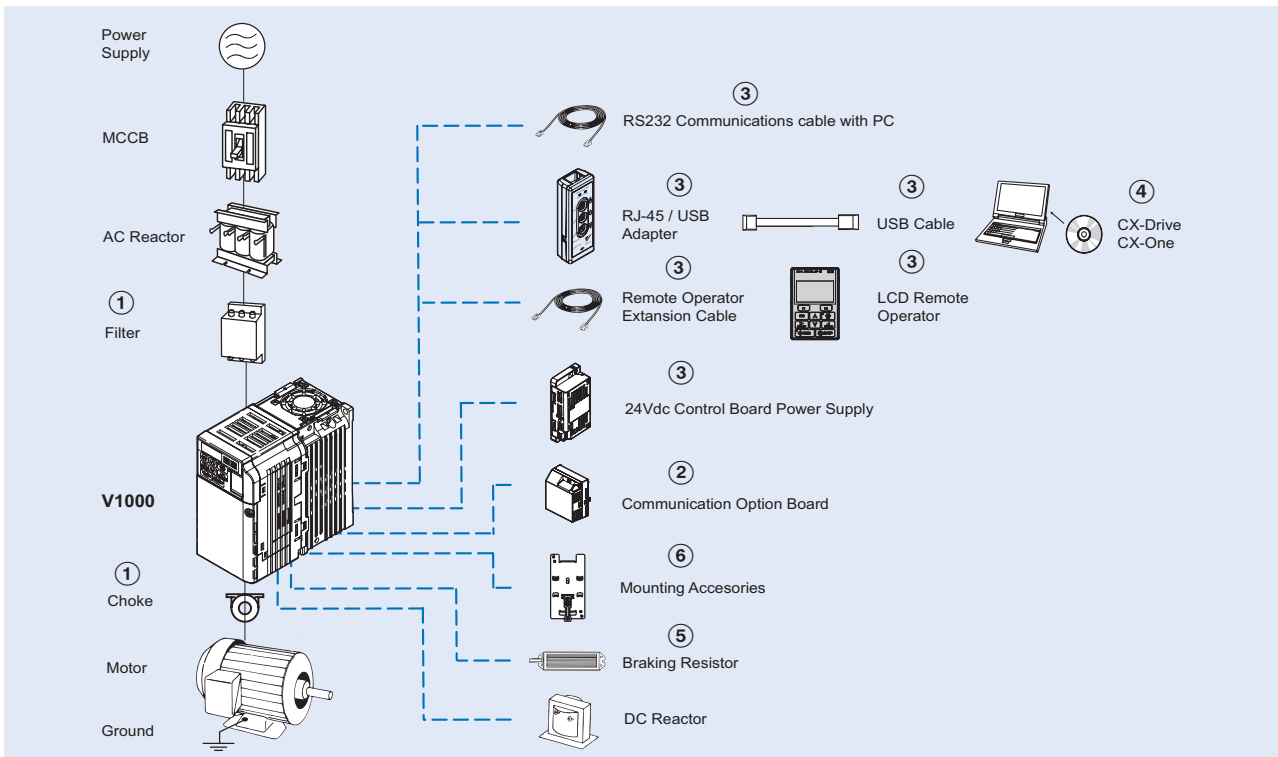

V1000

	Specifications				Model	
	Heavy Duty		Normal Duty		Standard	Built-in filter
1x200 V	0.12 kW	0.8 A	0.18 kW	0.8 A	VZAB0P1BAA	VZAB0P1EAA
	0.25 kW	1.6 A	0.37 kW	1.6 A	VZAB0P2BAA	VZAB0P2EAA
	0.55 kW	3.0 A	0.75 kW	3.5 A	VZAB0P4BAA	VZAB0P4EAA
	1.1 kW	5.0 A	1.1 kW	6.0 A	VZAB0P7BAA	VZAB0P7EAA
	1.5 kW	8.0 A	2.2 kW	9.6 A	VZAB1P5BAA	VZAB1P5EAA
	2.2 kW	11.0 A	3.0 kW	12.0 A	VZAB2P2BAA	VZAB2P2EAA
3x200 V	4.0 kW	17.5 A	5.5 kW	21.0 A	VZAB4P0BAA	VZAB4P0EAA
	0.12 kW	0.8 A	0.18 kW	0.8 A	VZA20P1BAA	VZA20P1EAA
	0.25 kW	1.6 A	0.37 kW	1.6 A	VZA20P2BAA	VZA20P2EAA
	0.55 kW	3.0 A	0.75 kW	3.5 A	VZA20P4BAA	VZA20P4EAA
	1.1 kW	5.0 A	1.1 kW	6.0 A	VZA20P7BAA	VZA20P7EAA
	1.5 kW	8.0 A	2.2 kW	9.6 A	VZA21P5BAA	VZA21P5EAA
	2.2 kW	11.0 A	3.0 kW	12.0 A	VZA22P2BAA	VZA22P2EAA
	4.0 kW	17.5 A	5.5 kW	21.0 A	VZA24P0BAA	VZA24P0EAA
	5.5 kW	25.0 A	7.5 kW	30.0 A	VZA25P5FAA	VZA25P5EAA
	7.5 kW	33.0 A	11.0 kW	40.0 A	VZA27P5FAA	VZA27P5EAA
3x400 V	11 kW	47.0 A	15.0 kW	56.0 A	VZA2011FAA	VZA2011EAA
	15 kW	60.0 A	18.5 kW	69.0 A	VZA2015FAA	VZA2015EAA
	0.37 kW	1.2 A	0.37 kW	1.2 A	VZA40P2BAA	VZA40P2EAA
	0.55 kW	1.8 A	0.75 kW	2.1 A	VZA40P4BAA	VZA40P4EAA
	1.1 kW	3.4 A	1.5 kW	4.1 A	VZA40P7BAA	VZA40P7EAA
	1.5 kW	4.8 A	2.2 kW	5.4 A	VZA41P5BAA	VZA41P5EAA
	2.2 kW	5.5 A	3.0 kW	6.9 A	VZA42P2BAA	VZA42P2EAA
	3.0 kW	7.2 A	4.0 kW	8.8 A	VZA43P0BAA	VZA43P0EAA
	4.0 kW	9.2 A	5.5 kW	11.1 A	VZA44P0BAA	VZA44P0EAA
	5.5 kW	14.8 A	7.5 kW	17.5 A	VZA45P5FAA	VZA45P5EAA
7.5 kW	18.0 A	11.0 kW	23.0 A	VZA47P5FAA	VZA47P5EAA	
11 kW	24.0 A	15.0 kW	31.0 A	VZA4011FAA	VZA4011EAA	
15 kW	31.0 A	18.5 kW	38.0 A	VZA4015FAA	VZA4015EAA	

① Line filters

Voltage	Inverter		Line filter Schaffner			Line filter Rasmi		
	Model VZA□	Reference	Rated current (A)	Weight (kg)	Reference	Rated current (A)	Weight (kg)	
3-Phase 200 VAC	20P1 / 20P2 / 20P4 / 20P7	A1000-FIV2010-SE	10	0.7	A1000-FIV2010-RE	10	0.8	
	21P5 / 22P2	A1000-FIV2020-SE	20	0.9	A1000-FIV2020-RE	20	1.1	
	24P0	A1000-FIV2030-SE	30	1.0	A1000-FIV2030-RE	30	1.3	
	25P5 / 27P5	A1000-FIV2050-SE	Under development		A1000-FIV2060-RE	58	2.4	
	2011	A1000-FIV2080-SE			A1000-FIV2080-RE	80	-	
2015	A1000-FIV2100-SE	A1000-FIV2100-RE			100	4.2		
Single-Phase 200 VAC	B0P1 / B0P2 / B0P4	A1000-FIV1010-SE	10	0.5	A1000-FIV1010-RE	10	0.6	
	B0P7 / B1P5	A1000-FIV1020-SE	20	0.7	A1000-FIV1020-RE	20	1.0	
	B2P2	A1000-FIV1030-SE	30	1.0	A1000-FIV1030-RE	30	1.1	
	B4P0	A1000-FIV1040-SE	40	1.1	A1000-FIV1040-RE	40	-	
3-Phase 400 VAC	40P2 / 40P4	A1000-FIV3005-SE	5	0.5	A1000-FIV3005-RE	5	1.1	
	40P7 / 41P5 / 42P2 / 43P0	A1000-FIV3010-SE	10	0.75	A1000-FIV3010-RE	10	1.1	
	44P0	A1000-FIV3020-SE	15	1.0	A1000-FIV3020-RE	20	1.3	
	45P5 / 47P5	A1000-FIV3030-SE	Under development		A1000-FIV3030-RE	29	2.1	
	4011 / 4015	A1000-FIV3050-SE			A1000-FIV3050-RE	48	2.9	

Chokes

Model	Diameter	Description
A1000-FEV2102-RE	21	Recommended for motors below 2.2 KW
A1000-FEV2515-RE	25	Recommended for motors below 15 KW
A1000-FEV5045-RE	50	Recommended for motors below 45 KW

② Communication cards

Type	Model	Description	Function
Communication option board	SI-N3/V-OY	DeviceNet option card	• Used for running or stopping the inverter, setting or referencing parameters, and monitoring output frequency, output current, or similar items through DeviceNet communication with the host controller.
	SI-P3/V-OY	PROFIBUS-DP option card	• Used for running or stopping the inverter, setting or referencing parameters, and monitoring output frequency, output current, or similar items through PROFIBUS-DP communication with the host controller.
	SI-S3/V-OY	Can open option card	• Used for running or stopping the inverter, setting or referencing parameters, and monitoring output frequency, output current, or similar items through CANopen communication with the host controller.
	SI-T3/V-OY	Mechatrolink II option card	• Used for running or stopping the inverter, setting or referencing parameters, and monitoring output frequency, output current, or similar items through Mechatrolink II communication with the host controller.

③ Accessories

Types	Model	Description	Functions
Digital operator	JVOP-180	LCD remote operator	LCD Display operator with language support
	A1000-CAVOP300-EE	Remote operator cable	3 meters cable for connecting remote operator
Accessories	JVOP-181	USB converter / USB cable	USB converter unit with copy and backup function
	PS-V10S	24 VDC option board	24V DC control board power supply VZA-B/2/4 from 0.1 to 4 KW
	PS-V10M		24V DC control board power supply VZA-2/4 from 5.5 to 15 KW
	A1000-CAVPC232-EE	PC connection cable	RS232 PC tool connection cable

④ Computer software

Types	Model	Description	Installation
Software	CX-drive	Computer software	Configuration and monitoring software tool
	CX-One	Computer software	Configuration and monitoring software tool

⑤ Braking unit, braking resistor unit

Voltage	Inverter				Braking resistor unit			
	Max. applicable motor output kW	Inverter model VZA□		Connectable min. resistance Ω	Inverter-mounted type (3 %ED, 10 sec max)			
		3-phase	1-phase		Type	Resistance Ω	No. of used	Braking torque %
200 V (single-/three-phase)	0.12	20P1	B0P1	300	ERF-150WJ401	400	1	220
	0.25	20P2	B0P2	300	ERF-150WJ401	400	1	220
	0.55	20P4	B0P4	200	ERF-150WJ201	200	1	220
	1.1	20P7	B0P7	120	ERF-150WJ201	200	1	125
	1.5	21P5	B1P5	60	ERF-150WJ101	100	1	125
	2.2	22P2	B2P2	60	ERF-150WJ700	70	1	120
	4.0	24P0	B4P0	32	ERF-150WJ620	62	1	100
	5.5	25P5	-	16	A1000-REV00K4030-IE	30	1	-
	7.5	27P5	-	9.6	A1000-REV00K4020-IE	20	1	-
400 V (three-phase)	0.37	40P2	-	750	ERF-150WJ751	750	1	230
	0.55	40P4	-	750	ERF-150WJ751	750	1	230
	1.1	40P7	-	510	ERF-150WJ751	750	1	130
	1.5	41P5	-	240	ERF-150WJ401	400	1	125
	2.2	42P2	-	200	ERF-150WJ301	300	1	115
	3.0	43P0	-	100	ERF-150WJ401	400	2	105
	4.0	44P0	-					
	5.5	45P5	-	32	A1000-REV00k4100-IE	100	1	-
	7.5	47P5	-	32	A1000-REV00k5075-IE	75	1	-
	11	4011	-	20	A1000-REV00k6050-IE	50	1	-
	15	4015	-	20	A1000-REV00k9040-IE	40	1	-
					A1000-REV04K0032-IE	32	1	-

⑥ Mounting accessories

Types	Model	Description	Applicable models VZA□
DIN Rail	EZZ08122A	Necessary to mount the inverter on a DIN rail	20P1/20P2/20P4/20P7 B0P1/B0P2/B0P4
	EZZ08122B		21P5/22P2 B0P7/B1P5 40P2/40P4/40P7/41P5/42P2
	EZZ08122C		24P0 B2P2 44P0
	EZZ08122D		B4P0
Heatsink external mounting attachment	100-034-075	Additional items to mount the inverter with the heat-sink out of the panel.	20P1/20P2 B0P1/B0P2
	100-034-076		20P4 B0P4
	100-034-077		20P7
	100-034-078		40P2
	100-034-079		21P5/22P2 B1P5 41P5/42P2/43P0
	100-034-080		24P0 B2P2 44P0
	100-036-357		B4P0
	100-036-418		B0P7 40P2/40P4
	100-036-300		25P5/27P5 45P5/47P5
	100-036-301		2011 4011/4015
	100-036-302		2015

ALL DIMENSIONS SHOWN ARE IN MILLIMETERS.
To convert millimeters into inches, multiply by 0.03937. To convert grams into ounces, multiply by 0.03527.