

# Spur Gearhead GS 24 A Ø24 mm, 0.1 Nm

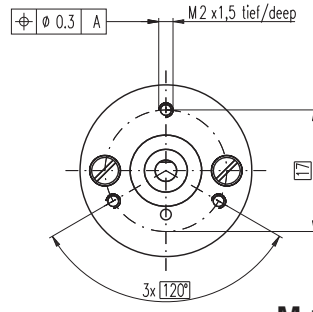
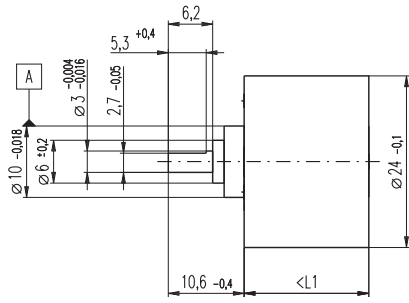

M 1:1

## Technical Data

Spur Gearhead	straight teeth
Housing	plastic
Output shaft	stainless steel, hardened
Bearing at output	sleeve bearing
Radial play, 8 mm from flange	max. 0.038 mm
Axial play	0.03 - 0.30 mm
Max. radial load, 8 mm from flange	5 N
Max. permissible axial load	8 N
Max. permissible force for press fits	500 N
Recommended input speed	< 4000 rpm
Recommended temperature range	-20 ... +100°C
Extended area as option	-35 ... +100°C

- Stock program
- Standard program
- Special program (on request)

## Order Number

	110480	110481	110482	110483	110484	110485	110486
<b>Gearhead Data</b>							
1 Reduction	7.2 : 1	20 : 1	32 : 1	64 : 1	131 : 1	199 : 1	325 : 1
2 Reduction absolute	$\frac{93}{13}$	$\frac{121915}{6153}$	$\frac{151813}{4695}$	$\frac{837}{13}$	$\frac{212629}{1625}$	$\frac{778642}{3909}$	$\frac{1093365}{3362}$
3 Max. motor shaft diameter mm	2	2	2	2	2	2	2
4 Number of stages	2	4	4	4	4	6	6
5 Max. continuous torque Nm	0.1	0.1	0.1	0.1	0.1	0.1	0.1
6 Intermittently permissible torque at gear output Nm	0.15	0.15	0.15	0.15	0.15	0.15	0.15
7 Sense of rotation, drive to output	=	=	=	=	=	=	=
8 Max. efficiency %	81	66	66	66	66	53	53
9 Weight g	25	28	28	28	28	30	30
10 Average backlash no load °	1.0	2.0	2.0	2.0	2.0	3.0	3.0
11 Mass inertia gcm <sup>2</sup>	0.008	0.01	0.008	0.007	0.006	0.008	0.006
12 Gearhead length L1* mm	13.7	17.4	17.4	17.4	17.4	21.2	21.2

\*for A-max 19 L1 is + 2.8 mm



## maxon Modular System

+ Motor	Page	+ Sensor / Brake	Page	Overall length [mm] = Motor length + gearhead length + (sensor / brake) + assembly parts						
A-max 19	97/98			45.5	49.2	49.2	49.2	49.2	53.0	53.0
A-max 19, 1.5 W	98	MR	260/262	50.6	54.3	54.3	54.3	54.3	58.1	58.1
A-max 19, 1.5 W	98	Enc 22	267	59.9	63.6	63.6	63.6	63.6	67.4	67.4
A-max 19, 1.5 W	98	MEnc 13	275	53.0	56.7	56.7	56.7	56.7	60.5	60.5
A-max 19, 2.5 W	99/100			48.1	51.8	51.8	51.8	51.8	55.6	55.6
A-max 19, 2.5 W	100	MR	260/262	52.4	56.1	56.1	56.1	56.1	59.9	59.9
A-max 19, 2.5 W	100	Enc 22	267	62.5	66.2	66.2	66.2	66.2	70.0	70.0
A-max 19, 2.5 W	100	MEnc 13	275	55.6	59.3	59.3	59.3	59.3	63.1	63.1
A-max 22	101-104			45.7	49.4	49.4	49.4	49.4	53.2	53.2
A-max 22	102/104	MR	260/262	50.7	54.4	54.4	54.4	54.4	58.2	58.2
A-max 22	102/104	Enc 22	267	60.1	63.8	63.8	63.8	63.8	67.6	67.6
A-max 22	102/104	MEnc 13	275	52.8	56.5	56.5	56.5	56.5	60.3	60.3