

### 1. Overview

MRK Safety Interlock Switches are designed to conform with the European standards for the "Safety of Machinery" which have been derived from the European Directives 89/392/EEC, 91/368/EEC and 93/44/EEC. BSI Testing have type tested the Safety Interlock Switches to show conformity with the Supply of Machinery (Safety) Regulation 1994 (SI 2063). The standards used for these tests were: BS 3955 1986, BS 5304 1988 and BS EN 1088.

### 2. Principles of operation and use

MRK Safety Interlock Switches provide safe interlocking of fixed and moveable guards, access panels and doors etc. These devices are very tolerant to misalignment and are particularly suited to environments that are contaminated by solids, dust or liquid and where non contact interlocking is required.

MRK Safety Interlock Switch consists of two parts, the switch housing with a connection cable and the magnetic actuator. The Interlock contact operates (closes) when the actuator is in close proximity to the switch housing, see figure 1. An auxiliary contact that works in the opposite mode is provided to enable automatic monitoring. The auxiliary contact is not fused. The operating distances shown in table 1 apply to situations where the switch and actuator are not mounted on, or near to ferrous surfaces. When mounted on or near ferrous surfaces the operating distance will be reduced. Avoid close proximity to strong magnetic fields i.e. electric motors and solenoids.

The switch can be operated through a non ferrous skin such as non magnetic stainless steel, plastic, aluminium and non ferrous castings etc. possibly enabling the switch and its connections to be inside part of the machine.

It should be noted that the Interlock Switch function is to provide safe interlocking as detailed above, the device should not be used or relied on as an emergency stop control.

To aid selection, listed in table 1 are the various Safety Interlock Switch types. The suitability for any safety related device must be confirmed by a risk assessment for each application.

### 3. Loads

If inductive loads are to be switched the Interlock switch contacts must be protected either with a reverse polarity diode across the inductive load, a suitable CR network or a varistor. If the load is of a capacitive nature i.e. more than a 25 metre cable run, then a suitable CR network should be used. To ensure maximum contact life and reliability, ensure that the maximum load ratings are not exceeded. For technical advice on specific loads, contact our technical department.

### 4. Fitting and adjustment

When considering a fixing position refer to "Principles of operation and use", also consider the placement of the Interlock Switch with a view to making it difficult to defeat the switch, see BS EN 1088.

Ensure that the vibration limits will not be exceeded both in normal and in any foreseen abnormal operation. If vibration is a problem the switch unit may be mounted on a rubber block (at least 87 L x 23 W x 8 D mm) to reduce the affects of vibration.

The switch and actuator should not be fixed so that they slide longitudinally against each other, as multiple operation may occur.

The Safety Interlock Switches **must** be fitted with appropriate security screws (M4 x 20 mm minimum) to avoid unauthorised personnel adjusting or removing them. The security screw driver should be kept by a person authorised to maintain the switches. Suitable security screws and drivers are available from RS Components Ltd, RS Part number 279-414.

When adjusting the MRK Interlock Switch for maximum operation distance it is recommended that the switch is magnetically overdriven by at least 25% i.e. With an application that gives a maximum operating distance of 16 mm it should be considered that the maximum distance is actually 16 mm less 25% = 12 mm, therefore to operate the switch correctly the actuator magnet should be within 12 mm of the switch.

Consideration should be given to the safe routing of the connecting cable, avoid cable runs where mechanical damage to the cable may occur, if this is likely a Copex gland may be fitted so that the cable may be routed in conduit - only on cable versions. BH versions use Brad Harrison connectors. Ensure that the electrical connections are made as in the table 2, check that the contact ratings are not exceeded, table 1. As the Interlock switch contacts are protected by a non reset fuse it is recommended that these contacts are externally fused at 75% of the internal fuse value. Use HBC quick blow fuses.

Ensure that any spare actuators are removed from the installation site and are held only by authorised personnel and not the machine operators, also remove any magnetic material that might insight an operator to try and defeat the Interlock Switch.

### 5. Maintenance

Ensure that the machine is in a safe condition before any maintenance is carried out, refer to the machine's instructions on how to achieve this.

The Interlock Switch should be routinely checked to verify its continued operation, the frequency of these checks must be decided by the manufacturer of the machine, although it is recommended that these checks are carried out at least monthly.

The switch and actuator may be cleaned if required using warm water and detergent, if removal of the Interlock Switch is required follow "4. Fitting and adjustment" for re fitting.

Examine the connecting cable for wear and tear and replace the switch if the cable is damaged.

### Order Codes

Type	Description
MRK-11	1 n/o + 1 n/c contact c/w MRK-AM
MRK-12	2 n/o + 1 n/c contact c/w MRK-AM
MRK-11BH	1 n/o + 1 n/c contact c/w MRK-AM – Brad Harrison connector
MRK-12BH	2 n/o + 1 n/c contact c/w MRK-AM – Brad Harrison connector
MRK-AM	Spare actuator for above

Table 1	Interlock Switch Specifications	
	MRK-11 / BH	MRK-12 / BH
Interlock contacts	1 normally open	2 normally open
Interlock contact maximum ratings	1A resistive	0.1A inductive
	100V dc 50VA	
Internal fuse(s) rating	1.5A	
Auxiliary contacts	1 normally closed	
Auxiliary contact maximum ratings	1A resistive, 0.1A inductive	
	100V dc, 50VA	
Electrical life	200,000 operations	
Mechanical life	10 <sup>7</sup>	
Maximum vibration	50-2000 Hz = 15g	
Maximum shock	11ms ½ sine = 10g	
Operating temp	-10 to +55°C	
Housing IP rating	Red Polycarbonate - Sealed to IP67	
Connector BH version	M12, 4 Pole	½ inch UNF 6 Pole
*Connecting cable	3 metre 4 core	3 metre 6 core
Operating (front) distance (side)	18mm	9mm
Dropout differential	12mm	
Misalignment tolerance	+ or - 10mm	
Operate time, 1 metre per second approach	21ms	
Release time, 1 metre per second removal	23ms	

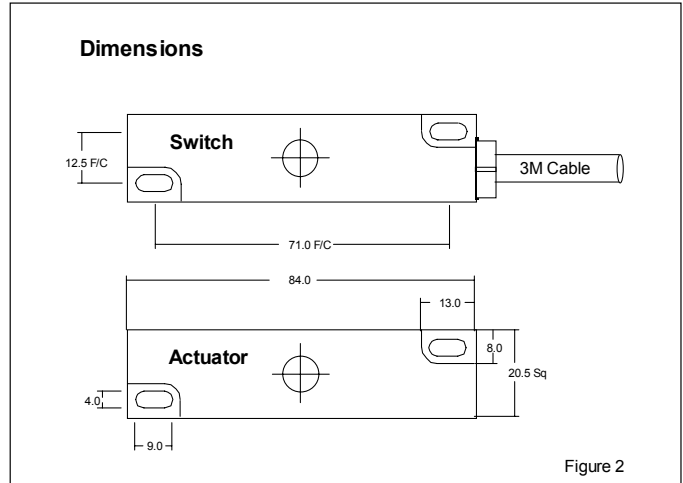

Figure 2

Table 2	Connections		
Device/Contact	Interlock Contact 1	Interlock Contact 2	Auxiliary Contact
MRK-11	Red & Blue	-	Green & Yellow
MRK-11BH	Brown & Blue	-	White & Black
MRK-12	Red & Blue	White & Black	Green & Yellow
MRK-12BH	Red/Black & Red/White	Red/Blue & Red	Red/Yellow & Green

## Operating Positions

Operating relationship between the switch and actuator

Figure 1

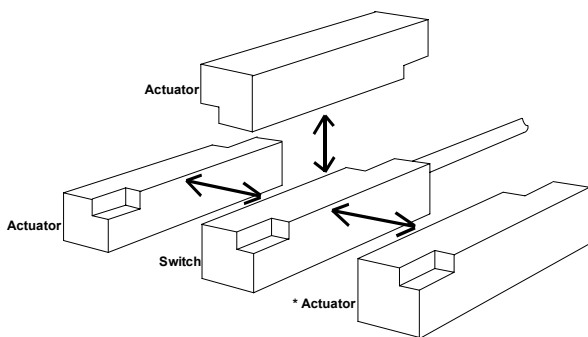

## Schematic Circuit

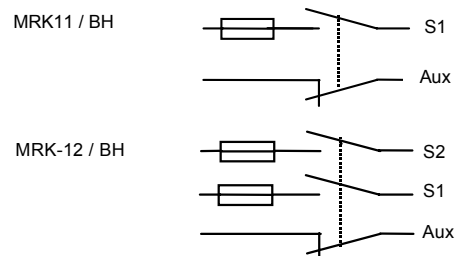

Figure 3

## Brad Harrison Connector Version

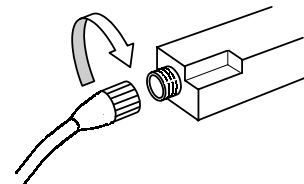

Figure 4