

F3SN-A/F3SN-B/F3SH-A

- Lineup includes Type-4 Sensors (F3SN-A/F3SH-A) and Type-2 Sensors (F3SN-B) with IEC, EN, and JIS standard certification.

EC Machine Directive compliance (from DEMKO).

USA UL compliance for applications for the USA or Canada.

- Protective height equals the Sensor length to perfectly meet user needs.
- Protective height: 189 to 1,822 mm
Operating range: 7 or 10 m
- Setting Console enabling setting parameters for any model.
- LED bar for beam alignment or easy confirmation in error mode.
- A complete lineup of accessories.



Be sure to read the "Safety Precautions" on page 28 and the "Precautions for All Safety Sensors".

Features

Two Forms of Safety from OMRON: Safety Light Curtains and Multibeam Safety Sensors

Safety Light Curtains for Finger Protection

F3SN-A□□□□P14

- Operating range: 7 m
- Smallest detectable object:
14 mm dia. (beam gap: 9 mm)
- Protective height: 189 to 1,125 mm

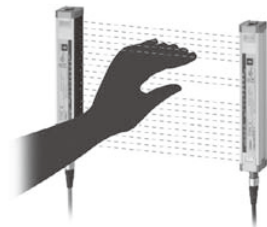

Safety Light Curtains for Hand Protection

F3SN-A□□□□P25

F3SN-B□□□□P25

- Operating range: 10 m
- Smallest detectable object:
25 mm dia. (beam gap: 15 mm)
- Protective height: 217 to 1,822 mm

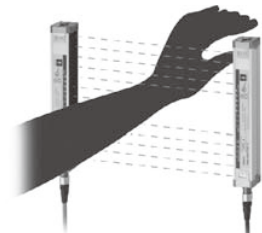

Presence Detection in Danger Zones (Horizontal Installation)

F3SN-A□□□□P40/P70

F3SN-B□□□□P40/P70

- Operating range: 10 m
- Smallest detectable object: 40 mm dia. (beam gap: 30 mm) or
70 mm dia. (beam gap: 60 mm)
- Protective height:
F3SN-A: 217 to 1,822 mm
F3SN-B: 217 to 1,777 mm



Multi-beam Safety Sensor for Body Protection

F3SN-A09P03

- Operating range: 10 m
- Number of beams: 4 (beam gap: 300 mm)



A New Concept to Meet User Needs

Connect Up To Three Sets in Series without Mutual Interference

Combine Standard Models with Linking Models with Connectors to connect up to three sets in series. Wiring is required only for one set instead of wiring all three sets, as would have been required previously, to enable protecting all sides of hazardous areas. Mutual interference protection is also provided.



Note: Use models with the following model number suffixes for series connection: -01, -03, -04, and -05

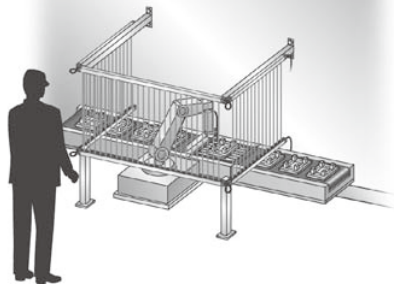

Many Connector Variations

Select the type of connector that best suits the machine. (Consult your OMRON representative.)

Standard: No model No. suffix	Model No. suffix: -01	Model No. suffix: -02	Model No. suffix: -03	Model No. suffix: -04	Model No. suffix: -05

Various Safety Functions Built into the Sensor. Supports Many Safety Circuit Configurations

- Interlocks
- Auto-reset or manual reset
- External relay monitoring

Select the Safety Circuits for the Required Safety Standards

Build Circuits for Type 4 (F3SN-A/F3SH-A) or Type 2 (F3SN-B) with No Relay Units (2 Relays with Forcibly Guided Contacts)

- Reduced Costs and Reduced Space Requirements

A built-in external relay monitor function eliminates the need for Safety Relay Units.

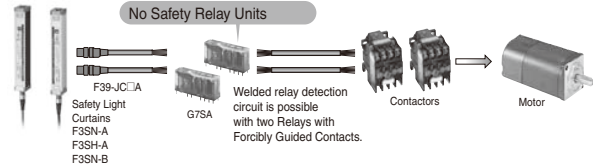

- Reduced Wiring and Easy Maintenance

One-touch connection with connectors on both end to prevent wiring mistakes.

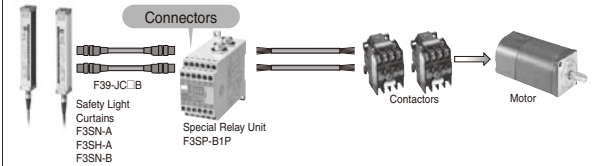

LED Bars for Easier Application

Align Beams with the LED Bar for Easier Installation

- Beam Alignment Indicators (Green Only)

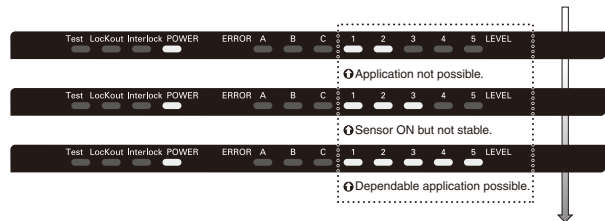

Easily Discern Error Mode Displays to Back Up Safety

- Error Indication Example (Red Only)

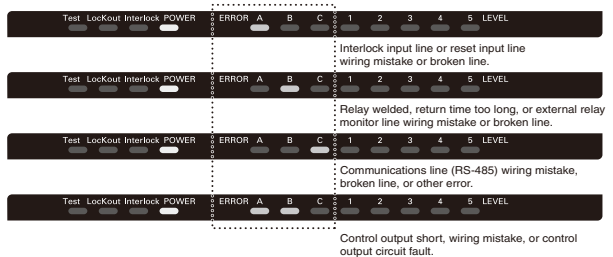
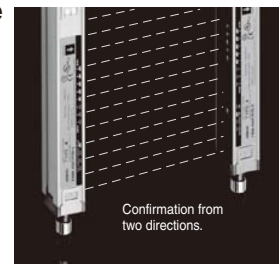

Ordering Information

Main Units (Connecting Cables are not included with the Main Units. The connecting cables must be purchased separately.)

F3SN-A Safety Light Curtains (Type 4)

Infrared

Detection capability	Beam gap	Appearance	Operating range	Number of beams	Protective height	Connector for series-connection	Model *1 *2
14 mm-dia. (for finger protection)	9 mm			21 to 125 (odd numbers only)	189 to 1125 mm (every 18 mm)	No	F3SN-A□□□□P14
						Yes	F3SN-A□□□□P14-01
25 mm-dia. (for hand protection)	15 mm		13 to 120	217 to 1822 mm (every 15 mm)	No	F3SN-A□□□□P25	
					Yes	F3SN-A□□□□P25-01	
40 mm-dia. (for presence protection)	30 mm		7 to 60	217 to 1807 mm	No	F3SN-A□□□□P40	
					Yes	F3SN-A□□□□P40-01	
70 mm-dia. (for presence detection)	60 mm		5 to 30	277 to 1777 mm	No	F3SN-A□□□□P70	
					Yes	F3SN-A□□□□P70-01	

*1. The □□□□ in the model numbers indicates the protective height (in mm). Refer to "Safety Light Curtain Model List" on page 4 for model number details.

*2. Safety Light Curtains with model numbers ending in -02 through -05, provided with different connector configurations, are also available as options. Consult with your dealer or OMRON representative when ordering these models.

F3SN-B Safety Light Curtains (Type 2)

Infrared

Detection capability	Beam gap	Appearance	Operating range	Number of beams	Protective height	Output *1	Connector for series-connection	Model *2 *3
25 mm-dia. (for hand protection)	15 mm			13 to 119 (non-continuous)	217 to 1807 mm	PNP transistor output	No	F3SN-B□□□□P25
							Yes	F3SN-B□□□□P25-01
40 mm-dia. (for presence detection)	30 mm			7 to 60 (non-continuous)	217 to 1807 mm		No	F3SN-B□□□□P40
							Yes	F3SN-B□□□□P40-01
70 mm-dia. (for presence detection)	60 mm			5 to 30	277 to 1777 mm		No	F3SN-B□□□□P70
							Yes	F3SN-B□□□□P70-01

*1. Models with NPN transistor outputs are also available as options. For details on the method for securing safety by using an NPN transistor for output, contact your OMRON representative.

*2. The □□□□ in the model numbers indicates the protective height (in mm). Refer to "Safety Light Curtain Model List" on page 4 for model number details.

*3. Safety Light Curtains with model numbers ending in -02 through -05, provided with different connector configurations, are also available as options. Consult with your dealer or OMRON representative when ordering these models.

F3SH-A Multi-beam Safety Sensors (Type 4)

Infrared

Beam gap	Appearance	Operating range	Number of beams	Outermost beam gap	Connector for series-connection	Model *
300 mm (for whole body protection)			4	900 mm	No	F3SH-A09P03
					Yes	F3SH-A09P03-01

* Safety Light Curtains of model numbers ending in -02 through -05, provided with different connector configurations, are also available as options. Consult with your dealer or OMRON representative when ordering this model.

**F3SN-A□□□□P40(-01),
F3SN-B□□□□P40(-01)**

Model	Protective height	Number of beams
F3SN-A0217P40(-01)	217	7
F3SN-A0247P40(-01)	247	8
F3SN-A0277P40(-01)	277	9
F3SN-A0307P40(-01)	307	10
F3SN-A0337P40(-01)	337	11
F3SN-A0367P40(-01)	367	12
F3SN-A0397P40(-01)	397	13
F3SN-A0427P40(-01)	427	14
F3SN-A0457P40(-01)	457	15
F3SN-A0487P40(-01)	487	16
F3SN-A0517P40(-01)	517	17
F3SN-A0547P40(-01)	547	18
F3SN-A0577P40(-01)	577	19
F3SN-A0607P40(-01)	607	20
F3SN-A0637P40(-01)	637	21
F3SN-A0667P40(-01)	667	22
F3SN-A0697P40(-01)	697	23
F3SN-A0727P40(-01)	727	24
F3SN-A0757P40(-01)	757	25
F3SN-A0787P40(-01)	787	26
F3SN-A0817P40(-01)	817	27
F3SN-A0847P40(-01)	847	28
F3SN-A0877P40(-01)	877	29
F3SN-A0907P40(-01)	907	30
F3SN-A0937P40(-01)	937	31
F3SN-A0967P40(-01)	967	32
F3SN-A0997P40(-01)	997	33

Model	Protective height	Number of beams
F3SN-A1027P40(-01)	1027	34
F3SN-A1057P40(-01)	1057	35
F3SN-A1087P40(-01)	1087	36
F3SN-A1117P40(-01)	1117	37
F3SN-A1147P40(-01)	1147	38
F3SN-A1177P40(-01)	1177	39
F3SN-A1207P40(-01)	1207	40
F3SN-A1237P40(-01)	1237	41
F3SN-A1267P40(-01)	1267	42
F3SN-A1297P40(-01)	1297	43
F3SN-A1327P40(-01)	1327	44
F3SN-A1357P40(-01)	1357	45
F3SN-A1387P40(-01)	1387	46
F3SN-A1417P40(-01)	1417	47
F3SN-A1447P40(-01)	1447	48
F3SN-A1477P40(-01)	1477	49
F3SN-A1507P40(-01)	1507	50
F3SN-A1537P40(-01)	1537	51
F3SN-A1567P40(-01)	1567	52
F3SN-A1597P40(-01)	1597	53
F3SN-A1627P40(-01)	1627	54
F3SN-A1657P40(-01)	1657	55
F3SN-A1687P40(-01)	1687	56
F3SN-A1717P40(-01)	1717	57
F3SN-A1747P40(-01)	1747	58
F3SN-A1777P40(-01)	1777	59
F3SN-A1807P40(-01)	1807	60

**F3SN-A□□□□P70(-01),
F3SN-B□□□□P70(-01)**

Model	Protective height	Number of beams
F3SN-A0277P70(-01)	277	5
F3SN-A0337P70(-01)	337	6
F3SN-A0397P70(-01)	397	7
F3SN-A0457P70(-01)	457	8
F3SN-A0517P70(-01)	517	9
F3SN-A0577P70(-01)	577	10
F3SN-A0637P70(-01)	637	11
F3SN-A0697P70(-01)	697	12
F3SN-A0757P70(-01)	757	13
F3SN-A0817P70(-01)	817	14
F3SN-A0877P70(-01)	877	15
F3SN-A0937P70(-01)	937	16
F3SN-A0997P70(-01)	997	17
F3SN-A1057P70(-01)	1057	18
F3SN-A1117P70(-01)	1117	19
F3SN-A1177P70(-01)	1177	20
F3SN-A1237P70(-01)	1237	21
F3SN-A1297P70(-01)	1297	22
F3SN-A1357P70(-01)	1357	23
F3SN-A1417P70(-01)	1417	24
F3SN-A1477P70(-01)	1477	25
F3SN-A1537P70(-01)	1537	26
F3SN-A1597P70(-01)	1597	27
F3SN-A1657P70(-01)	1657	28
F3SN-A1717P70(-01)	1717	29
F3SN-A1777P70(-01)	1777	30

Accessories (Optional)

Control Unit

Appearance	Output	Model	Remarks
	Relay, 3NO + 1NC	F3SP-B1P	For connection with the F3SN-A, F3SN-B, and F3SH-A, use F39-JC□B cables fitted with connectors at both ends.

OMRON offers many Safety Application Controllers to help you build safety circuits. Refer to Safety Application Controller Product Selection and specifications (Cat. No. Y106).

Setting Console

Appearance	Model	Accessories
	F39-MC11	Branching Connector (1), Connector Cap (1), Special Cable (2 m), Instruction Manual

Maintenance Tool *

Appearance	Model	Applicable Sensors	Accessories
	F39-MT11	F3SN-A series F3SN-B series F3SH-A series	Branching Connector (1), Connector Cap (1), Special Cable (2 m), Special Cable with Plug (0.3 m), Instruction Manual

* For detail, see the product datasheet (Cat. No. E355).

Branching Connector

Appearance	Model	Remarks
	F39-CN1	Purchase this connector when needed additionally for installing the F39-MC11.

Cable with Connector on One End (for Emitter and Receiver Set)

Appearance	Cable length	Specification	Model
	3 m	M12 connector (8 pin)	F39-JC3A
	7 m		F39-JC7A
	10 m		F39-JC10A
	15 m		F39-JC15A

Cables with Connectors on Both Ends (for Emitter and Receiver Set)

Appearance	Cable length	Specification	Model	Application
	0.2 m	M12 connector (8 pins)	F39-JCR2B	Series connection or connection with F3SP-B1P
	0.5 m		F39-JCR5B	
	3 m		F39-JC3B	
	5 m		F39-JC5B	Connection with F3SP-B1P *1
	7 m		F39-JC7B	
	10 m		F39-JC10B	
	15 m		F39-JC15B	
	20 m		F39-JC20B	
	0.2 m	M12 connector (8 pins)	F39-JCR2C	Connection with G9SA-300-SC *1 *2
	1 m		F39-JC1C	
	3 m		F39-JC3C	
	7 m		F39-JC7C	
	10 m		F39-JC10C	
	15 m		F39-JC15C	

*1. Cannot be used for series-connection purpose.

*2. When two or more cables have to be used for connection with the G9SA-300-SC, connect the necessary number of F39-JC□B cables to one F39-JC□C cable.

(Example) When a 35 m long cable is required, connect two F39-JC10B cables to one F39-JC15C.

External Indicators (Separate Models for Emitters and Receivers)

Appearance	Specification	Indicator	Type	Model
	M12 connector for PNP output	Red	Emitter	F39-A01PR-L
			Receiver	F39-A01PR-D
		Green	Emitter	F39-A01PG-L
			Receiver	F39-A01PG-D

Note: These indicators are used for connecting with series-connection type emitters/receivers (models ending in -01). (The Indicator must be secured separately for models ending in -04 or -05.) The desired turn-ON timing (type of signal) can be selected on setting console.

Mirrors (Reduce Operating Range by 12% with Each Unit)

Mirror material	Width (mm)	Depth (mm)	Length (mm)	Model
Glass mirror	145	32	406	F39-MLG0406
			610	F39-MLG0610
			711	F39-MLG0711
			914	F39-MLG0914
			1,067	F39-MLG1067
			1,219	F39-MLG1219
			1,422	F39-MLG1422
			1,626	F39-MLG1626
			1,830	F39-MLG1830
			2,134	F39-MLG2134

**Spatter Protection Covers (Include Two Pieces for Emitter and Receiver)
(Reduces Operating Range by 10% with Each Unit)**

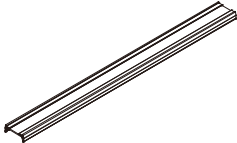
Appearance	Applicable sensor	Model
	F3SN-A□□□□P14	F39-HN□□□□-14
	F3SN-A□□□□P25(-01) F3SN-A□□□□P40(-01) F3SN-A□□□□P70(-01)	F39-HN□□□□-25
	F3SN-B□□□□P25 F3SN-B□□□□P40 F3SN-B□□□□P70	
	F3SH-A09P03(-01)	F39-HH09-03

Note: The same 4-digit numbers as the protective heights (□□□□ in the light curtain type names) are substituted by □□□□ in the model names.

Spatter Protection Slit Covers (Include Two Pieces for Emitter and Receiver) *

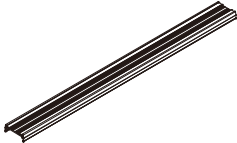
Appearance	Applicable sensor	Model	
		Slit width: 1.15 mm	Slit width: 0.6 mm
	F3SN-A□□□□P14(-01)	F39-HS□□□□A-14	F39-HS□□□□B-14
	F3SN-A□□□□P25(-01) F3SN-A□□□□P40(-01) F3SN-A□□□□P70(-01)	F39-HS□□□□A-25	F39-HS□□□□B-25
	F3SN-B□□□□P25 F3SN-B□□□□P40 F3SN-B□□□□P70		
	F3SH-A09P03(-01)	F39-HSH09A-03	F39-HSH09B-03

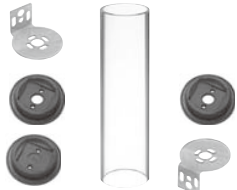

* Operating range will decrease substantially. Refer to "Specifications" on page 12 for details.

Environment-resistant Enclosures (Package of a Pipe, Gasket, and Bracket) *



Appearance	Applicable sensor	Model
	F3SN-A□□□□P14(-01)	F39-HP□□□□-14
	F3SN-A□□□□P25(-01) F3SN-A□□□□P40(-01) F3SN-A□□□□P70(-01)	F39-HP□□□□-25
	F3SN-B□□□□P25 F3SN-B□□□□P40 F3SN-B□□□□P70	
	F3SH-A09P03(-01)	F39-HPH09-03

* Purchase 2 sets when using both an emitter and a receiver.

Multi-beam Sensor Support Stands/Mirror Stands

Appearance	Specification	Model	Remarks
	Stand unit Materials Base:STKM (base) SUS304 (leaf spring) Pipe, bolts and nuts: SUS304 Weight: 11.8 kg	F39-ST1	Minimum order quantity: 1 pc. (In total, 2 stands are required for each F3SH-A: one for the emitter and the other for the receiver.)
	Mounting bracket Materials: Aluminum Weight: 250 g	F39-L22	Minimum order quantity: 1 pc. (In total, 6 brackets are required for each F3SH-A: 3 units each for emitter and receiver. These brackets are not required for the F39-MLG series reflection mirrors, since these mirrors are supplied together with a specially designed adapter.)

Mounting Brackets for Sensors (Optional)

Appearance	Specification	Model	Remarks
	Wall mounting bracket Material: Iron (zinc plating) *	F39-L18	For emitter: 2 pcs. For receiver: 2 pcs. Total: 4pcs./set
	Free-location bracket Materials: Zinc die-cast (zinc plating) Note: Not provided with an angle deflection mechanism for beam control.	F39-L19	Minimum order quantity: 1 pc.
	Free-location bracket Materials Sensor fixing element: Zinc die-cast (zinc plating) Mounting bracket: Iron (zinc plating) Note: Provided with an angle deflection mechanism for beam control	F39-L20	Minimum order quantity: 1 pc.

* Use these brackets for sensors having an operating range where no intermediate bracket is required (with an operating range of less than 640 mm).

Test Rods (Optional)

Appearance	Applicable sensor	Specification	Model
	F3SN-A□□□□P14(-01)	14 mm-dia. (provided with the sensor)	F39-TR14
		Used for checking the setting condition of single-beam floating blanking	F39-TR23
	F3SN-A□□□□P25(-01)	Used for checking the setting condition of two-beam floating blanking	F39-TR32
		25 mm-dia. (provided with the sensor)	F39-TR25 *1
		Used for checking the setting condition of single-beam floating blanking	F39-TR40 *2

*1. Also provided with the F3SN-B□□□□P25.

*2. Also provided with the F3SN-A□□□□P40 and F3SN-B□□□□P40.

Specifications (For details, refer to the instruction manual.)

Main Units

F3SN-A/F3SH-A

Model *8	Stand- alone	F3SN-A□□□□P14 *1	F3SN-A□□□□P25 *1	F3SN-A□□□□P40 *1	F3SN-A□□□□P70 *1	F3SH-A09P03
Item	Series connection	F3SN-A□□□□P14-01 *1 *2	F3SN-A□□□□P25-01 *1	F3SN-A□□□□P40-01 *1	F3SN-A□□□□P70-01 *1	F3SH-A09P03-01
Sensor type	Type 4 Safety Light Curtain					
Applicable safety category	Category 4, 3, 2, 1, or B					
Operating range	0.2 to 7 m		0.2 to 10 m			
Beam gap (P)	9 mm		15 mm		30 mm	
Number of beams (n)	21 to 125 (odd numbers only)		13 to 120		7 to 60	
Protective height (PH)	189 to 1125 mm PH = n × P		217 to 1822 mm PH = (n - 1) × P + 37		217 to 1807 mm PH = (n - 1) × P + 37	
Outermost beam gap	---					900 mm
Detection capability	Opaque objects: 14 mm in diameter		Opaque objects: 25 mm in diameter		Opaque objects: 40 mm in diameter	
Effective aperture angle (EAA)	Within ±2.5° for the emitter and receiver at a detection distance of at least 3 m according to IEC 61496-2					
Light source (emitted wavelength)	Infrared LED (870 nm)					
Power supply voltage (Vs)	24 VDC ±10% (ripple p-p 10% max.)					
Current consumption (no load)	Emitter	Up to 50 beams: 140 mA max., 51 to 85 beams: 155 mA max., 86 beams and more: 170 mA max.				140 mA max.
	Receiver	Up to 50 beams: 100 mA max., 51 to 85 beams: 110 mA max., 86 beams and more: 120 mA max.				100 mA max.
Control outputs (OSSD)	Two PNP transistor outputs, load current 300 mA max., residual voltage 2 V max. (except for voltage drop due to cable extension)					
Auxiliary output (non-safety output)	One PNP transistor output, load current 50 mA max., residual voltage 2 V max. (except for voltage drop due to cable extension)					
External indicator output (non-safety output) *3	One PNP transistor output, load current 40 mA max., residual voltage 2 V max. (except for voltage drop due to cable extension)					
Output operation mode	Control output: Light-ON Auxiliary output: Dark-ON (can be changed by the F39-MC11) External indicator output: Light-ON (can be changed by the F39-MC11) *3					
Input voltage	Test input, interlock selection input, reset input, and external relay monitor input voltages; ON voltage: 9 to 24 V (with a sink current 3 mA max.), OFF voltage: 0 to 1.5 V or open					
Test functions	<ul style="list-style-type: none"> Self test (when power is turned ON and while power is supplied, one cycle during response time) External test (emission stop function by test input) 					
Mutual interference prevention function *3	Time-shared beam projection system by series connection <ul style="list-style-type: none"> Number of series connected light curtains: Up to 3 sets Number of beams: Up to 240 beams Length of the series connection cable: 3 m max. 					
Safety functions	<ul style="list-style-type: none"> Auto-reset/manual reset (interlock) *4 EDM (External Device Monitor) Fixed blanking *5 Floating blanking *5 				<ul style="list-style-type: none"> Auto-reset mode/manual reset mode (interlock) *4 EDM (External Device Monitor) 	
Protective circuits	Output short-circuit protection, power supply reverse polarity protection					
Response time (under stable light incident condition)	ON to OFF: 10 to 15.5 ms max. OFF to ON: 40 to 62 ms max.				ON to OFF: 10 ms max. OFF to ON: 40 ms max.	
Startup waiting time	1 s max.					
Ambient operating light intensity	Incandescent lamp: 3000 lx max. (light intensity on the receiver surface) Sunlight: 10000 lx max. (light intensity on the receiver surface)					
Ambient temperature	Operating: -10 to 55°C, storage: -30 to 70°C (with no icing or condensation)					
Ambient humidity	Operating/storage: 35% to 95% (with no condensation)					
Insulation resistance	20 MΩ min. (at 500 VDC)					
Dielectric strength	1000 VAC 50/60 Hz 1 min.					
Vibration resistance (malfunction)	10 to 55 Hz, 0.7-mm double amplitude, 20 sweeps in X, Y and Z directions					
Shock resistance (malfunction)	100 m/s ² , 1000 times in X, Y and Z directions					
Degree of protection	IP65 (IEC60529)					
Connection method	M12 connector (8 pins)					

Model *8	Stand-alone	F3SN-A□□□□P14 *1	F3SN-A□□□□P25 *1	F3SN-A□□□□P40 *1	F3SN-A□□□□P70 *1	F3SH-A09P03
Item	Series connection	F3SN-A□□□□P14-01 *1 *2	F3SN-A□□□□P25-01 *1	F3SN-A□□□□P40-01 *1	F3SN-A□□□□P70-01 *1	F3SH-A09P03-01
Weight (packed state)	Weight (g) = (Detection width) × 2.4 + α + β Detection width of 189 to 639 mm: α = 700, Detection width of 652 to 1,267 mm: α = 800, Detection width of 1,282 to 1,822 mm: α = 900, Model with no suffix or -01: β = 0, Model with suffix -02, -03, or -05: β = 100, Model with suffix -04: β = 200					
Materials	Case: Aluminum, cap: Zinc die-cast, optical cover: PMMA (acrylic resin), Cable: Oil-resistant PVC					
Accessories	Test rod *6, instruction manual, error mode label, mounting brackets (top and bottom), mounting brackets (intermediate) *7					
Applicable standards	IEC61496-1, EN61496-1 Type 4 ESPE (Electro-Sensitive Protective Equipment) IEC61496-2 Type 4 AOPD (Active Opto-electronic Protective Devices)					

- *1. The 4 digits in □□□□ in the model number represent the protective height. Use the formula given in the information on protective height specifications to calculate the height.
For example, if the beam gap is 9 mm, and the No. of beams is 21, the protective height will be 9 × 21 = 189 mm. The model with this protective height is F3SN-A0189P14.
- *2. F3SN-A□□□□P14-01 is a customized model. Consult with your dealer or OMRON representative when ordering this model.
- *3. Only models ending in -01, -03, -04, or -05 have this output and functionality.
- *4. For the factory setting, the manual reset mode is set to the “start/restart” interlock.
Using the F39-MC11 can select either the start interlock or the restart interlock.
- *5. For the factory setting, the function is not set. It can be enabled with the F39-MC11.
- *6. Not provided with the F3SN-A□□□□P70 and F3SH-A.
- *7. The intermediate mounting bracket is supplied with the following types:
Types which have the total length of the light curtain from 640 mm to 1280 mm: 1 set for each of emitter and receiver.
Types which have the total length of the light curtain over 1280 mm: 2 sets for each of emitter and receiver.
- *8. Models with different connector configurations are also available as options. Refer to “Many Connector Variations” on page 2.

F3SN-B (Different from specifications of F3SN-A)

Item	Model *6	F3SN-B□□□□P25	F3SN-B□□□□P40	F3SN-B□□□□P70
Sensor type	Type 2 Safety Light Curtain			
Applicable safety category	Category 2, 1, or B			
Operating range	0.2 to 10.0 m			
Beam gap (P)	15 mm	30 mm	60 mm	
Number of beams (n)	13 to 119 (noncontinuous)	7 to 60 (noncontinuous)	5 to 30	
Protective height (PH) (PH = (n - 1) × P + 37)	217 to 1807 mm	217 to 1807 mm	277 to 1777 mm	
Detection capability	Opaque objects: 25 mm in diameter	Opaque objects: 40 mm in diameter	Opaque objects: 70 mm in diameter	
Effective aperture angle (EAA) (beam spread angle)	Within ±5° for the emitter and receiver at a detection distance of at least 3 m according to IEC 61496-2			
Light source (emitted wavelength)	Infrared LED (870 nm)			
Power supply voltage (Vs)	24 VDC ±10% (ripple p-p 10% max.)			
Current consumption (no load)	Emitter	Up to 50 beams: 140 mA max., 51 to 85 beams: 155 mA max., 86 beams and more: 170 mA max.		
	Receiver	Up to 50 beams: 100 mA max., 51 to 85 beams: 110 mA max., 86 beams and more: 120 mA max.		
Control outputs (OSSD) *1	Two PNP transistor outputs, load current 300 mA max., residual voltage 2 V max. (except for voltage drop due to cable extension)			
Auxiliary output (non-safety output)	One PNP transistor output, load current 50 mA max., residual voltage 2 V max. (except for voltage drop due to cable extension)			
Output operation mode *1	Control output: Light-ON, Auxiliary output: Dark-ON			
Input voltage	For test input, interlock selection input, reset input, and external relay monitor input voltages; ON voltage: 9 to 24 V (sink current: 3 mA max.), OFF voltage: 0 to 1.5 V or open			
Test functions	<ul style="list-style-type: none"> • Self test (when power is ON and period is 1 s or less) • External test (light emission stop function by test input) 			
Safety functions *2 *3	<ul style="list-style-type: none"> • Auto-reset/manual reset (start/restart interlock) • EDM (External Device Monitor) 			
Protective circuits	Output short-circuit protection, reverse polarity protection			
Response time (under stable light incident condition)	ON to OFF: 10 to 15 ms max. OFF to ON: 40 to 60 ms max.			
Startup waiting time	1 s max.			
Ambient operating light intensity	Incandescent lamp: 3000 lx max. (light intensity on the receiver surface) Sunlight: 10000 lx max. (light intensity on the receiver surface)			
Ambient temperature	Operating: -10 to 55°C, storage: -30 to 70°C (with no icing or condensation)			
Ambient humidity	Operating/storage: 35% to 95% (with no condensation)			
Insulation resistance	20 MΩ min. (at 500 VDC)			
Dielectric strength	1000 VAC 50/60 Hz 1 min.			
Vibration resistance (malfunction)	10 to 55 Hz, 0.7-mm double amplitude, 20 sweeps in X, Y and Z directions			
Shock resistance (malfunction)	100 m/s ² , 1000 times in X, Y and Z directions			
Degree of protection	IP65 (IEC60529)			
Connection method	M12 connector (8 pins)			
Weight (packed state)	Weight (g) = (Detection width) × 2.4 + α + β Detection width of 189 to 639 mm: α = 700, Detection width of 652 to 1,267 mm: α = 800, Detection width of 1,282 to 1,822 mm: α = 900, Model with no suffix or -01: β = 0, Model with suffix -02, -03, or -05: β = 100, Model with suffix -04: β = 200			
Materials	Case: Aluminum, cap: Zinc die-cast, optical cover: PMMA (Acrylic resin)			
Accessories	Test rod *4, instruction manual, mounting brackets (top and bottom), mounting brackets (intermediate) *5, error mode label			
Use of setting console	Not permitted			
Applicable standards	IEC61496-1, EN61496-1 Type 2 ESPE (Electro-Sensitive Protective Equipment) IEC61496-2 Type 2 AOPD (Active Opto-electronic Protective Devices)			

*1. A safety circuit has been adopted. Please note that the control logic (ON/OFF) may differ from conventionally used logic.
 *2. The manual reset mode is set to the "start/restart" interlock. It is impossible to select interlock only or restart interlock only.
 *3. No floating blanking or fixed blanking function is provided.
 *4. Not provided with the F3SN-B□□□□P70.
 *5. The intermediate mounting bracket is supplied with the following types:
 Types which have the total length of the light curtain from 640 mm to 1280 mm: 1 set for each of emitter and receiver.
 Types which have the total length of the light curtain over 1280 mm: 2 sets for each of emitter and receiver.
 *6. Models with different connector configurations are also available as options. Refer to "Many Connector Variations" on page 2.

Accessories

Control Units

Item	Model	F3SP-B1P	G9SA-300-SC *
Applicable sensor		F3SN-A, F3SN-B, F3SH-A	
Supply voltage		24 VDC ±10%	
Power consumption		1.7 W DC max. (does not include the sensor's current consumption)	24 VDC: 0.7 W DC max. (does not include the sensor's current consumption)
Operating time		100 ms max. (does not include the sensor's response time)	300 ms max. (does not include the sensor's response time and bounce time)
Response time		10 ms max. (does not include the sensor's response time)	10 ms max. (does not include the sensor's response time and bounce time)
Relay output	No. of contact	3 NO + 1 NC	3 NO
	Rated load	25 VAC, 5 A (cos diameter = 1), 30 VDC, 5 A L/R = 0 ms	250 VAC, 5 A
	Rated carry voltage	5 A	
Connection method	Between sensor's	M12 connector (8 pins)	
	Other	Terminal block	
Weight (packed state)		Approx. 280 g	Approx. 300 g
Accessory		Instruction manual	

* For further details on the G9SA-300-SC, refer to G9SA-300-SC.

Setting Console

Item	Model	F39-MC11
Applicable sensor		F3SN-A, F3SH-A
Supply voltage		24 VDC ±10% (provided from the sensor)
Connection method		Cable (included)
Weight (packed state)		360 g
Accessories		One branching connector, 2-m cable, one connector cap, instruction manual

For details on the setting console, refer to the instruction manual provided with the product.

External Indicators

Item	Model	F39-A01PR-L (Emitter) F39-A01PR-D (Receiver)	F39-A01PG-L (Emitter) F39-A01PG-D (Receiver)
Applicable sensor		F3SN-A□□□□P□□□(-01, -03, -04, -05) * F3SH-A09P03-01	
Light source		Red LED	Green LED
Supply voltage		24 VDC ±10% (provided from the sensor)	
Current consumption		50 mA max. (provided from the sensor)	
Connection method		M12 connector (8 pins)	
Weight (packed state)		Approx. 80 g	

* The indicator must be secured separately for models ending in "-04" or "-05." For the F3SN-B, only light-ON mode can be used.

Spatter Protection Slit Covers

Item	Model	F39-HS□□□□A-14	F39-HS□□□□B-14	F39-HS□□□□A-25 F39-HSH09A-03	F39-HS□□□□B-25 F39-HSH09B-03
Applicable sensor		F3SN-A□□□□P14(-01) F3SN-A□□□□P□□□(-01), F3SN-B□□□□P□□□(-01), F3SH-A09P03(-01)			
Operating range (typical value) *	When one cover is used	3 m	2 m	5.5 m	3.5 m
	When two covers are used	1 m	0.5 m	2 m	1 m
Distance that does not cause mutual interference (typical value)	When one cover is used	6.5 m	4.8 m	12.2 m	7.8 m
	When two covers are used	2.4 m	1.2 m	4.4 m	2.1 m

* The maximum distance that can turn ON all of the five light intensity level indicators.

Environment-resistant Enclosures

Item	Model	F39-HP□□□□-14	F39-HP□□□□-25 F39-HPH09-03
Applicable sensor		F3SN-A□□□□P14(-01)	F3SN-A□□□□P□□□(-01), F3SN-B□□□□P□□□(-01), F3SH-A09P03(-01)
Operating range characteristics		0.2 to 6 m	0.2 to 10 m
Degree of protection *		IP67 (IEC60529)	
Materials		Case: Acrylic resin, rubber: NBR60, mounting bracket: SUS316L, screw: SUS316L	

* To conform to IP67, tighten the screws according to the "Cautions for Use" as described in the manual packaged together with the product.

Connections

Wiring for Sensor Only Configuration

Wiring for the Manual Reset Mode and the EDM Function

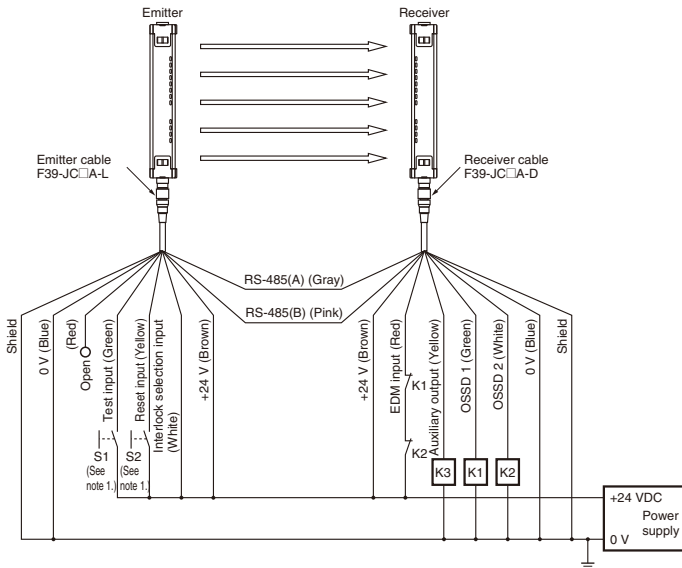

- S1: External test switch
- S2: Interlock/lockout reset switch
- S3: Lockout reset switch (If the switch is not necessary, connect between the reset input and +24 VDC.)
- K1, K2: Relay that control the dangerous zone, etc.
- K3: Load, PLC, etc. (used for monitoring)

Wiring for the Auto-reset Mode

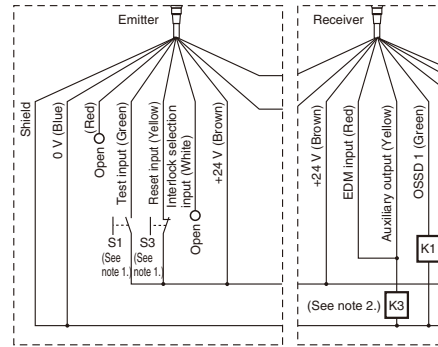

When the EDM is Not Used

When the EDM is not necessary

(1) Use the F39-MC11 to disable the EDM.

or

(2) Disable the EDM by changing the wiring as shown in the figure below, when the auxiliary output is Dark ON.

- Note: 1. Use very low load type switches.
- 2. If K3 is not necessary, short-circuit the auxiliary output with the EDM input.

Series Connection (Up to 3 Sets)

Using series connection models (model numbers ending in -01, -03, -04, -05) enables series connection as shown in the figure at the right. Either stand-alone models and the series connection models can be used for the light curtains located at the top end.

- Note: 1. To maintain performance characteristics, use the F39-JCR2B or the F39-JC3B to connect light curtains in series. The F39-JC7B, F39-JC10B, or F39-JC15B cannot be connected in series.
- 2. The F3SN and F3SH cannot be connected in series.
- 3. Series connection is possible for model numbers ending in -04 or -05 (with 0.2 m cable with connectors). Refer to page 2.

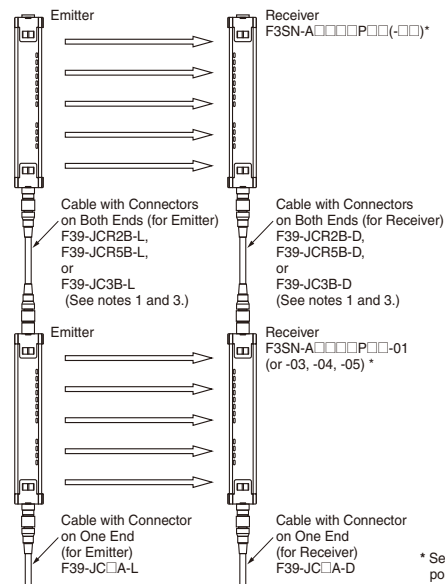

* Series connection is possible for the F3SN-B.

An Example of Safety Circuits Where the F3SP-B1P Controller is Used

For category 4 rating (F3SN-A, F3SN-A)/category 2 rating (F3SN-B)

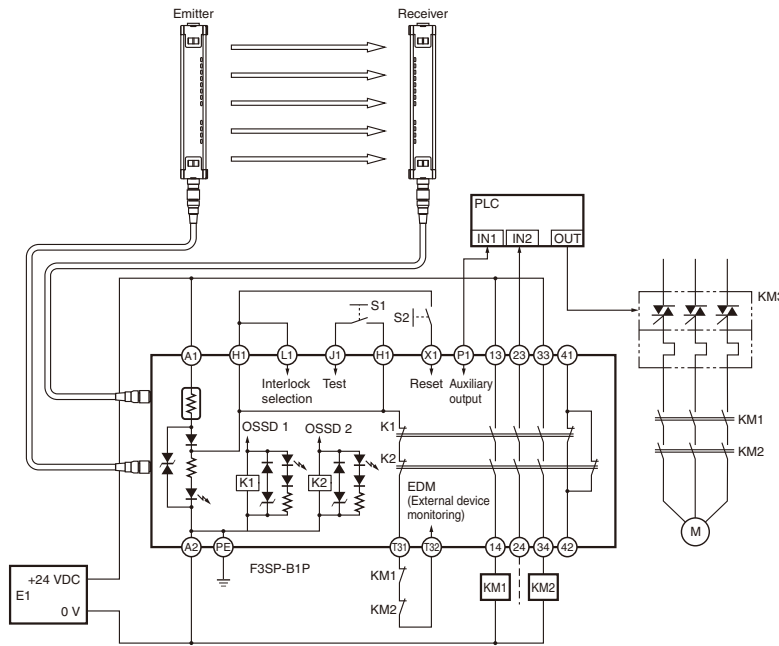

Applicable operation mode

• Manual reset mode

- S1: External test switch
- S2: Interlock/lockout reset switch
- S3: Lockout reset switch (If the switch is not necessary, connect between X1 and H1.)

KM1, KM2: Magnetic contactor

KM3: Solid-state contactor (G3J)

M: 3-phase motor

E1: 24 VDC power supply (S82K)

PLC: Programmable controller
(Used for monitoring. This is not a part of a safety system.)

Wiring for the Auto-reset mode

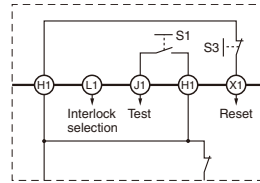

Note: 1. If the EDM is not necessary, short-circuit T31 and T32.

2. For the number and arrangement of all terminals on the F3SP-B1P, see the instruction manual packaged together with the F3SP-B1P.

I/O Circuit Diagrams

Internal Circuit Diagram

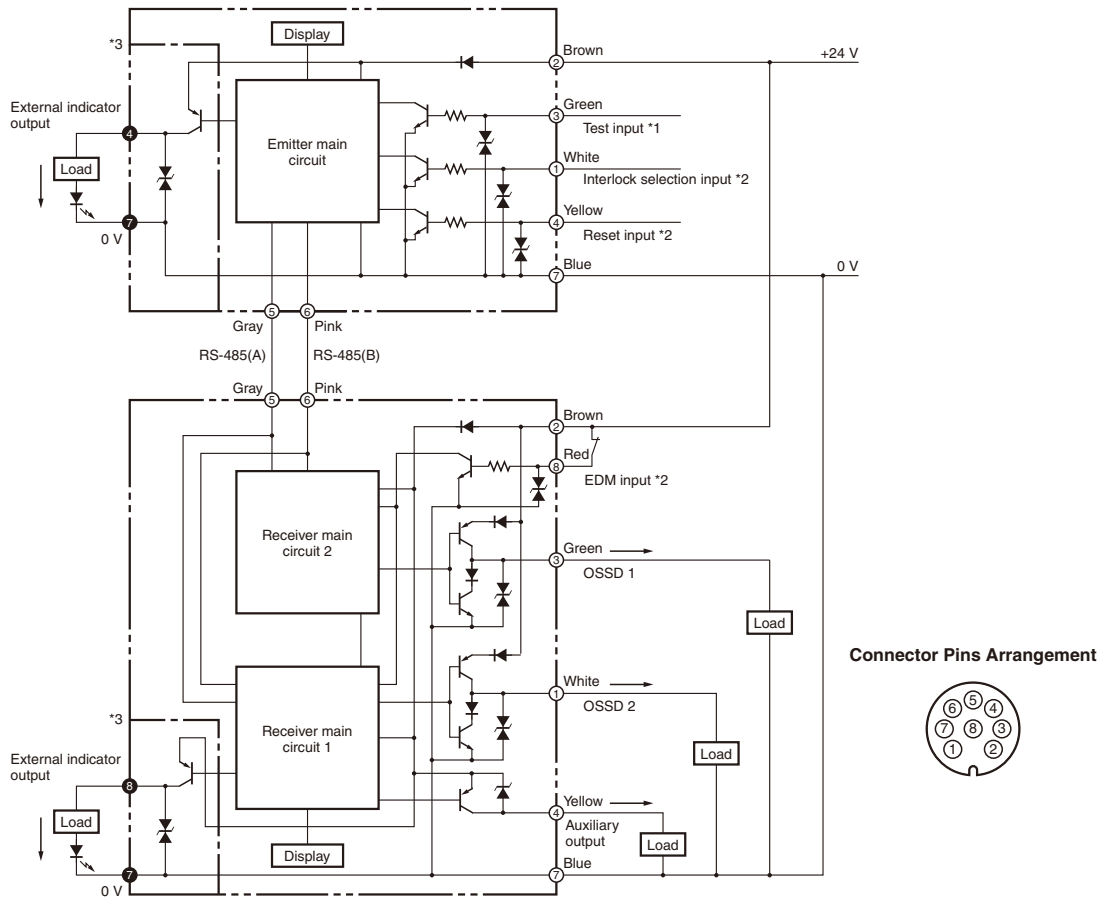

Note: The numbers in ○ indicate pin numbers of the connectors.
 The numbers in ● indicate pin numbers of the series connection connectors.
 *1. Open: normal light emission, short to the +24 VDC: stops light emission
 *2. Refer to "Connections", "Wiring for Sensor Only Configuration" on page 13.
 *3. The section encircled with the dashed line is applied for models ending in -01, -03, -04, or -05 only.

Cables with Connector on One End

Model	Internal wiring	Pin No.	Wire color	Signal name	
				Receiver	Emitter
F39-JC3A (3 m) F39-JC7A (7 m) F39-JC10A (10 m) F39-JC15A (15 m)		1	White	OSSD 2	Interlock selection input
		2	Brown	+24 V	+24 V
		3	Green	OSSD 1	Test input
		4	Yellow	Auxiliary output	Reset input
		5	Gray	RS-485(A)	RS-485(A)
		6	Pink	RS-485(B)	RS-485(B)
		7	Blue	0 V	0 V
		8	Red	EDM input	N.C.

Output waveform of the OSSD outputs

The OSSD outputs will be OFF as shown in the following figure in order to perform the OSSD circuit self-test when the light curtain is in the ON-state.

The OSSD circuit diagnosis is correct when this OFF signal is fed back. If the output signal does not contain an OFF signal, the receiver determines that there is an output circuit or wiring failure and goes into the lockout condition.

The number of OFF signals depends on the number of light curtains

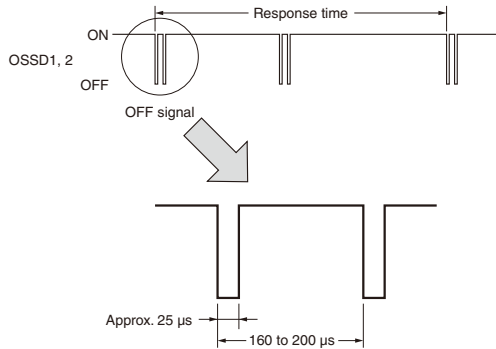

connected in series. (See the chart at left.)

In the same way, the OSSD outputs will be ON as shown in the following figure, to perform the OSSD circuit self-test when the light curtain is in the OFF-state. (See the chart below.)

Check the input response time of a machine connected to the F3SN-A carefully to ensure the machine will not malfunction due to the OFF signal.

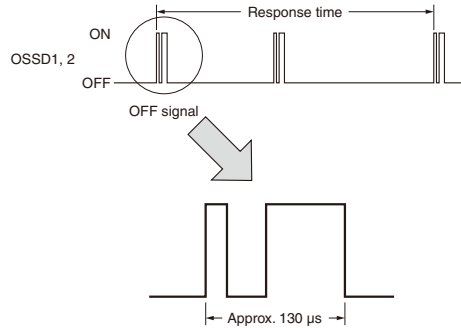

Note: This chart indicates the instance of 2 light curtains series connection.

No. of light curtains connected in series	No. of OFF signals within the response time
No	1
2 light curtains	2
3 light curtains	3

No. of light curtains connected in series	No. of ON signals within the response time
No	1
2 light curtains	2
3 light curtains	3

Names and Functions of Parts

Emitter (F3SN-A/ F3SN-B/ F3SH-A)

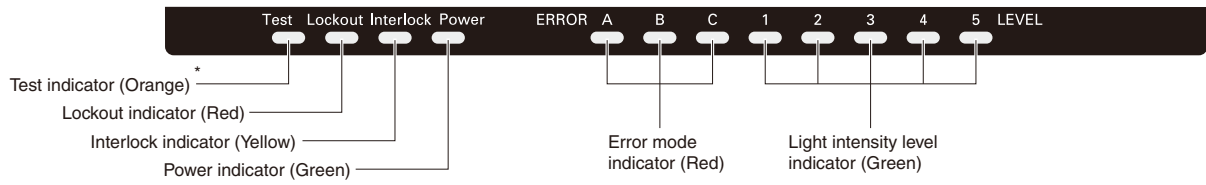

Receiver (F3SN-A)

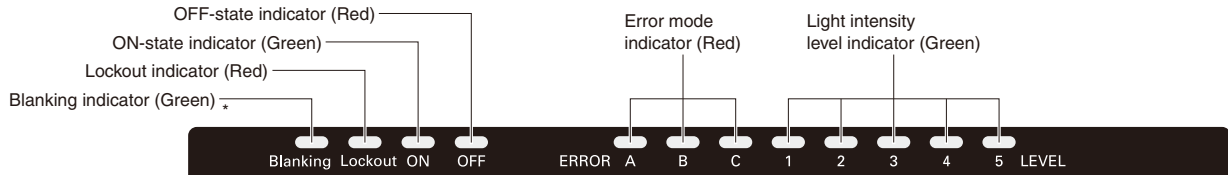

Receiver (F3SN-B)

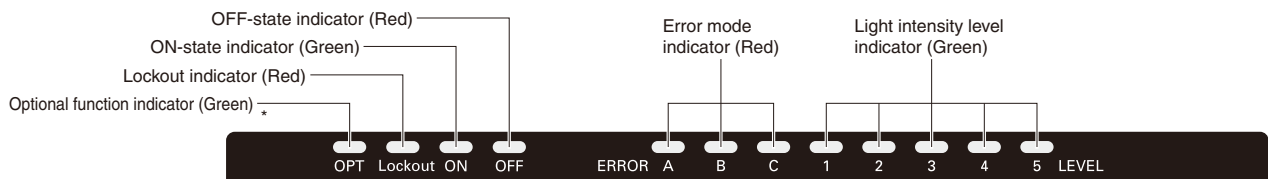

Receiver (F3SH-A)

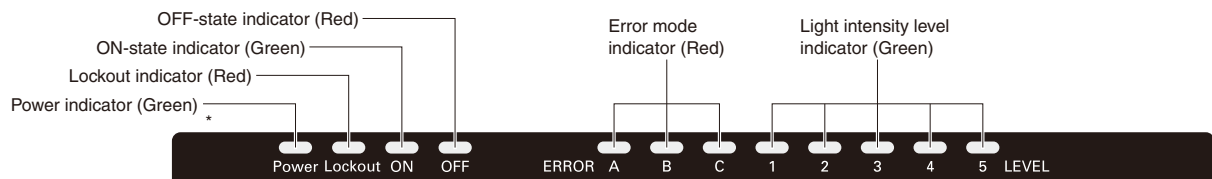

* These indicators flash to indicate the need for preventive maintenance when the total ON time exceeds 30,000 hours. (Models without this flashing function are also available as options. An “-NT” to the model number. Ask your OMRON representative for details.)

Function

Power indicator	Lit when power is supplied (always lit): F3SN-A, F3SH-A Emitter Lit when power is supplied, flashing when the F39-MC11 is connected: F3SH-A Receiver *
Interlock indicator	Lit during interlock condition
Lockout indicator	Flashing during lockout condition
Test indicator	Lit during external test *
ON-state indicator	Lit when OSSD outputs are in ON-state
OFF-state indicator	Lit when OSSD outputs are in OFF-state
Blanking indicator (F3SN-A only)	Lit when blanking is set, flashing when the F39-MC11 is connected *
Optional function indicator (F3SN-B only)	Flashing after a lapse of 30,000 hours

* These indicators flash to indicate the need for preventive maintenance when the total ON time exceeds 30,000 hours. (Models without this flashing function are also available as options. An “-NT” to the model number. Ask your OMRON representative for details.)

	1	2	3	4	5	Light intensity level
Light intensity level indicator Lit Not lit						200% and above of ON threshold level
						150 to 200% of ON threshold level
						100 to 150% of ON threshold level
						75 to 100% of ON threshold level
						50 to 75% of ON threshold level
						Less than 50% of ON threshold level

	A	B	C	Cause of error
Error mode indicator Flashing Not lit				The Interlock selection input line or the reset input line is not wired correctly or became open.
				Relay contact is welded. Releasing time of the relay takes too long. The EDM input line is not wired correctly or became open.
				Communication line (RS-485) is not wired correctly, became open, or causes other errors.
				One of the OSSD outputs is shorted or is not wired correctly. Other failure in OSSD outputs.
				Mutual interference. Interference light is received.
				Types of the receiver and emitter are not the same. Numbers of the receiver and emitter connected in series are not the same.
				External noise. Internal hardware failure of the receiver or the emitter.

Engineering Data (Typical Examples)

Parallel operating range

F3SN-A1107P14

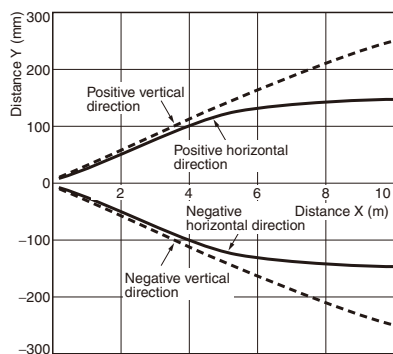

Horizontal direction Vertical direction

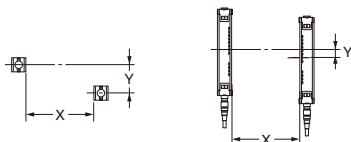

Angular range (Angle of elevation)

F3SN-A1107P14

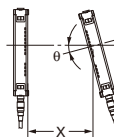
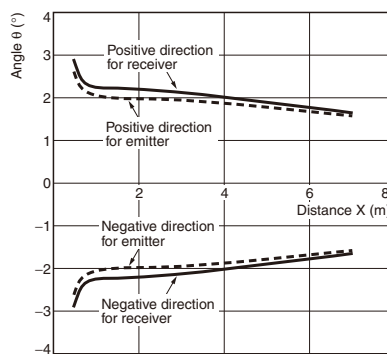

Angular range (Angle of rotation)

F3SN-A1107P14

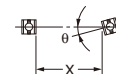
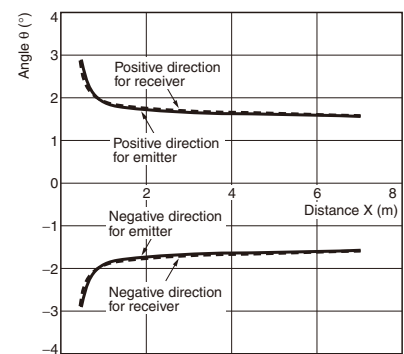

Dimensions

(Unit: mm)

Main Units Refer to the User's Manual (SCEE-713) for the dimensions of models with different connector configurations (model numbers ending in "-02" to "-05").

F3SN-A□□□□P□□(-01)
F3SN-B□□□□P□□(-01)

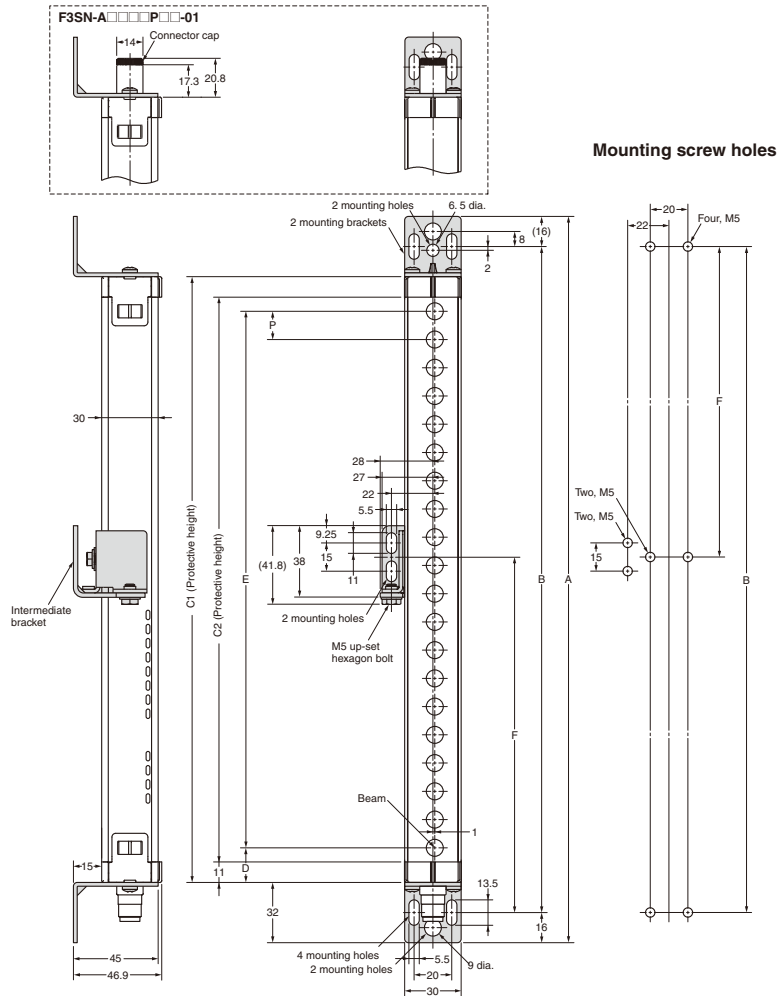

Dimensions according to the model can be calculated by using the following equations.

- F3SN-A□□□□P14(-01)
Dimension C2 (protective height): 4 digits in the model name
Dimension A = C2 + 86
Dimension B = C2 + 54
Dimension D = 15.5
Dimension E = C2 - 9
Dimension F: See the table below.
Dimension P = 9
- F3SN-A□□□□P25(-01)/P40(-01)/P70(-01), F3SN-B□□□□P25(-01)/P40(-01)/P70(-01)
Dimension C1 (protective height): 4 digits in the model name
Dimension A = C1 + 64
Dimension B = C1 + 32
Dimension D = 18.5
Dimension E = C1 - 37
Dimension F: See the table below.

C2 (protective height)	Number of intermediate Mounting Bracket	Dimension F (See note.)
to 0620	0	---
0621 to 1125	1	F = B/2

Note: If value F obtained from the above equation is not used, set F to 670 mm or less.

C1 (protective height)	Number of intermediate Mounting Bracket	Dimension F (See note.)
to 0640	0	---
0641 to 1280	1	F = B/2
1281 to 1822	2	F = B/3

Dimension P: See the table below.

Detection capability	Dimension P
25	15
40	30
70	60

F3SH-A09P03
F3SH-A09P03-01

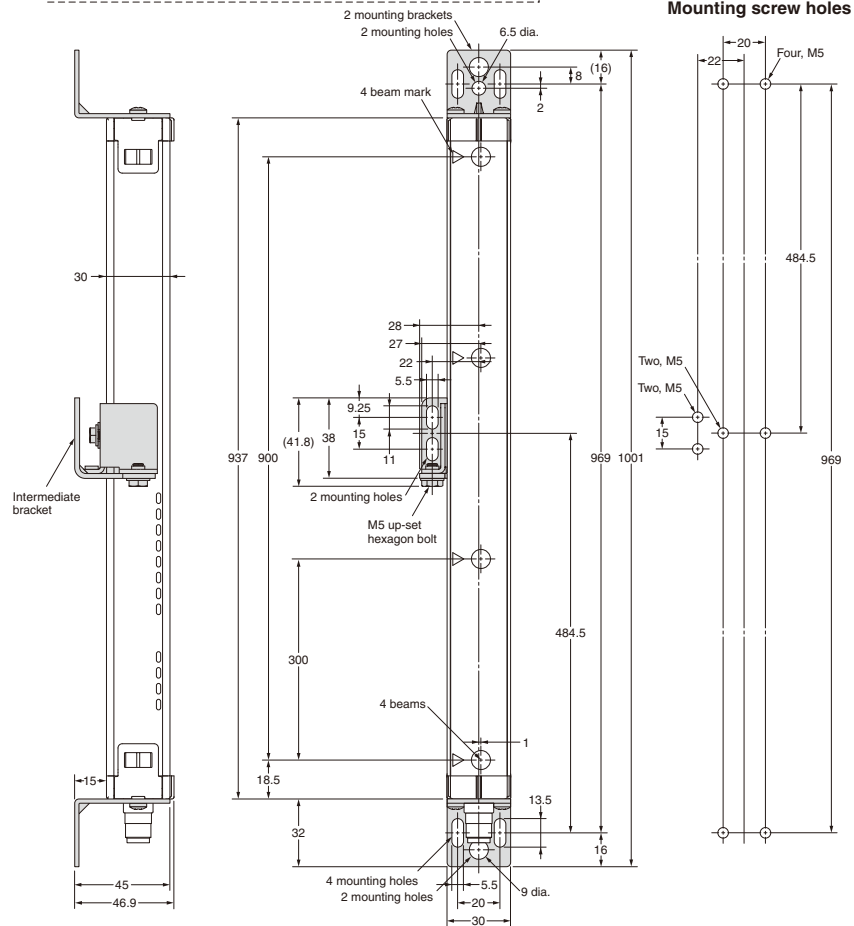
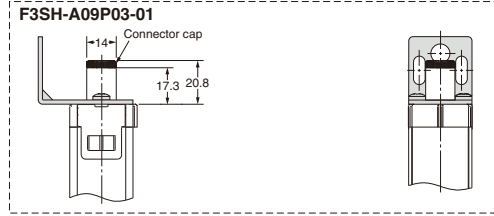
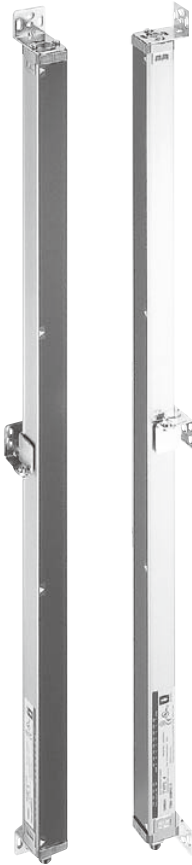

Mounting Precautions

1. The intermediate bracket (3) (see Mounting brackets (intermediate)) is shown on the left-hand side of the sensor as an example. If the intermediate bracket (3) is on the right-hand side of the sensor then the mounting holes must also be on the right-hand side.
2. When using with the cable bent, allow at least the dimensions shown on the right. (Minimum bending radius of cable: R36 mm.)

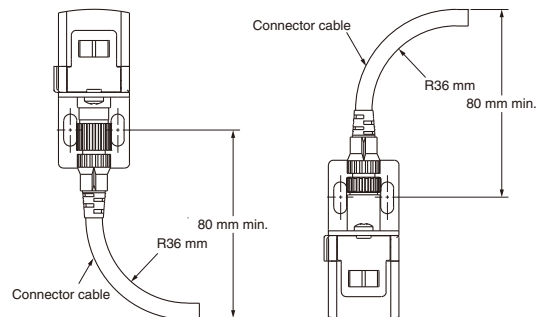

Accessories

Mounting Bracket (Top and Bottom)



Material: Iron (zinc plating)

Note: Provided with the product.

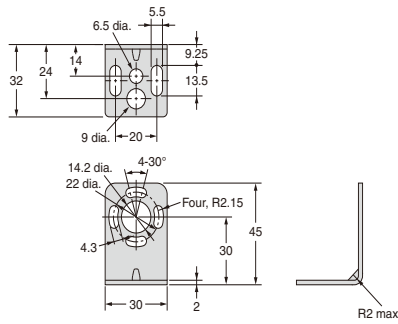

Mounting Brackets (Intermediate)



Material: Iron (zinc plating)

Note: Provided with the product. The number of brackets required depends on the total length of the Sensor.

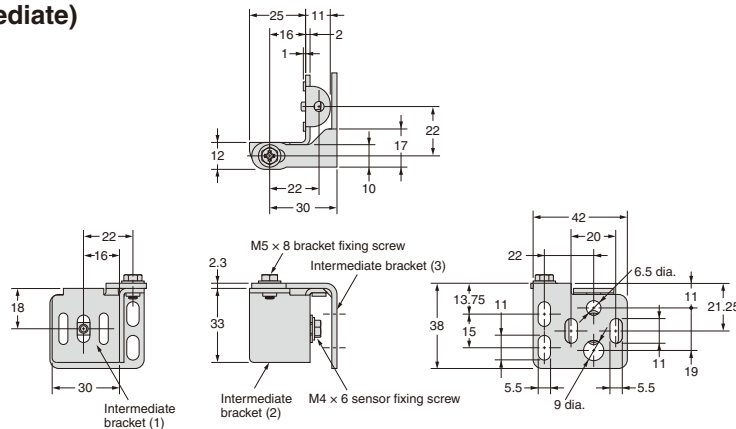

Accessories (Optional)

Cables with Connector on One End

- F39-JC3A (L = 3 m) F39-JC10A (L = 10 m)
- F39-JC7A (L = 7 m) F39-JC15A (L = 15 m)



Color: Emitter (gray)
Receiver (black)

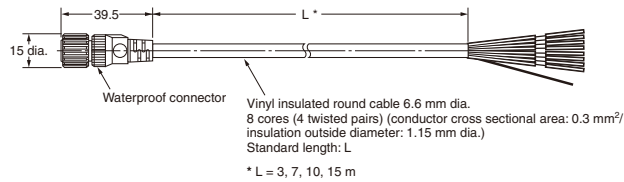

Cables with Connectors on Both Ends

- F39-JCR2B (L = 0.2 m) F39-JC7B (L = 7 m) F39-JCR2C (L = 0.2 m) F39-JC10C (L = 10 m)
- F39-JCR5B (L = 0.5 m) F39-JC10B (L = 10 m) F39-JC1C (L = 1 m) F39-JC15C (L = 15 m)
- F39-JC3B (L = 3 m) F39-JC15B (L = 15 m) F39-JC3C (L = 3 m)
- F39-JC5B (L = 5 m) F39-JC20B (L = 20 m) F39-JC7C (L = 7 m)



Color: Emitter (gray)
Receiver (black)

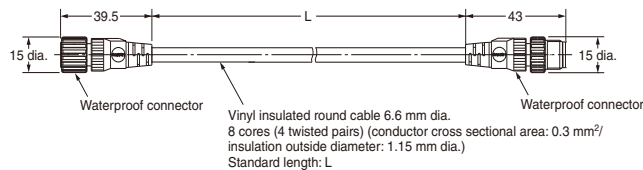

Control Unit
F3SP-B1P

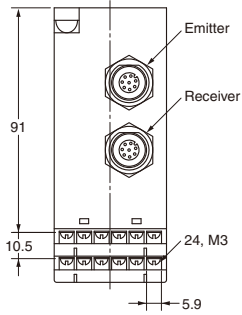

Terminal Allocations

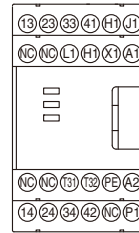

Indicators:
PWR (green), K1 (orange), K2 (orange)

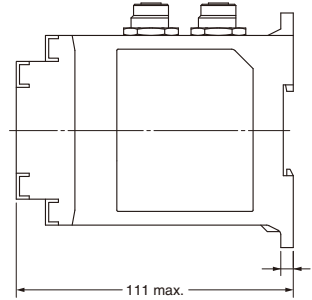
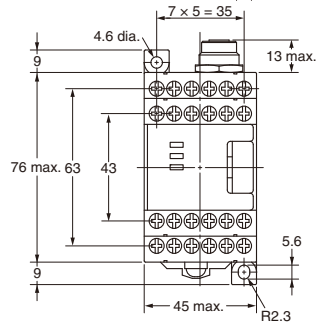

Mounting screw holes

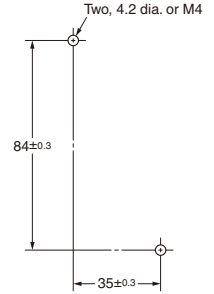

Spatter Protection Covers

- F39-HN□□□□-14
- F39-HN□□□□-25
- F39-HH09-03

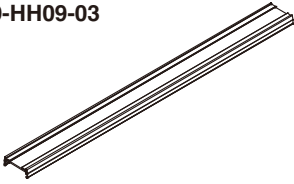

Protection cover

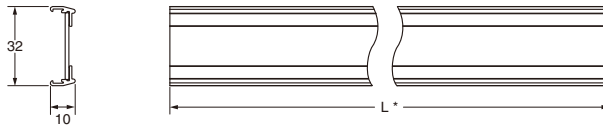

* L is as follows.

F39-HN□□□□-14 F39-HS□□□□A(B)-14	L = □□□□ mm
F39-HN□□□□-25 F39-HS□□□□A(B)-25	L = □□□□ - 22 mm
F39-HH09-03 F39-HS09A(B)-03	L = 915 mm

Materials: PC (transparent area)
ABS (non-transparent area)

Spatter Protection Slit Covers

- F39-HS□□□□A(B)-14
- F39-HS□□□□A(B)-25
- F39-HS09A(B)-03

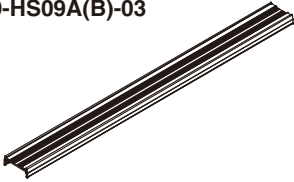

Mounting dimensions

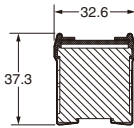

Fixing bracket

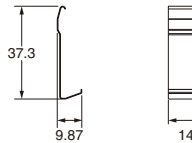

Materials: SUS

Water-resistant Case

- F39-HP□□□□-14
- F39-HP□□□□-25
- F39-HPH09-03

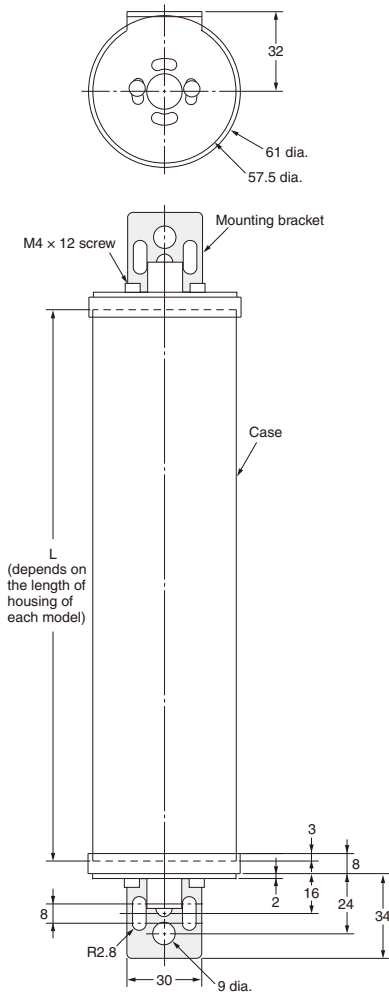

Multi-beam Sensor Support Stand/Mirror Stand

F39-ST1

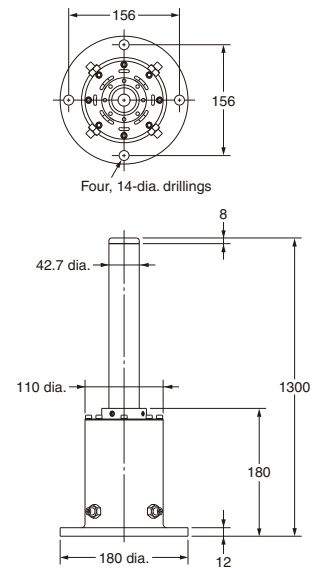

Mounting Bracket

F39-L22

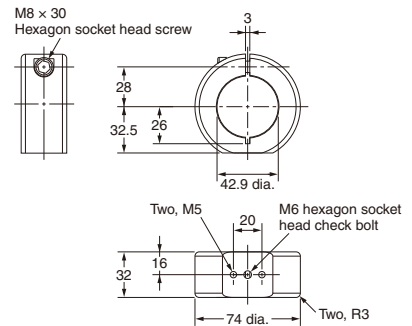

Wall Mounting Bracket

F39-L18

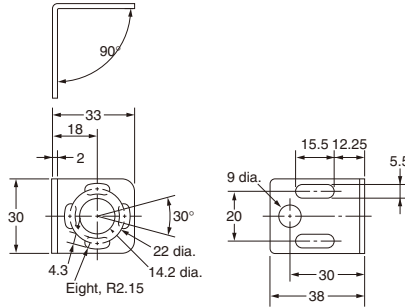

Free-location Bracket

F39-L19

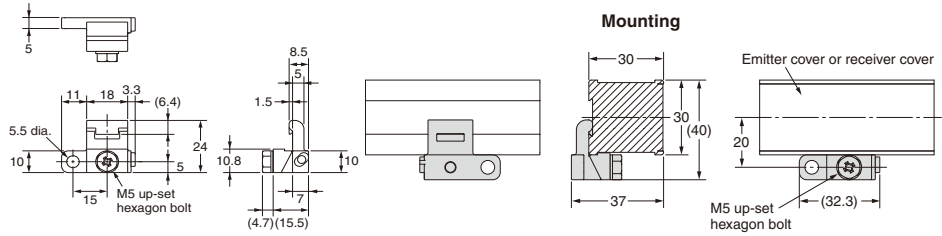

Free-location Bracket

F39-L20

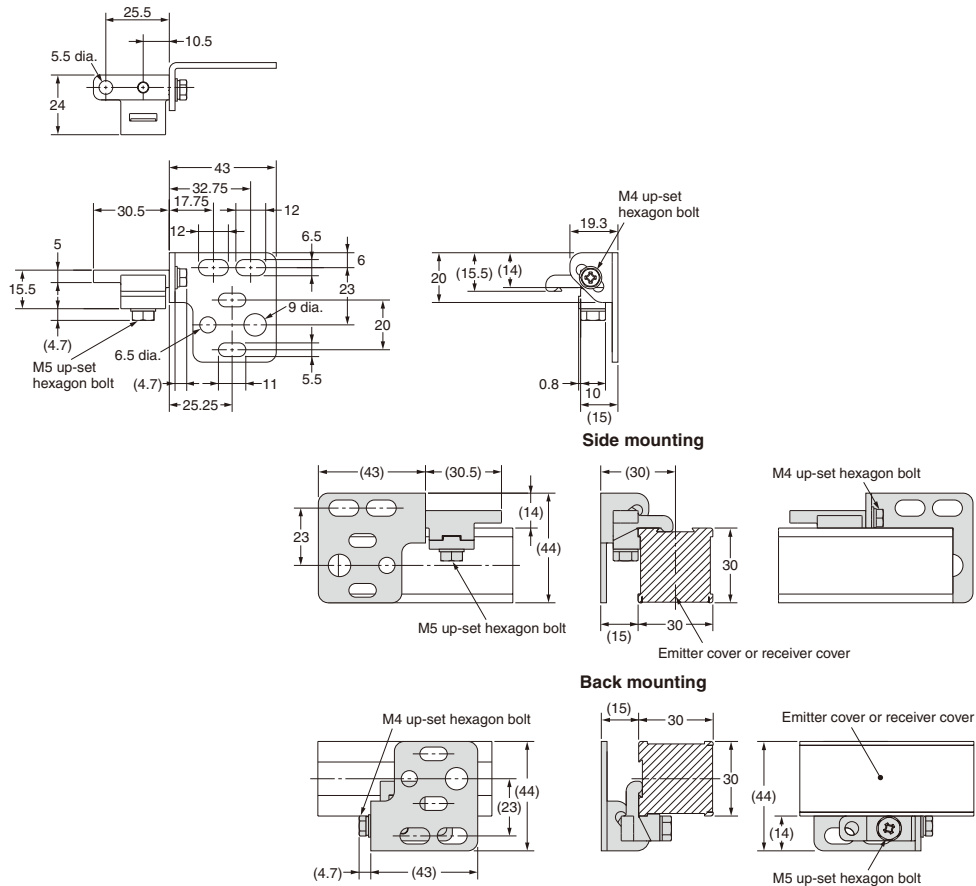

Connection Circuit Examples

An Example of Safety Circuits Where No Controller Is Used

For Category 4 Rating (F3SN-A, F3SH-A)/Category 2 Rating (F3SN-B)

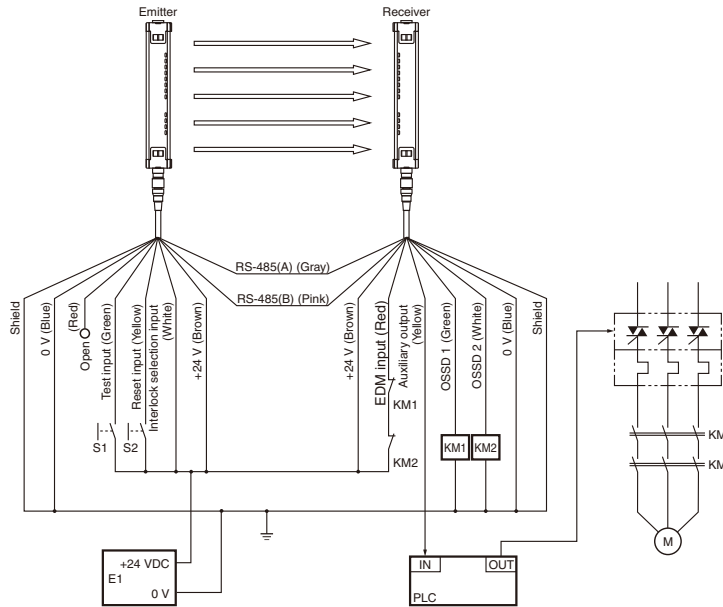

Applicable operation mode

- Manual reset mode
- Using the EDM function

- S1: External test switch
- S2: Interlock/lockout reset switch
- KM1, KM2: Safety relay with forcibly guided contacts (G7SA) or magnetic contactor
- KM3: Solid-state contactor (G3J)
- M: 3-phase motor
- E1: 24 VDC power supply (S82K)
- PLC: Programmable controller (Used for monitoring. This is not a part of a safety system.)

Timing Chart

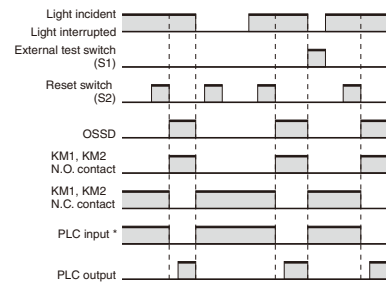

* The output operation mode of the auxiliary output is the Dark-ON output mode.

An Example of Safety Circuits Where the G9SA-301 Safety Relay Unit is Connected

For category 4 rating (F3SN-A, F3SH-A)/category 2 rating (F3SN-B)

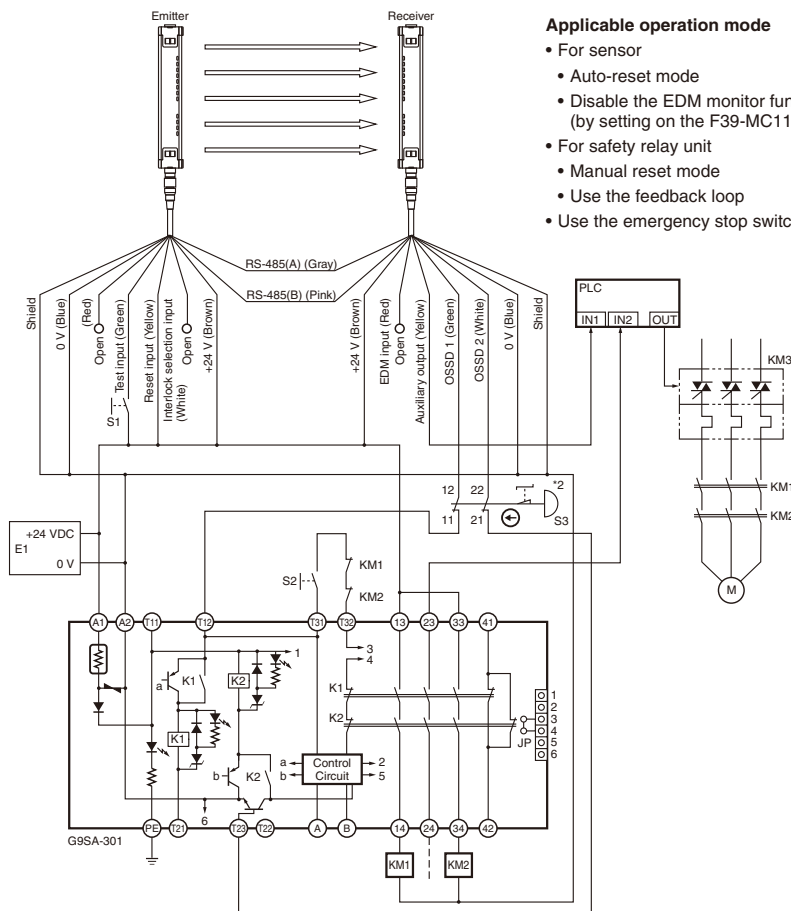

Applicable operation mode

- For sensor
- Auto-reset mode
- Disable the EDM monitor function (by setting on the F39-MC11, *1.)
- For safety relay unit
- Manual reset mode
- Use the feedback loop
- Use the emergency stop switch *2

- *1. The F39-MC11 setting console cannot be connected to the F3SN-B. Therefore, short-circuit the auxiliary output terminal and the EDM input.
- *2. If emergency stop switch is not necessary, connect the OSSD 1 directly to T12 terminal and connect the OSSD 2 directly to T23 terminal.

- S1: External test switch
- S2: Reset switch
- S3: Emergency stop switch (direct opening contacts) (A165E or A22E)
- KM1, KM2: Magnetic contactor
- KM3: Solid-state contactor (G3J)
- M: 3-phase motor
- E1: 24 VDC power supply (S82K)
- PLC: Programmable controller (Used for monitoring. This is not a part of a safety system.)

Timing Chart

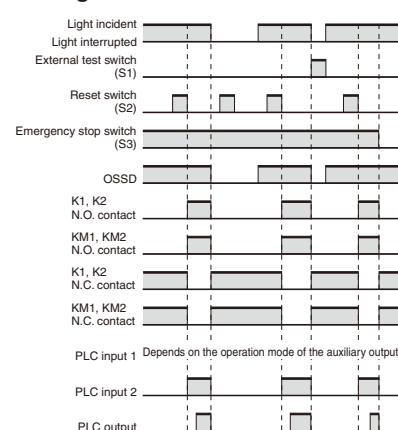

Examples of Safety Circuits Where G9SA-300-SC Safety Relay Unit is Connected

(1) For only safety light curtain in auto-reset mode
For category 4 rating (F3SN-A, F3SH-A)/category 2 rating (F3SN-B)

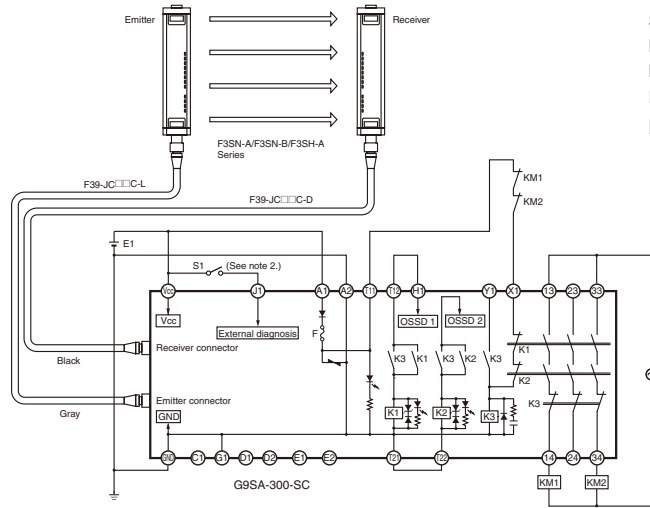

- S1: External test switch
- KM1, KM2: Magnetic contactor
- M: 3-phase motor
- E1: 24 VDC power supply (S82K)

- Note:**
1. F3SN-A's EDM function and auxiliary output cannot be used.
 2. Normal operation is performed when the switch S1 is released, and external diagnosis is performed when it is short-circuited.
 3. Do not connect anything to the C1, D1, D2, E1, and E2 terminals.

Timing Chart

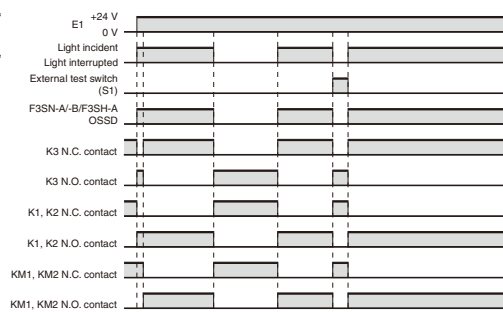

(2) Safety light curtain connected with two channel emergency stop switch inputs in manual reset mode
For category 4 rating (F3SN-A, F3SH-A)/category 2 rating (F3SN-B)

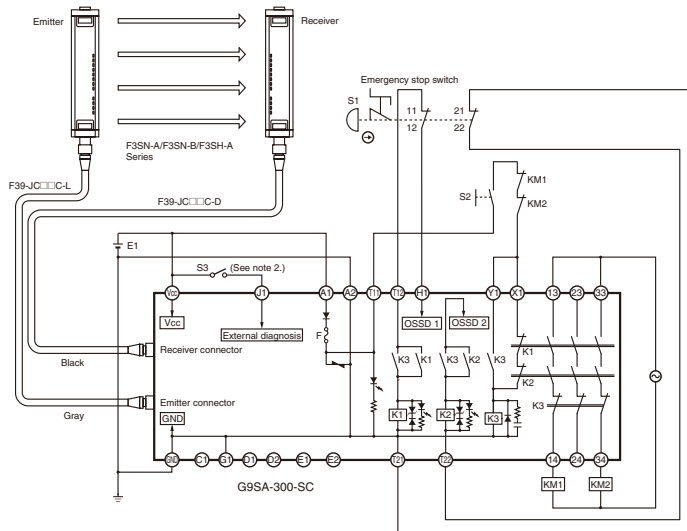

- S1: Emergency stop switch ☹
- S2: Reset switch (momentary action switch)
- S3: External test switch
- KM1, KM2: Magnetic contactor
- M: 3-phase motor
- E1: 24 VDC power supply (S82K)

- Note:**
1. F3SN-A's EDM function and auxiliary output cannot be used.
 2. Normal operation is performed when the switch S3 is released, and external diagnosis is performed when it is short-circuited.
 3. Do not connect anything to the C1, D1, D2, E1, and E2 terminals.

Timing Chart

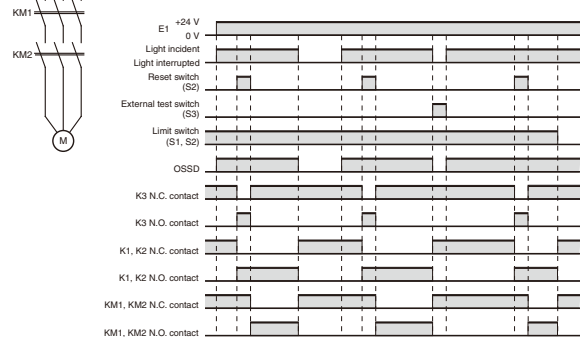

Safety Precautions

This catalog is intended as a guide for product selection. Be sure to use the instruction manual provided with the product for actual operation.

Regulations and Standards

F3SN-A/F3SH-A

- “Type Certification” specified in the Chapter 44. 2 of the Industrial Safety and Health Law in Japan does not apply to independent F3SN-A/F3SH-A Sensors. This law applies to systems incorporating the Sensor. When using the F3SN-A/F3SH-A Sensor in Japan as a “safety device for presses or shearing machines,” as specified in the Chapter 42 of the same law, apply for certification for the overall system.
 - (1) The F3SN-A/F3SH-A is electro-sensitive protective equipment (ESPE) in accordance with European Union (EU) Machinery Directive Annex IV, B, Safety Components, Item 1.
(2) The F3SN-A/F3SH-A complies with the following regulations and standards:
 - EU Regulations
 - Machinery Directive: Directive 98/37/EC
 - EMC Directive: Directive 89/336/EEC
 - European standards: EN61496-1 (TYPE 4 ESPE), prEN61496-2 (TYPE 4 AOPD)
 - International standards: IEC61496-1 (TYPE 4 ESPE), IEC61496-2 (TYPE 4 AOPD)
 - American standards: UL61496-1 (TYPE 4 ESPE), UL61496-2 (TYPE 4 AOPD), UL508, UL1998, CAN/CSA22.2 No. 14, CAN/CSA22.2 No. 0.8
 - JIS standards: JIS B9704-1 (TYPE 4 ESPE), JIS B9704-2 (TYPE 4 AOPD)
 - (3) The F3SN-A/F3SH-A received the following certification from the EU accredited body DEMKO A/S:
 - EC Type-Examination in accordance with the EU Machinery Directive (TYPE 4 ESPE)
 - Certificate of a competent body for EMC
 - DEMKO Type Certification
Type 4 ESPE (EN61496-1)
Type 4 AOPD (prEN61496-2)
 - (4) The F3SN-A/F3SH-A received the following certification from the Third Party Assessment Body UL:
 - Certificate of UL listing for US and Canadian safety standards
Both of which are: TYPE 4 ESPE (UL61496-1),
TYPE 4 AOPD (UL61496-2)
 - (5) The F3SN-A/F3SH-A received the following certification from BG-PRUFZERT of Germany:
 - BG test and certification mark
License
Type 4 ESPE (EN61496-1)
Type 4 AOPD (prEN61496-2)
3. The F3SN-A/F3SH-A is designed according to the following standards. To make sure that the F3SN-A/F3SH-A complies with the following standards and regulations, you are asked to design and use it as provided by any other related standards, laws, and regulations. (Underlined regulations are applicable to the F3SN-A only.)
Consult UL or other standardization bodies if you have any questions.
- EN415-4, prEN691, EN692, prEN693 (European standards)
 - OSHA 29 CFR 1910.212 (US Industrial Safety and Health Regulation)
 - OSHA 29 CFR 1910.217 (US Industrial Safety and Health Regulation)
 - ANSI B11.1 - B11.19 (US standard)
 - ANSI/RIA 15.06 (US standard)
 - Guideline Concerning Failsafe Methods for Control Mechanisms in Machine Tools, 28 July 1998 (The Announcement No. 464, Ministry of Health, Labour and Welfare)

F3SN-B

- “Type Certification” specified in the Chapter 44. 2 of the Industrial Safety and Health Law in Japan does not apply to independent units of the F3SN-B sensor. This law applies to systems incorporated with the sensors.
When using the F3SN-B sensor in Japan as a “safety device for presses or shearing machines” as specified in the Chapter 42 of the same law, apply for certification as a system.
 - (1) The F3SN-B is electro-sensitive protective equipment (ESPE) in accordance with European Union (EU) Machinery Directive Annex IV, B, Safety Components, Item 1.
(2) The F3SN-B complies with the following regulations and standards:
 - EU Regulations
 - Machinery Directive: Directive 98/37/EC
 - EMC Directive: Directive 89/336/EEC
 - European standards: EN61496-1 (TYPE 2 ESPE), prEN61496-2 (TYPE 2 AOPD)
 - International standards: IEC61496-1 (TYPE 2 ESPE), IEC61496-2 (TYPE 2 AOPD)
 - American standards: UL61496-1 (TYPE 2 ESPE), UL61496-2 (TYPE 2 AOPD), UL508, UL1998, CAN/CSA22.2 No. 14, CAN/CSA22.2 No. 0.8
 - JIS standards: JIS B9704-1 (TYPE 2 ESPE), JIS B9704-2 (TYPE 2 AOPD)
 - (3) The F3SN-B received the following certification from the EU accredited body DEMKO A/S:
 - EC Type-Examination in accordance with the EU Machinery Directive (TYPE 2 ESPE)
 - Certificate of a competent body for EMC
 - DEMKO Type Certification
Type 2 ESPE (EN61496-1)
Type 2 AOPD (prEN61496-2)
Use: EN954-1 Category B, 1, 2
 - (4) The F3SN-B received the following certification from the Third Party Assessment Body UL:
 - Certificate of UL listing for US and Canadian safety standards
Both of which are: Type 2 ESPE (UL61496-1),
Type 2 AOPD (UL61496-2)
 - (5) The F3SN-B received the following certification from BG-PRUFZERT of Germany:
 - BG test and certification mark
License
Type 2 ESPE (EN61496-1)
Type 2 AOPD (prEN61496-2)
3. The F3SN-B is designed according to the following standards. To make sure that the F3SN-B complies with the following standards and regulations, you are asked to design and use it as provided by any other related standards, laws, and regulations.
Consult UL or other standardization bodies if you have any questions.
- EN415-4 (European standard)
 - OSHA 29 CFR 1910.212 (US Industrial Safety and Health Regulation)
 - ANSI/RIA 15.06 (US standard)
 - Guideline Concerning Failsafe Methods for Control Mechanisms in Machine Tools, 28 September 1998 (The Announcement No. 464, Ministry of Health, Labour and Welfare)

⚠ WARNING**Detection Zone and Intrusion Path**

Refer to "Precautions for All Safety Sensors" for the installation conditions of Safety Light Curtains.

F3SH-A Multi-beam Safety Sensor

Install protective structures around the machine so that you must pass through the detection zone of the F3SH-A to reach a hazardous part of the machine.

If it is possible for an operator to get between the sensor's detection zone and the hazardous part of the machine, design the system so that machinery cannot start up automatically. Make sure that machinery cannot restart while the operator is in the hazardous area. Position the switch for restarting machinery in a location from which the status of the hazardous area can be seen clearly. The switch position location must be a place where the switch cannot be operated from within the hazardous area. Failure to do so may result in serious injury.

**· Use of the Fixed Blanking Function (F3SN-A only)**

After setting the fixed blanking, check that the F3SN-A detects a test rod at any position in the detection zone through which a person can reach the hazardous part of the machine. If any positions are found by check above, install protective structures to prevent intrusion, which the F3SN-A can not detect.

Failure to do so may result in serious injury.

**Safety Distance**

Always maintain a safe distance (S) between the light curtain and a hazardous part of a machine.

Failure to do so causes the machine to fail to stop before an operator reaches the dangerous area and may result in serious injury.



Use of the floating blanking increases the size of the detection capability. To calculate a safety distance, be sure to use the increased size of the detection capability. Failure to do so causes the machine to fail to stop before an operator reaches the dangerous area and may result in serious injury.



F3SN-A/F3SN-B Safety Light Curtains

<Reference>

Method for calculating safety distance as provided by International Standard ISO 13855-2002 (European Standard EN 999-1999) (for intrusion perpendicular to the detection zone)

System that has detection capability of 40 mm max.

Substitute $K = 2,000 \text{ mm/s}$ and $C = 8 (d - 14 \text{ mm})$ in equation (1) and calculate as shown below.

$$S = 2,000 \text{ mm/s} \times (T_m + T_s) + 8 (d - 14 \text{ mm}) \dots\dots\dots (2)$$

Where: S = Safety distance (mm)

T_m = Machine response time (s) *1

T_s = Light curtain response time (s) *2

d = Detection capability of the light curtain (mm)

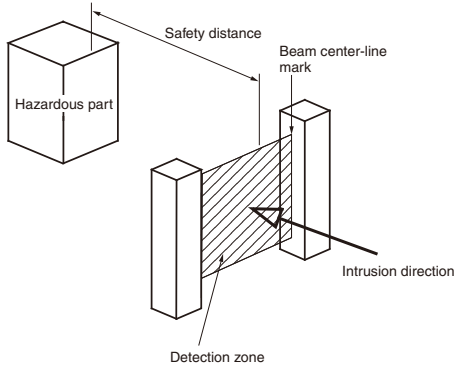

Example:

$T_m = 0.05 \text{ s}$, $T_s = 0.01 \text{ s}$, $d = 14 \text{ mm}$:

$$S = 2,000 \text{ mm/s} \times (0.05 \text{ s} + 0.01 \text{ s}) + 8 (14 \text{ mm} - 14 \text{ mm}) = 120 \text{ mm}$$

Use $S = 100 \text{ mm}$ if the result of equation (2) is less than 100 mm. Recalculate using the following equation with $K = 1,600 \text{ mm/s}$ if the result is over 500 mm.

$$S = 1,600 \text{ mm/s} \times (T_m + T_s) + 8 (d - 14 \text{ mm}) \dots\dots\dots (3)$$

Use $S = 500 \text{ mm}$ if the result from equation (3) is less than 500 mm.

Systems with a Smallest Detectable Object Size (Diameter) Greater than 40 mm

Substitute $K = 1,600 \text{ mm/s}$ and $C = 850 \text{ mm}$ in equation (1) and calculate as shown below.

$$S = 1,600 \text{ mm/s} \times (T_m + T_s) + 850$$

Where: S = Safety distance (mm)

T_m = Machine response time (s) *1

T_s = Light curtain response time (s) *2

Example:

$T_m = 0.05 \text{ s}$, $T_s = 0.01 \text{ s}$:

$$S = 1,600 \text{ mm/s} \times (0.05 \text{ s} + 0.01 \text{ s}) + 850 \text{ mm} = 946 \text{ mm}$$

*1. The machine response time refers to the maximum time from the moment the machine receives a stop signal to the moment the hazardous part of the machine stops. The machine response time should be measured on actual machines. The machine response time should be measured and confirmed periodically.

*2. The light curtain response time refers to the time required for output to change from ON to OFF.

Response Time Table

Model	Protective height (mm)	Number of beams	Response time	
			ON to OFF	OFF to ON
F3SNA□□□□ P14(-01)	180 to 450	20 to 50	10.0	40
	459 to 765	51 to 85	12.5	50
	774 to 1,080	86 to 120	15.0	60
	1,089 to 1,125	121 to 125	15.5	62

Model	Protective height (mm)	Number of beams	Response time	
			ON to OFF	OFF to ON
F3SN-A□□□□ P25(-01)	217 to 772	13 to 50	10.0	40
	787 to 1,297	51 to 85	12.5	50
F3SN-B□□□□ P25	1,312 to 1,822	86 to 120	15.0	60

Model	Protective height (mm)	Number of beams	Response time	
			ON to OFF	OFF to ON
F3SN-A□□□□ P40(-01)	217 to 757	7 to 25	10.0	40
	787 to 1,297	26 to 43	12.5	50
F3SN-B□□□□ P40	1,327 to 1,807	44 to 60	15.0	60

Model	Protective height (mm)	Number of beams	Response time	
			ON to OFF	OFF to ON
F3SN-A□□□□ P70(-01)	277 to 757	5 to 13	10.0	40
	817 to 1,297	14 to 22	12.5	50
F3SN-B□□□□ P70	1,357 to 1,777	23 to 30	15.0	60

• Response time for series connected types is calculated as follows: (F3SN-A)

For 2 sets:

Response time (ON to OFF): Response time of Light curtain 1 +

Response time of Light curtain 2 + 3 ms

Response time (OFF to ON): Response time of Light curtain 1 +

Response time of Light curtain 2 + 12 ms

For 3 sets:

Response time (ON to OFF): Response time of Light curtain 1 +

Response time of Light curtain 2 + Response time of Light curtain 3 + 4 ms

Response time (OFF to ON): Response time of Light curtain 1 +

Response time of Light curtain 2 + Response time of Light curtain 3 + 16 ms

• Response time of F3SP-B1P is 10 ms, operation time is 100 ms.

Note: When using the F3SP-B1P, determine the safety distance by adding the response time of the F3SP-B1P to that of the F3SN given in the table above.

<Reference>**Method for calculating the safety distance as provided by ANSI B11. 19 (US)**

Safety distance (S) = Intrusion speed into the detection zone (K)
Response time (Ts + Tc + Tr + Tbm) + Additional distance (Dpf)

Where:

K = Intrusion speed (Recommended value in OSHA standards is 1,600 mm/s)

ANSI B11. 19. does not define Intrusion speed (K). When determining K, consider possible factors including physical ability of operators.

Ts = Time required for machine to stop (s)

Tr = Light curtain response time (s) *

Tc = Maximum response time required for machine control circuit to apply brake (s)

Tbm = Additional time (s)

If the machine is provided with a brake monitor, Tbm = brake monitor setting time – (Ts + Tc). If not provided with a brake monitor, it is recommended to determine a value more than 20% of (Ts + Tc) as the additional time.

Dpf = Additional distance. Dpf is calculated as follows based on ANSI standards.

$$Dpf = 3.4 \times (d - 7.0)$$

: d is the detection capability of the light curtain (mm).

Example:

Assume that: K = 1,600 mm/s, Ts + Tc = 0.06 s,

Brake monitor setting time = 0.1s, Tr = 0.01s, d = 14 mm.

Then:

$$Tbm = 0.1 - 0.06 = 0.04 \text{ s}$$

$$Dpf = 3.4 - (14 - 7.0) = 23.8 \text{ mm}$$

$$S = 1,600 \times (0.06 + 0.01 - 0.04) + 23.8 = 199.8 \text{ mm}$$

* The light curtain response time refers to the time required for output to change from ON to OFF.

<Reference>**Method for calculating the safety distance as provided by ANSI/RIA R15.06 (US) (for intrusion perpendicular to the detection zone)**

Safety distance (Ds) = K × (Ts + Tc + Tr) + Dpf

Where:

K = Intrusion speed: 1,600 mm/s min.

Ts = Maximum stop time of machine/equipment (s)

Tc = Maximum stop time of control system (s)

Tr = Light curtain response time (s) *

Os = Diameter of the smallest detectable object (mm)

Dpf = Additional distance (mm)

Assume that the sensor is installed with the lowest beam height above the floor at 300 mm and the highest beam height above the floor at 1,200 mm, with the diameter of the smallest detectable object being 64 mm or less. Then, Dpf is determined from:

$$Dpf = 3.4 \times (Os - 6.875 \text{ mm}).$$

If the diameter of the smallest detectable object is more than 64 mm, Dpf is calculated to be 900 mm.

Example:

- F3SN-B□□□□P40 Safety Light Curtain

Assume that K = 1,600 mm/s, Ts + Tc = 0.06 s, Tr = 0.01 s, and Os = 40 mm.

Then:

$$\begin{aligned} S &= 1,600 \times (0.06 + 0.01) + Dpf \\ &= 1,600 \times (0.06 + 0.01) + 3.4 (40 - 6.875) \\ &= 225 \text{ mm} \end{aligned}$$

- F3SN-B□□□□P70 Safety Light Curtain

Assume that K = 1,600 mm/s, Ts + Tc = 0.06 s, Tr = 0.01 s, and Dpf = 900 mm.

Then:

$$\begin{aligned} S &= 1,600 \times (0.06 + 0.01) + 900 \\ &= 1,012 \text{ mm} \end{aligned}$$

* The light curtain response time refers to the time required for output to change from ON to OFF.

F3SH-A Multi-beam Safety Sensors**<Reference>****Method for calculating safety distance as provided by European Norm EN999 (for intrusion perpendicular to the detection zone)**

Substitute K = 1,600 mm/s and C = 850 mm in equation (1) and calculate as shown below.

$$S = 1,600 \text{ mm/s} \times (Tm + Ts) + 850$$

Where:

S = Safety distance (mm)

Tm = Machine response time (s) *1

Ts = Sensor response time (s) *2

Example:

Tm = 0.05 s, Ts = 0.01 s:

$$S = 1,600 \text{ mm/s} \times (0.05 \text{ s} + 0.01 \text{ s}) + 850 \text{ mm} = 946 \text{ mm}$$

*1. The machine response time refers to the maximum time from the moment the machine receives a stop signal to the moment the hazardous part of the machine stops. The machine response time should be measured on actual machines. The machine response time should be measured and confirmed periodically.

*2. The sensor response time refers to the time required for output to change from ON to OFF.

Precautions for Correct Use

Do not use the product in atmospheres or environments that exceed product ratings.

Installation

How to Prevent Mutual Interference

Series connection (Up to 3 sets, 240 beams, sensor models ending in -01, -03, -04, and -05 are required for series connection)

Two or more pairs of the F3SN-A can be connected in series. When connected in series, the F3SN-A sensors generate beams in a time-sharing manner. Thus, they prevent mutual interference and ensure safety.

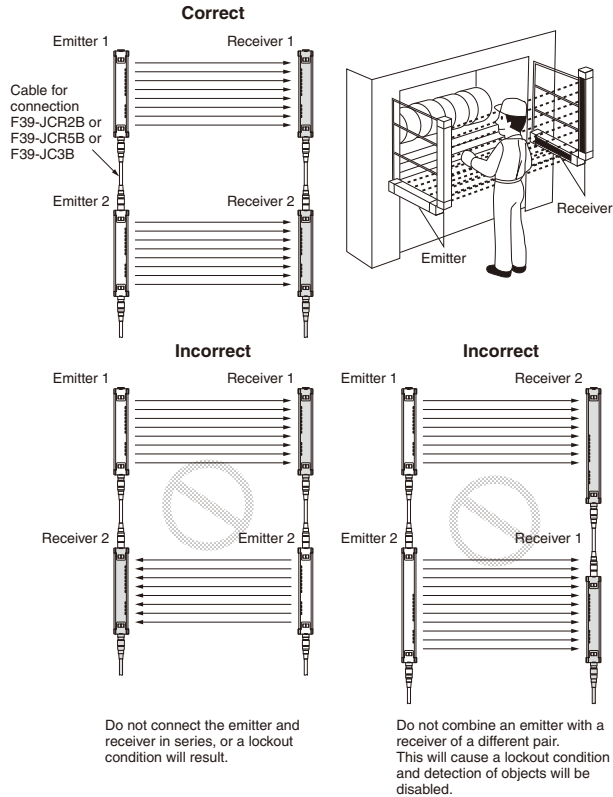

When not connected

Refer to "Precautions for All Safety Sensors" for information on preventing mutual interference of Safety Light Curtains that are not connected in series.

Installation

How to attach Mounting Bracket (F39-L19/L20)

To fully utilize the performance of sensors, locate the F39-L19/L20 mounting brackets in the number satisfying the dimensions "A" and "B" in the sensor longitudinal direction.

- For the F39-L19 Spacing "A": 670 mm max.
- For the F39-L20 Spacing "B": 400 mm max.

Note: When installing sensors at locations susceptible to vibration and shock, increase the number of mounting brackets.

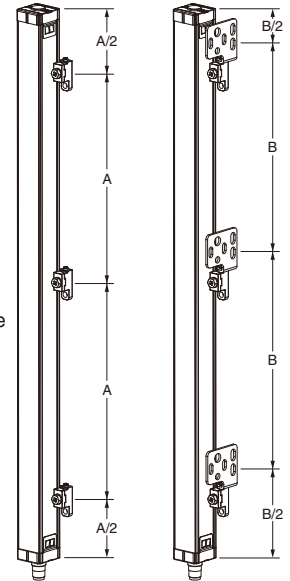

Mounting bracket	Screw × length (mm)	Tightening torque
F39-L19	M5 × 12 screw	2.0 N·m
F39-L20	M4 × 8 screw	1.2 N·m

F39-L19

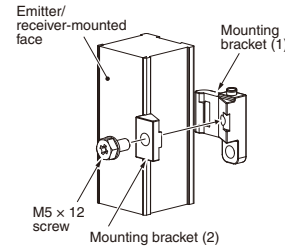

Brackets and screws included in one set

- Mounting bracket (1)1
- Mounting bracket (2)1
- M5 × 12 screw1

F39-L20

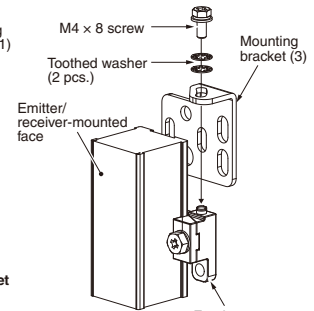

[Brackets (1) and (2), M5 × 12 screw]

Brackets and screws included in one set

- Mounting bracket (1)1
- Mounting bracket (2)1
- M5 × 12 screw1
- Mounting bracket (3)1
- M4 × 8 screw1
- Toothed washer2

Safety-related Functions

Interlock Function

The auto-reset mode and the manual reset mode are wire selectable features of the F3SN-A/F3SN-B/F3SH-A.

Auto-reset Mode

After the power is turned ON and none of the beams are interrupted, the OSSD (Output Signal Switching Device) outputs will go to their ON-state.

Manual Reset Mode

For the factory setting, the start/restart interlock is selected in the manual reset mode. When the light curtain enters the interlock condition, it keeps the OSSD outputs in the OFF-state. Even if all beams become free, the OSSD outputs will not go to the ON-state. When none of the beams are interrupted in the detection zone, applying the reset input resets the interlock condition and the OSSD outputs go to the ON-state.

- Start/restart interlock
After the power is turned ON, or when at least one beam is interrupted, the light curtain enters the interlock condition.
- Start interlock
Only after power ON, the light curtain enters the interlock condition.
- Restart interlock
Only when at least one beam is interrupted, the light curtain enters the interlock condition.

Diagnostic Functions

Self-test

After power ON, the F3SN-A/F3SN-B/F3SH-A performs a complete self-test within 1 second. In addition, it performs a self-test (within response time) periodically during operation.

External Test

This function stops the emission of light from the light curtain using an external signal and checks that the light curtain operates properly.

Lockout Condition

If an error is detected by the self-test, the light curtain enters the lockout condition, keeps the OSSD outputs in their OFF state and displays the error mode. Lockout condition can be cleared either by resetting the power or by changing the setting of the reset switch from closed to open (open to closed for auto-reset). (With some errors, the lockout condition is automatically reset when the light curtain confirms that the cause of the error has been removed.)

Fixed Blanking Function (F3SN-A only)

This function is set with the F39-MC11 setting console. This is a function provided to disable a specific area of the light curtain's detection zone. Fixed blanking can be set for any desired number of beams. If an object enters the disabled detection zone, the OSSD outputs status will not change. This function is used when there is a stationary object in the detection zone that needs to be ignored.

Floating Blanking Function (F3SN-A only)

This function is set with the F39-MC11 setting console. During normal operation when floating blanking is disabled, and at least one beam is interrupted, the light curtain will go to the OFF-state. However, using this function prevents the light curtain from going to the OFF-state until multiple beams (*1, *2, and *3) are interrupted.

- *1. The number of the floating blanking beams can be selected in the range of 1 to 3 beams.
- *2. This function can be set to be active only if the interrupted beams are adjacent to each other.
- *3. This function can be set so that the top and bottom beams cannot be set for the function.

EDM (External Device Monitoring)

This function monitors the state of the NC contacts. Connect the NC contact of the MPCEs to the EDM input line of the receiver. If the correct logical relationship between the OSSD outputs and the EDM input is not kept, the light curtain immediately enters the lockout condition and the OSSD outputs will go to their OFF-state. The light curtain's normal operation is up to 300 ms max. (*), this allows for the delay time caused by the release of the MPCEs. To ensure the correct usage of this function, the MPCEs must be safety-certified types with forcibly guided contacts.

When the EDM is not used

In the case the EDM input is not used, connect the auxiliary output in the Dark-ON output mode to the EDM input line, or disable the EDM with the F39-MC11 setting console.

- * The value can be changed by the F39-MC11.
(It is impossible to connect the F39-MC11 to the F3SN-B.)

Non-safety Output

Auxiliary Output

The default of this output is the reverse signal of the safety outputs (Dark-ON output). This output can be used for monitoring purposes by connecting it to a device such as a PLC.

The auxiliary output can be selected to give one of the following output operation modes by the F39-MC11. (No selection can be made by the F3SN-B.)

- Dark-ON output mode (fixed for the F3SN-B)
- Light-ON output mode
- Light diagnosis mode
- Lockout mode
- Outermost-beam monitoring mode
- Specified-beam mode
- Blanking monitoring mode (F3SN-A only)

External Indicator Output (Series-connection type only)

This output can be connected to an external indicator to display one of the operation modes as selected by the F39-MC11. The default of this output is Light-ON output. A desired output operation mode can be selected by using the F39-MC11.

Beam Center-line

The beam center-line is the line going through all of the beams. (See diagram below.) This position is a reference line for measuring safety distance. Use the line closer to the hazardous area as a reference line for the safety distance.

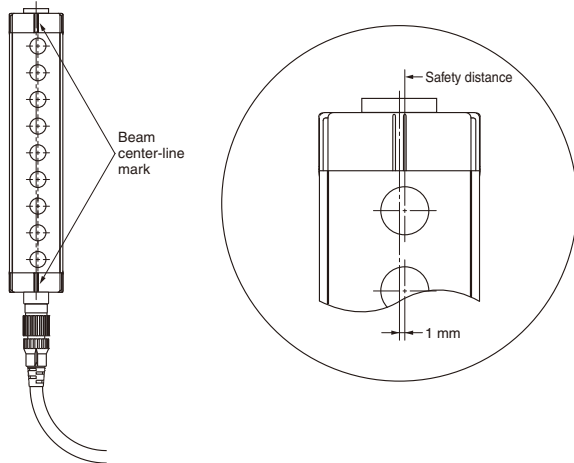

Precautions for All Safety Sensors

Note: Refer to the “*Safety Precautions*” section for each Sensor for specific precautions applicable to each Sensor.

⚠ WARNING

Installation Conditions

Detection Zone and Intrusion Path

Install a protective structure so that the hazardous part of a machine can only be reached by passing through the sensor's detection zone. Install the sensors so that part of the person is always present in the detection zone when working in a machine's hazardous areas. If a person is able to step into the hazardous area of a machine and remain behind the Safety Light Curtain's detection zone, configure the system with an interlock function that prevents the machine from being restarted. Otherwise it may result in heavy injury.



Correct Installation

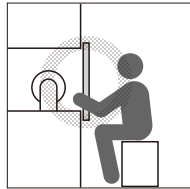

A person can only reach the hazardous part of the machinery by passing through the sensor's detection zone.

Correct Installation

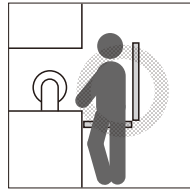

A person enters the detection zone during operation.

Incorrect Installation



A person can reach the hazardous part of the machinery without passing through the sensor's detection zone.

Incorrect Installation

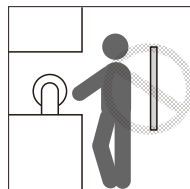

A person is between the sensor's detection zone and the hazardous part of the machinery.

Install the interlock reset switch in a location that provides a clear view of the entire hazardous area and where it cannot be activated from within the hazardous area.



The Safety Light Curtain cannot protect a person from an object flying from a hazardous area. Install protective cover(s) or fence(s).



Safety Distance

The safety distance is the distance that must be set between the Safety Light Curtain and a machine's hazardous part to stop the hazardous part before a person or object reaches it. The safety distance varies according to the standards of each country and the individual specifications of each machine. In addition, the calculation of the safety distance differs if the direction of approach is not perpendicular to the detection zone of the Safety Light Curtain. Always refer to relevant standards.

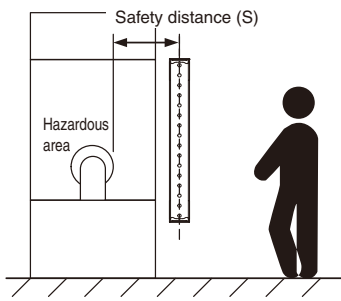

Make sure to secure the safety distance (S) between the Safety Light Curtain and the hazardous part. Otherwise, the machine may not stop before a person reaches the hazardous part, resulting in serious injury.



Note: The response time of a machine is the time period from when the machine receives a stop signal to when the machine's hazardous part stops.

Measure the response time on the actual system. Also, periodically check that the response time of the machine has not changed.

How to calculate the safety distance specified by International standard ISO13855-2002 (European standard EN999-1999) (Reference)

If a person approaches the detection zone of the Safety Light Curtain perpendicularly, calculate the safety distance as shown below.

$$S = K \times T + C \dots \text{Eq. (1)}$$

- S: Safety distance
- K: Approach speed to the detection zone
- T: Total response time of the machine and Safety Light Curtain
- C: Additional distance calculated by the detection capability of the Safety Light Curtain

<System that has detection capability of 40 mm max.>

Use $K = 2,000 \text{ mm/s}$ and $C = 8 \times (d - 14 \text{ mm})$ in equation (1) for the calculation.

$$S = 2,000 \text{ mm/s} \times (T_m + T_s) + 8 \times (d - 14 \text{ mm})$$

- S = Safety distance (mm)
- T_m = Machine's response time (s)
- T_s = Response time of the Safety Light Curtain from ON to OFF (s) *
- d = Size of Safety Light Curtain's detection capability (mm) *

* These values differ depending on the Switch. Refer to the “*Precautions for Correct Use*” for the Switch you are using.

[Calculation example]

When $T_m = 0.05 \text{ s}$, $T_s = 0.01 \text{ s}$, and $d = 14 \text{ mm}$:

$$S = 2,000 \text{ mm/s} \times (0.05 \text{ s} + 0.01 \text{ s}) + 8 \times (14 \text{ mm} - 14 \text{ mm}) = 120 \text{ mm} \dots \text{Eq. (2)}$$

If the result is less than 100 mm, use $S = 100 \text{ mm}$.

If the result exceeds 500 mm, use the following equation where $K = 1,600 \text{ mm/s}$.

$$S = 1,600 \text{ mm/s} \times (T_m + T_s) + 8 \times (d - 14 \text{ mm}) \dots \text{Eq. (3)}$$

If the result of this Eq. (3) is less than 500 mm,

use $S = 500 \text{ mm}$.

<Systems with a Smallest Detectable Object Size (Diameter) Greater than 40 mm or Systems Using Multi-beam Safety Sensors>

Assuming $K = 1,600$ mm/s and $C = 850$ mm, the following calculation is made using Eq. (1).

$$S = 1,600 \text{ mm/s} \times (T_m + T_s) + 850 \dots \text{Eq. 4,}$$

- S = Safety distance (mm)
- T_m = Machine's response time (s)
- T_s = Response time of the Safety Light Curtain from ON to OFF (s)

Calculation example:

When $T_m = 0.05$ s and $T_s = 0.01$ s,

$$S = 1,600 \text{ mm/s} \times (0.05 \text{ s} + 0.01 \text{ s}) + 850 \text{ mm} = 946 \text{ mm}$$

How to calculate the safety distance specified by American standard ANSI B11.19 (Reference)

<Systems with a Smallest Detectable Object Size (Diameter) Less than 64 mm>

If a person approaches the detection zone of the Safety Light Curtain perpendicularly, calculate the safety distance as shown below.

$$S = K \times (T_s + T_c + T_r + T_{bm}) + D_{pf}$$

- S : Safety distance
- K : Approach speed to the detection zone (the value recommended by OSHA standard is 1,600 mm/s)

Approach speed K is not specified in the ANSI B.11.19 standard. To determine the value of K to apply, consider all factors, including the operator's physical ability.

- T_s = Machine's stop time (s)
- T_r = Response time of the Safety Light Curtain from ON to OFF (s)
- T_c = Machine control circuit's maximum response time required to activate its brake (s)
- T_{bm} = Additional time (s)

If a machine has a brake monitor, " T_{bm} = Brake monitor setting time - ($T_s + T_c$)". If it has no brake monitor, we recommend using 20% or more of ($T_s + T_c$) as additional time.

- D_{pf} = Additional distance

According to ANSI's formula, D_{pf} is calculated as shown below:

$D_{pf} = 3.4 \times (d - 7.0)$: Where d is the detection capability of the Safety Light Curtain (unit: mm)

[Calculation example]

When $K = 1,600$ mm/s, $T_s + T_c = 0.06$ s, brake monitor setting time = 0.1 s, $T_r = 0.01$ s, $d = 14$ mm:

$$T_{bm} = 0.1 - 0.06 = 0.04 \text{ s}$$

$$D_{pf} = 3.4 \times (14 - 7.0) = 23.8 \text{ mm}$$

$$S = 1,600 \times (0.06 + 0.01 + 0.04) + 23.8 = 199.8 \text{ mm}$$

Method for Calculating the Safety Distance as Provided by ANSI/RIA R15.06 (USA) (Reference)

<Systems with a Smallest Detectable Object Size (Diameter) Greater than 64 mm and Less than 600mm>

The safety distance is calculated based on the following concepts when the human body intrudes perpendicular to the detection zone of the Safety Light Curtain.

$$S = K \times (T_s + T_c + T_r) + D_{pf}$$

- S : Safety distance
- K = Intrusion speed into detection zone (1,600 mm/s min. recommended by OSHA)
- T_s = Stop time of machine/equipment (s)
- T_r = Light curtain ON-to-OFF response time (s)
- T_c = Maximum response time of the machine/equipment braking circuit required to operate the brake (s)
- D_{pf} = Additional distance (mm)

If the Sensor is installed with the lowest beam height above the floor at 300 mm or lower and the highest beam height above the floor at 1,200 mm or higher, the D_{pf} will be 900 mm.

If the Sensor is installed with the lowest beam height above the floor at 300 mm or lower and the highest beam height above the floor at 900 mm or higher, the D_{pf} will be 1,200 mm.

[Calculation example]

$$K = 1,600 \text{ mm/s, } T_s + T_c = 0.06 \text{ s,}$$

If $T_r = 0.01$ s and $D_{pf} = 900$ mm:

$$S = 1,600 \times (0.06 + 0.01) + 900 = 1,012 \text{ mm}$$

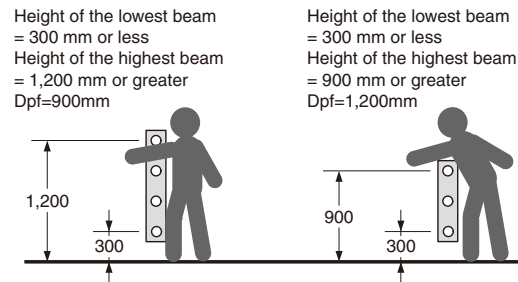

Distance from Glossy Surface

Install the sensor system so that it is not affected by reflection from a glossy surface. Failure to do so may hinder detection, resulting in serious injury.



Install the sensor system at distance D or further from highly reflective surfaces such as metallic walls, floors, ceilings, or workpieces, as shown below.

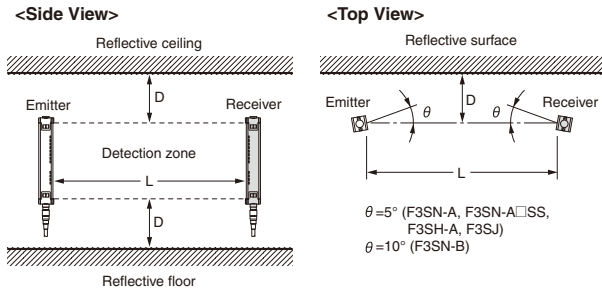

Distance between emitter and receiver (Detection Distance)	Allowable installation distance D	
	Type 4	Type 2
For 0.2 to 3 m	0.13 m	0.26 m
For 3 m or more	$L/2 \times \tan 5^\circ$ $= L \times 0.044$ (m)	$L/2 \times \tan 10^\circ$ $= L \times 0.088$ (m)

Others

To use the Safety Light Curtain in PSDI mode (restart of cycle operation by the sensor), you must configure an appropriate circuit between the Safety Light Curtain and the machine. For details about PSDI, refer to OSHA1910.217, IEC61496-1, and other relevant standards and regulations.



Do not try to disassemble, repair, or modify this product. Doing so may cause the safety functions to stop working properly.



Do not use the Safety Light Curtain in environments where flammable or explosive gases are present. Doing so may result in explosion.



Perform daily and 6-month inspections for the Safety Light Curtain. Otherwise, the system may fail to work properly, resulting in serious injury.



Installation

Prevention of Mutual Interference

The emitter and the receiver to be set facing each other should be a pair of the same set. Erroneous combination may create a zone where objects cannot be detected.



Do not use a sensor system in a reflective configuration. Doing so may hinder detection. Mirrors can be used change the optical route.



When using more than 1 set of Safety Light Curtain, install them so that mutual interference does not occur, such as by configuring series connections or using physical barriers between adjacent sets.



Precautions for Safe Use

Do not use the product in atmospheres or environments that exceed product ratings

Installation

Prevention of Mutual Interference

For series connection

Refer to the "Precautions for Correct Use" for individual models for information on preventing mutual interference of linkable Safety Light Curtains.

For no series connection

When installing two or more pairs of light curtains independently from each other due to inconvenience of wiring or other reason, take proper measures to prevent mutual interference. If mutual interference occurs, a lockout condition will result for the Safety Light Curtain.

- Installation which may cause mutual interference

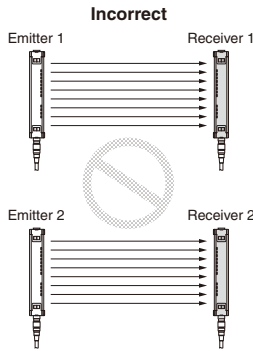
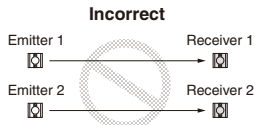
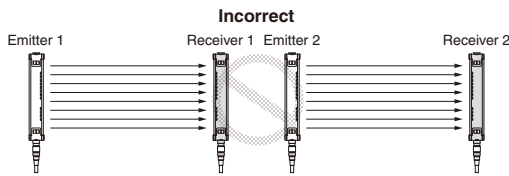

- Installation to prevent mutual interference
- (1) Install so that the two light curtains emit in the opposite directions (staggered).

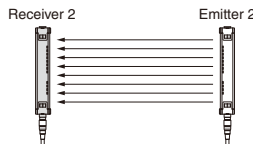
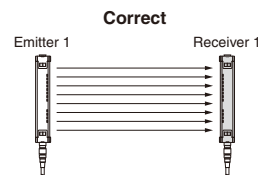
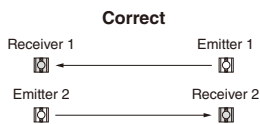
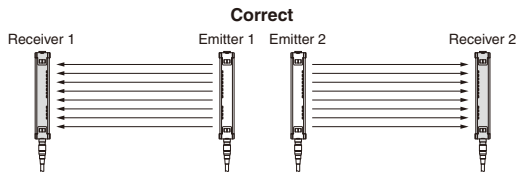

- (2) Install a light interrupting wall in between sensors.

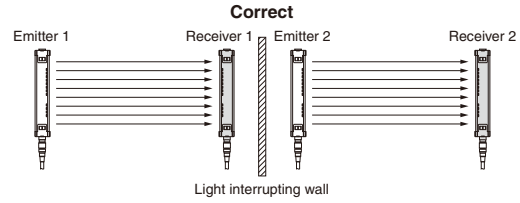

- (3) Install the light curtains facing away from the one another to eliminate mutual interference.

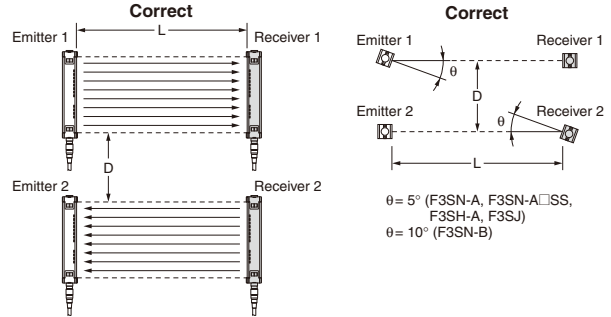

Distance between emitter and receiver (Detection Distance)	Allowable installation distance D	
	Type 4	Type 2
For 0.2 to 3 m	0.26 m	0.52 m
For 3 m or more	$L \times \tan 5^\circ$ = $L \times 0.088$ (m)	$L \times \tan 10^\circ$ = $L \times 0.18$ (m)

Operating range

Chattering may occur in the output when the distance between the emitter and the receiver is less than 0.2 m. Use only in the rated operating range.

- (4) Use a spatter protection slit cover. (F3SN and F3SH)
- (5) Shorten the detection distance by setting with a setting tool. (F3SJ)

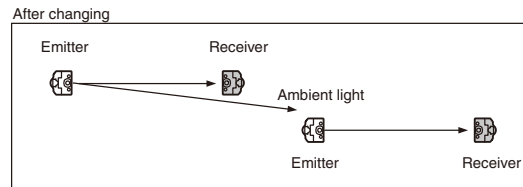
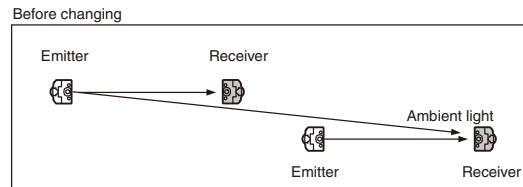



WARNING

This catalog is a guide to help customers select the proper safety products. Observe the following items when choosing products, select the right products for your devices or equipment, and develop a safety-related system to fully utilize product functions.

Setting Up a Risk Assessment System

The items listed in this catalog must be used properly in terms of product location as well as product performance and functionality. Part of the process of selecting and using these products should include the introduction and development of a risk assessment system early in the design development stage to help identify potential dangers in your equipment that will optimize safety product selection. A badly designed risk assessment system often results in poor choices when it comes to safety products.

- Related International Standards:
ISO 14121 Principles of Risk Assessment

Safety Policy

When developing a safety system for the devices and equipment that use safety products, make every effort to understand and conform to the entire series of international and industrial standards available, such as the examples given below.

- Related International Standards:
ISO 12100 Basic Concepts, General Principles for Design
IEC 61508 Functional Safety of Electrical/Electronic/Programmable Electronic Safety-related Systems

Role of Safety Products

Safety products have functions and mechanisms that ensure safety as defined by standards. These functions and mechanisms are designed to attain their full potential within safety-related systems. Make sure you fully understand all functions and mechanisms, and use that understanding to develop systems that will ensure optimal usage.

- Related International Standards:
ISO 14119 Interlocking Devices Associated with Guards-Principles for Design and Selection

Installing Safety Products

Make sure that properly educated and trained engineers are selected to develop your safety-related system and to install safety products in devices and equipment.

- Related International Standards:
ISO 12100 Basic Concepts, General Principles for Design
IEC 61508 Functional Safety of Electrical/Electronic/Programmable Electronic Safety-related Systems

Observing Laws and Regulations

Safety products should conform to pertinent laws, regulations, and standards, but make sure that they are used in accordance with the laws, regulations, and standards of the country where the devices and equipment incorporating these products are distributed.

- Related International Standards:
IEC 60204 Electrical Equipment of Machines

Observing Usage Precautions

Carefully read the specifications and precautions listed in this catalog for your product as well as all items in the Operating Manual packed with the product to learn usage procedures that will optimize your choice. Any deviation from precautions will lead to unexpected device or equipment failure not anticipated by safety-related systems or fire originating from equipment failure.

Transferring Devices and Equipment

When transferring devices and equipment, be sure to keep one copy of the Operating Manual and pack another copy with the device or equipment so the person receiving it will have no problem operating it.

- Related International Standards:
ISO 12100 Basic Concepts, General Principles for Design
IEC 61508 Functional Safety of Electrical/Electronic/Programmable Electronic Safety-related Systems

Read and Understand This Catalog

Please read and understand this catalog before purchasing the products. Please consult your OMRON representative if you have any questions or comments.

Warranty and Limitations of Liability

WARRANTY

OMRON's exclusive warranty is that the products are free from defects in materials and workmanship for a period of one year (or other period if specified) from date of sale by OMRON.

OMRON MAKES NO WARRANTY OR REPRESENTATION, EXPRESS OR IMPLIED, REGARDING NON-INFRINGEMENT, MERCHANTABILITY, OR FITNESS FOR PARTICULAR PURPOSE OF THE PRODUCTS. ANY BUYER OR USER ACKNOWLEDGES THAT THE BUYER OR USER ALONE HAS DETERMINED THAT THE PRODUCTS WILL SUITABLY MEET THE REQUIREMENTS OF THEIR INTENDED USE. OMRON DISCLAIMS ALL OTHER WARRANTIES, EXPRESS OR IMPLIED.

LIMITATIONS OF LIABILITY

OMRON SHALL NOT BE RESPONSIBLE FOR SPECIAL, INDIRECT, OR CONSEQUENTIAL DAMAGES, LOSS OF PROFITS, OR COMMERCIAL LOSS IN ANY WAY CONNECTED WITH THE PRODUCTS, WHETHER SUCH CLAIM IS BASED ON CONTRACT, WARRANTY, NEGLIGENCE, OR STRICT LIABILITY.

In no event shall responsibility of OMRON for any act exceed the individual price of the product on which liability is asserted.

IN NO EVENT SHALL OMRON BE RESPONSIBLE FOR WARRANTY, REPAIR, OR OTHER CLAIMS REGARDING THE PRODUCTS UNLESS OMRON'S ANALYSIS CONFIRMS THAT THE PRODUCTS WERE PROPERLY HANDLED, STORED, INSTALLED, AND MAINTAINED AND NOT SUBJECT TO CONTAMINATION, ABUSE, MISUSE, OR INAPPROPRIATE MODIFICATION OR REPAIR.

Application Considerations

SUITABILITY FOR USE

OMRON shall not be responsible for conformity with any standards, codes, or regulations that apply to the combination of products in the customer's application or use of the product.

At the customer's request, OMRON will provide applicable third party certification documents identifying ratings and limitations of use that apply to the products. This information by itself is not sufficient for a complete determination of the suitability of the products in combination with the end product, machine, system, or other application or use.

The following are some examples of applications for which particular attention must be given. This is not intended to be an exhaustive list of all possible uses of the products, nor is it intended to imply that the uses listed may be suitable for the products:

- Outdoor use, uses involving potential chemical contamination or electrical interference, or conditions or uses not described in this catalog.
- Nuclear energy control systems, combustion systems, railroad systems, aviation systems, medical equipment, amusement machines, vehicles, safety equipment, and installations subject to separate industry or government regulations.
- Systems, machines, and equipment that could present a risk to life or property.

Please know and observe all prohibitions of use applicable to the products.

NEVER USE THE PRODUCTS FOR AN APPLICATION INVOLVING SERIOUS RISK TO LIFE OR PROPERTY WITHOUT ENSURING THAT THE SYSTEM AS A WHOLE HAS BEEN DESIGNED TO ADDRESS THE RISKS, AND THAT THE OMRON PRODUCT IS PROPERLY RATED AND INSTALLED FOR THE INTENDED USE WITHIN THE OVERALL EQUIPMENT OR SYSTEM.

Disclaimers

CHANGE IN SPECIFICATIONS

Product specifications and accessories may be changed at any time based on improvements and other reasons.

It is our practice to change model numbers when published ratings or features are changed, or when significant construction changes are made. However, some specifications of the product may be changed without any notice. When in doubt, special model numbers may be assigned to fix or establish key specifications for your application on your request. Please consult with your OMRON representative at any time to confirm actual specifications of purchased product.

DIMENSIONS AND WEIGHTS

Dimensions and weights are nominal and are not to be used for manufacturing purposes, even when tolerances are shown.

ERRORS AND OMISSIONS

The information in this catalog has been carefully checked and is believed to be accurate; however, no responsibility is assumed for clerical, typographical, or proofreading errors, or omissions.

PERFORMANCE DATA

Performance data given in this catalog is provided as a guide for the user in determining suitability and does not constitute a warranty. It may represent the result of OMRON's test conditions, and the users must correlate it to actual application requirements. Actual performance is subject to the OMRON Warranty and Limitations of Liability.

PROGRAMMABLE PRODUCTS

OMRON shall not be responsible for the user's programming of a programmable product, or any consequence thereof.

COPYRIGHT AND COPY PERMISSION

This catalog shall not be copied for sales or promotions without permission.

This catalog is protected by copyright and is intended solely for use in conjunction with the product. Please notify us before copying or reproducing this catalog in any manner, for any other purpose. If copying or transmitting this catalog to another, please copy or transmit it in its entirety.