

Automation & Control **Advantys™ STB IP20** Distributed I/O

Catalog
October

07

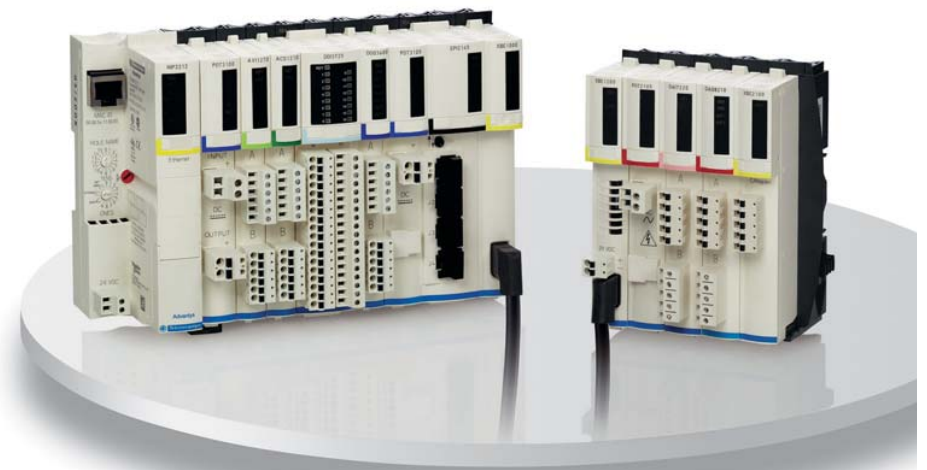

a brand of
Schneider
Electric

 **Telemecanique**

Simply Smart !

us.telemecanique.com



This international site allows you to access all the Telemecanique® brand products in just 2 clicks via comprehensive range data-sheets, with direct links to:

- Complete library: technical documents, catalogs, certificates, FAQs, brochures...
- Selection guides from the e-catalog.
- Product discovery sites and their Flash animations.

You will also find illustrated overviews, news to which you can subscribe, a discussion forum, the list of country contacts...

To live automation solutions every day!



Flexibility

- Interchangeable modular functions, to better meet the requirements for extensions
- Software and accessories common to multiple product families



Ingenuity

- Auto-adapts to its environment, "plug & play"
- Application functions, control, communication and diagnostics embedded in the products
- User-friendly operation either directly on the product or remotely



Simplicity

- Cost effective "optimum" offers that make selection easy for most typical applications
- Products that are easy to understand for users, electricians and automation specialists
- User-friendly intuitive programming



Compactness

- High functionality in a minimum of space
- Freedom in implementation



Openness

- Compliance with field bus, connection, and software standards
- Enabling decentralized or remote surveillance via the web with Transparent Ready® products

Open and Modular System

- Presentation, composition pages 6 to 7
- Description pages 8 to 11
- Functions, characteristics pages 12 and 13

Network Interface Modules

- [Selection guide..... pages 14 and 15](#)
- Presentation, description, characteristics pages 16 to 19
- References pages 20 to 25

Power Distribution Modules

- Presentation, description, characteristics pages 26 to 30
- References pages 31

Digital Input/Output Modules

- [Selection guide..... pages 32 to 37](#)
- Presentation, description, characteristics pages 38 to 45
- References pages 46 and 47
- Wiring pages 48 to 51

Analog Input/Output Modules

- [Selection guide..... pages 52 to 55](#)
- Presentation, description, characteristics pages 56 to 61
- References pages 62 and 63
- Wiring pages 64 to 67

Application-specific Modules

- Parallel Interface for TeSys® Model U Starter-controllers and TeSys® Quickfit applications pages 68 to 73
- Parallel Interface for Tego® Power Applications pages 74 and 75
- Counter module
 - Presentation, description, characteristics pages 76 to 79
 - References, dimensions, wiring pages 80 and 81

Configuration Software

- Presentation page 82
- Functions pages 83 to 86
- References page 87

Dimensions

- Dimensions pages 88 and 89

Combinations

- Combination with Magelis® display units
and operator interface terminals pages 90 and 91
- High-density I/O modules
and Advantys™ Telefast® ABE 7 cabling system pages 92 to 95

Phaseo® Regulated Power Supplies

- Presentation pages 96 to 98
- Characteristics pages 99 and 100
- Combinations of Phaseo power supplies with STB modules page 101
- References, dimensions page 101

Services

- Automation product certifications pages 102 and 103
- Power requirements pages 104 and 105
- Product reference index page 106

Advantys™, Altivar®, Concept™, ConneXium™, Fipio®, Lexium®, Magelis®, Modbus®, ModbusPlus™, Modicon®, Momentum™, Phaseo®, PL7™, Premium™, Preventa™, ProWORX™, Quantum™, Tego®, Telefast®, Telemecanique®, TeSys®, Transparent Ready®, TSX Micro™, Twido®, and Unity™ are trademarks or registered trademarks of Schneider Electric.

Other trademarks used herein are the property of their respective owners.

Advantys™ STB Distributed I/O Solution

Open and Modular System



Presentation

To meet the needs of machine manufacturers and users, automation architectures have been decentralized while delivering performance close to that of centralized systems.

Installed as close to the machine as possible, these island architectures reduce the time and cost of wiring for sensors and actuators, while increasing system availability.

The Advantys STB distributed I/O system is an open, modular input/output system and makes it possible to design automation islands managed by a master controller via a bus or communication network.

This distributed I/O system can be used to connect:

- Motor-starters.
- Variable speed drives.
- Magelis® operator interface terminals.
- Qualified third-party products via the CANopen bus: Festo®, Parker® valves, IP 67 FTB distributed I/O, Altivar® variable speed drives, encoders etc.

Advantys software supports the user from the design phase to the start-up and maintenance of the system. This unique software covers the Advantys STB, OTB, FTB and FTM ranges.

The island components are in the form of electronic modules mounted on DIN rails to create one or more segments in which the power supplies (logic, sensors and actuators) are distributed automatically.

The Advantys STB I/O family can be divided into 2 groups of modules:

- **Basic modules:** A full set of economical network modules and interfaces, with simplified operating modes.
- **Standard modules:** An extended range of input/output modules, with additional functions: configurable parameters, extended operating modes.

The basic and standard ranges comprise:

- NIM modules: network interfaces.
- PDM power distribution modules (≡ 24 V and ~ 115/220 V).
- Input/output modules:
 - Digital I/O (≡ 24 V and ~ 115/220 V).
 - Analog I/O, 10, 12 and 16 bit-resolution.
 - Relay outputs (≡ 24 V coil and ≡ 24 V or ~ 115/230 V contact).
- Application-specific I/O module: Counter module.
- Dedicated modules:
 - for TeSys® Quickfit, TeSys® Model U starter-controllers application.
 - for Tego® Power applications.
- EOS end of segment and BOS beginning of segment modules.
- External equipment support module on CANopen extension.

Basic and standard modules can be combined on the same island. Combining them in this way allows a wide range of functions as shown in the table on page 12.

The sensors and actuators are connected to the I/O modules via removable screw- or spring-type connectors.

Advantys STB modules are hot-swappable, provided the network interface modules are of standard type.

The Advantys STB distributed I/O system features a protection rating of IP 20. For installations in production workshops, the Advantys STB distributed I/O system must be incorporated in protective housings with at least an IP 54 rating (in compliance with IEC 60950 or NEMA 250 standards). See page 103.

Color code	Type of module
Yellow	NIM network interface EOS/BOS island extension CANopen extension
Yellow	
Light Blue	≡ 24 V digital inputs
Light Blue	
Dark Blue	≡ 24 V power supply ≡ 24 V digital outputs
Dark Blue	
Light Pink	~ 115 V or ~ 230 V digital power inputs
Light Pink	
Dark Pink	~ 115/230 V power supply ~ 115/230 V digital power outputs
Dark Pink	
Black	Relay digital outputs TeSys® Model U starter-controllers, TeSys® Quickfit and Tego® Power interface, counter module
Black	
Light Green	Analog inputs
Light Green	
Dark Green	Analog outputs
Dark Green	

Composition of an Advantys STB island

An Advantys STB island is made up of one or more segments comprising PDMs (*Power Distribution Modules*) and input/output modules.

An Advantys STB island starts with a network interface module and ends with a bus terminator supplied with this module.

An island can be made up of a single segment or a primary segment and up to 6 extension segments, chained by EOS (*End Of Segment*) and BOS (*Beginning Of Segment*) extension modules.

On each segment:

- The PDMs (Power Distribution Modules) must be placed immediately to the right of the network interface modules or extension modules.
- The I/O modules are placed to the right of the PDM module supplying them with power.
- Every module, whether PDM or I/O, is held in a fixing base on the DIN rail. (1) Three module and base widths are possible. On the DIN rail, the overall width needed for a segment is the sum of widths of the network interface module, the bases and any bus termination.

The bases ensure the continuity of the internal bus, the auto-addressing of the modules and the separated and isolated distribution of the internal power supplies, actuators and sensors.

The advantages of this arrangement are:

■ Unplugging of modules:

- When switched off, all modules can be unplugged very quickly.
- When switched on (*hot swap*), I/O modules can be unplugged provided the network interface module is of standard type.

■ Output power supply independent of inputs:

For example, if an output power supply is cut by a Preventa™ safety module, the inputs are still managed.

■ Immunity of inputs:

For example, the closing of power contactors (controlled by outputs) does not disturb analog input measurements.

The NIM (*Network Interface Module*)

This module manages communications on the island bus. It acts as a gateway for exchanges with the fieldbus or network master. 11 NIM models are offered for: Ethernet TCP/IP (standard only), CANopen, Modbus Plus™ (standard only), Fipio® (standard only), INTERBUS®, Profibus DP and DeviceNet networks.

(1) Each module (apart from the NIM Network Interface Module) requires a base and one or more specific connectors.

Advantys™ STB Distributed I/O Solution

Open and Modular System

Description of Advantys STB basic

Advantys STB basic: single segment

With a basic network interface module it is possible to realize an island with only one segment (a “single” segment) comprising up to 12 input/output modules (excluding PDM power distribution modules, network interface module and bus termination).

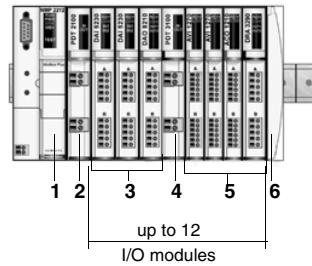

Single segment basic Advantys STB

In the example above, the single segment comprises:

- 1 STB N●● 1010: an NIM (*Network Interface Module*). It is placed at the beginning of the primary segment. Each island must have one NIM module only.
- 2 STB PDT 2105: a PDM (*Power Distribution Module*). It is installed immediately to the right of the NIM and supplies $\sim 115/230$ V to the input/output modules requiring AC power.
- 3 STB DA●: digital I/O modules with AC power.
- 4 STB PDT 3105: PDM power distribution module. It is installed after all the $\sim 115/230$ V I/O modules. It provides ~ 24 V to the I/O modules requiring DC power.
- 5 STB AV● and STB AC●: analog I/O modules requiring DC power. They are installed after the PDM.
- 6 STB XMP 1100: bus termination, supplied with the NIM network interface module.

Internal power supply: The NIM network interface module STB N●● supplies a ~ 5 V logic voltage (1.2 A) from an external ~ 24 V power supply.

Advantys™ STB Distributed I/O Solution

Open and Modular System

Standard Advantys STB configurations

Standard Advantys STB: single segment

With a standard NIM network interface module it is possible to realize an island with only one segment (a "single" segment) comprising up to 32 input/output modules (excluding PDM power distribution modules, network interface module, bus termination and auxiliary power supplies).

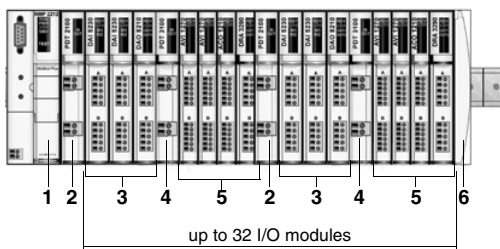

Single segment standard Advantys STB

In the example above, the primary segment comprises:

- 1 STB N●● 2212: a standard type NIM (*Network Interface Module*). It is placed at the beginning of the primary segment. Each island must have one NIM module only.
- 2 STB PDT 210●: a PDM (*Power Distribution Module*). It is installed immediately to the right of the NIM and supplies $\sim 115/230$ V to the input/output modules requiring AC power.
- 3 STB DA●: digital I/O modules with AC power.
- 4 STB PDT 310●: PDM power distribution module. It is installed after all the $\sim 115/230$ V I/O modules. It provides ~ 24 V to the I/O modules requiring DC power.
- 5 STB AV●, STB AC●, STB DD●: digital or analog I/O modules requiring DC power. They are installed after the PDM STB PDT 310● module.
- 6 STB XMP 1100: bus termination (1).

Auxiliary internal power supply: The auxiliary power supply module STB CPS 2111 supplies a ~ 5 V logic voltage (1.2 A) from an external ~ 24 V power supply.

Advantys™ STB Distributed I/O Solution

Open and Modular System

Standard Advantys STB: primary segment and extension segments

The island bus can support the primary segment with up to 6 extension segments (7 segments in all).

A standard NIM network interface module supports up to 32 I/O modules (excluding PDM power distribution modules, network interface module, bus termination, auxiliary power supplies and EOS/BOS bus extension modules).

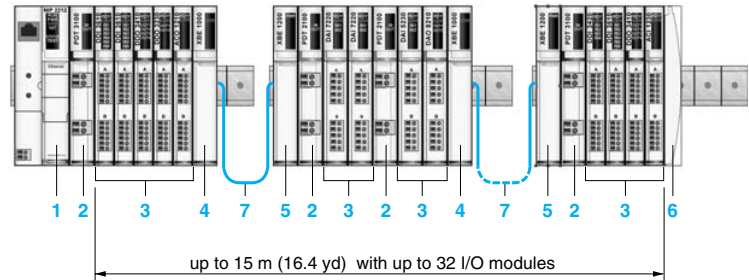

Standard Advantys STB with 3 segments

The segments of the Advantys STB configuration shown above are composed of:

- 1 STB N●● 2212: NIM network interface module. It is placed at the beginning of the primary segment. Each island must have one NIM module only.
- 2 STB PDT ●100: PDM power distribution module (~ 24 V or $\sim 115/230$ V). It is installed immediately to the right of the NIM and provides ~ 24 V or $\sim 115/230$ V depending on the type of I/O modules located on the right.
- 3 STB AV●, STB AC●, STB DD●, STB DA● and STB DR●: I/O modules requiring DC power or digital modules requiring AC power. They are located immediately to the right of the PDM.
- 4 STB XBE 1000: EOS bus extension module. It is always installed in the farthest right slot in the primary or extension segment, and is used to extend the island bus to another segment.
- 5 STB XBE 1200: BOS bus extension module. It is installed at the beginning of each extension segment.
- 6 STB XMP 1100: island bus termination (1).
- 7 STB XCA 100●: island bus extension cables.

Internal power supply of secondary segments: The BOS bus extension module STB XBE 1200 supplies a ~ 5 V logic voltage (1.2 A) from an external ~ 24 V power supply.

(1) Supplied with the corresponding NIM network interface module.

Advantys™ STB Distributed I/O Solution

Open and Modular System

Standard Advantys STB: CANopen extension module - Device Integration

The CANopen extension module STB XBE 2100 can be used to connect, at the end of the segment, external CANopen devices such as:

- IP67 Advantys FTB I/O, in plastic or metal casing.
- Altivar® 31/61▲/71▲ variable speed drives.
- Festo® CPV-CO2 electropneumatic valves.
- Parker® P2M2HBVC11600 electropneumatic valves.
- Balluff® Micropulse BTL5▲ linear encoders (1).

The number of CANopen external devices depends on the standard network interface module of the island:

CANopen, DeviceNet external devices (up to 7).

Ethernet TCP/IP Modbus®, Modbus Plus™, INTERBUS®, Profibus DP, Fipio® external devices (up to 12).

The baud rate of the internal bus is set to 500 Kbps with the configuration software Advantys STB SPU 1●●●. This speed applies to all the Advantys STB modules and to the external devices.

Standard Advantys STB: Application-specific modules, preferred module and devices

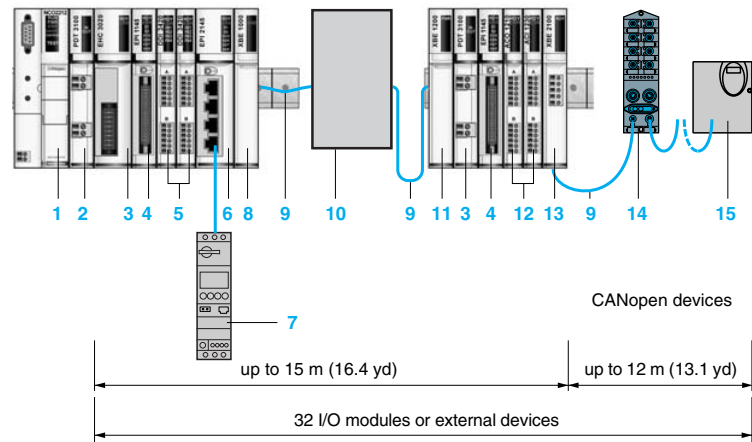

Standard Advantys STB with CANopen devices

A standard network interface module supports up to 32 I/O modules and external CANopen devices (excluding PDM power distribution modules, network interface module, bus termination, auxiliary power supplies, EOS/BOS bus extension modules and CANopen STB XBE 2100 extension module).

The island bus can support:

- Preferred modules (available later). This type of preferred module is installed between two segments.
- Standard CANopen devices.

The island bus in the above example comprises:

- 1 STB N●● 2212: an NIM (*Network Interface Module*).
- 2 STB PDT 3100: --- 24 V PDM (*Power Distribution Module*).
- 3 STB EHC 3020: 1-channel counter module.
- 4 STB EPI 1145: parallel interface module.
- 5 STB DDI 3420: digital input modules.
- 6 STB EPI 2145: module for TeSys® Model U starter-controllers.
- 7 TeSys® Model U or TeSys® Quickfit starter-controller.
- 8 STB XBE 1000: EOS bus extension module It is always installed in the farthest right slot in the primary or extension segment, and is used to extend the island bus to another segment.
- 9 STB XCA 100●: island bus extension cables.
- 10 Preferred module.
- 11 STB XBE 1200: BOS bus extension module placed at the beginning of the segment.
- 12 STB AC●: analog I/O modules.
- 13 STB XBE 2100: CANopen extension module (up to 12 devices per island).
- 14 IP67 I/O Advantys FTB.
- 15 Altivar® variable speed drive.

▲ Pending or in process at time of printing.

(1) To obtain the latest list of qualified equipment on the Advantys STB island extension, please consult your Regional Sales Office or visit www.us.telemecanique.com.
To validate a new product, please consult your Regional Sales Office.

Basic/standard Advantys STB functions

The table below sets out the main features of the basic and standard Advantys STB ranges:

Advantys STB	I/O modules		NIM network interface modules		PDM power distribution modules		see page
	Basic	Standard	Basic	Standard	Basic	Standard	
Max. no. of I/O modules			12	32			8 to 11
Field wiring connectors							–
Keying pin							39
Cold swapping							12
Hot swapping (1) (3)							12
Separate power supply to sensors and actuators	(2)	(2)					26
Integrated electronic output protection					(3)		–
Electronic protection of power supply provided by Advantys STB for sensors							–
Power supply protected by removable integrated fuse							–
Status LEDs							–
Compatible with all types of network interface module							–
CANopen extension - Device integration							11
Local HMI compatibility (Magelis)							90
Default configuration							82
Design, installation and maintenance supported by Advantys software (4)							83
Configurable I/O parameters (4)							83
Built-in reflex functions							86
Removable memory card (4) (5)							16
Advanced diagnostics (4)							84
Internal software update (firmware)							17

Available function
 Non-available function
 Not applicable

- (1) See below.
- (2) Requires standard PDM power distribution modules.
- (3) Fuse protection only.
- (4) Requires standard NIM network interface module.
- (5) To support internal island parameters, simplifies replacement of faulty devices (FDR) and copying of island parameters.

Hot swapping

When a module of the Advantys STB island is unplugged under power, the behavior of the other modules depends:

- on the type (basic/standard) of the NIM network interface module.
- on the parameter settings of standard type I/O modules:
 - mandatory/optional module.
 - configured fallback type, per channel.

Unplugging of module	Type of network interface module	
	Basic NIM	Standard NIM (1)
Basic input	All outputs fall back to 0	Other outputs remain operational
Standard input optional	All outputs fall back to 0	Other outputs remain operational (1)
Standard input mandatory	All outputs fall back to 0	Fallback of other outputs depending on parameter setting (1)(2)
Basic output	All outputs fall back to 0	Other outputs remain operational
Standard output optional	All outputs fall back to 0	Other outputs remain operational (1)
Standard output mandatory	All outputs fall back to 0	Fallback of other outputs depending on parameter setting (1)(2)
PDM power distribution module	Illegal	Illegal
NIM network interface module	Illegal	Illegal

- (1) Fallback level regulated by the software Advantys STB SPU 1●●● on standard I/O modules with a standard NIM.
Software STB SPU 1●●● is not connected on NIM basic modules.
- (2) The fallback state is adjustable on standard output modules:
 - Fallback to 0 for digital modules.
 - Fallback to 1 for digital modules.
 - Fallback to any value on analog outputs.
 - Hold last value on digital and analog outputs.

Operating environment

Advantys STB devices satisfy the following regulatory agency certifications:

- UL
- CSA
- CE
- FM Class 1, Div. 2

They are designed for use in industrial environments of pollution class 2, in applications of over voltage category II (as defined in publication IEC 60664-1) and at altitudes of up to 2000 m (2187.22 yd), without reduction in load.

General environmental characteristics

Parameter		Specification
Protection		IP 20, class 1. ref. EN61131-2
Operating temperature	°C	0...60 (32...140 °F) without derating
Storage temperature	°C	-40...+85 (-40...+185 °F) without derating
Maximum humidity		95% relative humidity at 60°C (140°F) without condensation
Sinusoidal vibration	Hz	10...58 at ± 0.35 mm (0.0137") 58...150 at 5 g on a 15 mm (0.59") DIN rail 58...150 at 3 g on a 7.5 mm (0.29") DIN rail
Shock	g	30 peak for 11 ms, semi-sinusoidal wave for 3 shocks per axis. Ref. IEC 88, reference 2-27

Advantys™ STB Distributed I/O Solution

Network Interface Modules

Applications	Data exchange between master PLC and Advantys STB I/O modules	
Bus or network type	Ethernet TCP/IP Network	CANopen bus



Bus or network nature	Industrial LAN	CAN field bus
Structure	Physical interface	10 BASE-T
	Data rate	10 Mbit/s
Medium	Shielded dual twisted pair via Ethernet ConneXium™ cabling system	Shielded dual twisted pair
Configuration	Number of devices (1)	Up to 256 per segment, unlimited with switches
	Maximum length	100 m (109.3 yd) according to 802.3 standard 1000 m (1093.6 yd) with ConneXium™ cabling system > 3000 m (3280.8 yd) with fiber optic connection
NIM (Network Interface Module) features	Number of I/O modules per Advantys STB island (1)	Standard NIM: up to 32 modules on 1 primary segment and up to 6 extension segments
	Power supply	--- 24 V not isolated (19.2...30 V)
	Logic power supply	Provides --- 5 V logic power to all the I/O modules of an island (1200 mA)
	CANopen devices supported	Up to 12 devices (2)
Services used	- Embedded Web (configuration, diagnostics, and access to variables) - TCP/IP Modbus - SNMP agent - DHCP client service	- Process Data Object (PDO) - Service Data Object (SDO) - Network management (NMT)
	Type of NIM module	STB NIP 2212
	Standard	STB NCO 2212
	Basic (3)	STB NCO 1010

Pages 20

(1) One Advantys STB island corresponds to 1 device on the bus or the network.
 (2) Depending on the nature of the CANopen devices, this maximum number may be limited to 7.
 (3) Does not support: the CANopen bus extension module, hot swapping, Advantys software.

Data exchange between master PLC and Advantys STB I/O modules

Modbus Plus™ network	Fipio® bus	INTERBus® bus	Profibus DP bus	DeviceNet network
----------------------	------------	---------------	-----------------	-------------------



Industrial LAN compliant with the Modbus Plus standard	Open industrial field bus compliant with the FIP standard	INTERBUS industrial field bus (Generation 4)	Industrial field bus Profibus DPV.0	Network compliant with v.2.0 of the Open DeviceNet Vendor Assoc. (ODVA)
Modbus Plus standard	FIP standard	Isolated RS 485	RS 485	–
1 Mbit/s	1 Mbit/s	500 Kbit/s	9.6 Kbit/s...12 Mbit/s	125, 250 or 500 Kbit/s
Twisted pair	Shielded twisted pair cable	Shielded twisted pair cable	Shielded twisted pair cable	Twisted pair
32 per segment 64 for all segments	32 per segment Up to 128 for all segments	Up to 512 slaves with up to 254 bus terminal blocks	125 slaves	64 slaves
450 m (492.1 yd) per segment 1800 m (1968.4 yd) with 3 repeaters	1000 m (1093.6 yd) per segment	400 m (437.4 yd) per bus segment between stations 12.8 km for the bus between stations 50 m (54.6 yd) for the installation bus	1200 m (1312.3 yd) (9.6 Kbit/s), 4800 m (5249.3 yd) with 3 repeaters, 200 m (218.7 yd) (12 Mbit/s), 800 m (874.8 yd) with 3 repeaters	1200 m (1312.3 yd)
Standard NIM: up to 32 modules on 1 primary segment and up to 6 extension segments		Standard NIM: up to 32 modules on 1 primary segment and up to 6 extension segments Basic NIM: Up to 12 modules on 1 primary segment		
Up to 12 devices (2)				
- Global data - Peer-to-peer - Peer Cop	- Periodic I/O exchanges - Point-to-Point message - Use of standard profiles FRD/FSD/FED	- Implicit process data exchange ((Data process) - Logical addressing - Diagnostics	- Slave configuration - Configuration control - Read/write Slave I/O data	- DeviceNet Object (Class ID3) - Connection Object (Class ID5) - Island Bus Object (Class ID101)
STB NMP 2212	STB NFP 2212	STB NIB 2212	STB NDP 2212	STB NDN 2212
		STB NIB 1010	STB NDP 1010	STB NDN 1010

Advantys™ STB Distributed I/O Solution

Network Interface Modules

Presentation

The STB N●● 2212 and STB N●● 1010 NIM (*Network Interface Module*), located at the beginning of each island, are gateways for exchanging data between the network or bus master PLC and the Advantys STB automation island.

The standard modules STB N●● 2212 also allow configuration and addressing of the external devices of the installation. These settings are stored in the module's internal RAM or Flash memory. They can be saved on the STB XMP 4440 32 KB removable memory card - apart from the address of the network connection point - in order to copy the configuration of one island to another.

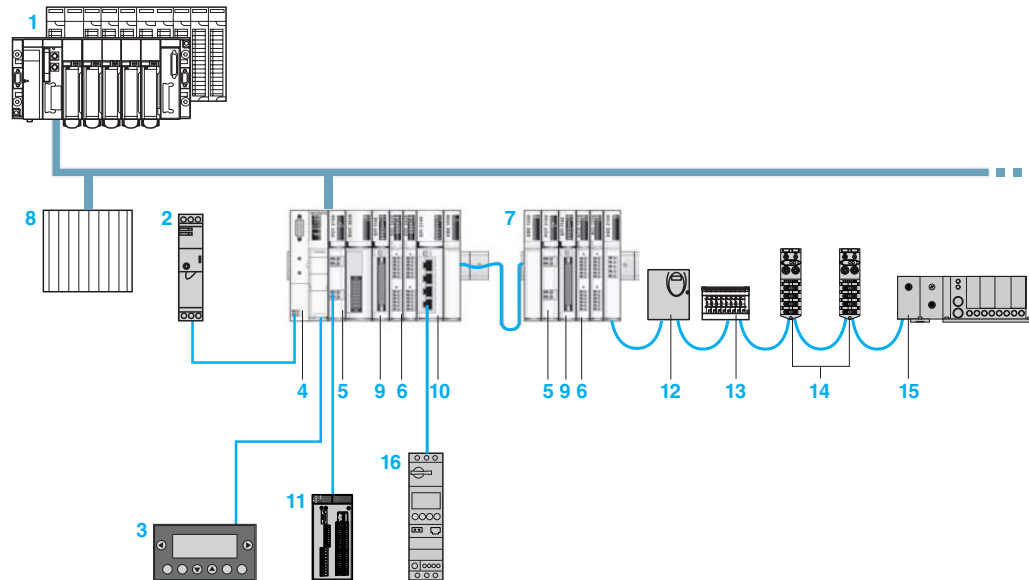

- 1 Fieldbus or network master.
- 2 External --- 24 V power supply.
- 3 HMI terminal with Modbus® connection, Magelis® type XBT, XBT G, XBT GT displays, see connection cables on page 92.
- 4 NIM (*Network Interface Module*).
- 5 PDM (*Power Distribution Module*).
- 6 I/O modules.
- 7 Second STB segment.
- 8 Other automation system.
- 9 Parallel interface module for Tego® application.
- 10 Parallel interface module for TeSys® Model U and TeSys® Quickfit starter-controller.
- 11 Configurable safety controller Preventa™ type XPS MC connected to the power supply at the outputs of the power distribution module STB PDT ●100.
- 12 Altivar® variable speed drive.
- 13 Festo® solenoid valves.
- 14 IP67 I/O Advantys FTB.
- 15 Parker® solenoid valves.
- 16 TeSys® Model U starter-controller.

Advantys™ STB Distributed I/O Solution

Network Interface Modules

The range of NIM network interface modules comprises 4 basic NIM modules and 7 standard NIM modules.

Each module is dedicated to a specific network or bus:

Network or bus	Basic network interface module	Standard network interface module
Ethernet network	–	STBNIP2212
CANopen bus	STBNCO1010	STBNCO2212
Modbus Plus™ network	–	STBNMP2212
Fipio® bus	–	STBNFP2212
INTERBUS® bus	STBNIB1010	STBNIB2212
Profibus DP bus	STBNDP1010	STBNDP2212
DeviceNet network	STBNDN1010	STBNDN2212

Power supply for network interface modules

Network interface modules are powered by an external ± 24 V source.

They convert this voltage to ± 5 V to supply logic power to the I/O modules of the primary Advantys STB segment.

These integrated 5 V logic power supplies provide a maximum current of 1.2 A.

This current of 1.2 A can be increased through the addition, in each segment, of an auxiliary power supply STB CPS 2111 which also provides a maximum current of 1.2 A (see page 30).

Logic power for the I/O modules of the extension segments is provided by the BOS bus extension module STB XBE 1200 placed at the beginning of these segments. See page 30.

Advantys™ STB Distributed I/O Solution

Network Interface Modules

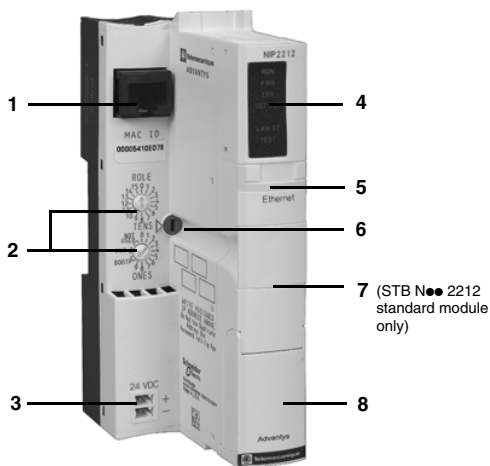

Interface modules with network/bus address selectors.

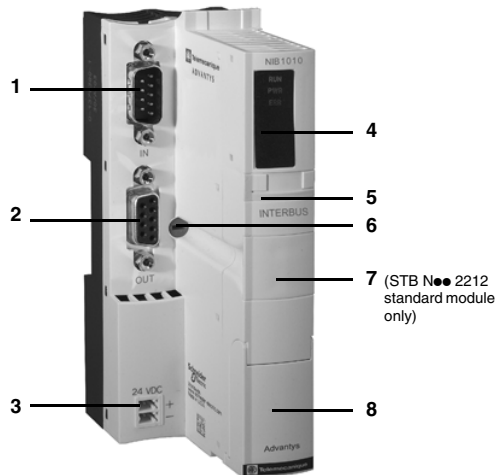

INTERBUS STB NIB 2212/1010 interface modules

Description

Network interface modules STB N●● 2212/1010

The front panel of the STB N●● 2212/1010 network interface module has the following features:

- 1 A connector to connect the island to the fieldbus. See photos of different types of connectors on pages 14 and 15 and characteristics on page 19.
- 2 - All NIM modules except INTERBUS NETWORK INTERFACE: Two rotary node addressing selectors on the bus or the network.
- INTERBUS STB NIB 2212/1010 NETWORK INTERFACE modules: A 9-pin SUB-D female connector used to connect the output bus cable.
- 3 An external 24 V power connector for the removable screw-type (STB XTS 1120) or spring-type (STB XTS 2120) connector.
- 4 A display block with LEDs for the various island states on the bus: power, communication, send/receive data, errors, etc.

Indication	Basic NIM modules	Standard NIM modules
Island state: auto-configuration, operational, error etc.(1)	Green RUN LED	Green RUN LED
Power supply: NIM switched on, internal 5V operational	Green PWR LED	Green PWR LED
Module error (2)	Red ERR LED	Red ERR LED
1 to 3 LED status indicators	Depending on bus/network	Depending on bus/network
Test mode(3)	–	Yellow Test LED

- 5 A color-coded module identification stripe: yellow.
- 6 A screw for releasing the STB N●● 2212/1010 module from the DIN rail.
The NIM can be withdrawn from the island even if the product is assembled: simply withdraw the PDM then turn this screw a quarter turn.
- 7 A slot for a removable SIM card STB XMP 4440 (only on standard NIM modules STB N●● 2212).
- 8 - Standard NIM module: door giving access to the port used to connect an island setup and configuration PC or an HMI terminal (read/write data), and the Reset button (4). Can also be used to update the firmware for the network interface module (5).
- Basic NIM module: door giving access to the port used to connect a PC (for updating the firmware for the network interface module only) and the Reset button (4).

The network interface modules are supplied with:

- a mini CD-ROM containing documentation in English, label templates and one exchange file per network type.
 - STB XMP 1100 bus termination
- They are mounted directly on the DIN rail.

The CD-ROM STB SUS 8800 contains specific documentation for each of the 11 network interface modules in 5 languages. These documents can also be downloaded from www.us.telemecanique.com.

(1) RUN is on permanently if the module is operational and flashes in different ways in the other states.

If RUN flashes on start-up, the NIM module is in the auto-configuration phase.

If RUN flashes for a long time, there is a fault on the island. For information about the signaling of NIM and island states, consult the "NETWORK INTERFACE module applications guide" for the network concerned included on the CD-ROM STB SUS 8800 or available from our website www.us.telemecanique.com.

(2) ERR is off when the island is OK. Otherwise, ERR flashes or is lit.

(3) Test off: island OK. Test flashing: backup of parameters to internal memory or SIM card in progress. Test on: island in test mode.

(4) Pressing the Reset button for 4 seconds restores the island to the factory settings or settings equivalent to content of SIM card.

(5) Firmware update of NIM modules available at www.us.telemecanique.com.

Advantys™ STB Distributed I/O Solution

Network Interface Modules

Characteristics							
Type of network interface module		STB	NIP 2212	NCO 2212	NCO 1010	NMP 2212	NFP 2212
Range			Standard	Standard	Basic	Standard	Standard
Network or bus			Ethernet	CANopen		Modbus Plus	Fipio
Compliance with bus or network standards			IEEE 802.3	CIA DS-301		modbus.org	EN 50170, Vol 3, Parts 1-3, 2-3, 3-3, 5-3, 6-3 and 7-3
Power supply		$\equiv V$	24 not isolated (1)				
Input current		mA	700	700	400	700	
Voltage limits		$\equiv V$	19.2...30				
Output voltage to the island logic bus		\equiv	5.25 V \pm 0.21%				
Output current rating		A	1.2				
Isolation			None				
Immunity to electromagnetic interference (EMC)			Yes, according to IEC 61131-2				
Connector type	To bus or network		RJ45 female	9-pin SUB-D male		9-pin SUB-D female	9-pin SUB-D male
	RS 232 port (configuration, dialog with XBT and firmware update)		HE 13, 8-pin female	HE 13, 8-pin female	(2)	HE 13, 8-pin female	
Max. number of addressable I/O modules		Per island	32	32	12	32	
Number of segments supported	Primary		1				
	Extension		up to 6	up to 6	–	up to 6	

Type of STB network interface module								
Type of STB network interface module		STB	NIB 2212	NIB 1010	NDP 2212	NDP 1010	NDN 2212	NDN 1010
Range			Standard	Basic	Standard	Basic	Standard	Basic
Network or bus			INTERBus		Profibus DP		DeviceNet	
Compliance with bus or network standards			INTERBus Club		DIN 19245, Parts 1 and 3		Open DeviceNet Vendors Assoc.	
Power supply		$\equiv V$	24 not isolated (1)					
Input current		mA	700	400	700	400	700	400
Voltage limits		$\equiv V$	19.2...30					
Output voltage to the island logic bus		\equiv	5.25 V \pm 0.21%					
Output current rating		A	1.2					
Output impedance		mΩ	< 50 to 100 kHz	\leq 50	< 50 to 100 kHz	\leq 50	< 50 to 100 kHz	\leq 50
Isolation			None					
Immunity to electromagnetic interference (EMC)			Yes, according to IEC 61131-2					
Connector type	To bus or network		Input: 9-pin SUB-D male Output: 9-pin SUB-D female		9-pin SUB-D female		5-pin male connector	
	RS 232 port (configuration, dialog with XBT and firmware update)		HE 13, 8-pin female	(2)	HE 13, 8-pin female	(2)	HE 13, 8-pin female	(2)
Max. number of addressable I/O modules		Per island	32	12	32	12	32	12
Number of segments supported	Primary		1					
	Extension		up to 6	–	up to 6	–	up to 6	–

(1) Use a \equiv 24 V SELV (Safety Extra Low Voltage) external power supply.
 (2) Connection for updating firmware only.

Advantys™ STB Distributed I/O Solution

Network Interface Modules



STB NIP 2212

STB NCO 2212/1010



STB NMP 2212

STB NFP 2212



STB NIB 2212/1010

STB NDN 2212/1010

Network interface modules (1)

Network or bus	Range	Power supply (2)	Catalog number	Weight kg
Ethernet network	Standard	≡ 24 V	STBNIP2212	0.130
CANopen bus	Standard	≡ 24 V	STBNCO2212	0.135
	Basic	≡ 24 V	STBNCO1010	0.135
Modbus Plus™ network	Standard	≡ 24 V	STBNMP2212	0.145
Fipio® bus	Standard	≡ 24 V	STBNFP2212	0.145
INTERBUS® bus	Standard	≡ 24 V	STBNIB2212	0.155
	Basic	≡ 24 V	STBNIB1010	0.155
Profibus DP bus	Standard	≡ 24 V	STBNDP2212	0.140
	Basic	≡ 24 V	STBNDP1010	0.140
DeviceNet network	Standard	≡ 24 V	STBNDN2212	0.140
	Basic	≡ 24 V	STBNDN1010	0.140

Separate parts

Designation	Use	Sold in lots of	Catalog number	Weight kg
Removable connectors for ≡ 24 V power supply 2 contacts	Screw-type	10	STBXTS1120	0.003
	Spring-type	10	STBXTS2120	0.003
DeviceNet removable connectors 5 contacts	Screw-type	1	STBXTS1111	–
	Spring-type	1	STBXTS2111	–

Replacement and optional parts

Designation	Use	Catalog number	Weight kg
32 KB removable SIM card (2)	For backup of island configuration.	STBXMP4440	–
External ≡ 24 V power supply (SELV)	–	See page 100	–
Configuration software (2)	–	See page 86	–
Magelis XBT terminal connection cable (2)	–	See page 90	–
RS 232C shielded twisted pair cable HE 13 8 contacts/ SUB-D 9 contacts length 2 m (2.18 yd) (2) (3)	Configuration PC	STBXCA4002	0.210
Sub-D USB cable	Configuration PC with USB port Requires STB XCA 4002 (3)	SR2CBL06	0.185
User documentation	Multilingual (English, French, German, Spanish and Italian) on CD-Rom	STBSUS8800	–
Bus terminator	Also supplied with NIM network interface module	STBXMP1100	–

(1) All network interface modules are supplied with English documentation on mini-CD-Rom and bus terminators (STB XMP 1100).

(2) Standard modules only.

(3) Supplied with configuration software STB SPU 1●●●, see page 86.



TSX CAN TDM4



490 NTW 000 ●●

Connection accessories

CANopen bus

Designation	Fitted at ends	Length	Catalog number	Weight kg
CANopen IP 20 junction box	4 SUB-D ports. Screw terminals for connection of main cables Line termination		TSXCANTDM4	0.196
Pre assembled CANopen cables 1 SUB-D connector, 9-way, female at each end.	Standard, C€ marking: low smoke emission. Halogen-free. No flame propagation (IEC 60332-1)	0.3 m (0.328 yd)	TSXCANCADD03	0.091
		1 m (1.09 yd)	TSXCANCADD1	0.143
		3 m (3.28 yd)	TSXCANCADD3	0.295
		5 m (5.46 yd)	TSXCANCADD5	0.440
		0.3 m (0.328 yd)	TSXCANCBDD03	0.086
	Standard, UL certification, C€ marking: No flame propagation (IEC 60332-2)	1 m (1.09 yd)	TSXCANCBDD1	0.131
		3 m (3.28 yd)	TSXCANCBDD3	0.268
		5 m (5.46 yd)	TSXCANCBDD5	0.400

Ethernet network

Designation	Fitted at ends	Length	Catalog number	Weight kg
Straight shielded twisted pair cable for connecting hubs and switches	2 RJ45 connectors to connect data terminal equipment (DTE)	2 m (2.18 yd)	490NTW00002 (1)	–
		5 m (5.46 yd)	490NTW00005 (1)	–
		12 m (13.1 yd)	490NTW00012 (1)	–
		40 m (43.7 yd)	490NTW00040 (1)	–
		80 m (87.4 yd)	490NTW00080 (1)	–

(1) Cable compliant with EIA/TIA-568 standard and IEC 1180/EN 50 173 in class D. For UL and CSA 22.1 certified cables, add letter **U** to end of the reference.



AS MBKT 085

Connection accessories (continued)

Modbus Plus™ network

Designation	Use	Catalog number	Weight kg
9-pin SUB-D male connector	Connection of the Modbus Plus connector	ASMBKT085	–
Modbus Plus junction box	IP 20 device for T connections	990NAD23000	0.230
	IP 65 unit for T connections, supports 1 RJ45 connector on front panel	990NAD23010	0.650
	IP 20 T connector with 2 RJ45 connectors for Modbus Plus cable and one 9 pin SUB-D connector for auxiliary devices	170XTS02000	0.260

Designation	Use	Length	Catalog number	Weight kg	
Modbus Plus drop cables	IP 20 170 XTS 020 00 T connector	IP 20 170 XTS 020 00 T connector	0.25 m (0.27 yd)	170MCI02010	–
			1 m (1.09 yd)	170MCI02036	–
			3 m (3.28 yd)	170MCI02120	–
			10 m (10.9 yd)	170MCI02080	–
	STB NMP 2212 990 NAD 230 00 network interface module	junction box	2.4 m (2.62 yd)	990NAD21110	0.530
			6 m (6.56 yd)	990NAD21130	0.530

Fipio® bus

Designation	Use	Characteristics	Catalog number	Weight kg
Female connectors (9-pin SUB-D)	On STB NFP 2212 network interface module	Black polycarbonate IP 20	TSXFPACC12	0.040
		Zamak® alloy(1)	TSXFPACC2	0.080
Bus connection unit	Junction for main cable	Black polycarbonate IP 20	TSXFPACC14	0.120
		Zamak IP 65 (1)	TSXFPACC4	0.660

Designation	Use	Length	Catalog number	Weight kg
Drop cables	8 mm (0.31"), 2 shielded twisted pairs 150 Ω For standard environments	100 m (109.3 yd)	TSXFPCC100	5.680
		200 m (218.7 yd)	TSXFPCC200	10.920
		500 m (546.8 yd)	TSXFPCC500	30.000
Daisy chaining cables	8 mm (0.31"), 2 shielded twisted pairs 150 Ω For standard environments	100 m (109.3 yd)	TSXFPCA100	5.680
		200 m (218.7 yd)	TSXFPCA200	10.920
		500 m (546.8 yd)	TSXFPCA500	30.000

(1) Not suitable for applications subject to vibrations ≥ 1 g or strong shocks.



TSX FP ACC 12



TSX FP ACC 14



TSX FP ACC 4

Connection accessories (continued)

INTERBUS® Bus

Designation	Use	Length	Catalog number	Weight kg
Installation bus cables	Pre assembled cables for connecting 2 network interface modules	0.110 m (0.12 yd)	170MCI00700	–
		1 m (1.09 yd)	170MCI10000	–
Junction interface	To connect inter-station bus to installation bus	–	170BNO67100	–
Inter-station bus cables	–	100 m (109.3 yd)	TSXIBSCA100	–
		400 m (437.4 yd)	TSXIBSCA400	–

Profibus DP bus

Designation	Use	Length	Catalog number	Weight kg
Connectors for STB NDP 2212 network interface module	Bus terminator	–	490NAD91103	–
	Intermediate connection	–	490NAD91104	–
	Intermediate connection with terminal port	–	490NAD91105	–
Profibus DP connection cables	–	100 m (109.3 yd)	TSXPBSCA100	–
		400 m (437.4 yd)	TSXPBSCA400	–

DeviceNet network

Designation	Use	Type	Catalog number	Weight kg
Female 5-pin connectors	For STB NDN 2212 network interface module	Screw-type	STBXTS1111	–
		Spring-type	STBXTS2111	–



STB XBE 1000



STB XBE 1200



STB XBE 2100



STB CPS 2111



STB XBA 2000

Internal bus extensions

Designation	Use with standard STB	Catalog number	Weight kg
EOS internal bus extension module	Installed at end of segment (except for the last segment on the island)	STBXBE1000	–
BOS internal bus extension module	Installed at the beginning of each extension segment	STBXBE1200	–
Bus extension module to CANopen external devices	Installed at the end of the last segment to connect standard CANopen devices	STBXBE2100	–

Designation	Use	Catalog number	Weight kg
Auxiliary power supply 24 V/5 V 1.2 A (1)	Additional power supply for logic of I/O modules	STBCPS2111	–

Bus extensions: mandatory separate parts

Designation	Used for	Catalog number	Weight kg
Module bases width 18.4 mm (0.72")	STB XBE 1000	STBXBA2400	0.028
	STB XBE 1200	STBXBA2300	0.033
	STB XBE 2100	STBXBA2000	0.028
	STB CPS 2111	STBXBA2100	0.033

Designation	Used for	Type	Sold in lots of	Catalog number	Weight kg
2-pin removable power connectors 24 V (2)	STB XBE 1200	Screw-type	10	STBXTS1120	–
		Spring-type	10	STBXTS2120	–
5-pin removable connectors (2)	STB XBE 2100	Screw-type	20	STBXTS1110	0.006
		Spring-type	20	STBXTS2110	0.006

Designation	Length	Catalog number	Weight kg
Island bus extension cables	0.3 m (0.32 yd)	STBXCA1001	–
	1.0 m (1.09 yd)	STBXCA1002	–
	4.5 m (4.92 yd)	STBXCA1003	–
	10.0 m (10.9 yd)	STBXCA1004	–
	14.0 m (15.3 yd)	STBXCA1006	–

Power supply additional to the 5 V 1.2 A integrated power supply built into the NIM network interface modules and the BOS bus extension module. It is installed in the primary segment or the extension segments.

(2) All STB XTS connectors can accommodate a flexible wire with maximum cross-section of 1.5 mm² (0.06"²), including cable end piece. For screw connectors, the maximum tightening torque is 0.25 Nm (2.21 lb-in).

Bus extensions: Optional separate parts

Designation	Used for	Type		Catalog number	Weight kg
Keying pin	Modules	–	60	STBXMP7700	–
	Removable connectors	–	96	STBXMP7800	–
Customizing labels (1)	I/O bases and modules	–	25 sheets	STBXMP6700	–
Insulated screwdriver 2.5 mm (0.098")	Screw-type removable connectors	Chrome vanadium steel	–	STBXTT0220	–

CANopen extension connector

STB XBE 2100: connection scheme (2)

The CANopen fieldbus interface is located on the front panel of the STB XBE 2100 extension module.

The pinout is as shown in the following table:

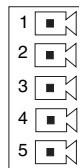

Pin	Signal
1	CAN ground (0 V)
2	CAN low bus signal
3	Optional CAN shielding
4	CAN high bus signal
5	No connection (3)

(1) Template for customizing labels:

- provided on the documentation mini CD-ROM supplied with the network interface modules.
- available from our website www.us.telemecanique.com.

(2) Observe all the recommendations in the "Hardware components reference guide for the Advantys STB system" included on the CD-ROM STB SUS 8800 or available from our website www.us.telemecanique.com.

(3) This pin is not connected and can be used as a 24V external device jumper.

Advantys™ STB Distributed I/O Solution

Power Distribution Modules

Presentation

The STB PDT ●105 **basic** PDM (*Power Distribution Modules*) provide power for the I/O module sensors and actuators (1) via the same bus 3.

Two basic power distribution modules are available:

- The STB PDT 3105 module is dedicated to providing power to I/O module sensors and actuators requiring a \approx 24 V power supply.
 - The STB PDT 2105 module is dedicated to providing power to I/O module sensors and actuators requiring a \sim 115/230 V power supply.
- Both models have 1 removable fuse.

The STB PDT ●100 **standard** power distribution modules provide power separately for the I/O module sensors and actuators (1) via the sensor bus 1 and the actuator bus 2.

Two standard power distribution modules are available:

- The STB PDT 3100 module is dedicated to providing power to the I/O module sensors and actuators requiring a \approx 24 V power supply.
 - The STB PDT 2100 module is dedicated to providing power to the I/O module sensors and actuators requiring a \sim 115/230 V power supply.
- Both models have 2 removable fuses.

Connection of power supplies

Three separate power supplies

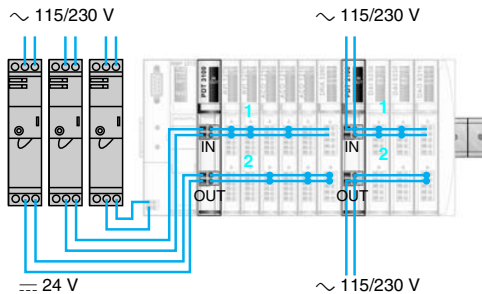

Configuration with standard PDM

This configuration allows:

- disconnection of the I/O power supply while maintaining the power supply to the NIM network interface module, and thus to the machine bus. For example: in a NIM INTERBUS configuration.
- isolation of the output power from the inputs to increase immunity to electromagnetic interference.
- power supply independent of the outputs allows connection of a Preventa™ safety module. If one of these outputs is disconnected, the inputs are still managed.

Power supplies of NIM module and of the separate inputs/outputs

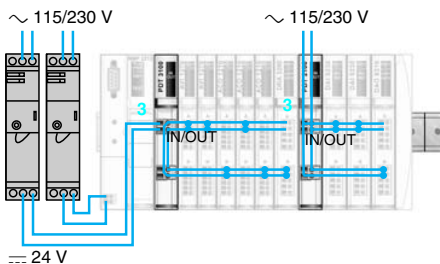

Configuration with basic PDM

This configuration allows disconnection of the I/O power supply while maintaining the power supply to the NIM network interface module, and thus to the machine bus. For example: in a NIM INTERBUS configuration.

(1) One power distribution module can supply power to both digital and analog I/O modules simultaneously.

Connection of power supplies (continued)

A single power supply

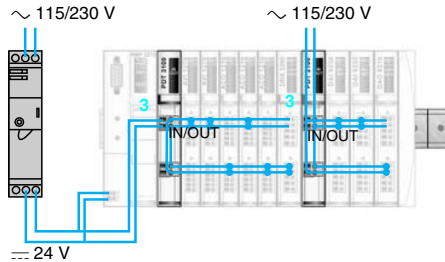

Configuration with basic PDM

Low-cost configuration with a single power supply for the NIM network interface module, sensor bus and actuator bus.

Choice of power distribution module determined by I/O modules

Power distribution module	Voltage	STB I/O modules					Application-specific	STB bus extension modules (1)
		Digital Inputs	Outputs Digital	Relay	Analog Inputs	Outputs		
STB PDT 3100	≡ 24 V	DDI 3230	DDO 3200	DRC 3210	AVI 1270	AVO 1250	EPI 1145 EPI 2145 EHC 3020	XBE 1000 XBE 1200 XBE 2100
		DDI 3420	DDO 3230	DRA 3290	ACI 1230	ACO 1210		
		DDI 3610	DDO 3410		ART 0200	AVO 1255		
		DDI 3425	DDO 3600		AVI 1255	AVO 1265		
		DDI 3615	DDO 3415		AVI 1275	ACO 1225		
		DDI 3725	DDO 3605		ACI 1225			
STB PDT 2100	~ 115 V	DAI 5230	DAO 8210	–	–	–		
	DAI 5260	DAO 5260						
STB PDT 2105	~ 230 V	DAI 7220	DAO 8210	–	–	–		
STB PDT 3105	≡ 24 V	DDI 3230	DDO 3200	DRC 3210	AVI 1270	AVO 1250	EPI 1145 EPI 2145 EHC 3020	
		DDI 3420	DDO 3230	DRA 3290	ACI 1230	ACO 1210		
		DDI 3610	DDO 3410		ART 0200	AVO 1255		
		DDI 3425	DDO 3600		AVI 1255	AVO 1265		
		DDI 3615	DDO 3415		AVI 1275	ACO 1225		
		DDI 3725	DDO 3605		ACI 1225			
STB PDT 2105	~ 115 V	DAI 5230	DAO 8210	–	–	–		
	DAI 5260	DAO 5260						
STB PDT 2105	~ 230 V	DAI 7220	DAO 8210	–	–	–		

(1) The STB bus extension modules can be connected after any power distribution module.

Advantys™ STB Distributed I/O Solution

Power Distribution Modules

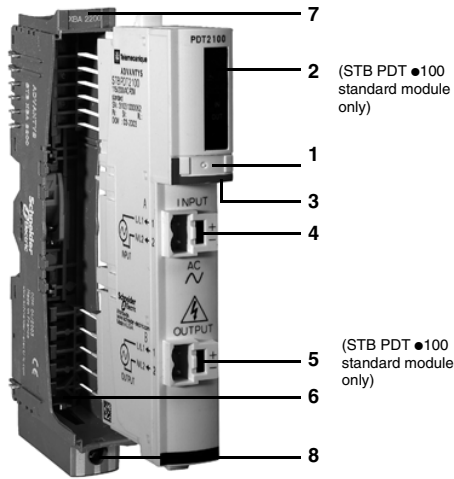

Description

The front panel of the Advantys STB PDT ●10● power distribution modules features:

1 A location for a customized label.

2 A status block with 2 display LEDs (STB PDT 2100/3100 standard module only):

Indication	Basic PDM modules	Standard PDM modules
Sensor bus power supply (1)	–	Green IN LED
Actuator bus power supply (1)	–	Green OUT LED

3 A color-coded module identification stripe (red for ~ 115/230 V, blue for --- 24 V).

4 A connector for removable screw-type connectors (STB XTS 1130) or spring-type connectors (STB XTS 2130) used to connect:

- the sensor power supply for STB PDT 2100/3100 standard modules.
- the sensor/actuator power supply for STB PDT 2105/3105 basic modules.

5 A connector for removable screw-type connectors (STB XTS 1130) or spring-type connectors (STB XTS 2130) used to connect the actuator power supply (STB PDT 2100/3100 standard module only).

To be ordered separately:

6 An STB XBA 2200 mounting base, width 18.4 mm (0.72").

This base features:

7 A location for a customized label.

8 A captive grounding screw.

The CD-ROM STB SUS 8800 contains two lots of documentation for the PDM power distribution modules in 5 languages:

- "System hardware components reference guide."
- "System planning and installation guide."

These documents can also be downloaded from www.us.telemecanique.com.

(1) IN/OUT LED lit: power supply present on digital I/O modules.

IN/OUT LED not lit: external power supply absent or removable fuse inside the PDM has blown. Consult the "System hardware components reference guide" included on the CD-ROM STB SUS 8800 or available from our website www.us.telemecanique.com.

Characteristics of power distribution modules						
Type of module			STB PDT 3100	STB PDT 2100	STB PDT 3105	STB PDT 2105
Range			Standard		Basic	
Power supply		V	--- 24 (1)	~ 115/230	--- 24	~ 115/230
Max. current	For inputs	A	4 at 30°C (86°F) 2.5 at 60°C (140°F)	5 at 30°C (86°F) 2.5 at 60°C (140°F)	–	–
	For outputs	A	8 at 30°C (86°F) 5 at 60°C (140°F)	10 at 30°C (86°F) 5 at 60°C (140°F)	–	–
	For inputs/outputs	A	–	–	4 at 30°C (86°F) 2.5 at 60°C (140°F)	
Sensor/actuator bus voltage range		V	--- 19.2...30 (2)	~ 85...265 (3)	--- 19.2...30	~ 85...265
Hot swapping			No			
Nominal consumption		mA	0 on --- 5 V logic power supply			
Reverse polarity protection			Yes, on the actuator bus	–	Yes, on the actuator bus	–
Built-in overcurrent protection	For inputs		By 5 A time-lag fuse (4)			
	For outputs		By 10 A time-lag fuse (4)		By 5 A time-lag fuse (4)	
Max. current on the grounding terminal		A	30 for 2 minutes			
Voltage-detect thresholds	IN/OUT LED lit		≥ --- 15 V ± 1 V	> ~ 70 V ± 5 V	–	
	IN/OUT LED not lit		< --- 15 V ± 1 V	< ~ 50 V ± 5 V	–	
Mounting base			STB XBA 2200 width 18.4 mm (0.72")			

- (1) Use a --- 24 V safety extra low voltage (SELV) external power supply.
 (2) DC power supplies may be shared or separate, or shared with the --- 24 V power supply of the network interface module.
 (3) AC power supplies of one and the same power distribution module originating from a three-phase transformer must be connected in the same phase.
 (4) Integrated fuse on the power distribution module. Can be replaced with the STB XMP 5600 fuse kit.

Characteristics of auxiliary and bus extension power supplies

Type of module		Auxiliary power supply: --- 24 V/--- 5 V	EOS internal bus extension	BOS internal bus extension	Bus extension to external CANopen devices
		STB CPS 2111	STB XBE 1000	STB XBE 1200	STB XBE 2100
Power supply	V	--- 24 Not isolated	–	--- 24 Not isolated	–
Connectors	Power supply	2-pin removable	–	2-pin removable	–
	Interface	–	Firewire	Firewire	5-pin removable
Input current	mA	400	–	400	–
Voltage limits	V	--- 19.2...30	–	--- 19.2...30	–
Output voltage	V	--- 5.25 ± 0.21 %	–	--- 5.25 ± 0.21 %	–
Output current	A	1.2 to --- 5 V	–	1.2 to --- 5 V	–
Isolation		No			
Immunity to electromagnetic interference (EMC)		Yes according to IEC61131-2			



STB XBA 2200



STB PDT 3100



STB XTS 1130



STB XTS 2130

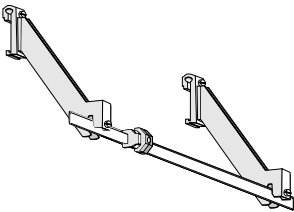

STB XSP 3000



STB XSP 3010/3020

Catalog numbers

Power distribution modules

Type of power supply	Voltage	Type	Catalog number	Weight kg
≡	24 V	Standard	STBPDT3100	0.130
		Basic	STBPDT3105	0.130
~	115/230 V	Standard	STBPDT2100	0.129
		Basic	STBPDT2105	0.129

Mandatory separate parts

Designation	Used for	Sold in lots of	Catalog number	Weight kg
Mounting base width 18.4 mm (0.72")	Mounting of STB PDT ●10● power supply modules on DIN rails	1	STBXBA2200	0.035
Field wiring connectors (2-pin) (1)	Screw-type	10	STBXTS1130	0.006
	Spring-type	10	STBXTS2130	0.006

Optional separate parts

Designation	Used for	Sold in lots of	Catalog number	Weight kg
Keying pins	Keying between power distribution module and base (sold in lots of 60)	–	STBXMP7700	–
	Keying between power distribution module and removable connectors (sold in lots of 24) (2)	–	STBXMP7810	–
Sheets of customizing labels (3)	Bases and modules	25	STBXMP6700	–
Grounding kit	Grounding for shielded cables 1 bar (1 m / 1.09 yd) and 2 lateral supports	1	STBXSP3000	–
Terminals for grounding kit	Cables with cross-section 1.5...6 mm ² (0.06 ...0.23" ²)	10	STBXSP3010	–
	Cables width 5...11 mm ² (0.19 ...0.43" ²)	10	STBXSP3020	–
Insulated screwdriver 2.5 mm (0.098")	Screw-type removable connectors	–	STBXTT0220	–

Phaseo® regulated, single-phase switching power supplies

Output voltage	Input voltage mains	Nominal power	Nominal current	Catalog number	Weight kg
≡ 24 V	100...240 V	48...240 W	2...10 A	See page 100	–

Replacement parts

Designation	Description	Catalog number	Weight kg
Fuses	5 A (lot of 5) and 10 A (lot of 5)	STBXMP5600	–

(1) All STB XTS ●●●● connectors can accommodate a flexible wire with maximum cross-section of 1.5 mm² (0.06" ²), including cable end piece. For screw connectors, the maximum tightening torque is 0.25 Nm (2.21 lb-in).

(2) Supplied with removable connectors STB XTS 1130/2130.

(3) A template for the customizing labels is supplied with the documentation mini-CD-ROM.

Advantys™ STB Distributed I/O Solution

Digital Input/Output Modules

Applications	Digital input modules
	Direct current



Voltage	--- 24 V			
Number of channels	2	4		
Sensor type	2 or 3-wire + ground	2 or 3-wire		
Inputs	Default logic	Positive		
	Configurable logic	Yes (1)	No	Yes (1)
	Type (IEC/EN 61131-2)	Type 2	Type 1+	
	Internal power supply for 3-wire sensors	Yes (2 outputs)	Yes (4 outputs)	
Response time	Off-to-on	610 µs @ 0.2 ms input filter time	3.5 ms	925 µs @ 0.5 ms input filter time
	On-to-off	625 µs @ 0.2 ms input filter time	3.8 ms	1.35 ms @ 0.5 ms input filter time
Filter time		0.2...16 ms	3 ms	0.5...16 ms
Connection	Two connectors (6 channel): STB XTS 1100 screw type or STB XTS 2100 spring type			
Base	STB XBA 1000			
PDM power distribution modules (2)	Voltage	--- 24 V		
	Catalog number	STB PDT 3100/3105		
Isolation	Field-to-bus	--- 1500 V for 1 minute		
	Channel-to-channel	-		
Protection against	Reverse polarity	Yes		
	Short circuit and overload	Yes, time-lag fuse on the PDM (Power Distribution Module)		
	Electronic protection of sensor power supplies	Yes	No	Yes
Module range	Standard	Basic	Standard	
Type of module	STB DDI 3230	STB DDI 3425	STB DDI 3420	
Page	46			

(1) Adjustable with STB SPU 1 configuration software.
 (2) Each voltage group requires its own PDM (Power Distribution Module).

Digital input modules

Direct current



--- 24 V

6	16
---	----

2-wire	2 or 3-wire
--------	-------------

Positive		
No	Yes (1)	No
Type 1		Type 3
No		Yes (4 outputs)

5.25 ms	1.21 ms	2 ms
---------	---------	------

5.75 ms	1.74 ms	2 ms
---------	---------	------

5 ms	1 ms
------	------

Two connectors (6 channels): screw-type STB XTS 1100 or spring-type STB XTS 2100	Two 18 channel connectors, STB XTS 1180 screw type or STB XTS 2180 spring type
--	--

STB XBA 1000	STB XBA 3000
--------------	--------------

--- 24 V

STB PDT 3100/3105

--- 1500 V for 1 minute

-

Yes

Yes, time-lag fuse on the PDM (Power Distribution Module)

No

Basic	Standard	Basic
-------	----------	-------

STB DDI 3615	STB DDI 3610	STB DDI 3725
--------------	--------------	--------------

46

Advantys™ STB Distributed I/O Solution

Digital Input/Output Modules

Applications		Digital output modules			
		For direct current (transistor)			
Voltage		--- 24 V			
Number of channels		2		4	
Outputs		Default logic Configurable logic Internal power supply for 3-wire actuators		Positive Yes Yes	
Load current		0.5 A		2 A	
Response time		Off-to-on On-to-off		620 μs @ 0.5 A load 575 μs @ 0.5 A load	
Fault recovery response		User-configurable setting (1)		Manual reset	
Fallback modes		User-configurable setting (1)		All channels to 0	
Connection		Two connectors (6 channels): STB XTS 1100 screw type or STB XTS 2100 spring type			
Base		STB XBA 1000			
PDM power distribution modules (2)		Voltage Catalog number		--- 24 V STB PDT 3100/3105	
Isolation		Field-to-bus Channel-to-channel		--- 1500 V for 1 minute --- 500 V for 1 minute	
Protection against		Reverse polarity Short circuit and overload Electronic protection of actuator power supplies		Yes Yes (3) Yes	
Module range		Standard		Basic	
Type of module		STB DDO 3200		STB DDO 3230	
				STB DDO 3415	
				STB DDO 3410	
Page		46			

(1) Requires STB SPU 1 configuration software.
 (2) Each voltage group requires its own PDM (Power Distribution Module).
 (3) Via built-in time-lag fuses on the PDM (Power Distribution Module).
 (4) If external power supply: 2.5 A time-lag fuses recommended on each channel, to be supplied by the user.

Digital output modules

For direct current (transistor)



~ 24 V

6

16

Positive

No

Yes

No

No

No

0.25 A

0.5 A

up to 0.5 per channel

550 μ s @ 250 mA load

715 μ s @ 0.5 A load

2 ms @ 0.5 A load

900 μ s @ 250 mA load

955 μ s @ 0.5 A load

2 ms @ 0.5 A load

Manual reset

User-configurable (1)

Manual reset

All channels to 0

User-configurable (1)

All channels to 0

Two connectors (6 channels): STB XTS 1100 screw type or STB XTS 2100 spring type
STB XBA 1000

Two connectors (18 channels): screw-type STB XTS 1180 or spring-type STB XTS 2180
STB XBA 3000

~ 24 V

STB PDT 3100/3105

~ 1500 V for 1 minute

-

Yes

Yes (3)

No

Basic

Standard

Basic

STB DDO 3605

STB DDO 3600

STB DDO 3705

46

Advantys™ STB Distributed I/O Solution

Digital Input/Output Modules

Applications		Digital input modules		
		Alternating current		
Voltage		~ 115 V		~ 230 V
Number of channels		2		
Sensor type		2 or 3-wire + ground	2-wire	2 or 3-wire + ground
Inputs	Default logic	–		
	Configurable logic	Yes (1)		
	Type (IEC/EN 61131-2)	Type 1		
	Internal power supply for 3-wire sensors	Yes		
Response time	Off-to-on	1.5 line cycles		
	On-to-off	1.5 line cycles		
Filter time		–		
Connection		Two connectors (5 channels): screw-type STB XTS 1110 or spring-type STB XTS 2110		
Base		STB XBA 2000		
PDM power distribution modules (2)	Voltage	~ 115 V	~ 115 V external source	~ 230 V
	Catalog number	STB PDT 2100/2105		
Isolation	Field-to-bus	~ 1780 V for 1 minute		
	Channel-to-channel	–	~ 1780 V for 1 minute	–
Protection against	Reverse polarity	Yes		
	Short circuit and overload	Yes, 5 A time-lag fuse on the PDM (Power Distribution Module)		
	Electronic protection of sensor power supplies	Yes	No	Yes
Module range		Standard		
Type of module		STB DAI 5230	STB DAI 5260	STB DAI 7220
Page		46		

(1) Requires STB SPU 1 configuration software.
 (2) Each voltage group requires its own PDM (Power Distribution Module).
 (3) Via built-in time-lag fuses on the PDM (Power Distribution Module).
 (4) Recommended user-supplied 2.5 A time-lag fuses on each channel.
 (5) 2.5 A, 250 V fuses required on each channel, to be supplied by the user.

Advantys™ STB Distributed I/O Solution

Digital Input/Output Modules

Applications		Digital output modules			
		For direct/alternating current (relay)		For alternating current (triac)	
					
Voltage		--- 24 V (relay contact) ~ 115/230 V (relay contact)		~ 115 V	~ 115/230 V
Number of channels		2 form C (N.O/N.C) relays	2 form A/B relays	2	
Outputs		Default logic Configurable logic Internal power supply for 3-wire actuators		Positive	–
		–		Yes (1)	–
		No		Yes	
Load current		2 A per contact	7 A per contact	2 A at 30°C (86°F) 1 A at 60°C (140°F)	
Response time				0.5 line cycles	10 ms
		Off-to-on	5.25 ms	10 ms	10 ms
		On-to-off	6.75 ms	10 ms	10.5 ms
Fault recovery response		Manual reset		Automatic reset	User-configurable(1)
Fallback modes		User-configurable (1)			
Connection		Two connectors (5 channels) : STB XTS 1100 screw type or STB XTS 2110 spring type			
Base		STB XBA 2000	STB XBA 3000	STB XBA 2000	
PDM power distribution modules (2)		Voltage Catalog number		–	~ 115/230 V
		--- 24 V (relay coil) STB PDT 3100/3105		–	STB PDT 2100/2105
Isolation		Field-to-bus Channel-to-channel		~ 1780 V for 1 minute	
		~ 500 V for 1 minute		~ 1780 V for 1 minute	–
Protection against		Reverse polarity Short circuit and overload Electronic protection of actuator power supply		Yes	Yes (3)
		–		(5)	Yes (3)
		Yes (3)		No	No
Module range		Standard			
Type of module		STB DRC 3210	STB DRA 3290	STB DAO 5260	STB DAO 8210
Page		46			

Presentation

Advantys STB digital input/output modules consist of:

- Input modules.
- Static output modules.
- Relay output modules.

The range of basic digital I/O modules comprises :

- 3 digital input modules:
 - 4, 6 and 16 input channels --- 24 V.
- 3 digital output modules:
 - 4, 6, and 16 output channels --- 24 V.

The range of standard digital I/O modules comprises:

- 6 digital input modules:
 - 2, 4 and 6 input channels --- 24 V.
 - 2 input channels ~ 115 V (2 modules).
 - 2 input channels ~ 230 V.
- 6 digital output modules:
 - 2 output channels --- 24 V (2 modules).
 - 4 and 6 output channels --- 24 V.
 - 2 output channels ~ 115 V.
 - 2 output channels ~ 115/230 V.
- 2 relay output modules:
 - 2 relays with 1 "NO" contact and 1 "NC" contact.
 - 2 relays with 1 "NO/NC" contact.

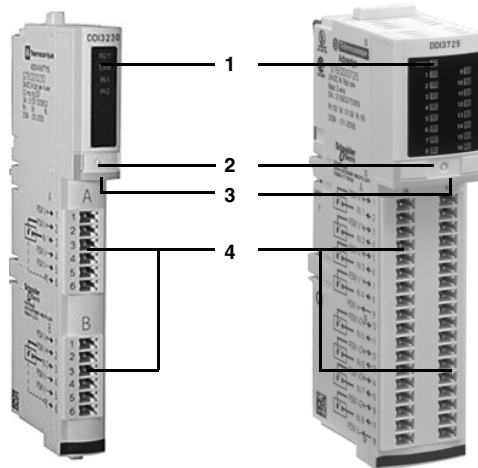

Description

The front panel of a digital I/O module features:

- 1 An LED display block providing the following indications:

Indication	Basic I/O modules	Standard I/O modules
Module status: ready, pre-operational, operational	Green RDY LED	Green RDY LED
Module error (1)	– (2)	Red ERR LED
Status of each channel	Green LEDs IN1 to IN16 or OUT1 to OUT16 depending on module	Green LEDs IN1 to IN16 or OUT1 to OUT16 depending on module

- 2 Place for user to insert his own label STB XMP 6700.
- 3 A color-coded module identification stripe. See color codes on page 6.
- 4 Two connectors for screw- or spring-type terminals.

(1) RDY is on permanently if the module is operational and flashes in different ways in the other states.

If ERR is lit or flashing, there is a fault on this module.

For information about the signaling of module and channel states, consult the "System hardware components reference guide" included on the CD-ROM STB SUS 8800 or available from our website www.us.telemecanique.com.

(2) Basic I/O modules: A module error is signaled by the ERR LED of the NIM network interface module of the island.

Description (continued)

Mandatory items to be ordered separately

I/O module bases in 3 widths depending on modules:

Module size	Width	Base catalog number
1	13.9 mm (0.547")	STBXBA1000
2	18.4 mm (0.72")	STBXBA2000
3	28.1 mm (1.10")	STBXBA3000

These bases have:

- a place for a customized label STB XMP 6700 (1)
- 4 locations for placing module/base keying pins (1)

Removable connectors

Connector type (2 connectors per module)	5 pins	6 pins	18 pins
Screw terminals	STBXTS1110 (sachet of 20)	STBXTS1100 (sachet of 20)	STBXTS1180 (sachet of 2)
Spring terminals	STBXTS2110 (sachet of 20)	STBXTS2100 (sachet of 20)	STBXTS2180 (sachet of 2)

These removable connectors have between 5 and 18 possible ways of coding the module/connector keying pins (1).

Optional items to be ordered separately

Mechanical keying pins and identifiers

These devices ensure that each I/O module, its base and its wiring connectors are properly matched after dismantling or replacement.

Keying between module and base (1)	Keying between module and connectors (1)	Module identification (2)	Base identification (2)
STBXMP7700	STBXMP7800	STBXMP6700	STBXMP6700

Customizing labels STB XMP 6700 make it much easier to recognize I/O modules and their bases.

External cable shielding connector

This optional device allows quick and easy connection of external cable shielding (1).

Connection and shielding kit Lateral supports and metal bar, length 1m	Terminals for grounding kit
Cable clamp size 1 (sachet of 10) for shielded cable with external diameter 1.5 to 6.5 mm ² (0.06 to 0.25" ²)	STBXSP3020
Cable clamp size 2 (sachet of 10) for shielded cable with external diameter 5 to 11 mm ² (0.19 to 0.43" ²)	

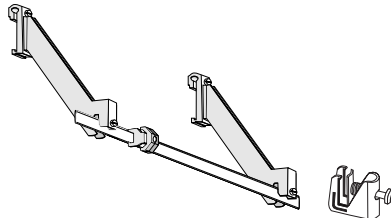

STB XSP 3000

STB XSP 3010/3020

Digital input modules and digital output modules (— 24 V, ~ 115/220 V and 2A relay) include a ground connection which makes this accessory optional in those cases. For analog modules, it is advisable to this device as it allows quick and easy connection of external cable shielding (1).

(1) To find out:

- the coding of keying pins
 - how to use the CEM kit
- consult the system planning and installation guide included on the CD-ROM STB SUS 8800 or available on our website www.us.telemecanique.com.

(2) Template file for printing labels on a laser printer (color or black and white) or manual marking with indelible felt pen: included on the mini CD-ROM supplied with each NIM network interface module or available from our website www.us.telemecanique.com.

Operating modes of digital output modules

Output protection and reset following overload or short-circuit

Digital output module Advantys STB	Protection against short-circuit and thermal overload	Actuator power supply protection	Reset	Diagnostics
Basic modules STB DDO 3415, 3605, 3705	Internal electronic	Via PDM fuse	On elimination of the fault	Per group of 2 channels
Standard modules STB DDO 3200, 3230 Actuator powered by the module	Internal electronic	Internal electronic	User-configurable (1)	Per channel
Standard modules STB DDO 3200, 3230 Actuator powered externally	Internal electronic	Via external fuse	User-configurable (1)	Per channel
Standard modules STB DDO 3410, 3600	Internal electronic	–	–	Per group of 2 channels
Standard modules STB DRC 3210, STB DRA 3290	External fuse	–	User-configurable (1)	–
Standard modules STB DAO 8210	External fuse	Via PDM fuse	User-configurable (1)	–
Standard modules STB DAO 5260	External fuse	–	User-configurable (1)	–

Behavior of digital output modules upon internal communication fault on the island or between PLC and NIM

Digital output STB module	Output fallback
Basic modules STB DDO 3415, 3605, 3705	0 (open output)
Standard modules STB DDO 3200, 3230, 3410, 3600 STB DRC 3210, STB DRA 3290 STB DAO 8210, STB DAO 5260	User-configurable (2)

(1) Reset is user-configurable: automatic on elimination of the fault (factory-configured by default) or voluntary by the PLC.

Each model is independently configurable. This operation requires the configuration software Advantys STB SPU 1●●●.

The tripping data is transmitted to the PLC via the NIM network interface module.

(2) The fallback state is user-configurable: to 0 (factory-configured by default), to 1, or to "hold last value" for "warm standby" and "hot standby" applications.

Each output channel of each module is independently configurable.

This operation requires the configuration software Advantys STB SPU 1●●●.

Advantys™ STB Distributed I/O Solution

Digital Input/Output Modules

Hot swapping and cold swapping of output modules			
Swapping	Hot swap:		Cold swap
	Basic NIM	Standard NIM (3)	
Basic digital output module	The other I/O modules remain operational (1)	The other I/O modules remain operational (2)	All I/O modules and PDM power distribution modules can be removed from the island. The removable connectors facilitate operation.
Standard digital output module not configured, "mandatory"	The other I/O modules remain operational (1)	The other I/O modules remain operational (1) (2)	
Standard digital output module configured, "mandatory"	The other I/O modules remain operational (1)	Output fallback according to configuration (2) (3) Island in pre-operational mode. Inputs are no longer updated on the network/fieldbus.	
PDM power distribution module	Illegal	Illegal	

(1) The configuration software STB SPU 1●●● cannot be connected to a basic NIM. Any basic or standard I/O module is reconfigured according to factory default parameters.

(2) The configuration software STB SPU 1●●● can be connected via a standard NIM. All standard I/O modules can be configured. Basic modules are not configurable (factory default settings only).

(3) For standard digital output modules, the fallback state is configurable:

- Fallback to level 0.
- Fallback to level 1.
- Fallback to a predefined level of the output range for analog modules.
- Hold last value.

Characteristics of DC digital input modules							
Type of module	STB	DDI 3230	DDI 3425	DDI 3420	DDI 3615	DDI 3610	DDI 3725
Range		Standard	Basic	Standard	Basic	Standard	Basic
Number of channels		2	4		6		16
Input nominal values Voltage	V	--- 24					
Type (IEC/EN 61131-2)		Type 2	Type 1+		Type 1		Type 3
Input limit values Frequency	Hz	-					
At state 1	Voltage	--- 11...30			--- 15...30		--- 11...30
	Min. current	6	2.5		2		
At state 0	Voltage	--- - 3...+ 5					
	Max. current	2	1.2		0.5		1.5
Input voltage values Permanent voltage	V	--- 30					
Absolute maximum voltage	V	--- 56 for 1.3 ms, decaying pulse					
Typical input current (at --- 24 V)	mA	7.5	8		4.5		
Input logic Default		Positive on each channel					
User-configurable setting (1)		Positive or negative, selection by channel	-	Positive or negative, selection by channel	-	Positive or negative, selection by channel	-
Input response time Off-to-on	ms	0.610 with input filter time of 0.2	3.5	0.925 with input filter time of 0.5	5.25	1.21	2.0
On-to-off	ms	0.625 with input filter time of 0.2	3.8	1.35 with input filter time of 0.5	5.75	1.74	2.0
Swapping Cold swap		Yes					
Hot swap		Yes, depending on NIM and mandatory nature of module. See table on page 41					
Reverse polarity protection		Yes					
Isolation Field-to-bus	V	--- 2000 for 1 minute	--- 1500 for 1 minute				
Channel-to-channel	V	-					
Input protection		Resistor-limited					
Current supplied by sensor Electronic short-circuit protection (SCP)	mA	100 per channel	50 per channel	100 per channel	-		
Input filter Default	ms	1	3	1	5	1	
User-configurable setting (1)	ms	0.20 0.50 1 2 4 8 16	-	0.50 1 2 4 8 16	-		
Tolerance	ms	± 0.1	-	± 0.25	-		
I/O base		STB XBA 1000					XBT XBA 3000
PDM power distribution module Voltage	V	--- 24					
Model		STB PDT 3100/3105					
Power protection		Integrated time-lag fuse on PDM(2)					
Logic bus current consumption --- 5 V	mA	70	60		70		150

(1) Requires configuration software Advantys STB SPU 1000.

(2) Basic module: 5 A fuse.
Standard module: 10 A fuse.

Characteristics of DC digital output modules										
Type of module		STB	DDO 3200	DDO 3230	DDO 3415	DDO 3410	DDO 3605	DDO 3600	DDO 3705	
Range			Standard		Basic	Standard	Basic	Standard	Basic	
Number of channels			2		4		6		16	
Nominal values of outputs	Voltage	V	--- 24							
	Current/channel	A	0.5	2	0.25	0.5	0.25	0.5		
Output logic	Default		Positive for each channel							
	User-configurable setting (1)		(2)		–	(2)	–	(2)	–	
Output voltage values	Permanent voltage	V	--- 19.2...30							
	Absolute maximum voltage	V	--- 56 for 1.3 ms, decaying voltage pulse							--- 35 for 1.3 ms, decaying voltage pulse
Response time	Off-to-on		620 µs at a load of 0.5 A	520 µs	560 µs at load of 0.25 A	560 µs at load of 0.5 A	550 µs at load of 0.25 A	715 µs at load of 0.5 A	2 ms at load of 0.5 A	
	On-to-off		575 µs at load of 0.5 A	720 µs	870 µs at load of 0.25 A	870 µs at load of 0.5 A	900 µs at load of 0.25 A	955 µs at load of 0.5 A	2 ms at load of 0.5 A	
Swapping	Cold swap		Yes							
	Hot swap		Yes, depending on NIM and mandatory nature of module. See table on page 41							
Reverse polarity protection			Yes							
Isolation	Field-to-bus	V	--- 1500 for 1 minute							
	Channel-to-channel	V	–	---1500 for 1 minute	–					
Electronic protection of outputs against short-circuits and thermal overloads			Per group of 2 channels							Per group of 8 channels
	Feedback		Per channel	2 per channel, 4 or 6 per group (2 channels per group)					Per group of 8 channels	
	Reset		Resetting configurable with standard output modules and tripping data transmitted to NIM network interface module. Automatic resetting on elimination of the fault with basic output modules (4)							
Leakage current (at state 0)		mA	0.4 to --- 30 V max.	1 to --- 30 V max.	0.4 to --- 30 V max.					
Maximum surge current		A	5 to 500 µs (up to 6 per minute)	10 to 500 µs (up to 6 per minute)	2.5 to 500 µs (up to 6 per minute)	5 to 500 µs (up to 6 per minute)	2.5 to 500 µs (up to 6 per minute)	5 to 500 µs (up to 6 per minute)	Automatic limit per channel	
Maximum load	Capacity	µF	50							10
	Inductance		0.5 H at a switching frequency of 4 Hz L = 0.5/I ² x F (5)							1.0 at 4 Hz
Minimum load current		mA	0.5	2	–	0.5	–	0.5	–	
Fallback on COM fault	Default state		0 on all channels							
	User-configurable (1)		Yes (6)			–	Yes (6)	–		
Reset on COM fault	Default state		Manual reset by user required							
	User-configurable (1)		Yes (7)			–	Yes (7)	–		
I/O base			STB XBA 1000							STB XBA 3000
PDM power distribution module	Voltage	V	--- 24							
	Model		STB PDT 3100/3105							
	Power protection		Integrated time-lag fuse on PDM(8)	(9)	Integrated time-lag fuse on PDM (8)					
Logic bus current consumption --- 5 V		mA	60		80		90		150	

(1) Requires configuration software Advantys STB SPU i●●●.

(2) Positive or negative, selection by channel.

(3) With standard NIM module only.

(4) For basic module STB DDO 3705: automatic reset by groups of 8 channels, 1...8 and 9...16.

(5) L = load inductance (H), I = load current (A), F = switch frequency (Hz).

(6) Fallback state: hold last value, set to predefined value (0 or 1) on each channel individually.

(7) Manual or automatic reset, configurable for standard output modules on an island equipped with a standard NIM module.

(8) Standard modules: 10 A fuse, basic modules: 5 A fuse.

(9) 2.5 A time-lag fuses supplied by the user, recommended on each channel.

Characteristics of AC digital input modules

Type of module			STB DAI 5230	STB DAI 5260	STB DAI 7220
Range			Standard		
Number of channels			2		
Input nominal values	Voltage	V	~ 115, (50/60 Hz)		~ 230 (50/60 Hz)
Type (IEC/EN 61131-2)			Type 1		
Input logic	Default		–	Positive	–
	User-configurable setting (1)		–	Yes, per channel (1)	–
Input response time	Off-to-on	ms	1.5 network period		
	On-to-off	ms	1.5 network period		
Input limit values	Frequency	Hz	47 to 63		
	At state 1	Voltage	V	~ 74... 132	~ 159... 256
		Min. current	mA	4	
	At state 0	Voltage	V	~ 0...20	~ 0...40
		Max. current	mA	2	
Input voltages	Permanent voltage	V	~ 132	~ 265	
		V	~ 200 for 1 cycle	~ 400 for 1 cycle	
Swapping	Cold swap		Yes		
	Hot swap		Yes, depending on NIM and mandatory nature of module. See table on page 41		
Reverse polarity protection			–		
Isolation	Field-to-bus	V	~ 1780 for 1 minute		
	Channel-to-channel	V	–	~ 1780 for 1 minute	–
Input protection			Resistor-limited	Metal oxide varistor limited	Resistor-limited
Current supplied by sensor (electronic short-circuit protection)		mA	60 max.	–	
Input filter	Default	ms	–		
	User-configurable setting (1)	ms	–		
	Tolerance	ms	–		
I/O base			STB XBA 2000		
PDM power distribution module	Voltage	V	~ 115/230		
	Model		STB PDT 2100/2105		
	Power protection	A	Integrated time-lag fuse on PDM (3)	External 0.5 A fuse required	Integrated time-lag fuse on PDM (3)
Logic bus current consumption --- 5 V		mA	50		

(1) Requires configuration software Advantys STB SPU 1●●●.

(2) Basic NIM modules do not support hot swapping of input/output modules.

(3) Basic module: 5 A fuse.

Standard module: 10 A fuse.

Advantys™ STB Distributed I/O Solution

Alternating current and relay digital output modules

Characteristics of AC and relay output modules						
Type of module		STB DRC 3210	STB DRA 3290	STB DAO 5260	STB DAO 8210	
Range		Standard				
Number of channels		2 "NO/NC"	2 "NO" and "NC"	2		
Output nominal values	Voltage	V	∓ 24, ∼ 115/230		∼ 115	∼ 115/230
	Current per channel/contact	A	2 at ∓ 24 V	7 at ∓ 24 V	2 at 30°C (86°F)	
			2 at ∼ 230 V	7 at ∼ 230 V	1 at 60°C (140°F)	
Output logic	Default		Positive on both channels			
	User-configurable setting (2)		Positive or negative by channel			
Voltage limits	Permanent	V	∓ 5...30, ∼ 20...250		∼ 74...132	∼ 20...265
	Absolute maximum	V	–		∼ 132	∼ 300 for 10 s ∼ 400 for 1 cycle
Response time	Off-to-on		5.25 ms	10 ms	0.5 period ∼	10 ms
	On-to-off		6.75 ms	10 ms	0.5 period ∼	10.5 ms
Switching capability		VA	600 (resistive load)	2100 (resistive load)	–	
Relay contact life	Mechanical		10 ⁶ operations		–	
	Electrical		10 ⁵ operations (resistive load at max. voltage and current)		–	
Swapping	Cold swap		Yes			
	Hot swap		Yes, depending on NIM and mandatory nature of module. See table on page 41			
Isolation	Between channels and logic bus	V	∼ 1780 for 1 minute			
	Channel to channel	V	∼ 500 for 1 minute		∼ 1780 for 1 minute	–
	Logic bus to actuator bus	V	∓ 1500 for 1 minute			–
Output surge protection (internal)			Yes, by GMOV (300 V rms, ∓ 385 V, 400 Joules max. for 20 μs, 0.1 W max.) (1)		External 5 A fuse required	Transient voltage by varistor and RC.
Leakage current (at state 0)		mA	–		2 at ∼ 132 V max.	2.5 at ∼ 230 V 2 at ∼ 115 V
Maximum surge current per relay/channel		A	Capacitive load of 20 at t = 10 ms		30 over 1 period 20 over 2 periods	
Minimum load current		mA	50		1	5
Fallback on COM fault	Default state		2 coils de-energized		0 on both channels	
	User-configurable (2)		Fallback state: hold last value or set to predefined value (0 or 1) on each channel individually.			
Reset on COM fault	Default state		Manual reset by user required			
	User-configurable (2)		–		Manual or automatic resetting	
I/O base			STB XBA 2000	STB XBA 3000	STB XBA 2000	
PDM power distribution module	Coil voltage	V	∓ 24		–	
	Model		STB PDT 3100/3105		STB PDT 2100/2105	
	Coil protection		10 A time-lag fuse on PDM		–	
Logic bus current consumption ∓ 5 V		mA	60	70		

(1) For greater protection, an RC circuit, a free-wheel diode or a GMOV peak limiter circuit appropriate to the voltage should be mounted in parallel across the terminals of each actuator.
 (2) Requires configuration software Advantys STP SPU 1●●●.



STB DDI 3230



STB DDO 3200



STB DRC 3210



STB DRA 3290

Catalog numbers

Basic digital input modules

Input voltage	Number of channels	Compliance IEC/EN 61131-2	Catalog number	Weight kg
=24 V	4	Type 1+	STBDDI3425	0.111
	6	Type 1	STBDDI3615	0.112
	16	Type 3	STBDDI3725	0.086

Standard digital input modules

Input voltage	Number of channels	Compliance IEC/EN 61131-2	Catalog number	Weight kg
=24 V	2	Type 2	STBDDI3230	0.110
	4	Type 1+	STBDDI3420	0.111
	6	Type 1	STBDDI3610	0.112
~ 115 V	2	Type 1	STBDAI5230	0.120
~ 115 V (external source)	2 (isolated)	Type 1	STBDAI5260	0.065
~ 230 V	2	Type 1	STBDAI7220	0.122

Basic digital output modules

Output voltage	Output current	Number of channels	Compliance IEC/EN 61131-2	Catalog number	Weight kg
= 24 V	0.25 A	4	Yes	STBDDO3415	0.110
		6	Yes	STBDDO3605	0.114
	0.5 A	16	Yes	STBDDO3705	0.086

Standard digital output modules

Output voltage	Output current	Number of channels	Compliance IEC/EN 61131-2	Catalog number	Weight kg
= 24 V	0.5 A	2	Yes	STBDDO3200	0.112
		2	Yes	STBDDO3230	0.116
	0.5 A	4	Yes	STBDDO3410	0.110
		6	Yes	STBDDO3600	0.114

Standard relay output modules

Output voltage	Output current	Number of channels	Compliance IEC/EN 61131-2	Catalog number	Weight kg
= 24 V or ~ 115/230 V (relay)	2 A	2	Yes	STBDRC3210	0.130
	7 A	2	Yes	STBDRA3290	0.130

Standard triac output modules

Output voltage	Output current	Number of channels	Compliance IEC/EN 61131-2	Catalog number	Weight kg
~ 115 V	2 A	2 (isolated)	Yes	STBDAO5260	0.067
~ 115/230 V	2 A	2	Yes	STBDAO8210	0.125



STB XBA 1000



STB DDI 3230



STB DDO 3200



STB XBA 2000



STB DRC 3210



STB XBA 3000



STB DRA 3290

Catalog numbers (continued)

Mandatory separate parts

Description	Base width	For I/O modules	Catalog number	Weight kg
I/O bases	13.9 mm (0.54")	STB DDI STB DDO	STBXBA1000	0.024
	18.4 (0.72")	STB DAI STB DAO STB DRC	STBXBA2000	0.028
	28.1 mm (1.10")	STB DRA	STBXBA3000	0.048

Description	Characteristics	Connection type	For I/O modules	Catalog number	Weight kg
Removable connectors Sold in lots of 20 (1)	6 contacts	Screw-type	STB DDI STB DDO	STBXTS1100	0.006
		Spring-type	STB DDI STB DDO	STBXTS2100	0.006
	5 contacts	Screw-type	STB DAI STB DAO STB DRC STB DRA	STBXTS1110	0.006
		Spring-type	STB DAI STB DAO STB DRC STB DRA	STBXTS2110	0.006

Removable connectors Sold in lots of 2 (1)	18 contacts	Screw-type	STB DDI 3725 STB DDO 3705	XBXTS1180	0.047
		Spring-type	STB DDI 3725 STB DDO 3705	STBXTS2180	0.034

Optional separate parts

Description	Use	Sold in lots of	Catalog number	Weight kg
Keying pins	Modules	60	STBXMP7700	–
	For removable connectors	96	STBXMP7800	–
Sheets of customizing labels (2)	I/O bases and modules	25	STBXMP6700	–

(1) All connectors can accommodate a flexible wire with maximum cross-section of 1.5 mm² (0.06"²), including cable end piece. For screw connectors, the maximum tightening torque is 0.25 Nm (2.21 lb-in).

(2) A template for producing customized labels is supplied on the documentation mini-CD-ROM.

Connections

Direct current digital input modules

STB DDI 3230

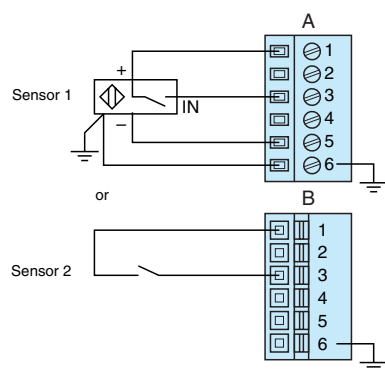

STB DDI 3420/3425

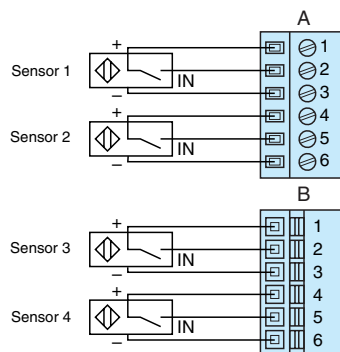

STB DDI 3610/3615

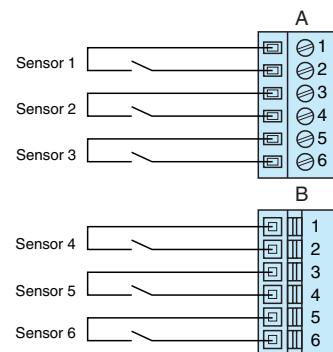

STB DDI 3725

16 two-wire sensors

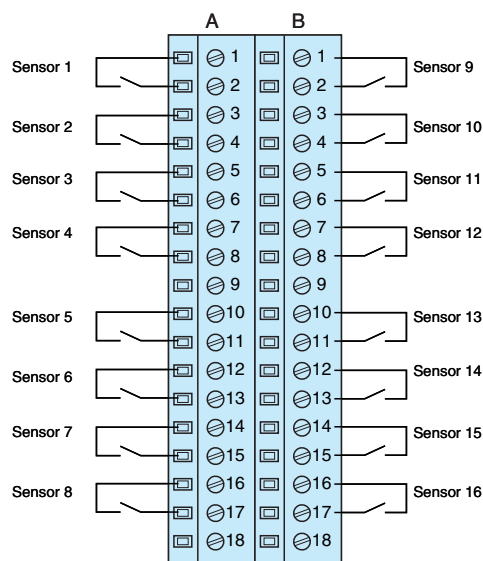

1 three-wire sensor per input group (1)

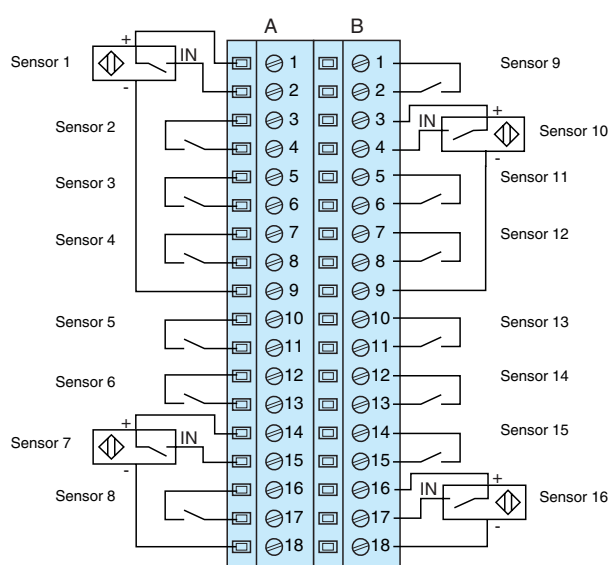

(1) Group 1: contacts 1 to 9 on connector A.
 Group 2: contacts 10 to 18 on connector A.
 Group 3: contacts 1 to 9 on connector B.
 Group 4: contacts 10 to 18 on connector B.

Connections (continued)

Alternating current digital input modules

STB DAI 5230

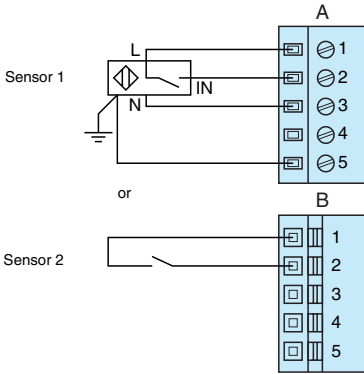

STB DAI 5260

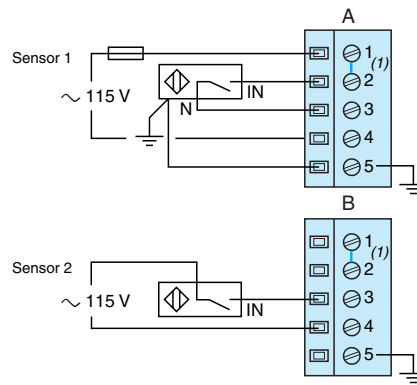

(1) Link internal to module

STB DAI 7220

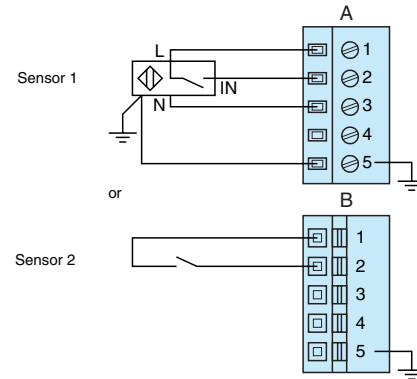

Connections (continued)

Direct current digital output modules

STB DDO 3200

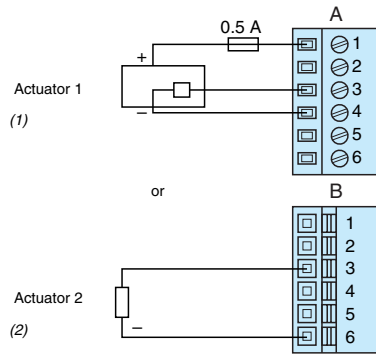

STB DDO 3230

1 three-wire actuator and 1 two-wire actuator with external ± 24 V power supply

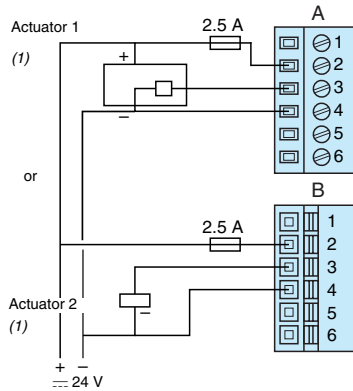

2 two-wire actuators powered via PDM

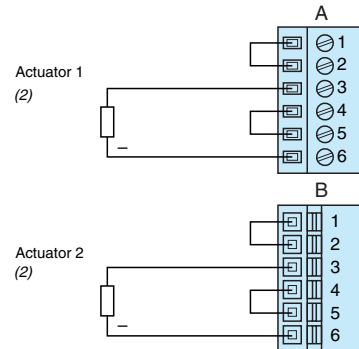

STB DDO 3410/3415

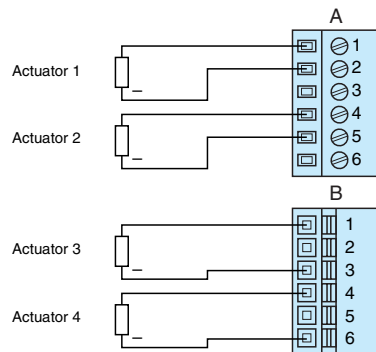

STB DDO 3705

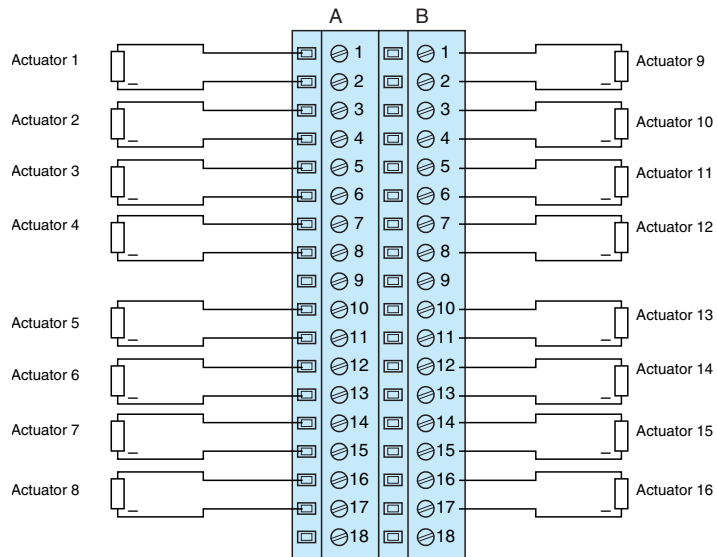

STB DDO 3600/3605

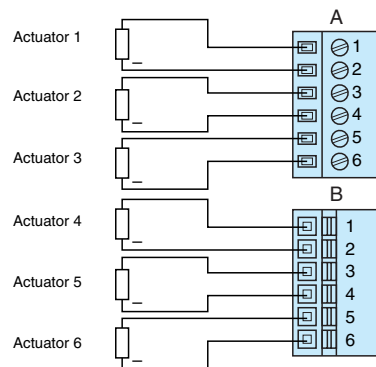

(1) Actuator protected by external fuse (depending on use).

(2) Actuator protected by integrated fuse on power distribution module (10 A fuse with STB PDT 3100/2100 or 5 A fuse with STB PDT 3105/2105).

Connections (continued)

Alternating current digital output modules

STB DAO 5260

STB DAO 8210

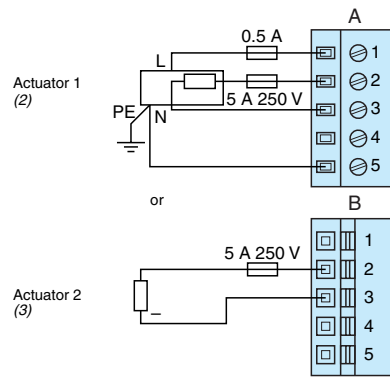
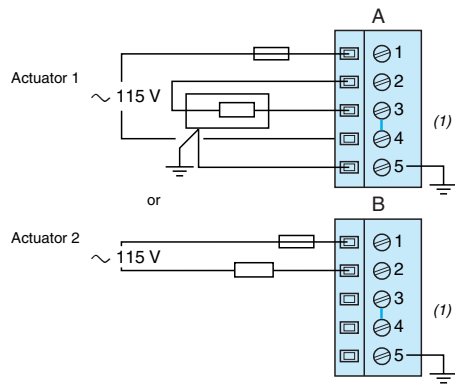

Direct/alternating current (relay) digital output modules

STB DRC 3210

STB DRA 3290

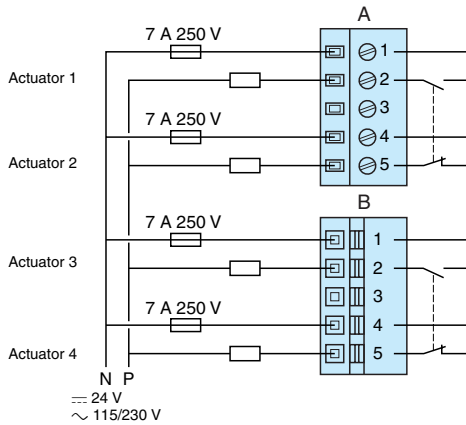
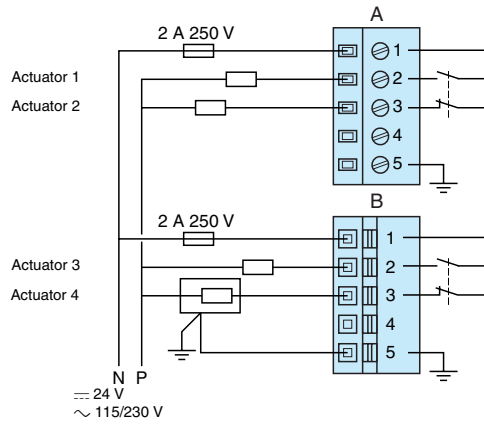

(1) Link internal to module.

(2) Actuator protected by external fuse (depending on use).

(3) Actuator protected by integrated fuse on power distribution module (10 A fuse with STB PDT 3100/2100 or 5 A fuse with STB PDT 3105/2105).

Advantys™ STB Distributed I/O Solution

Analog input modules

Applications	Analog input modules
	Voltage



Number of channels	2		
Range	0...10 V		- 10...+ 10 V
Resolution	10 bits	9 bits + sign	11 bits + sign
Response time	5 ms for both channels		
Acquisition period	-		
Acquisition or update time	10 ms for both channels		
Internal power supply for 3-wire inputs	Yes		
Connections	Two STB XTS 1100 screw-type connectors or STB XTS 2100 spring-type connectors (6-channel)		
Base	STB XBA 1000		
PDM power distribution modules (1)	Voltage	... 24 V	
	Catalog number	STB PDT 3100/3105	
Isolation	Field-to-bus	... 1500 V for 1 minute	
	Channel-to-channel	... 30 V (when sensor voltage is separate from logic bus voltage)	
Fallback states	-		
Protection against	Reverse polarity	Yes	
	Short circuit and overload	Yes, time-lag fuse on the PDM power distribution module	
	Electronic protection of sensor power supply	No	Yes
	Cut sensor wire detection	No	Yes (2)
Range	Basic		Standard
Type of module	STB AVI 1255	STB AVI 1275	STB AVI 1270

Page	62
------	----

(1) One PDM (Power Distribution Module) is required per voltage group.
 (2) Requires software Advantys STB SPU 1●●●.

Analog input modules

Current

Multi range



2		4		2
4...20 mA	0...20 mA	4...20 mA and 0...20 mA	4...20 mA, 0...20 mA and HART protocol tolerant	Thermocouples B, E, J, K, R, S and T Temperature probe Pt 100, Pt 1000, Ni 100, Ni 1000, Cu 10 ± 80 mV
10 bits	12 bits	15 bits + sign		
5 ms for both channels		8 ms for 4 channels	80 ms for 4 channels	–
–		150... 360 ms (depending on the range)		
10 ms for both channels		10 ms for 4 channels	85 ms for 4 channels	10 ms for both channels
Yes		No		
Two STB XTS 1100 screw-type connectors or STB XTS 2100 spring-type connectors (6-channel)				
STB XBA 1000		STB XBA 2000		STB XBA 1000
~ 24 V				
STB PDT 3100/3105				
~ 1780 V for 1 minute	~ 1500 V for 1 minute	~ 1780 V for 1 minute		~ 1500 V for 1 minute
~ 30 V (when sensor voltage is separate from logic bus voltage)		~ 200 V		
–				
Yes, time-lag fuse on the PDM power distribution module				
–				Yes, time-lag fuse on the PDM power distribution module
No	Yes	No		No
No	Yes (2)			Yes (2)
Basic		Standard		
STB ACI 1225	STB ACI 1230	STB ACI 0320	STB ACI 8320	STB ART 0200

62

62

Advantys™ STB Distributed I/O Solution

Analog output modules

Applications

Analog output modules

Voltage



Number of channels	2		
Range	0...10 V	-10...+10 V	0...+ 10 V, - 10...+ 10 V
Resolution	10 bits	9 bits + sign	11 bits + sign or 12 bits
Load current/channel (outputs)	5 mA		
Response time	3 ms for both channels		
Acquisition period	-		
Acquisition or update time	25 ms for both channels		
Internal power supply of 3-wire actuators	Yes		
Connections	Two STB XTS 1100 screw-type connectors or STB XTS 2100 spring-type connectors (6-channel)		
Base	STB XBA 1000		
PDM power distribution modules (1)	Voltage	... 24 V	
	Catalog number	STB PDT 3100/3105	
Isolation	Field-to-bus	... 1500 V for 1 minute	
	Channel-to-channel	... 30 V (when actuator voltage is separate from logic bus voltage)	
COM fault fallback positions	0 V on 2 channels		(2)
Protection against	Reverse polarity	Yes	
	Short circuit and overload	2.5 A time-lag fuses recommended on each channel. To be supplied by the user	
	Electronic protection of sensor power supply	No	Yes
Range	Basic		Standard

Type of module	STB AVO 1255	STB AVO 1265	STB AVO 1250
-----------------------	---------------------	---------------------	---------------------

Page	62
-------------	----

(1) One PDM (Power Distribution Module) is required per voltage group.
 (2) Hold last value; reset to 0 V on both channels; go to a predefined value (between 0 V and full scale) on each channel.
 (3) By default, reset to zero on both channels. Each channel individually adjustable: hold the value, go to a predefined value between 0 and 100% of the output range.

Analog output modules

Current



2		
4...20 mA	0...20 mA	4...20 mA 0...20 mA
10 bits	12 bits	15 bits + sign
20 mA		
3 ms for both channels		4 ms for both channels
-		
25 ms for both channels		-
No		
Two STB XTS 1100 screw-type connectors or STB XTS 2100 spring-type connectors (6-channel)		
STB XBA 1000		STB XBA 2000
~ 24 V		
STB PDT 3100/3105		
~ 1500 V for 1 minute		~ 200 V
~ 30 V (when actuator voltage is separate from logic bus voltage)		-
4 mA on 2 channels	(2)	(3)
Yes		
Yes, time-lag fuse on the PDM power distribution module		
No		
Basic	Standard	
STB ACO 1225	STB ACO 1210	STB ACO 0220

Presentation

The STB analog inputs allow the acquisition of various analog values encountered in industrial applications. The STB analog outputs are used to control analog field devices such as variable speed drives, proportional control valves, etc.

The range of basic analog I/O modules comprises:

- 3 analog input modules:
 - 2 analog voltage input channels 0...10 V,
 - 2 analog current input channels ± 10 V,
 - 2 analog current input channels 4...20 mA.
- 3 analog output modules:
 - 2 analog channels, current output 0...10 V,
 - 2 analog channels, current output ± 10 V,
 - 2 analog channels, voltage output 4...20 mA.

The range of standard analog I/O modules comprises:

- 5 analog input modules:
 - 2 analog voltage input channels ± 10 V,
 - 2 analog current input channels 0...20 mA,
 - 2 channels for thermocouple, temperature probe or voltage (mV),
 - 4 analog input channels 15 bits + sign, current 4...20 mA and 0...20 mA,
 - 4 analog input channels 15 bits + sign, current 4...20 mA and 0...20 mA, HART tolerant.
- 3 analog output modules:
 - 2 analog channels, current output 0...10 V or ± 10 V,
 - 2 analog channels, current output 0...20 mA,
 - 2 analog channels, output current 4...20 mA and 0...20 mA, 15 bits + sign.

Description

The front panel of a typical analog input/output module features:

- 1 A place for a customized label.
- 2 A display showing the state of the module (RDY, ERR).

Indication	Basic analog I/O modules	Standard analog I/O modules
Module status (1)	Green RDY LED	Green RDY LED
Module error (2)	–	Red ERR LED

- 3 A color-coded module identification stripe.
- 4 Two receptacles for screw or spring-type removable connectors.

To be ordered separately:

- An STB XBA 1000 mounting base, width 13.9 mm (0.54").
- Removable connectors (6 contacts), screw-type STB XTS 1100 or spring-type STB XTS 2100.
- Grounding of cable shielding is mandatory. The optional grounding kit STB XSP 3000 can also be used to secure cables in installations subject to severe vibration.
- 5 Optional grounding kit STB XSP 3000.
- 6 Connectors STB XSP 3010 for cables with cross-section 1.5...6 mm² (0.06 ... 0.23" ²) or STB XSP 3020 for cables with cross-section 5...11 mm² (1.19...0.43" ²).

Optional mechanical keying pins:

- between I/O module and I/O base: STB XMP 7700,
 - between wiring connectors and I/O module: STB XMP 7800.
- These devices ensure that the I/O modules, their bases and the wiring connectors are properly matched after dismantling or replacement.
- Sheets of customizing labels: STB XMP 7600.

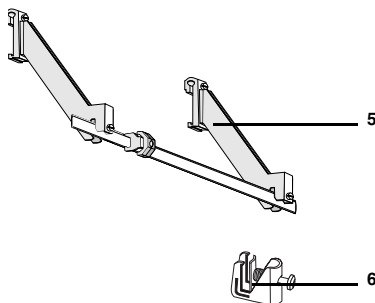
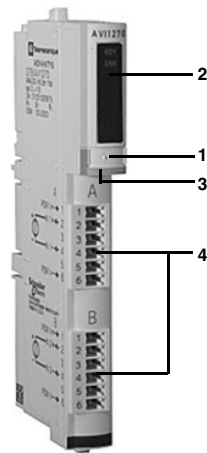

(1) RDY LED lit: module OK. RDY LED off: no power from PDM. RDY LED flashing: fault.
 (2) ERR LED lit: internal error ERR LED off: module OK. ERR LED flashing: module error.
 Consult the "System hardware components reference guide" included on the CD-ROM STB SUS 8800 or available from our website www.us.telemecanique.com.

Characteristics of analog input modules				
Type of module	STB	AVI 1255	AVI 1270	AVI 1275
Type		Basic	Standard	Basic
Number of channels		2		
Range		0...10 V	± 10 V	
Resolution	bits	10	11 + sign	9 + sign
Maximum input		∓ 50 V		
Response time	ms	5 for both channels		
Swapping	Cold swap	Yes		
	Hot swap	Yes, depending on NIM and mandatory nature of module. See table on page 41		
Data format		Complies with IEC/EN 61131-2		
Update time	ms	10 for 2 channels		
Input filter		Single low-pass filter with cut-off frequency of 25 Hz		
Integral linearity	% of full scale	± 0,2		
Differential linearity		Monotonic		
Input impedance	Ω	400 K		
Current supplied to sensors, per channel	mA	100		
Electronic short-circuit protection		No	Yes	No
Source impedance	kΩ	1 max.		
Absolute accuracy		± 0.5% of full scale at 25°C (77°F)		± 0.75% of full scale at 25°C (77°F)
Temperature drift		± 0.01% of full scale per degree C		
Isolation	Between channels and logic bus	V	∓ 1500 for 1 minute	
	Between channels and sensor bus	V	∓ 30 (when sensor bus power supply separate from sensor power supply)	
Addressing		2 words (1 data word per channel)	4 words (2 words per channel)	2 words (1 data word per channel)
I/O base		STB XBA 1000		
PDM power distribution module	Voltage	V	∓ 24	
	Model		STB PDT 3100/3105	
Logic bus current consumption at ∓ 5 V	mA	60		

(1) Basic NIM modules do not support hot swapping of input/output modules.

Characteristics of analog input modules (continued)							
Type of module	STB	ACI 1225	ACI 1230	ACI 0320	ACI 8320	ART 0200	
Type		Basic	Standard	Standard	Standard	Standard	
Number of channels		2		4		2 multi ranges in any configuration	
Range		4...20 mA	0...20 mA (1)	4...20 mA and 0...20 mA		Pt 100, Pt 1000, Ni 100, Ni 1000 and Cu 10 2, 3 or 4-wire temperature probes B, E, J, K, R, S, T thermocouples Voltage ± 80 mV	
Resolution	bits	10	12	15 + sign			
Maximum input		25 mA at --- 50 V				--- ± 7.5 V	
Response time	ms	5 for both channels		–		See page 59 for details	
Swapping	Cold swap	Yes					
	Hot swap	Yes, depending on NIM and mandatory nature of module. See table on page 41					
Data format		Complies with IEC/EN 61131-2					
Update time	ms	10 for 2 channels		10 for 4 channels	80 for 4 channels	See page 59 for details	
Cut-off frequency of low-pass input filter	Hz	25		985		25	
Integral linearity	% of full scale	± 0.2	± 0.1	± 0.05		See page 59 for details	
Differential linearity		Monotonic		–			
Input impedance	Ω	≤ 300		250		–	
Current supplied to sensors, per channel	mA	100		25		100	
Electronic short-circuit protection		No	Yes				
Source impedance	kΩ	–					
Absolute accuracy		± 0.5% of full scale at 25 °C (77°F)		± 0.4% at 25 °C (77°F)		See page 59 for details	
Temperature drift		± 0.01% of full scale per °C		± 0.005% per °C		See page 59 for details	
Isolation	Between channels and logic bus	V		--- 1500 for 1 minute		~ 1780 for 1 minute	
	Between channels and sensor bus	V		--- 30 (3)		--- 200	
Addressing		2 words (1 word per channel)	4 words (2 words per channel)	8 words (2 words per channel)		2 words (2 words per channel + 1 for cold-junction compensation)	
I/O base		STB XBA 1000		STB XBA 2000		STB XBA 1000	
PDM power distribution module	Voltage	V					--- 24
	Model						STB PDT 3100/3105
Logic bus current consumption at --- 5 V	mA	60		250		55	

(1) If the STB ACI 1230 module is configured with the STB SPU 1000 software, a zero offset can be set, e.g. 4...20 mA.

(2) Basic NIM modules do not support hot swapping of input/output modules.

(3) Sensor bus power supply separate from sensor power supply.

Advantys™ STB Distributed I/O Solution

Analog input modules

Detailed characteristics of STB ART 0200 analog input module				B	E	J	K	R	S	T	
Thermocouple range				°C or °F (°C by default)							
Temperature unit				°C or °F (°C by default)							
Nominal values		°C (°F)	130 to 1,820 °C (266 to 3,308 °F)	- 270 to + 1,000 °C (- 518 to + 1,832 °F)	- 200 to + 760 °C (- 392 to + 1,400 °F)	- 270 to + 1,370 °C (- 518 to + 2,498 °F)	- 50 to + 1,665 °C (- 122 to + 3,029 °F)	- 50 to + 1,665 °C (- 122 to + 3,029 °F)	- 270 to + 400 °C (- 518 to + 752 °F)		
Resolution			0.1°C or °F								
Broken wire detection			Monitored independently on each channel								
Conversion time	With internal cold-junction compensation	ms	230 at 50 Hz 210 at 60 Hz								
	With external cold-junction compensation	ms	400 at 50 Hz 360 at 60 Hz								
Accuracy (thermocouple errors not included)	With internal cold-junction compensation	at 25°C (77°F)	°C (°F)	± 4.6 (40.28)	± 4.6 (40.28)	± 5.1 (41.18)	± 4 (39.2)	± 3.6 (38.48)	± 4.1 (39.38)	± 4.4 (39.92)	
		at 60°C (140°F)	°C (°F)	± 6.8 (44.24)	± 6.8 (44.24)	± 7.0 (44.6)	± 5.5 (41.9)	± 4.2 (39.56)	± 5.0 (41)	± 6.4 (43.52)	
	With external cold-junction compensation	at 25°C (77°F)	°C (°F)	± 1.75 (35.15)							
		at 60°C (140°F)	°C (°F)	± 2.85 (37.13)							
Temperature probe			Pt 100	Pt 1000	Ni 100	Ni 1000	Cu 10				
Type			2, 3 or 4-wire (3-wire by default)								
Temperature unit			°C or °F (°C by default)								
Nominal values	IEC	°C (°F)	-200 to +850 (by default) (-392 to +1,562)				-60 to +180 (-140 to +356)		-100 to +260 (-212 to +500)		
	US/JIS	°C (°F)	-100 to +450 (-212 to +842)				-				
Resolution			0.1 °C or °F								
Broken wire detection			Monitored independently on each channel								
Max. wiring resistance	4-wire	Ω	50 (IEC/US/JIS)		500 (IEC/US/JIS)		50	500	50		
	2 or 3-wire	Ω	20 (IEC/US/JIS)		200 (IEC/US/JIS)		20	200	20		
Conversion time	3-wire	ms	340 at 50 Hz 300 at 60 Hz								
	2 or 4-wire	ms	200 at 50 Hz 180 at 60 Hz								
Accuracy (temperature probe errors not included)	25°C (77°F) internal	°C (°F)	± 1 (33.8)				± 1 (33.8)		± 4 (39.2)		
	25°C (77°F) external	°C (°F)	± 2 (35.6)				± 1 (33.8)		± 4 (39.2)		
Voltage											
Range		mV	± 80 (± 81.92)								
Resolution			Increments of 0.01 mV								
Conversion time		ms	170 at 50 Hz 150 at 60 Hz								
Input impedance		MΩ	10 (standard)								
Accuracy	25°C (77°F) internal	% of full scale	± 0,1								
	25°C (77°F) external	% of full scale	± 0.15 at ambient temperature								

Characteristics of analog output modules				
Type of module		STB AVO 1255	STB AVO 1265	STB AVO 1250
Type		Basic		Standard
Number of channels		2		
Range		0... 10 V	± 10 V	0... 10 V ± 10 V
Resolution	bits	10	9 + sign	12 11 + sign
Output current per channel	mA	5		up to 5
Response time	ms	3		
Swapping	Cold swap	Yes		
	Hot swap	Yes, depending on NIM and mandatory nature of module. See table on page 41		
Data format		Complies with IEC/EN 61131-2		
Update time	ms	25 for 2 channels		
Conversion time	µs	–		
Short circuit protection on the outputs		Yes		
Integral linearity		± 0.1% of full scale, typical		
Differential linearity		Monotonic		
Absolute accuracy		± 0.5% of full scale at 25°C (77°F)		
Temperature drift		± 0.01% of full scale per °C		
Isolation	Between channels and logic bus	V	∞ 1500 for 1 minute	
	Between channels and actuator bus	V	∞ 30 (when actuator bus power supply separate from actuator power supply)	
Fallback states	Default	V	0 V on 2 channels	
	User-configurable setting (1)		–	Hold last value, allocate a predefined value
Fallback mode			Predefined	User configurable
Addressing			2 output data words	2 output data words and 2 non-adjacent input bytes (module and channel status diagnosis)
I/O base			STB XBA 1000	
PDM power distribution module	Voltage	V	∞ 24	
	Model		STB PDT 3100/3105	
Logic bus current consumption at ∞ 5 V	mA	80		

(1) Requires Advantys configuration software.

Characteristics of analog output modules				
Type of module		STB ACO 1225	STB ACO 1210	STB ACO 0220
Type		Basic	Standard	
Number of channels		2		
Range		4... 20 mA	0... 20 mA (1)	4... 20 mA and 0... 20 mA
Resolution		bits 10	12	15 + sign
Output current per channel		mA 20		
Response time		ms 3		–
Swapping	Cold swap	Yes		
	Hot swap	Yes, depending on NIM and mandatory nature of module. See table on page 41		
Data format		Complies with IEC/EN 61131-2		
Update time		ms 25 for 2 channels	–	
Conversion time		900 μs at ± 0.1% of final value		4 ms for both channels
Short circuit protection on the outputs		Yes		–
Integral linearity		± 0.1% of full scale, typical		± 0.5% of full scale, typical
Differential linearity		Monotonic		
Absolute accuracy		± 0.5% of full scale per °C		± 0.3% at 25°C (77°F)
Temperature drift		± 0.01% of full scale per °C		± 0.005% of full scale per °C
Isolation	Between channels and logic bus	V	∞ 1500 for 1 minute	
	Between channels and actuator bus	V	∞ 30 (2)	∞ 200
Fallback states	Default	V	4 mA on 2 channels	Minimum output (0 mA)
	User-configurable setting (3)		–	Hold last value, allocate a predefined value
Fallback mode			Predefined	User configurable
Addressing			2 output data words	2 output data words plus 1 for configuring fallback state
I/O base			STB XBA 1000	STB XBA 2000
PDM power distribution module	Voltage	V	∞ 24	
	Model		STB PDT 3100/3105	
Logic bus current consumption at ∞ 5 V		mA	80	
				≤ 250

(1) If the STB ACI 1230 module is configured with the STB SPU 1000 software, a zero offset can be set, e.g. 4...20 mA.

(2) Actuator bus power supply separate from actuator power supply.

(3) Requires Advantys configuration software.

Advantys™ STB Distributed I/O Solution

Analog input/output modules



STB AVI 1270



STB AVO 1250

Catalog numbers

Standard analog input modules

Input signal	Number of channels	Resolution (bits)	Catalog number	Weight kg
±10 V	2	11 + sign	STBAVI1270	0.115
0...20 mA	2	12	STBACI1230	0.116
4...20 mA and 0...20 mA	4	15 + sign	STBACI0320	–
4...20 mA and 0...20 mA, HART 4	4	15 + sign	STBACI8320	–
Thermocouples ± 80 mV	2	15 + sign	STBART0200	–

Basic analog input modules

Input signal	Number of channels	Resolution (bits)	Catalog number	Weight kg
-10...+10 V	2	9 + sign	STBAVI1275	0.115
0...10 V	2	10	STBAVI1255	0.116
4...20mA	2	10	STBACI1225	–

Standard analog output modules

Output signal	Number of channels	Resolution (bits)	Catalog number	Weight kg
0... 10 V or ±10 V	2	12	STBAVO1250	0.116
0... 20 mA	2	12	STBACO1210	0.117
4...20 mA and 0...20 mA	2	15 + sign	STBACO0220	–

Basic analog output modules

Output signal	Number of channels	Resolution (bits)	Catalog number	Weight kg
-10...+10 V	2	9 + sign	STBAVO1265	0.115
0...10 V	2	10	STBAVO1255	0.116
4... 20mA	2	10	STBACO1225	–



STB XBA 1000

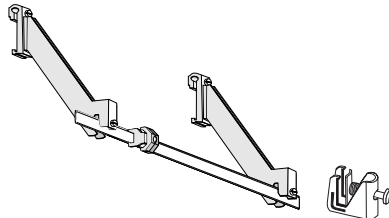

STB XSP 3000

STB XSP 3010/3020

Catalog numbers

Mandatory separate parts

Description	Base width	For I/O modules	Catalog number	Weight kg
I/O base	13.9 mm (0.54")	STB AVI STB ACI 1230/1225 STB ART STB AVO STB ACO	STBXBA1000	0.024
		18.4 mm (0.72") STB ACI 0320/8320	STBXBA2000	–

Description	Connection type	For I/O modules	Sold in lots of	Catalog number	Weight kg
Removable connectors (6 contacts) (1)	Screw-type	STB AVI STB ACI STB ART STB AVO STB ACO	20	STBXTS1100	0.006
	Spring-type	STB AVI STB ACI STB ART STB AVO STB ACO	20	STBXTS2100	0.006

Optional separate parts

Description	Use	Sold in lots of	Catalog number	Weight kg
Insulated screwdriver 2.5mm(0.10")	Screw-type removable connectors	–	STBXTT0220	–
Grounding kit	Grounding for shielded cables Composed of 1 bar (length 1 m / 1.09 yd) and 2 lateral supports	–	STBXSP3000	–
Terminals for grounding kit	Cables with cross-section 1.5...6 mm ² (0.06...0.23" ²)	10	STBXSP3010	–
	Cables width 5...11 mm ² (0.19 ...0.43" ²)	10	STBXSP3020	–
Keying pins	For modules	60	STBXMP7700	–
	For removable connectors	96	STBXMP7800	–
Customizing labels (2)	I/O bases and modules	25 sheets	STBXMP6700	–

(1) All connectors can accommodate a flexible wire with maximum cross-section of 1.5 mm² (0.06" ²), including cable end piece. For screw connectors, the maximum tightening torque is 0.25 Nm (2.21 lb-in).

(2) A template for producing customized labels is supplied on the documentation mini-CD-ROM.

Connections

Analog input modules

STB AVI 1255/1270/1275

2 isolated analog sensors, external 24 V power supply

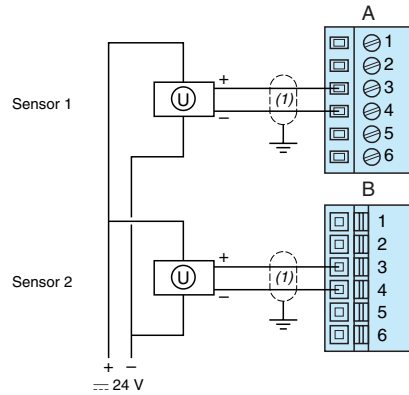

2 analog sensors, 24 V supplied by PDM

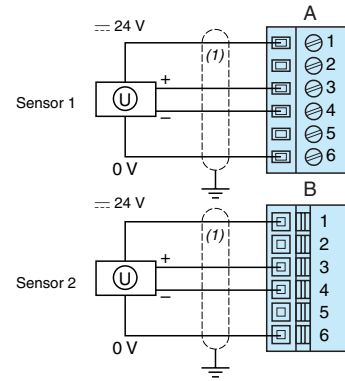

STB ACI 1225/1230

2 isolated analog sensors, external 24 V power supply

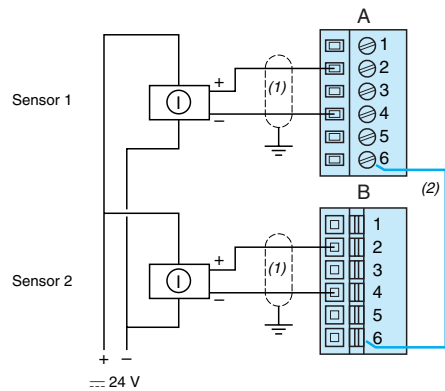

2 analog sensors, 24 V supplied by PDM

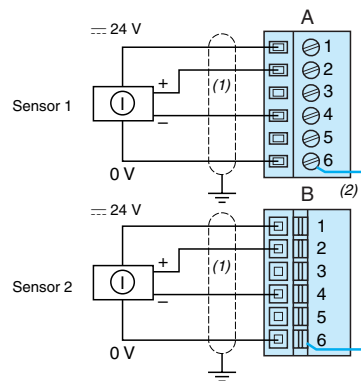

2 analog sensors requiring a supply loop

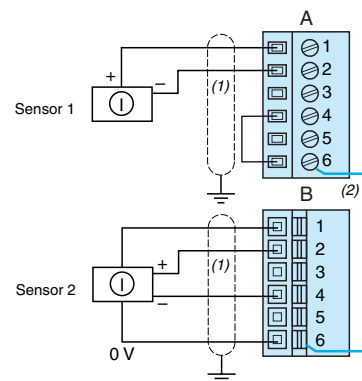

STB ACI 0320/8320

4 isolated analog sensors, external 24 V power supply

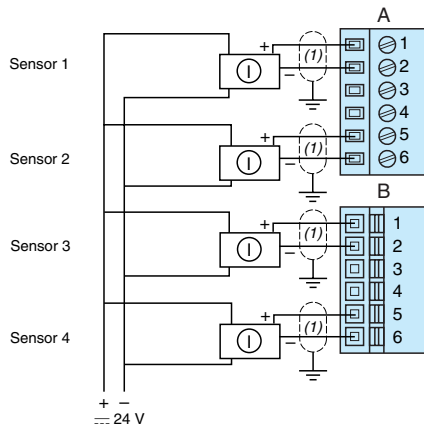

(1) STB XSP 3000 grounding kit with STB XSP 3010/3020 connector mandatory.
 (2) Internal connection.



Connections (continued)

Analog input modules

STB ART 0200

2 and 3-wire temperature probes

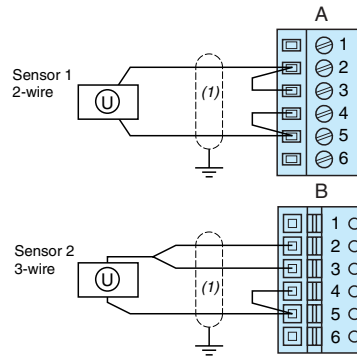

2-wire temperature probes for highly disturbed operating environments

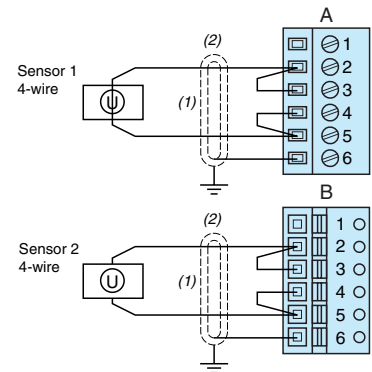

2-wire thermocouple and voltage sensor (mV)

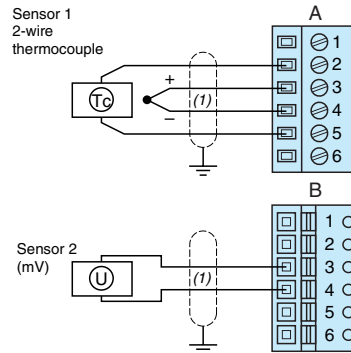

4-wire temperature probes

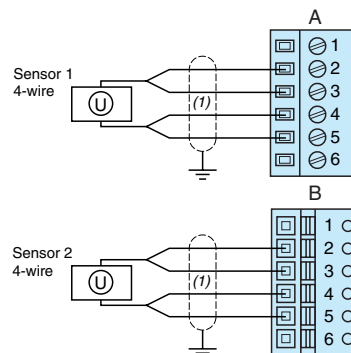

(1) STB XSP 3000 grounding kit with STB XSP 3010/3020 connector mandatory.
 (2) Double-shielded cable.

Connections (continued)

Analog output modules

STB AVO 1255/1265/1250

2 isolated analog actuators

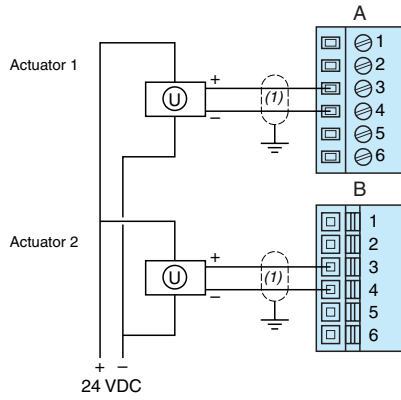

2 analog actuators, 24 V supplied by PDM

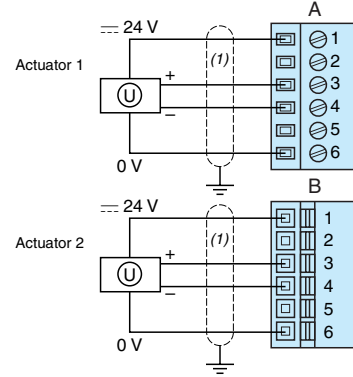

STB ACO 1225/1210

2 isolated analog actuators

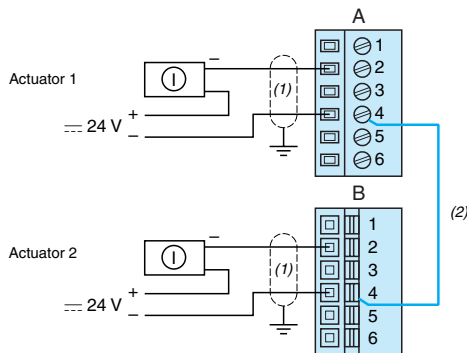

2 analog actuators, 24 V supplied by PDM

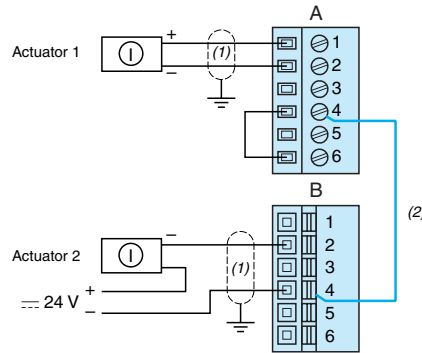

(1) STB XSP 3000 grounding kit with STB XSP 3010/3020 connector mandatory.
 (2) Internal connection.

Connections (continued)

Analog output modules

STB ACO 0220

2 isolated analog sensors, external 24 V power supply

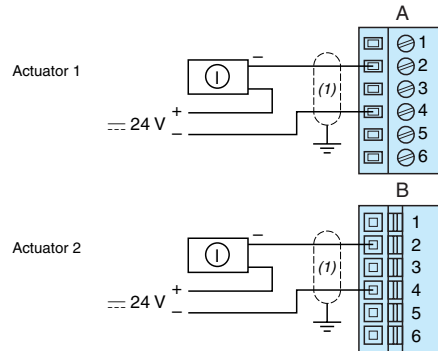

2 analog actuators, 24 V supplied by PDM

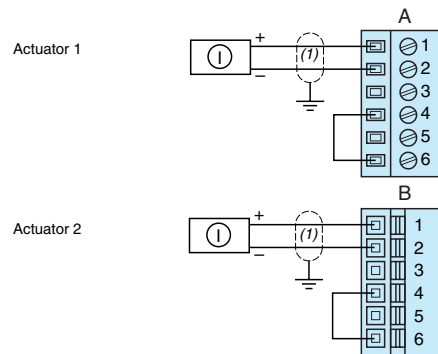

2 analog actuators, 24 V supplied by PDM

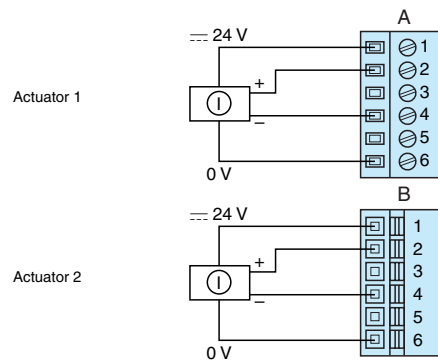

(1) STB XSP 3000 grounding kit with STB XSP 3010/3020 connector mandatory.



Advantys™ STB Distributed I/O Solution

Parallel interface module STB EPI 2145
TeSys® Model U and TeSys® Quickfit Applications

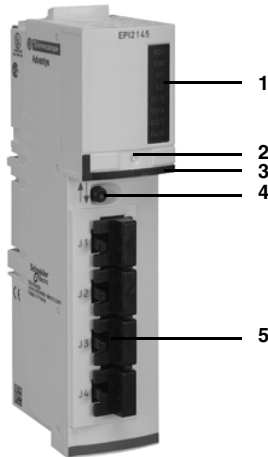

Description

The application-specific, parallel interface module STB EPI 2145 is a component of the Advantys STB island designed for the remote connection of TeSys Model U starter-controllers and TeSys Quickfit prewired motor-starters.

The application-specific STB EPI 2145 parallel interface comprises:

- 1 A display block with LEDs for the various states of the starter-controllers or TeSys Quickfit prewired motor-starters.

Indication	Standard STB EPI 2145 module
Module status (1)	Green RDY LED
Module error (2)	Red ERR LED
Switch position 4 (3)	Green S1 and S2 LEDs
State of outputs	Green LEDs O1/5, O2/6, O3/7, O4/8

- 2 A location for a customizing label.
 3 A color-coded module identification stripe (black).
 4 A selection switch used to view each motor-starter state.
 5 4 RJ45 connectors for connection of:
- 4 TeSys Model U starter-controllers.
 - 4 direct motor-starters with TeSys Quickfit components.
 - 2 reversing motor-starters with TeSys Quickfit components.
- i.e. 12 inputs and 8 outputs in each of these configurations.

To be ordered separately:

- STB XBA 3000 base width 28.1 mm (1.10"). Includes a place for customizing labels.
- Optional mechanical keying pins between module and base of I/O: STB XMP 7700. This device ensures that the module and its base are properly matched after dismantling or replacement.
- Sheets of customizing labels: STB XMP 7600.
- RJ45 cables between module STB EPI 2145 and each TeSys Model U.

(1) RDY is on permanently if the module is operational. If RDY is not lit, the PDM is not supplying power. If RDY flashes, the module is faulty.

(2) If ERR is lit or flashing, the module has an internal error.

For information about the signaling of module and channel states, consult the "System hardware components reference guide" included on the CD-ROM STB SUS 8800 or available from our website www.us.telemecanique.com.

(3) S1: output bank 1 (outputs 1 to 4).

S2: output bank 2 (outputs 5 to 8).

Advantys™ STB Distributed I/O Solution

Parallel interface module STB EPI 2145
TeSys® Model U and TeSys® Quickfit Applications

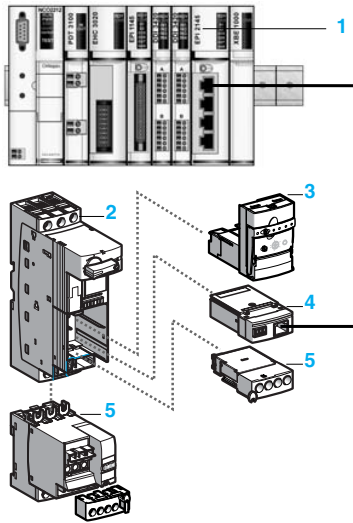

TeSys Model U starter control application

Presentation of the TeSys Model U starter-controller

The TeSys Model U starter-controller is a direct motor-starter which performs the following functions:

- Protects and controls single phase or 3-phase motors:
 - disconnects power,
 - protects against overcurrent and short-circuit,
 - protects against thermal overload,
 - performs power switching.
- Application control:
 - protection alarms, application monitoring: duration of use, number of faults, motor current values etc.
 - history.

Composition of a TeSys Model U starter with module STB EPI 2145 (1)

The starter-controller functions are performed by a click-lock adjustment that removes the need for cables,

- on a power base **2** (LU2B + LU9 BN11),
- a --- 24 V **3** control unit (LUC B/D/C/M ●●BL) for 0.09 to 15 kW motors,
- a parallel communication module (LUF C00) **4**,
- options (additional contacts, inverter blocks) **5** including LU9 M1●.

Each of the 4 channels of the STB EPI 2145 application-specific module combined with a TeSys Model U starter has the following features:

- 2 outputs.
 - starter control.
 - reversal control.
- 3 inputs.
 - state of circuit-breaker (position of lever).
 - presence of fault (short-circuit, thermal).
 - state of main contactor (closed/open).

(1) TeSys Model U components: consult our catalog "Starters and basic TeSys Model U equipment".

Advantys™ STB Distributed I/O Solution

TeSys® Quickfit for motor-starter components

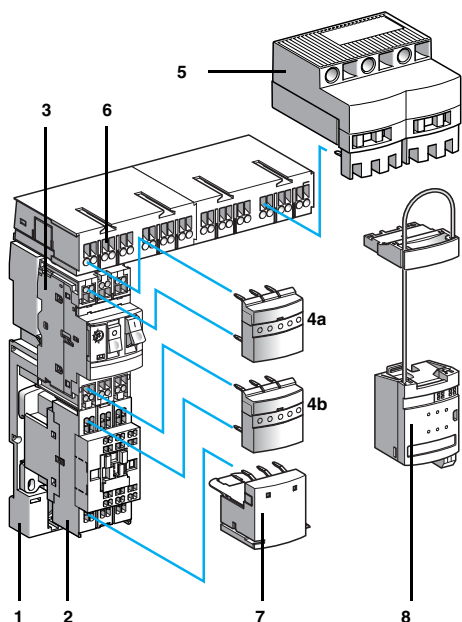

TeSys Quickfit components for motor-starters

TeSys Quickfit is a modular system which standardizes and simplifies the installation of motor-starters. Combined with circuit-breakers GV2 ME and TeSys® Model D contactors (LC1) from 9 to 25 A, TeSys Quickfit facilitates the installation of motor-starters with spring-type terminal up to 11 kW/400V.

TeSys Quickfit offers prewiring elements:

- power circuits
- control circuits

Installation of a motor-starter become quick, easy, reliable and open-ended.

TeSys Quickfit also:

- allows later customization of the motor-starter,
- reduces maintenance time and
- saves space inside the equipment by reducing the number of terminals, channels and intermediate interfaces.

Elements for the prewiring of the power section

The TeSys Quickfit components for the prewiring of the power section are:

- a power kit comprising, for each output, a mounting plate **1** for the contactor **2** and circuit-breaker **3** and two power connection modules, **4a** and **4b**.
- a power splitter **5** for 2 or 4 outputs,
- an upstream terminal block **6** for connecting a power supply up to 60 A (16 mm² [0.63" ²] / # 5 AWG),
- a downstream terminal block **7** for connection of motor power supply cables and ground cables (6 mm² [0.23" ²] / # 10 AWG).

Elements for the prewiring of the control section

For the prewiring of the control section, the TeSys Quickfit systems offers a control connection module **8 LAD 9 AP3●●** which allows you to connect the motor outputs to the processing unit (PLC) via the parallel interface module **9 Advantys STB EPI 2145**, quickly and without tools.

The control connection module **LAD 9 AP3●●** is mounted directly on the contactor and the circuit-breaker of each motor-starter. It integrates the status and control information of this motor-starter.

A mechanical locking device **2** for the system on the head of the contactor guarantees a satisfactory connection whatever the conditions of use (vibration, shock etc.). 4 versions are available: for direct or reversing start, with or without contactor coil interface relay.

The module **LAD9 AP3●●** has several external connectors in its lower part including an RJ45 socket for connection to the Advantys **STB EPI 2145** parallel interface module via **LU9R●●** RJ45 cables **10**, available in different lengths.

The following information is available for each motor-starter:

- 2 inputs: status of circuit-breaker and status of contactor,
- 1 output: contactor coil control.

A direct motor-starter uses 1 RJ45 channel.

A reversing motor-starter uses 2 RJ45 channels.

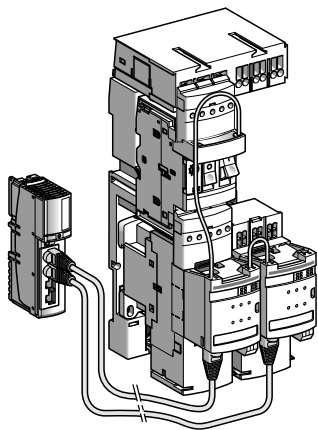

(1) See our catalog "motor-starter solutions. Motor control and protection components".

Advantys™ STB Distributed I/O Solution

Parallel interface module STB EPI 2145
TeSys® Model U and TeSys® Quickfit Applications

Characteristics			
Type of module		STB EPI 2145	
Cold swapping		Yes	
Hot swapping		Yes, depending on NIM and mandatory nature of module. See table on page 41	
Connection		Via 4 RJ45 connectors	
Power supply		Via STB PDT 3100/3105 24 V power distribution module	
Protection		Via STB PDT 3100/3105 power distribution module fuse	
Consumption	On 5 V logic bus	mA	up to 110
	On 24 V sensor bus	mA	up to 100
	On 24 V actuator bus	mA	at least 50 (with all 8 outputs at state 0), 80 mA per output at state 1 (up to 220 mA for 150 ms)
Input characteristics			
Number		12	
Nominal values	Voltage	24 V	24
Limit values	At state 1	Voltage	V 15...30
		Current	mA at least 2
	At state 0	Voltage	V - 3...+ 5
		Current	mA up to 0.5
Protection		Resistor-limited	
Output characteristics			
Number		8	
Rated voltage		24 V	24
Starter-controller compatibility		TeSys Model U 12 A (LUB 12 base) and 32 A (LUB 32 base). TeSys bases can be fitted with one of the following 24 V control units: - standard LUCA●●BL. - advanced LUCB●●BL, LUCC●●BL and LUCD●●BL. - multifunction LUCA●●BL.	
Motor-starter compatibility		With TeSys Quickfit prewiring components, components with spring-type terminals. Systems for motor-starters, from 0 to 25 A, up to 11 kW/400 V. The motor-starters concerned are those realized by combining: - GV2 ME circuit-breakers, with use limit at 80% of maximum current at ambient temperature of 60°C (140°F), up to 690 V standard LUCA●●BL. - with contactors TeSys® Model D (LC1) from 9 to 25 A. - with TeSys Quickfit LAD9 AP3●● control connection module and LU9R●● cables.	
Short circuit and overload protection		Yes, per channel	

Advantys™ STB Distributed I/O Solution

Parallel interface module STB EPI 2145
TeSys® Model U and TeSys® Quickfit Applications

Catalog numbers



STB XBA 3000



STB EPI 2145

TeSys Model U starter-controller module

Type of power supply	Voltage	Catalog number	Weight kg
---	24 V	STBEPI2145	0.165

Mandatory separate parts

Designation	Use	Length	Catalog number	Weight kg
Base 28.1 mm(1.10")	Application-specific module mounted on DIN rail	–	STBXBA3000	0.048
Connection cables An RJ45 connector at each end	Linking the STB EPI 2145 module to the starter-controller TeSys Model U (2) and TeSys Quickfit (3)	0.3 m (0.98 ft)	LU9R03	0.045
		1 m (3.28 ft)	LU9R10	0.065
		2 m (6.56 ft)	490NTW00002	–
		3 m (9.84 ft)	LU9R30	0.125
		5 m (16.4 ft)	490NTW00005	–
		12 m (39.3 ft)	490NTW00012	–

Optional separate parts

Designation	Use	Sold in lots of	Catalog number	Weight kg
Keying pin	For application-specific module	60	STBXMP7700	–
Sheets of customizing labels (1)	I/O bases and modules	25	STBXMP6700	–

(1) A template for producing customized labels is supplied on the documentation mini-CD-ROM.

(2) TeSys Model U forward only and forward/reverse requires only 1 cable.

(3) TeSys Quickfit forward only requires 1 cable, TeSys Quickfit forward/reverse requires 2 cables.

TeSys® Model U starter-controllers: Remote control

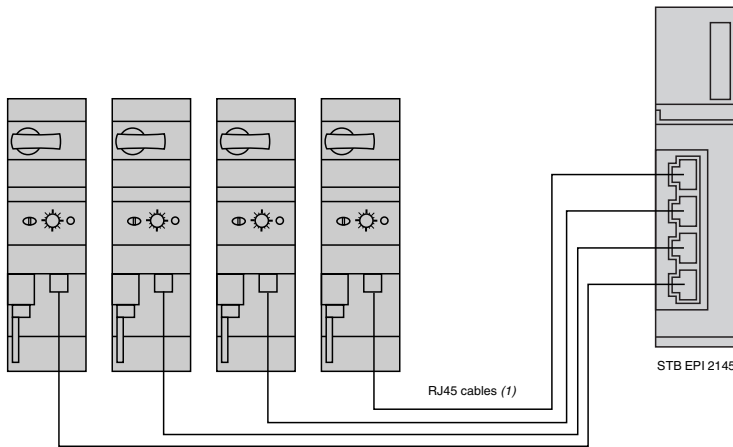

Simple connection of a parallel interface module STB EPI 2145 to 4 TeSys Model U starter-controllers for remote control via PLC.

- For each TeSys Model U starter-controller:
- LU 9BN11 or LU 9BM1: Supplied with TeSys Model U base.
 - LUF C00, parallel communication module: to be ordered separately.
 - 1 RJ45 cable. (1)

(1) Cables: see catalog numbers on page 72.

TeSys® Model U local and remote control

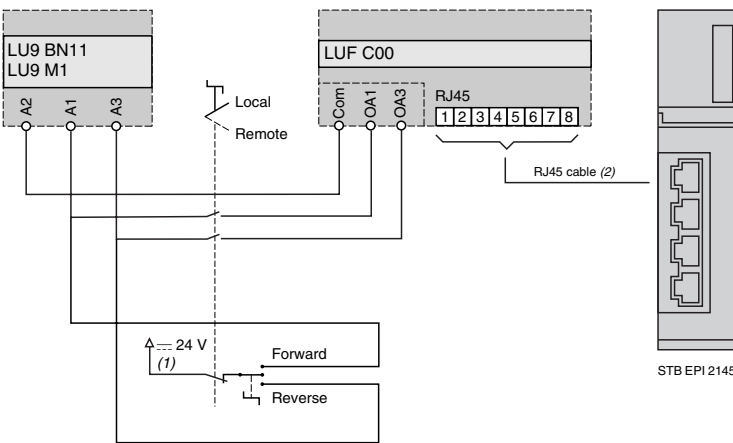

Schematic diagram of simple switching between remote control via Advantys STB EPI 2145 and local control by operator: diagram for a TeSys Model U starter-controller.

The reference 0 V is supplied by the parallel interface module STB EPI 2145 via cable to LUF C00. (1)

(1) 24 V power supply of the Advantys STB automation island common to the power distribution STB PDT 310.
(2) Cables: see catalog numbers on page 72.

TeSys® Model U local control, remote control, maintenance

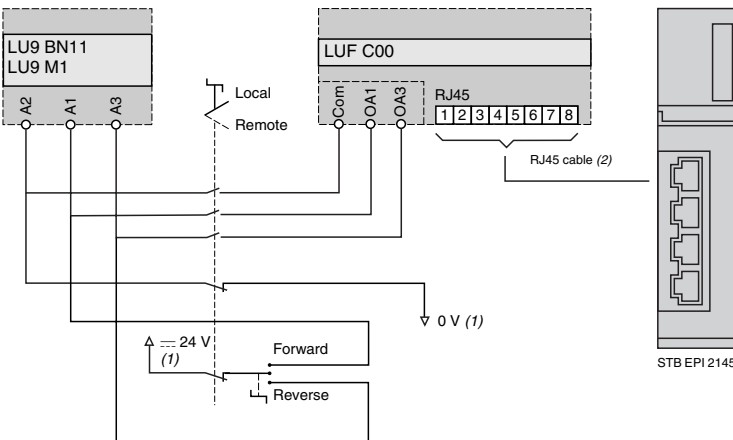

Schematic diagram of switching between remote control via Advantys STB EPI 2145 and local control by operator: diagram for a TeSys U starter-controller.

The 24 V power supply is local to the TeSys Model U starter-controller. (1)

In the absence of remote control or if the Advantys STB automation island is switched off or disconnected, the operator can control the running of the motor.

(1) 24 V power supply local to the TeSys Model U starter-controller and common to the power distribution module STB PDT 310.
(2) Cables: see catalog numbers on page 72.

Advantys™ STB Distributed I/O Solution

Parallel interface module STB EPI 1145
Tego® Power applications

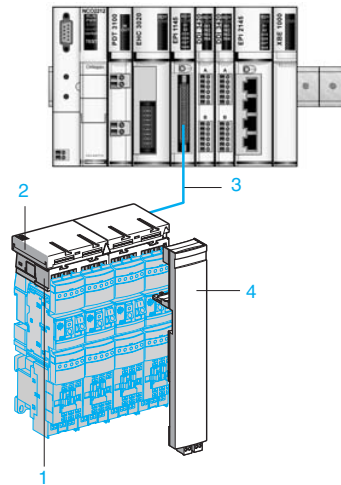

- 1 63 A power splitter box.
- 2 Control splitter box.
- 3 Connection cable.
- 4 Connection control module.

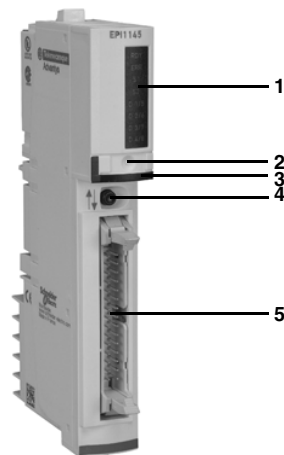

Presentation

The STB EPI 1145 parallel interface is a component of the Advantys STB island designed for the remote connection of 8 motor-starters (or 4 motor-starters in both directions). These TeSys® Model D motor-starters use the Tego Power installation assistance system.

The Tego Power System

Tego Power is a modular system to help install TeSys® Model D motor-starters by offering prewired control and power circuits. This Quickfit technology enables cable-free connections to spring-loaded terminals for TeSys® Model D contactors (9 to 25 A) and GV2 M2 motor circuit-breakers.

Tego Power with Quickfit technology enables you to create motor-starter assemblies up to 15 kW/400 V.

Structure of the Tego Power system

The Tego Power system differentiates the power section from the control section:

■ The power kit comprises:

- a specific plate used to assemble 2 to 8 motor-starters.
- two connection modules.
- a power splitter box with a power terminal block.

The contactor for each motor-starter is activated by one of the 8 outputs of the STB EPI 1145 parallel interface.

■ The control kit comprises:

- a control splitter box for the 2 to 8 motor-starters.
- a connection module.

The 2 return outputs of each motor-starter (contactor status, circuit-breaker status) are connected to 2 of the 16 inputs to the STB EPI 1145 parallel interface.

Description

The STB EPI 1145 parallel interface comprises:

- 1 A display block with 8 LEDs indicating the state of the various motor-starters or output devices.

Indication	Standard STB EPI 1145 module
Module status (1)	Green RDY LED
Module error (2)	Red ERR LED
Switch position 4 (3)	Green S1 and S2 LEDs
State of outputs	Green LEDs O1/5, O2/6, O3/7, O4/8

- 2 A location for a customizing label.
- 3 A color-coded module identification stripe (black).
- 4 A selection switch used to view each motor-starter state.
- 5 An HE 10 connector (30-pin) to connect to a Tego Power system via STB XCA 3002/3003 cables, length 1 m/2 m (1.09/2.18 yd).

To be ordered separately:

- STB XBA 2000 base width 18.4 mm (0.06"). Includes a location for a customizing label.
- Optional mechanical keying pin between module and base STB XMP 7700. This device ensures that the module and its base are properly matched after dismantling or replacement.
- Sheets of customizing labels: STB XMP 7600.
- A cable between module STB EPI 1145 and the Tego Power block

(1) RDY is on permanently if the module is operational. If RDY is not lit, the PDM is not supplying power. If RDY flashes, the module is faulty.

(2) If ERR is lit or flashing, the module has an internal error.

For information about the signaling of module and channel states, consult the "System hardware components reference guide" included on the CD-ROM STB SUS 8800 or available from our website www.us.telemecanique.com.

(3) S1: output bank 1 (outputs 1 to 4).

S2: output bank 2 (outputs 5 to 8).

Characteristics					
Electrical characteristics					
Type of module		STB EPI 1145			
Swapping	Cold swap			Yes	
	Hot swap			Yes, depending on NIM and obligatory nature of module. See table on page 41	
Connection		Via 1 HE 10 connector (30 contacts)			
Power supply		Via STB PDT 3100/3105 --- 24 V power distribution module			
Protection		Via STB PDT 3100/3105 power distribution module fuse			
Consumption	On --- 5 V logic bus	mA		up to 110	
	On --- 24 V sensor bus	mA		up to 100	
	On --- 24 V actuator bus	mA		at least 50 (with all 8 outputs at state 0), up to 1,000 (with all 8 outputs at state 1)	
Input characteristics					
Number		16 (8 for the status of each contactor/8 for the status of each circuit-breaker)			
Nominal values	Voltage	--- V		24	
Limit values	At state 1	Voltage	V	15...30	
		Current	mA	at least 2	
	At state 0	Voltage	V		- 3...+ 5
		Current	mA		up to 0.5
Protection		Resistor-limited			
Output characteristics					
Number		8 (8 to control each contactor)			
Nominal values	Voltage	--- V		24	
	Current	mA		100 per channel, 850 per module	
Limit values	Permanent voltage	V		19.2...30	
	Absolute voltage	V		36	
	Peak voltage	A		1 for 100 µs per channel	
Max. loads	Capacity	µF		50	
	Inductance			0.5 Henry at 4 Hz	
Short circuit and overload protection		Yes, per channel			

Catalog numbers



STB XBA 2000



STB EPI 1145

Parallel interface for TeSys® motor-starters with Tego Power system			
Type of power supply	Voltage	Catalog number	Weight kg
---	24 V	STBEPI1145	0.120

Obligatory separate parts				
Designation	Use	Length	Catalog number	Weight kg
Base 18.4 mm (0.72")	Application-specific module mounted on DIN rail	–	STBXBA2000	0.024
Connection cables (30-pin at each end)	From power and control splitter box APP 2R●E to module STB EPI 1145	1 m (1.09 yd)	STBXCA3002	–
		2 m (2.18 yd)	STBXCA3003	–

Obligatory separate Tego Power parts (2)			
Designation	Use	Catalog number	Weight kg
Power and control splitter boxes	2 outputs	APP2R2E	–
	4 outputs (3)	APP2R4E	–

Optional separate parts				
Designation	Use	Sold in lots of	Catalog number	Weight kg
Keying pin	For application-specific module	60	STBXMP7700	–
Sheets of customizing labels (1)	I/O bases and modules	25	STBXMP6700	–

(1) A template for the customizing labels is supplied with the documentation mini-CD-ROM.
(2) For other Tego Power components, refer to our catalog: "Motor-starter solutions, control and power protection components."
(3) For a set of 8 motor-starters, use 2 x APP 2R4E splitter boxes.

Presentation

Counting parts or events, grouping objects, controlling incoming and outgoing data streams, and measuring lengths or positions all require counting functions.

The STB EHC 3020 counter module performs these functions for an Advantys STB automation island (controlled by a master connected to the island) with a maximum counting frequency of 40 kHz.

The STB EHC 3020 module, with 1 counting channel, accepts as input typical \approx 24 V sensors: proximity sensors, photo-electric detectors, incremental encoders or mechanical contacts (1). As output, the module features 2 static \approx 24 V 0.5 A outputs.

The Advantys configuration software is used to select one of the six functions the module can perform.

Description

The front panel of the STB EHC 3020 counter module features:

- 1 A display block with 8 display LEDs:

Indication	Standard STB EHC 3020 module
Module status (2)	Green RDY LED
Module error (3)	Red FLT LED
State of the 2 outputs	Green OUT1 and OUT2 LEDs
State of the 2 counting inputs	Green INA and INB LEDs
State of Reset input	Green RST LED
State of EN validation input	Green EN LED

- 2 Place for customizing labels.
- 3 Color-coded module identification stripe (black).
- 4 A connector for an STB XTS 2150 18-pin removable spring-type connector (must be ordered separately).

To be ordered separately:

- STB XBA 3000 base width 28.1 mm (1.10"). Includes a place for customizing labels.
- 18-pin removable spring-type connector STB XTS 2150.
- It is advisable to use a grounding kit for connecting the cable shielding.
- 5 STB XSP 3000 grounding kit,
- 6 Connectors STB XSP 3010 for cables with cross-section 1.5...6 mm² (0.06...0.23" ²) or STB XSP 3020 for cables with cross-section 5...11 mm² (0.19...0.43" ²).
- Optional mechanical keying pin between module and base STB XMP 7700. This device ensures that the module and its base are properly matched after dismantling or replacement.
- Sheets of customizing labels: STB XMP 7600.

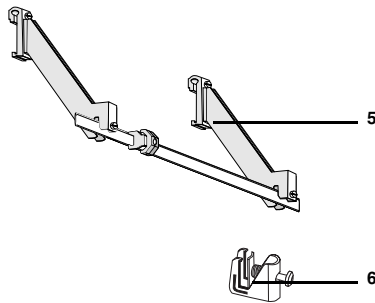
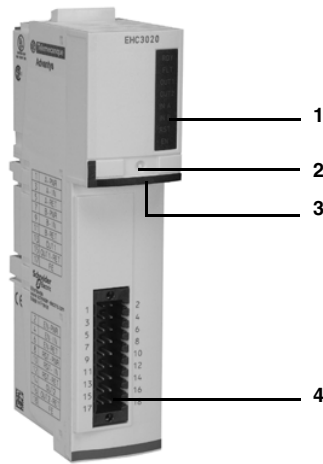

(1) The counting frequency is limited to 400 Hz with mechanical contacts.

(2) RDY is on permanently if the module is operational. If RDY is not lit, the PDM is not supplying power. If RDY flashes, the module is faulty.

(3) If FLT is lit or flashing, the module has an internal error.

For information about the signaling of module and channel states, consult the "System hardware components reference guide" included on the CD-ROM STB SUS 8800 or available from our website www.us.telemecanique.com.

Operation

Counter channel block diagram

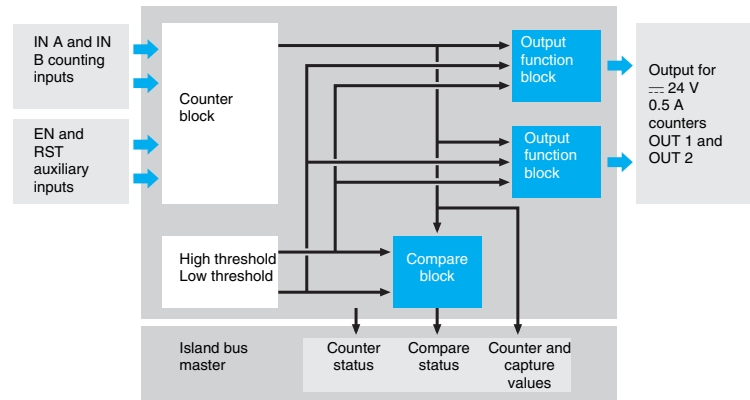

Depending on the counting function used (see functional characteristics page 78), the I/O for the STB EHC 3020 module are allocated to:

- Input IN A, connected to a sensor.
- Inputs IN B, EN and RST, connected to a sensor or activated by the Advantys STB master via the field bus.

The 16-bit counter value is compared with the two threshold values (configured with the configuration software) and is used to activate the two OUT 1 and OUT 2 outputs, without requiring processing by the bus master controller. Reports such as the counting value or the two status bits (counter status, compare status) are sent to the bus master controller.

Functional characteristics

Configurable functions	Number	1 of the 6 configurable functions (using the Advantys configuration software)
Frequency meter		This basic function measures the frequency received on the IN A input. This frequency is always expressed in Hz (number of pulses per second), with a precision of 1 Hz. Also measures the speed in units per second. The number of points to be received on the IN A input, corresponding to one unit, must be defined from one up to 255. The maximum frequency on the IN A input is 40 kHz in both cases (without filtering). Response time: < 0.2 s (frequency 2/40 kHz), < 1 s (frequency 0.2 kHz).
Count events		This function provides the value of the number of pulses received on the IN A input during a selectable time unit. The time unit is configurable: 0.1s, 1s, 10 s or 1 minute. The IN B input can be used to reset the internal time basis which provides the time unit. The maximum number of pulses counted during a time unit is up to 65,535. The minimum pulse duration on the IN A input is 10 µs (without filtering). Response time: < 0.5 ms.
Measure time periods		Measures the elapsed time during an event or between two events (on IN A input) according to the selectable time base of 10 µs, 100 µs or 1 ms. The maximum event duration is 0.655, 6.55, or 65.5 seconds, respectively. The maximum frequency on the IN A input is 200 Hz. Response time: < 0.5 ms.
Down counting		The IN B input starts or restarts the counter by resetting the setpoint value defined by the high threshold value. When the counter is running, any pulse received on the IN A input decreases the counter. The counter stops when it reaches 0. The maximum setpoint value is 65,535. The maximum frequency on the IN A input is 40 kHz (without filtering). Response time: < 0.5 ms.
Loop (modulo) counting		The IN B input starts or restarts the counter by resetting the setpoint value to 0. The IN B input also triggers the capture of the previous counting value before the counter is reset to 0. When the counter is running, any pulse received on the IN A input increases the counter. The counter turns back to zero automatically when the pulse number received equals the modulo defined by the high threshold value. The maximum modulo value is 65,535. The maximum frequency on the IN A input is 40 kHz (without filtering). Response time: < 0.5 ms.
Up/down counting		The RST input starts or restarts the counter by resetting the preset value. When the counter is running, counting increases or decreases according to the pulses received on the IN A and IN B inputs (default settings: IN A increases the counter and IN B decreases the counter). By configuration: <ul style="list-style-type: none"> <input type="checkbox"/> the IN B input can define the counting direction of the pulses received on IN A. <input type="checkbox"/> the IN A and IN B inputs can receive the signals of an incremental encoder. The counter value is limited to 0 as low limit and to 65,535 as high limit. Response time: < 5 ms.
OUT 1 and OUT 2 output functions		According to requirements, each of the counting module's two outputs can be configured for one of the following operating modes: <ul style="list-style-type: none"> <input type="checkbox"/> No direct action. <input type="checkbox"/> The output is activated when the counter value is less than the low threshold. <input type="checkbox"/> The output is activated when the counter value is between the low threshold and the high threshold. <input type="checkbox"/> The output is activated when the counter value is greater than the high threshold. <input type="checkbox"/> A pulse is generated on the output when the low threshold is exceeded (when counting down). <input type="checkbox"/> A pulse is generated on the output when the low threshold is exceeded (when counting up). <input type="checkbox"/> A pulse is generated on the output when the high threshold is exceeded (when counting down). <input type="checkbox"/> A pulse is generated on the output when the high threshold is exceeded (when counting up). <input type="checkbox"/> The output is activated when the counter is in RUN mode. This option is only available when counting down <input type="checkbox"/> The output is activated when the counter is in STOP mode. <input type="checkbox"/> The output is activated when the capture value is less than the low threshold. This option is only available for the modulo function. <input type="checkbox"/> The output is activated when the capture value is between the low threshold and the high threshold. This option is only available for the modulo function.

Characteristics			
Electrical characteristics			
Type of module		STB EHC 3020	
Frequency on counting inputs	kHz	1 channel, up to 40 (1)	
Swapping	Cold swap	Yes	
	Hot swap	Yes, depending on NIM and mandatory nature of module. See table on page 41	
Mounting base		STB XBA 3000	
PDM power distribution module required	Voltage provided	V	24
	Catalog number	STB PDT 3100/3105	
Consumption on the logic bus	--- 5 V	mA	60 typical, 100 max.
Isolation	Between island bus and I/O	--- V	500
Input characteristics			
Input type		Counting inputs (IN A and IN B)	Auxiliary inputs (EN and RST)
Nominal values	Voltage	--- V	24 (limits 19.2...30 V)
	Current	mA	6
Limit values	At state 1	--- 11...30 V, current 2 mA minimum (at --- 11 V)	
	At state 0	--- - 3...5 V, current 1.5 mA maximum	
Logic		Positive	
Filter time	Analog	µs	2,5
	Digital	ms	None (max. count 40 kHz) 0.40 (max. count 1 kHz) 1.20 (max. count 400 kHz)
25			
-			
Output characteristics			
Output type		OUT 1 and OUT 2 outputs	
Rated voltage	--- V	24 (limits 19.2...30 V)	
Nominal current	A	0.5 (1 A per module)	
Logic		Positive (by default), positive on 1 or 2 channels, negative on 1 or 2 channels (configurable)	
Response time		See functional characteristics, page 78	
Leakage current	At state 0	mA	up to 0.1
Voltage drop	At state 1	V	up to 3
Max. load inductance		Henry	0.5 at 4 Hz, or $L = 0.5/I^2 \times F$ where L: load inductance, I: load-in current, and F: switching frequency
Short circuit and overload protection	Type per channel	By current limiter (1.1 A typical/1.5 A max.) and electronic tripping (manual or automatic reset)	
Default fallback positions	Default	Set to 0 state for both channels	
	Configured	Hold last value, set to state 0 or 1 for each channel	

(1) Use of grounding kit is mandatory for counting at 40 kHz.

Advantys™ STB Distributed I/O Solution

Counter module STB EHC 3020



STB XBA 3000



STB EHC 3020

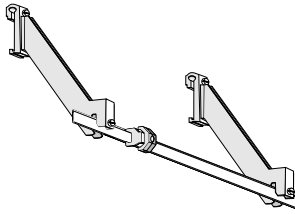

STB XSP 3000



STB XSP 3010/3020

Catalog numbers

Designation	Input type	Catalog number	Weight kg
Counter module 1 channel 40 kHz	2/3 wire --- 24 V detectors Incremental encoder --- 24 V Mechanical contacts	STBEHC3020	–

Mandatory separate parts

Designation	Use	Catalog number	Weight kg
Base 28.1 mm (1.10")	Module mounted on DIN rails	STBXBA3000	–
Removable connector (1)	18-pin spring-type	STBXTS2150	–

Optional separate parts

Designation	Use	Sold in lots	Catalog number	Weight kg
Grounding kit (2)	Grounding for shielded cables Composed of 1 bar, length 1 m (1.09 yd) and 2 lateral supports	–	STBXSP3000	–
Terminals for grounding kit	Cable widths 1.5 to 6 mm ² (0.06 to 0.23" ²)	10	STBXSP3010	–
	Cable widths 5 to 11 mm ² (0.19 to 0.43" ²)	10	STBXSP3020	–
Keying pin	Counter module	60	STBXMP7700	–
Sheets of customizing labels (3)	Customization of modules and bases	25	STBXMP6700	–

(1) All connectors can accommodate a flexible wire with maximum cross-section of 1.5 mm² (0.06" ²), including cable end piece.

(2) Grounding kit recommended (mandatory for high frequency counting).

(3) A template for the customizing labels is supplied with the documentation mini-CD-ROM.

Advantys™ STB Distributed I/O Solution

Counter module STB EHC 3020

Connections

Connection to STB XTS 2150 removable terminal block for spring-loaded terminals

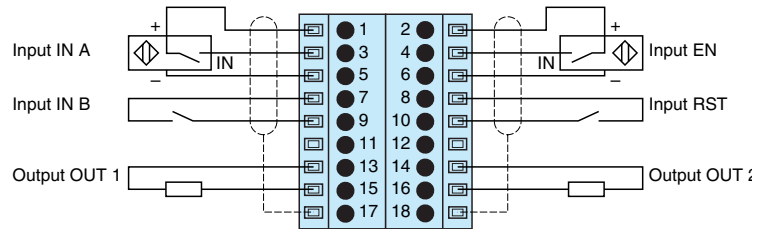

Note: The 24 V power supplies for the sensors and actuators are provided by the STB PDT 3100 power distribution module via the sensor and actuator buses of the Advantys STB island.

Grounding kit recommended.

Advantys™ STB Distributed I/O Solution

Configuration and debugging software

Presentation

Advantys STB SPU 1●●● software is a tool for configuring and debugging the range of distributed I/O solutions Advantys STB, OTB (IP20 protection) and FTB/FTM (IP67 protection). It also allows debugging and diagnosis of distributed I/O islands while in operation.

As far as the Advantys STB range is concerned, Advantys STB SPU 1●●● software can be used to:

- Define all I/O modules which go to make up an Advantys STB automation island.
- Configure standard type modules (basic modules have a fixed default configuration).
- Configure the reflex functions handled at the island level.
- Optimize island performance by assigning priorities for the processing of certain modules.
- Declare certain modules to be mandatory, i.e. modules whose presence and correct operation are required for the island to operate correctly.
- Declare external CANopen devices in the island (such as Advantys FTB IP67 monobloc I/O splitter boxes, Festo or Parker electropneumatic valves, Altivar® variable speed drives, other CANopen V4.0 devices etc.).
- Check the configuration for compliance and power consumption.

User interface

The main screen of the Advantys configuration and debugging application provides easy and intuitive access to all the available tools.

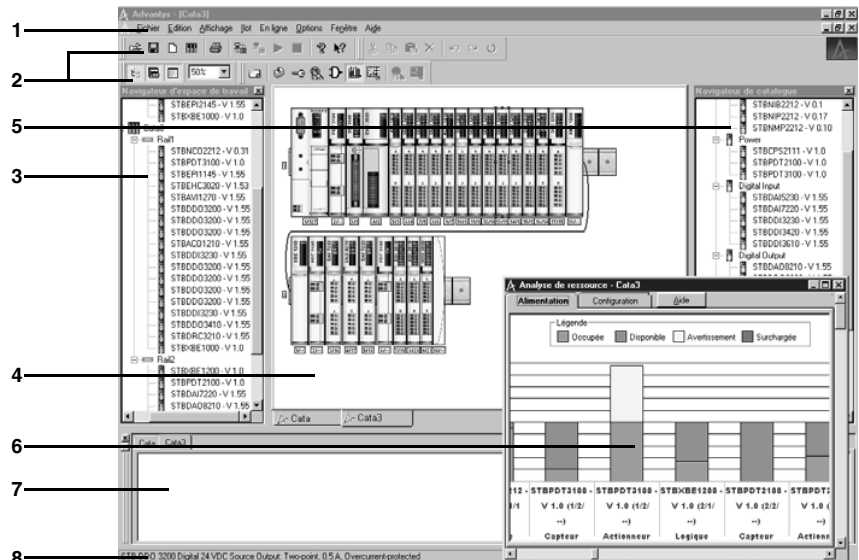

This main screen contains a general view comprising several windows and toolbars that can be moved about the screen:

- 1 Menu bar, giving access to all functions.
- 2 Toolbar containing icons used for direct access to editors and the most frequently used functions.
- 3 Browser, for browsing the various islands and segments of each island.
- 4 Main window for viewing islands and segments.
By selecting a module, you can access the appropriate editors:
 - Module Editor.
 - Reflex Action Editor.
 - Power supply and memory resource analysis.
 - Overview of the I/O image.
 - Diagnostics.
- 5 Catalog browser for all the Advantys STB components, sorted by category (networks, power supply, digital I/O, etc.).
- 6 Power supply and memory resource analysis window.
- 7 Log window displaying the results of operations performed by the configuration software during a work session on an island.
- 8 Status bar.

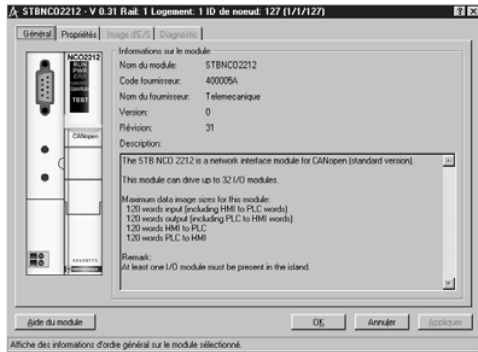

CANopen bus interface NIM module

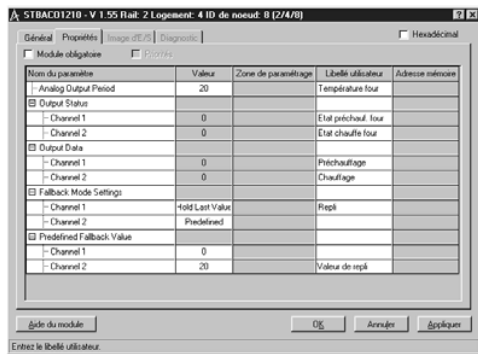

STB ACO1210 module with 2 analog output channels

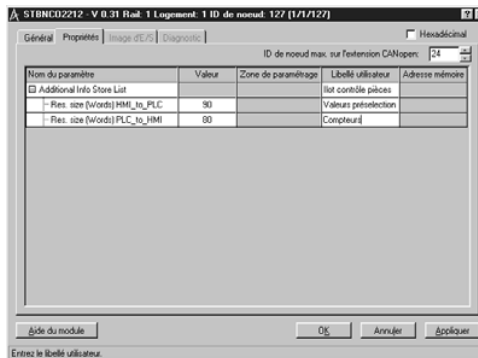

STB NCO 2212 CANopen bus interface module

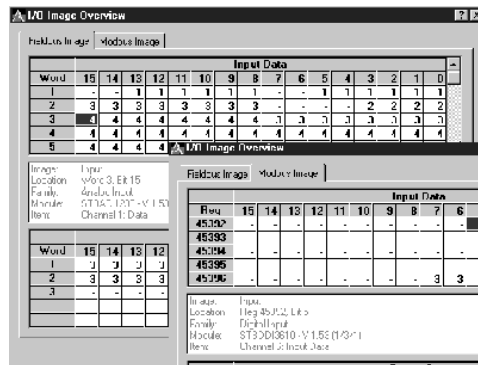

"I/O Image" tab

Functions

Module Editor

The editor gives access to 4 tabs, depending on the way in which the island is connected to the network or fieldbus: General, Properties, I/O Image and Diagnostics.

"General" tab

This read-only tab (island online or offline), provides general information and displays the key technical characteristics of the selected module.

"Properties" tab

This tab, accessible when the island is offline, contains the operating settings for the selected module, some of which can be changed by the user. Among other things, you can:

- Select the display format for parameters: decimal or hexadecimal.
- Identify a module as "mandatory." That module is then designated as critical for island operations. If the module fails or is not present, the island will no longer be operational (it will stop).
- Declare the scanning priority for the digital input module. This allows you to assign more frequent scanning to modules regarded as "fast" (up to 10 modules per island) compared with other modules.
- Module configuration. The configurable items (cells with white backgrounds) depend on the type of I/O module. Depending on the type of module, the main parameters are:
 - user label assignment, free text field for up to 50 characters (1).
 - digital input modules: filter time and choice of positive or negative logic for each channel.
 - digital output modules, the behavior upon short circuit or overload (manual or automatic reset), the choice of positive or negative logic for each channel, the default fallback position for each channel (0 or 1 state).
 - analog input modules, with the offset and scaling for each channel.
 - analog output modules, with the refresh rate and the default fallback position (hold the value or assume a predefined value) for each channel.
 - application-specific modules for TeSys® Quickfit or TeSys® Model U motor-starters, the choice of positive or negative logic for each channel, the behavior upon short circuit or overload (manual or automatic reset), and the default fallback position for each channel (0 or 1 state).
 - counter module, the definition of the counting function and its operation, see page 76.
 - network interface modules, the amount of memory reserved for data exchanges with the Operator Terminal (directly connected to the network interface module). This data is also accessible by the island's master device: If an Advantys STB island has a CANopen extension, a parameter allows you to define the address of the last standard CANopen device connected to the island. Online help for the selected module can be displayed to show the limits and operating values of these parameters.

"I/O Image" tab

This tab, accessible when the island is online, provides a table with data concerning the:

- Input/output modules comprising the Advantys STB island (values and state of each module).
- Operator Terminal connected to the network interface module. The length of this field (defined in the "Properties" tab of the network interface module) equals the maximum total size of the image table, less the words occupied by the image of the I/O modules. The total size of the I/O image table depends on the type of the network interface module. These I/O images can be displayed in two views:
 - Field bus or network view: each protocol transfers its data in a specific format.
 - Internal island bus view: the Modbus® protocol is used.

(1) A utility allowing the export of user labels (under CANopen) to the Premium PLC memory (under Unity Pro or PL7) is available. Please consult your Regional Sales Office.

Advantys™ STB Distributed I/O Solution

Configuration and debugging software

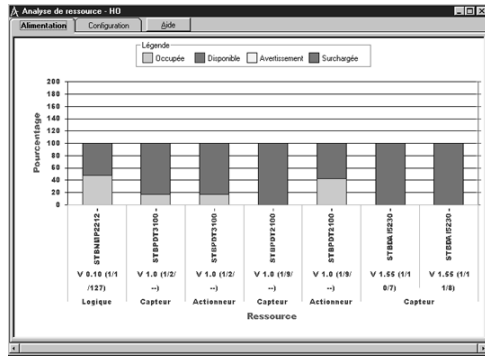

Power supply and memory resource analysis

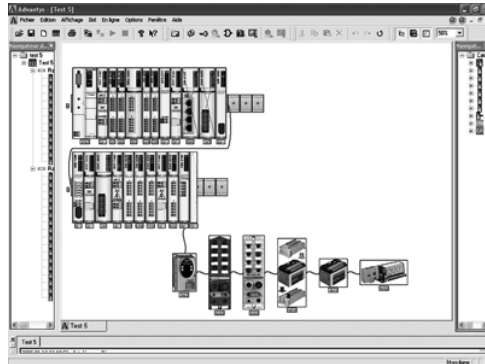

Access via RTP to external components such as Altivar® variable speed drives etc.

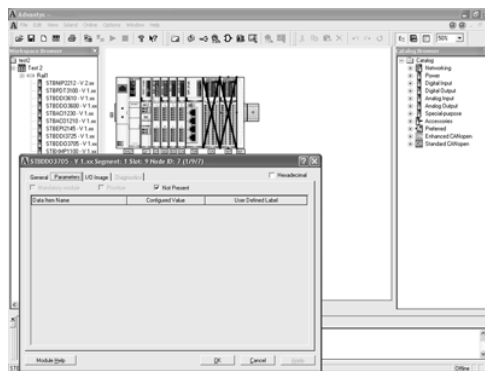

"Absent" modules will be actually installed if needed.

Functions (continued)

"Diagnostics" tab

This tab allows the user to perform diagnostics for the island connected to the PC terminal where the Advantys configuration and debugging software resides.

Analysis of the island's memory and power resources

At any time during the configuration process, you can consult the following information expressed as a percentage:

- The power consumption at various voltages:
 - the 5 V logic voltage provided by the STB N network interface module,
 - the 5 V logic voltage provided by the STB XBE 1200 BOS extension module,
 - the 5 V logic voltage provided by the STB CPS 2111 auxiliary power supply,
 - the 24 V voltage provided by the STB PDT 3100/3105 power distribution module(s),
 - the ~ 115/230 V voltages provided by the STB PDT 2100/2105 power distribution module(s),
- The usage of the memory integrated in the network interface module:
 - image field for inputs and outputs,
 - settings field for the island configuration data and reflex functions,
 - field dedicated to operator dialog.

Downloading configuration data

The software enables bi-directional transfer of configuration data:

- From the PC to the RAM and Flash memory of the island network interface module in order to make the island operational. If the network interface module includes the STB XMP 4440 32 KB removable memory card, data is written to the card, providing a backup.
- From the NIM interface module to the PC.

Run-time-parameters RTP

The RTP (*Run-Time Parameters*) function allows access from the PLC to all the data (1) of external CANopen components connected to an STB island.

The 2 main uses are:

- Writing the parameters of a component: FDR (*Faulty Device Replacement*) operation.
- Reading all variables for surveillance and diagnosis of any object connected to the island.

"Absent" modules

This function of the Advantys STB SPU 1 configuration and debugging software allows you to declare I/O modules which, to begin with, are not actually included in the island.

This means that:

- "virtual" module slots are reserved in the island configuration.
- the exchange data of the "virtual" modules are included in the tables of exchanges with the PLC.

The physical modules can be integrated into the automation island as and when real needs dictate.

(1) Data: configuration and adjustment parameters, and variables.

Functions (continued)

Export of user labels (“tags”)

The Advantys software allows you to create labels (symbol names) for all objects and I/O parameters of the Advantys STB configuration.

The “File/export” function exports these names at the same time as the mapping, regardless of the fieldbus or network used. This information is directly usable on all controllers. This means you do not have to declare I/O objects all over again and promotes consistency in the naming of machinery or equipment items.

Import/export of island mapping files

This function allows you to carry out mapping and export it in the format of any PLC programming software, regardless of the fieldbus or network.

Printing of design report

This function allows you to select topics to be sent to a printer or to a PDF or editable RTF file.

The following items can be selected:

- Graphic image of the island. See example above.
- All or part of the information of the island:
 - List of mandatory components, including accessories such as bases, connectors etc.
 - List of optional components, such as labels, keying pins, memory cards etc.
 - Information about the work space.
 - Information about the island.
 - Image of the island.
 - List of components.
 - Fieldbus I/O image.
 - Modbus® I/O image.
 - Reflex actions.
 - Use of resources.
 - Details of resource power supply.
 - Details of resource configuration.
 - Details of modules.
 - Notes.

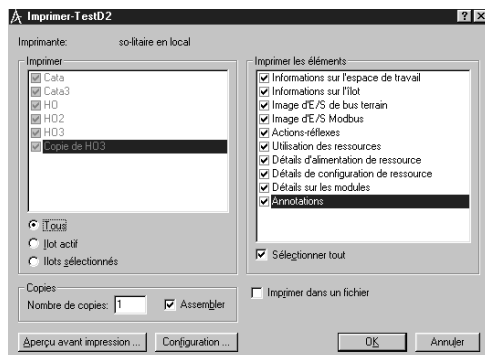

Printing: selection of islands and items to be inserted in the design report.

Test mode

There are two test modes:

■ **PLC offline test:** Bus or network communication is disconnected. The outputs can be controlled directly from the Advantys application connected via the Modbus socket of the NIM module.

■ **Online test:** Bus or network communication is operational. The outputs can be forced directly from the Advantys application. This mode can be accessed by entering a configurable password.

These test modes allow import of the island configuration or let you read error messages and I/O states.

Update at www.us.telemecanique.com

The Advantys STB SPU 1000 configuration and debugging software and the module catalog database are available online at web www.us.telemecanique.com.

Here you can:

- download the Advantys STB SPU 1000 software for a free 21-day trial period.
- for officially registered software, obtain all updates for functions and the catalog of components that can be connected to Advantys STB automation islands.

Functions (continued)

Reflex Functions Editor

For applications requiring short response times (< 3 ms), the Advantys STB Distributed I/O Solution allows you to create reflex functions using the configuration and debugging software. The reflex functions work directly at the level of the island output modules, so that they are not taken into account or processed by the island's master device. These reflex functions can be associated with "priority" I/O modules to ensure reliable response times.

An Advantys STB island can call up to 10 reflex functions. These functions are created from blocks whose inputs are activated by digital or analog input channels and whose results activate a digital or analog output channel. You can nest two reflex functions.

Reflex types and function blocks

Various types of function blocks are available:

Boolean logic function blocks: XOR block, AND blocks with 3 inputs and 1 output

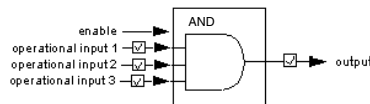

Timer/monostable blocks: when working, when idle, upon activation, and upon deactivation

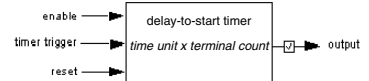

Rising/falling edge counting function blocks: on rising or falling edge, from 0 to 65,535

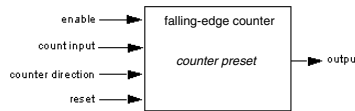

Compare function blocks on signed integers (-32,768 to 32,767): $i <$, $i >$, $< i >$, $i <$ and $i >$

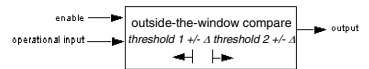

Digital Latch function blocks: on state 0 or 1 or on rising or falling edge, memorize state 0 or 1



Analog Latch function blocks: on state 0 or 1 or on rising or falling edge, memorize the signed integer (0 to 65,535) or unsigned integer (-32,768 to 32,767)

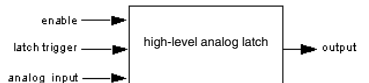

Documentation: A "Reflex actions" document is supplied on the CD-ROM STB SUS 8800 and on our website www.us.telemecanique.com.

Advantys™ STB Distributed I/O Solution

Configuration and debugging software



STB SPU 1 ●●●

Catalog numbers

The Advantys STB distributed I/O configuration and debugging software is multilingual and compatible with the operating systems Windows® 98 (Second Edition), Windows NT® 4.0 (Service Pack ≥ 6), Windows 2000 (Service Pack ≥ 1) and Windows XP (Service Pack ≥ 1).

Online help is available in 5 languages: English, French, German, Spanish and Italian. Internet Explorer (version 4.0 or higher) is required to access the on-line help.

Description	Use	Catalog number	Weight kg
Advantys configuration and debugging software	Single station - 1 workstation Includes a cable and a CD-ROM	STBSPU1000	-
	3 stations Includes 3 cables and 3 CD-ROMs	STBSPU1003	-
	10 stations Includes 10 cables and 10 CD-ROMs	STBSPU1011	-
	10 workstations on one site. Unlimited registration capacity. Includes 10 cables and 10 CD-ROMs	STBSPU1100	-
Subscription to Advantys configuration and debugging software Duration: 1 year	1 workstation	STBBBS1000	-
	3 stations	STBBBS1003	-
	10 stations	STBBBS1011	-
	10 workstations on one site. Unlimited registration capacity.	STBBBS1100	-

Documentation

User documentation (1)	Multilingual on CD-ROM	STBSUS8800	-
------------------------	------------------------	------------	---

Replacement parts

Connection cable from PC to network interface module	Length 2m	STBXCA4002	-
--	-----------	------------	---

Catalog numbers, Alliance SI program

Description	Use	Catalog number	Weight kg
Advantys configuration and debugging software	10 workstations on one site for a member of the Alliance SI program. Includes 10 cables and 10 CD-ROMs	STBSPU1010	-
Subscription to Advantys configuration and debugging software Duration: 1 year	10 workstations on one site for a member of the Alliance SI program	STBBBS1010	-

(1) 2 lots of documentation are available on the CD-ROM STB SUS 8800 and on our website www.us.telemecanique.com:

- "Advantys configuration and debugging software. Quick start-up guide."
- "Advantys configuration and debugging software. User manual."

STB No. 2212/1010

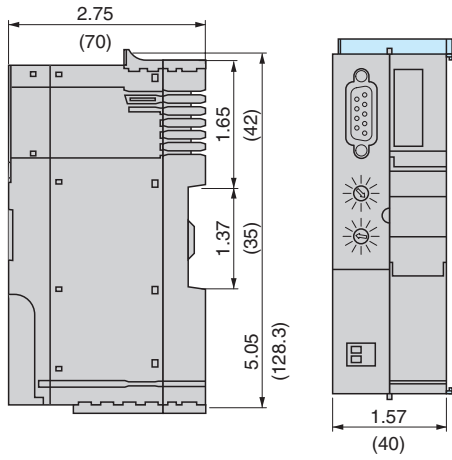

STB XBE 1000/1200/2100 and STB CPS 2111

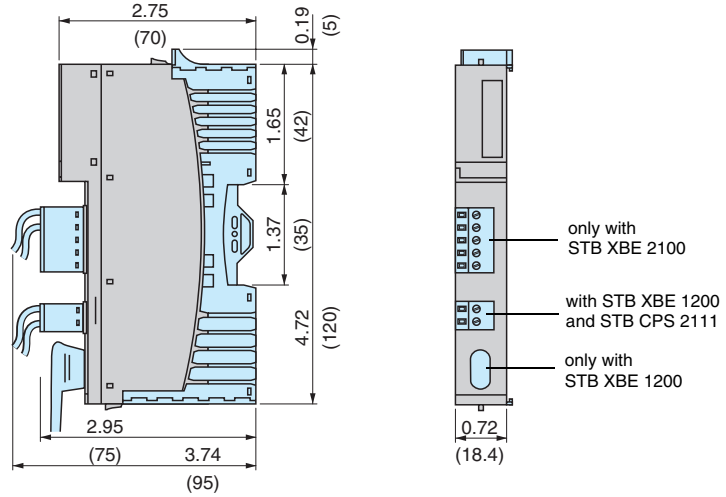

STB EHC 3020

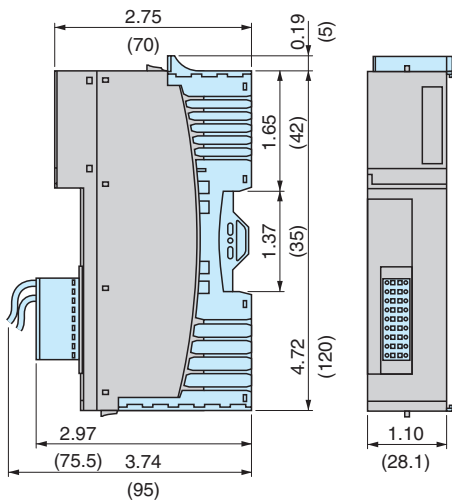

STB PDT 3100/2100 and 3105/2105

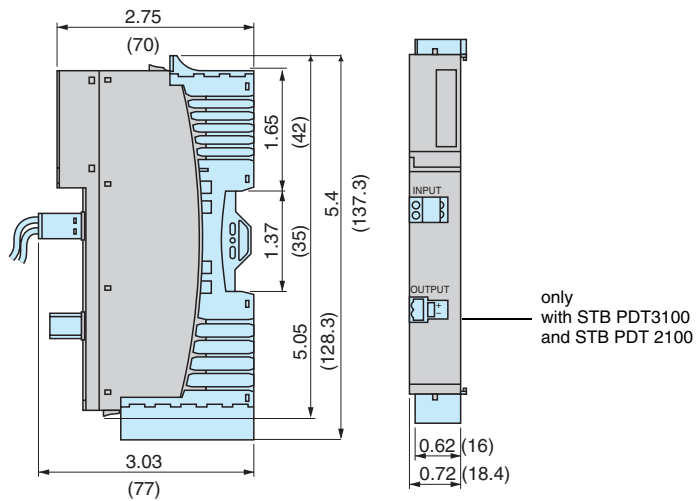

Inches
(mm)

STB DDI/DDO/DAI/DAO/AVI/ACI/ART/AVO/ACO/DRC/DRA

Side view

STB DDI/DDO 3●●0
STB DDI/DDO 3●●5
STB AVI/ART/AVO
STB ACI 1230/1225
STB ACO 1210/1225

STB DAI ●●●0/DAO 8210
STB DRC 3210
STB ACI 0320/8320
STB ACO 0220

STB DRA 3290

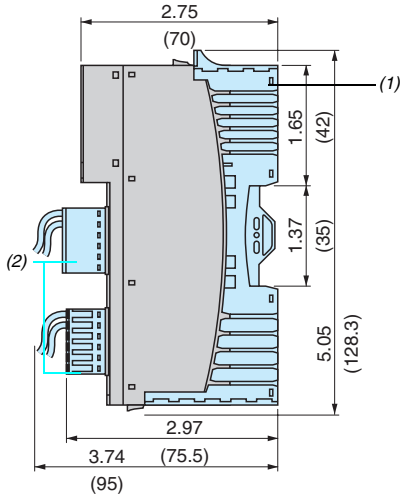

(1) STB XBA 1000/2000/3000 bases
(2) STB XTS 11●0/21●0 connectors

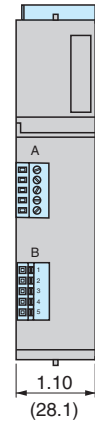
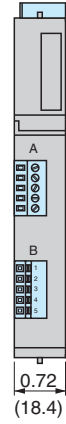
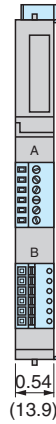

STB EPI 2145

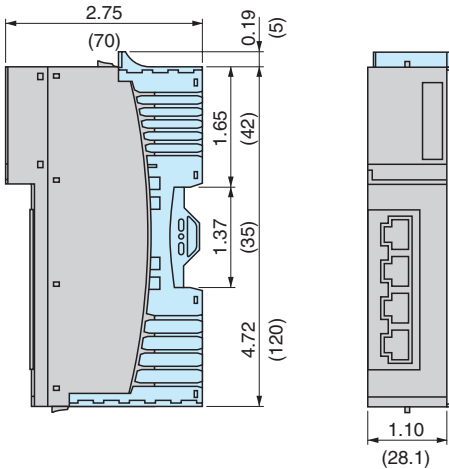

STB EPI 1145

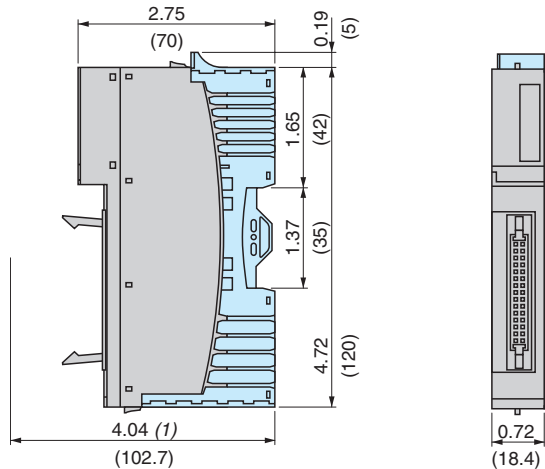

(1) With HE10 connector (30-pin).

Inches
(mm)

Advantys™ STB Distributed I/O Solution

Combination with Magelis® display units and operator interface terminals



STB NCO 2212 (door open) and STB XCA 4002 cable

Application

A display unit or Magelis XBT terminal can be connected directly to an Advantys STB island via the Modbus® programming port.

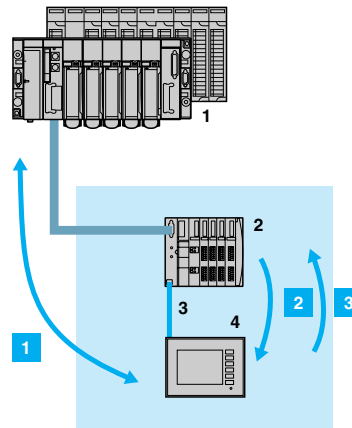

- 1 PLC.
- 2 Advantys STB distributed I/O island with standard type NIM communication module STB N●● 2212.
- 3 Modbus® serial cable and adapter if required. See compatibility table on next page.
- 4 Display unit or Magelis XBT operator dialog terminal.

Functions

With this architecture, the display unit or XBT terminal is the master of the Modbus® serial connection; the standard type Advantys STB communication module is the slave.

The connection allows:

- 1 Data transfer between the Magelis XBT terminal and the PLC via the exchange area defined by the user within the Advantys STB memory.
 - Two word tables have to be configured (sizes, labels) in the memory of the NIM communication module using the Advantys STB SPU 1●●● configuration software:
 - One written by the terminal and read by the PLC (HMI->PLC).
 - The other written by the PLC and read by the terminal (PLC->HMI).
 - The Advantys STB distributed I/O island is used as a neutral gateway between the PLC and the terminal.
 - The terminal can display information coming from the PLCs and, conversely, control automatic functions in the normal way.
- 2 Display of data of the Advantys STB island on the Magelis terminal:
 - Input and output values
 - Internal states
- 3 When the Advantys STB is in test mode, writing of output values of the island.

Note: Functions 2 and 3 :

- do not require communication to be established between the PLC and the Advantys STB island.
- cannot be performed simultaneously.

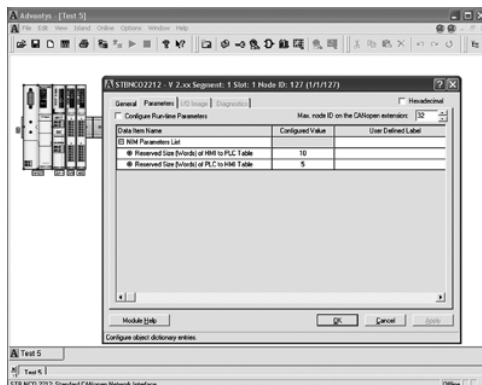

Configuring the exchange memory size with Advantys STB SPU 1●●● software

Advantys™ STB Distributed I/O Solution

Combination with Magelis® display units and operator interface terminals



XBT GT2220

Connection cables

Magelis family	Type	Size	Adapter	Length	Cable
XBT H	Display units		–	2.5 m (2.73 yd)	XBTZ988
XBT N (1)	Compact display units				
XBT E	Terminals				
XBT P					
XBT R (2)	Compact terminals				
XBT HM	Matrix display units				
XBT PM	Semi-graphic terminals				
XBT F	Touch screen graphic terminals and keyboards				
XBT G (3)	Graphic terminals		–	2 m (2.18 yd)	STBXCA4002
XBT G4320	Graphic terminals		–	2.5 m (2.73 yd)	XBTZ988
XBT G4330					
XBT GT11	Graphic terminals	3.8"	XBTZG939	2.5 m (2.73 yd)	XBTZ988
XBT GT2●	Touch screen graphic terminals	5.7"	–	2 m (2.18 yd)	STBXCA4002
XBT GT4●		7.5"			
XBT GT5●		10.4"			
XBT GT6●		12.1"			
XBT GT7●		15"			

(1) Except XBT N200 and XBT N400.

(2) Except XBT R400.

(3) Except:

– XBT G4320: connection cable XBT Z988.

– XBT G2110, XBT G2120, XBT G2220: no direct connection to an Advantys STB island.

Advantys™ STB Distributed I/O Solution

High-density I/O modules and Advantys™ Telefast® ABE 7 cabling system

Using the Advantys Telefast ABE 7 cabling system

Using the Advantys Telefast ABE 7 cabling system rationalizes and simplifies the cabling of enclosures.

Far less space is required in the enclosure and the Advantys Telefast ABE 7 base replaces the connection terminals at the bottom of the enclosure.

The Advantys Telefast ABE 7 prewiring system also provides a simple high-density logic I/O solution for the following voltages:

- \equiv 24 V.
- \equiv 48 V and \sim 48 V.
- \sim 110 V.
- \sim 230 V.

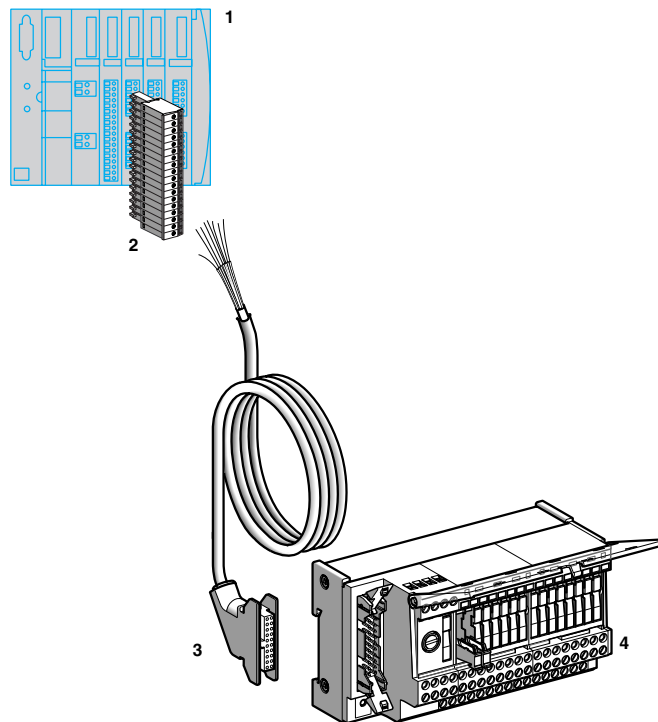

- 1 Advantys STB I/O island incorporating a high-density module STB DDI 3725 and/or STB DDO 3705.
- 2 18-pin connector STB XTS 1180 (screw type) or STB XTS 2180 (spring type).
- 3 Prewired cable TSX CDP 301 (length 3 meters), TSX CDP 501 (length 5 meters) or TSX CDP 1001 (length 10 meters), with HE 10 connector at one end, flying leads at other end.
Cross-section 0.324 mm^2 ($0.012''^2$), AWG 24.
- 4 Advantys Telefast ABE 7 connector or adapter base, see compatibility table opposite.

Note: For further information about the Advantys Telefast ABE 7 prewiring system, see our catalog "Interfaces, I/O splitter boxes and power supplies."

Advantys™ STB Distributed I/O Solution

High-density I/O modules and Advantys™ Telefast® ABE 7 cabling system

Combinations of Advantys STB high-density modules and Advantys Telefast ABE 7 system

Advantys STB module		High-density inputs STB DDI 3725	High-density outputs STB DDO 3705
Module base		STB XBA 3000	
18 pin connectors 2	screw	STB XTS 1180 (1)	
	spring	STB XTS 2180 (1)	
Prewired cable 3	Characteristics	Flying leads at Advantys module end. HE 10 connector at Advantys Telefast end. Wire cross-section 0.324 mm ² (0.012" ²), AWG 24.	
	Catalog numbers	TSX CDP 301 length 3 m (3.28 yd) TSX CDP 501 length 5 m (5.46 yd) TSX CDP 1001 length 10 m (10.9 yd)	
Advantys STB module		STB DDI 3725	STB DDO 3705
Passive connection bases (16 channels) 4			
Universal	ABE 7H16R●●	Compatible	Compatible
	ABE 7H16R●●E	Compatible	Compatible
	ABE 7H16S21	Compatible	Compatible
	ABE 7H16S43	Compatible	Compatible
	ABE 7H16F43	Compatible	Compatible
Miniature	ABE 7H16C10	Compatible	Compatible
	ABE 7H16C11	Compatible	Compatible
	ABE 7H16C21	Compatible	Compatible
	ABE 7H16C31	Compatible	Compatible
Input adapter active bases (16 channels) 4			
	ABE 7S16E2●●	Compatible	Compatible
	ABE 7 S16E2●●E	Compatible	Compatible
	ABE 7P16F310	Compatible	Compatible
	ABE 7P16F310E	Compatible	Compatible
	ABE 7P16F312	Compatible	Compatible
Output adapter active bases (16 channels) 4			
	ABE 7S16S●●●	Compatible	Compatible
	ABE 7S16S●●●E	Compatible	Compatible
	ABE 7R16S11	Compatible	Compatible
	ABE 7R16S11●E	Compatible	Compatible
	ABE 7R16T●●●	Compatible	Compatible
ABE 7P16T●●●	Compatible	Compatible	

	Compatible
	Not compatible

Important: The Advantys STB module can supply \pm 24 V power to the Advantys Telefast block provided the current does not exceed 50 mA per group of 4 channels. Otherwise an external power supply will be required, and only the 0 V reference should be connected between the Advantys STB module and the Advantys Telefast ABE 7 block.

(1) Supplied in pairs (2 connectors per module).

Advantys™ STB Distributed I/O Solution

High-density I/O modules and Advantys™
Telefast® ABE 7 cabling system

Examples of combinations for logic input module STB DDI 3725

Voltage V	Advantys base Telefast ABE 7
≡ 48	ABE7S16E2E1
~ 48	ABE7S16E2E0
~ 115	ABE7S16E2F0
~ 230...240	ABE7S16E2M0

Examples of combinations for logic output module STB DDO 3705

Type	Voltage V	Current per channel A	Advantys base Telefast ABE 7	Relay
Relay	≡ 24	0.5	ABE7S16S2B0	–
		0.5	ABE7S16S1B2	–
		≥ 0.7	ABE7P16T●●●● (1) ABE7P16F●●●● (1)	–
Relay	≡ 48	0.5	ABE7P16T2●●● (1)	ABS7C2E
Relay	~ 48	0.5	ABE7P16T2●●● (1)	ABS7SA2M
Relay	~ 115	0.5	ABE7P16T2●●● (1)	ABS7SA2M
Relay	~ 230...240	0.5	ABE7P16T2●●● (1)	ABS7SA2M
Static	~ 24...240	1.5	ABE7P16T3	ABS7SA3MA
Static	≡ 24...48	1.5	ABE7P16T3	ABS7SC3E
Static	≡ 24	2	ABE7P16T3	ABS7SC3BA
Economy relay	≡ 30	2	ABE7R16S●●●	–
Economy relay	≡ 30	2...5	ABE7R16S210/212	–
Economy relay	~ 230	2	ABE7R16S●●●	–
Economy relay	~ 230	2...5	ABE7R16S210/212	–

(1) Empty bases

Module connections STB DDI 3725 - TSX CDP ●01

Important: The inputs must be powered via the Advantys STB DDI 3725 module. (1)

STB DDI 3725		TSX CDP ●01		STB DDI 3725		TSX CDP ●01	
Left connector	Channel	HE 10		Right connector	Channel	HE 10	
A	IN			B	IN		
Terminal no.		Terminal no.	Color of wire	Terminal no.		Terminal no.	Color of wire
1	PDM V1 + (1)	17 (2)	White-gray	1	PDM V1 + (1)	19 (2)	White-pink
2	11	1	White	2	19	9	Black
3	-	-	-	3	-	-	-
4	12	2	Brown	4	110	10	Violet
5	-	-	-	5	-	-	-
6	13	3	Green	6	111	11	Gray-pink
7	-	-	-	7	-	-	-
8	14	4	Yellow	8	112	12	Red-blue
9	PDM V1 -	18 (3)	Gray-brown	9	PDM V1 -	20 (3)	Pink-brown
10	-	-	-	10	-	-	-
11	15	5	Gray	11	113	13	White-green
12	-	-	-	12	-	-	-
13	16	6	Pink	13	114	14	Brown-green
14	-	-	-	14	-	-	-
15	17	7	Blue	15	115	15	White-yellow
16	-	-	-	16	-	-	-
17	18	8	Red	17	116	16	Yellow-brown
18	-	-	-	18	-	-	-

- (1) Wires 17 and 19 of cable TSX CDP ●01 (terminals 1 of connectors on STB DDI 3725) should only be connected if the following two conditions are met:
 - no external power supply connected to the Telefast ABE 7 base
 - consumption does not exceed 50 mA per group of 4 channels
 (2) terminals 17 and 19 of the HE10 connected inside the ABE 7 base
 (3) terminals 18 and 20 of the HE10 connected inside the ABE 7 base

Module connections STB DDO 3705 - TSX CDP ●01

Important: The outputs must be powered via the Advantys Telefast ABE 7 base.

STB DDO 3705		TSX CDP ●01		STB DDO 3705		TSX CDP ●01	
Left connector	Channel	HE 10		Right connector	Channel	HE 10	
A	OUT			B	OUT		
Terminal no.		Terminal no.	Color of wire	Terminal no.		Terminal no.	Color of wire
1	OUT 1	1	White	1	OUT 9	9	Black
2	PDM V -	20 (1)	Pink-brown	2	PDM V -	18 (1)	Gray-brown
3	OUT 2	2	Brown	3	OUT 10	10	Violet
4	-	-	-	4	-	-	-
5	OUT 3	3	Green	5	OUT 11	11	Gray-pink
6	-	-	-	6	-	-	-
7	OUT 4	4	Yellow	7	OUT 12	12	Red-blue
8	-	-	-	8	-	-	-
9	NC	-	-	9	NC	-	-
10	OUT 5	5	Gray	10	OUT 13	13	White-green
11	-	-	-	11	-	-	-
12	OUT 6	6	Pink	12	OUT 14	14	Brown-green
13	-	-	-	13	-	-	-
14	OUT 7	7	Blue	14	OUT 15	15	White-yellow
15	-	-	-	15	-	-	-
16	OUT 8	8	Red	16	OUT 16	16	Yellow-brown
17	-	-	-	17	-	-	-
18	NC	-	-	18	NC	-	-

- NC: Not connected
 (1) terminals 18 and 20 of the HE10 connected inside the ABE 7 base

Advantys™ STB Distributed I/O Solution

Phaseo® Regulated Power Supplies

ABL 7 power supplies

The Phaseo® ABL 7 range of power supplies is designed to provide the DC voltage required by the control circuits of automation system equipment. Split into three families, this range meets all the needs encountered in industrial, commercial and residential applications. Single-phase or 3-phase (1), of the electronic switch mode type, they provide a quality of output which is suitable for the loads supplied and compatible with the mains supply available in the equipment. Clear guidelines are given on selecting protection devices which are often used with them, thus providing a comprehensive solution which can be used in total safety.

Phaseo switch mode power supplies

These switch mode power supplies are totally electronic and regulated. The use of electronics makes it possible to significantly improve the performance of these power supplies which offer:

- compact size,
- integrated overload, short-circuit, overvoltage and undervoltage protection,
- a very wide range of permissible input voltages, without any adjustment required,
- a high degree of output voltage stability,
- good performance,
- LED indicators on the front panel.



2/3 A power supply



5 A power supply



10 A power supply

Phaseo power supplies are available in single-phase and 3-phase versions (1). They deliver a voltage which is precise to 3%, whatever the load and whatever the type of mains supply, within a range of 85 to 264 V for single-phase, or 360 to 550 V for 3-phase. Conforming to IEC standards and UL and CSA certified, they are suitable for universal use. The inclusion of overload and short-circuit protection makes downstream protection unnecessary if discrimination is not required.

ABL 7 RE and ABL 7 RP supplies are also equipped with an output undervoltage control which causes the product to trip if the output voltage drops below 19 V, in order to ensure that the voltage delivered is always usable by the actuators being supplied. All the products are fitted with an output voltage adjustment potentiometer to compensate for any line voltage drops in installations with long cable runs. Most of our power supplies are designed for direct mounting on 35 (1.37") and 75 mm (2.95") rails.

The single-phase power supplies referenced in this catalog are specially adapted to be combined with the Advantys STB modules (Network Interface Modules and Power Distribution Modules).

■ Universal single-phase supplies **ABL 7RE:**

- power between 48 W (2 A) and 240 W (10 A),
- compact size,
- for all machine equipment,

- suitable for use in automation system environments based on any Modicon® platform requiring a --- 24 V supply.

■ Universal single-phase supplies **ABL 7RP:**

- power between 60 W (2.5 A) and 240 W (10 A),
 - output voltage available: --- 12, 24 and 48 V,
 - input filter (PFC) for commercial and residential environments (conforming to standard EN 61000-3-2),
 - two operating modes possible for handling of overload and short-circuit faults:
 - "AUTO" mode which provides automatic restarting of the power supply on elimination of the fault,
 - "MANU" mode which requires manual resetting of the power supply to restart.
- Resetting is achieved by switching off the mains power.

(1) For 3-phase power supplies, consult our catalog "Automation and control - Interfaces, I/O splitter boxes and power supplies."

Using --- 24 V

■ Using --- 24 V enables so-called protection installations (PELV) to be built. Using PELV is a measure designed to protect people from direct and indirect contact. Measures relating to these installations are defined in publication NF C 12-201 and in standard IEC 364-4-41.

■ The application of these measures to the electrical equipment in machines is defined in standard NF EN 60204-1 and requires:

- that the voltage used is below 60 V DC in dry environments and below 30 V in damp environments,
- the connection of one side of the PELV circuit, or one point of the source, to the equipotential protection circuit associated with higher voltages,
- the use of switchgear and control gear on which measures have been taken to ensure “safety separation” between power circuits and control circuits.

■ A safety separation is necessary between power circuits and control circuits in PELV circuits. Its aim is to warn of the appearance of dangerous voltages in --- 24 V safety circuits.

■ The reference standards involved are:

- IEC 61558-2-6 and EN 61558-2-6 (safety transformers),
- IEC 664 (coordination of isolation).

Telemecanique® power supplies meet these requirements.

■ Moreover, to ensure that these products will operate correctly in relation to the demands of their reinforced isolation, it is recommended that they be mounted and wired as indicated below:

- they should be placed on a grounded mounting plate or rail,
- they should be connected using flexible cables, with a maximum of two wires per connection, and tightened to the nominal torque,
- conductors of the correct insulation class must be used.

■ If the DC circuit is not connected to an equipotential protection conductor, an earth leakage detector will indicate any accidental insulation faults (please consult your Regional Sales Office).

Operating voltage

■ The permissible tolerances for the operating voltage are listed in publications IEC 1131-2 and DIN 19240.

■ For nominal voltage $U_n = \text{---} 24 \text{ V}$, the extreme operating values are from - 15% to + 20% of U_n , whatever the supply fluctuations in the range - 10% to + 6% (defined by standard IEC 38) and load variations in the range 0-100% of I_n .

All Telemecanique® --- 24 V power supplies are designed to provide a voltage within this range.

■ It may be necessary to use a voltage measurement relay to detect when the normal voltage limits are being exceeded and to deal with the consequences of this (please consult your Regional Sales Office).

Selection of power supplies

The characteristics to be taken into account when selecting a power supply are:

- the required output voltage and current,
- the mains voltage available in the installation.

This may however result in several products being selected as suitable.

Other selection criteria must therefore be taken into account.

There are 3 possible power supply options for Advantys STB modules:

- Option 1: a single power supply for the network interface module, sensors and actuators. Advantages: simple and low-cost.
- Option 2: 2 power supplies, 1 for the network interface module and 1 for the sensors/actuators. Advantage: separation of the bus and fieldbus.
- Option 3: 3 power supplies, 1 for the network interface module, 1 for the sensors and 1 for the actuators. Advantage: suitable for applications demanding minimum interference at the inputs (see power supply combination table on page 101).

The quality of the mains power supply

The Phaseo range is the ideal solution because it ensures precision to 3% of the output voltage, whatever the load current and the input voltage. In addition, the wide input voltage range of Phaseo power supplies allows them to be connected to all mains supplies within the nominal range, without any adjustment required.

The Phaseo RP family can also be connected to 110 and 220 V emergency supplies.

Harmonic pollution (power factor)

The current drawn by a power supply is not sinusoidal. This leads to the existence of harmonic currents which pollute the mains supply. European standard EN 61000-3-2 limits the harmonic currents produced by power supplies. This standard covers all devices between 75 W and 1000 W, drawing up to 16 A per phase, and connected directly to the public mains power supply. Devices connected downstream of a private, low voltage, general transformer are therefore excluded.

Regulated switch mode supplies always produce harmonic currents; a filter circuit (Power Factor Correction or PFC) must therefore be added to comply with standard EN 61000-3-2.

Phaseo ABL 7RP power supplies conform to standard EN 61000-3-2 and can therefore be connected directly to public mains power supplies.

Electromagnetic compatibility

Levels of conducted and radiated emissions are defined in standards EN 55011 and EN 55022.

All products in the Phaseo range have class B certification and can be used without any restrictions due to their low emissions.

Behavior in the event of short-circuits

Phaseo power supplies are equipped with an electronic protection device. This protection device resets itself automatically on elimination of the fault (around 1 second for ABL 7RE/RP), which avoids having to take any action or change a fuse. In addition, the Phaseo ABL 7RP ranges allow the user to select the reset mode in the event of a fault:

- in the "AUTO" position, resetting is automatic,
- in the "MANU" position, resetting occurs after elimination of the fault and after switching the mains power off and back on.

This feature allows Phaseo ABL 7RP power supplies to be used in installations where the risks associated with untimely restarting are significant.

Selection of reset mode

Reset mode is selected by the microswitch on the front panel of the product.

Technical characteristics			
Type of power supply		ABL 7RE	ABL 7RP
Approvals		UL, CSA, TÜV, CTick	
Conformity to standards	Security	UL 508, CSA 22.2 no. 950	
	EMC	EN 50081-1, IEC 61000-6-2 (EN 50082-2)	
	Low frequency harmonic currents	-	EN 61000-3-2
Input circuit			
LED indication		Orange LED	
Input voltages	Rated values	V	~ 100...240 --- 110...220 compatible (1)
	Permissible voltages	V	~ 85...264 single-phase --- 100...250 compatible (1)
	Permissible frequencies	Hz	47...63
	Efficiency at nominal load		> 85%
Current consumption	Ue = 240 V	A	0.6 (48 W)/0.83 (72 W) 1.2 (120 W)/2.5 (240 W)
	Ue = 100 V	A	1.2 (48 W)/1.46 (72 W) 1.9 (120 W)/3.6 (240 W)
	Current at switch-on	A	< 30
	Power factor		0.65 approx. 0.98 approx.
Output circuit			
LED indication		Green LED	
Nominal output voltage (U out)		V	--- 24 12, 24 and 48
Nominal output current		A	2/3/5/10 2,5/5/10
Accuracy	Output voltage		Adjustable from 100 to 120%
	Line and load regulation		± 3%
	Residual ripple - interference	mV	< 200 (peak-peak)
Micro-breaks	Holding time at I max and Ve min	ms	> 10 > 20
Temporary overloads	Permissible inrush current (U out > 19V)		See page 101
Protection against	Short-circuits		Permanent/automatic restart Permanent/automatic restart or restart after switching off mains power
	Overload		1.1 In
	Overvoltage		Tripping if U > 1.5 Un
	Undervoltage		Tripping if U < 0.8 Un
Operational and environmental characteristics			
Connections	Input	mm ²	2 x 2.5 (0.078 x 0.098")+ ground
	Output	mm ²	2 x 2.5 (0.078 x 0.098")+ ground, multiple output, depending on model
Ambient conditions	Storage temperature	°C (°F)	- 25... + 70 (- 77... + 158)
	Operating temperature	°C (°F)	0... + 60 (32... + 140); derating as from 50°C (122°F), mounted vertically
	Max. relative humidity		95% without condensation
	Degree of protection		IP 20 conforming to IEC 529
	Vibrations		Conforming to EN 61131-2
Operating position			Vertical
MTBF at 40°C (104°F)			> 100,000 h
Connections	Serial		Possible
	Parallel		Possible, max. temperature 50°C (122°F)
Dielectric strength	Input/output		3000 V/50 and 60 Hz 1 minute
	Input/ground		3000 V/50 and 60 Hz 1 minute
	Output/ground (and output/output)		500 V/50 and 60 Hz 1 minute
Input fuse incorporated			Yes, not interchangeable
Disturbance			EN 50081-1
	Conducted		EN 55011/EN 55022 cl.B
	Radiated		EN 55011/EN 55022 cl.B
Immunity			IEC 61000-6-2 (generic)
	Electrostatic discharge		EN 61000-4-2 (4 kV contact/8 kV air)
	Electromagnetic		EN 61000-4-3 lev.3 (10 V/m)
	Conducted interference		EN 61000-4-4 lev.3 (2 kV), EN 61000-4-5, EN 61000-4-6 lev.3, EN 61000-4-8 lev. 4.
	Mains interference		EN 1000-4-11 (voltage drops and cuts)

(1) Compatible input voltage, not indicated on the product.

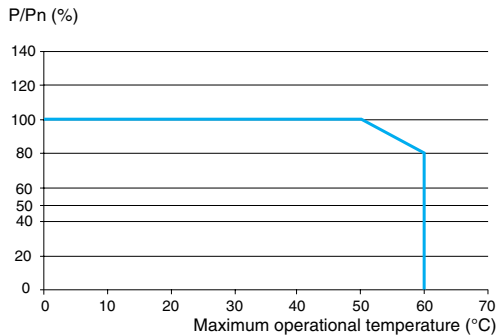

Derating

The ambient temperature is a determining factor which limits the power that an electronic power supply can deliver continuously. If the temperature around the electronic components is too high, their life will be significantly reduced. Conversely, a power supply can deliver more than its nominal power if the ambient temperature remains largely below the rated operating temperature.

The rated ambient temperature for Phaseo power supplies is 50°C (122°F). Above this, derating is necessary up to a temperature of 60°C (140°F).

The adjacent graph shows the power P (in relation to the nominal power Pn) which the power supply can deliver continuously, according to the ambient temperature (in a vertical position).

Derating should be considered in extreme operating conditions:

- Intensive operation (output current permanently close to the nominal current, combined with a high ambient temperature).
- Output voltage set above 24 V (to compensate for line voltage drops, for example).
- Parallel connection to increase the total power.

General rules to be complied with

Intensive operation	See derating on above graph. Example for ABL 7RE: □ without derating, from 0°C to 50°C (32°F to 122°F), □ derating of nominal current by 2%, per additional °C, up to 60°C (140°F).
Rise in output	The nominal power is fixed. Increasing the output voltage means that the current delivered must be reduced.
Parallel connection to increase the power	The total power is equal to the sum of the power of the power supplies used, but the maximum ambient temperature for operation is 50°C (122°F). To improve heat dissipation, the power supplies must not be in contact with each other.

In all cases, there must be adequate convection round the products to ensure easier cooling. There must be a clear space of 50 mm (1.96") above and below Phaseo power supplies and of 15 mm (0.60") at the sides.

Load limit

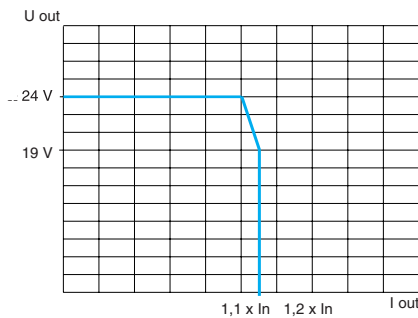

Temporary overloads

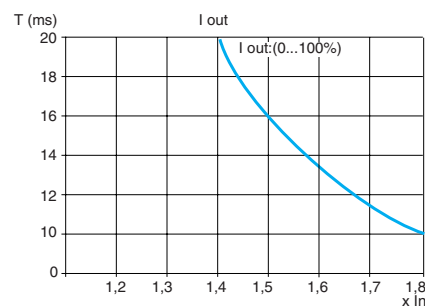

ABL 7RE and ABL 7RP power supply: protection of the power supply line

Type of mains supply	~ 115 V single-phase				~ 230 V single-phase	
	Thermal-magnetic circuit-breaker		gG fuse	Thermal-magnetic circuit-breaker		gG fuse
	GB2	C60N		GB2	C60N	
ABL7RE2402	GB2 ●B07	MG24517 (1)	2 A	GB2 DB06	MG24517 (1)	2 A
ABL7RE2403	GB2 ●B07	MG24517 (1)	2 A	GB2 DB06	MG24518 (1)	2 A
ABL7RE2405	GB2 ●B08	MG24518 (1)	4 A	GB2 DB07	MG24518 (1)	2 A
ABL7RE2410	GB2 ●B12	MG17454 (1)	6 A	GB2 DB08	MG24516 (1)	4 A
ABL7RP2403	GB2 ●B07	MG24517 (1)	2 A	GB2 DB07	MG17453 (1)	2 A
ABL7RP2405	GB2 ●B07	MG24517 (1)	2 A	GB2 DB07	MG24516 (1)	2 A
ABL7RP2410	GB2 ●B09	MG24519 (1)	4 A	GB2 DB07	MG24516 (1)	2 A

(1) UL certified circuit breaker.

Combinations of Phaseo single-phase power supplies with Advantys STB modules

Type of Advantys STB modules	NIM network interface module STB N●● 2212/1010 BOS bus extension module STB XBE 1200 Auxiliary power supply STB CPS 2111	PDM power distribution module STB PDT 3100/3105 (1) Sensors	Actuators
Installation for Advantys STB with 1 power supply	ABL7RP2410 (10 A)		
2 power supplies	ABL7RE/RP2402 (2 A)	ABL7RP2410 (10 A)	
3 power supplies	ABL7RE/RP2402 (2 A)	ABL7RE/RP2405 (5 A)	ABL7RP2410 (10 A)

(1) With basic power distribution module STB PDT 3105, installation with 1 or 2 power supplies only.

If the nominal current values for Phaseo power supplies are exceeded, multiple power supplies can be used to power NIM, BOS, CPS and PDT modules in accordance with the above rules (1, 2 or 3 power supplies).

NB:

- --- 24 V power supplies. The input current of the power supplies is:
 - Network interface module NIM STB N●●: 0.4 A.
 - Bus extension module BOS STB XBE 1200: 0.3 A.
 - Auxiliary power supply STB CPS 2111: 0.3 A.
- Power distribution modules, the maximum current is:
 - STB PDT 3100 for sensors: 4 A at 30°C (86°F), 2.5 A at 60°C (140°F).
 - STB PDT 3100 for actuators: 8 A at 30°C (86°F), 5 A at 60°C (140°F).
 - STB PDT 3105 for sensors/actuators: 4 A at 30°C (86°F), 2.5 A at 60°C (140°F).
- ABL 7RE power supply: built-in auto-protect with auto-reset.
- ABL 7RP power supply: built-in auto-protect with auto-reset or manual reset. EN 61000-3-2 compliant.

Catalog numbers (1)



ABL 7RE2405
ABL 7RP2405

ABL 7RE single-phase regulated switch mode power supplies

Mains input voltage 47...63 Hz	Output voltage	Nominal power	Nominal current	Auto-protect reset	Conforming to standard EN 61000-3-2	Catalog number	Weight
V	--- V	W	A				kg
~ 100...240 single-phase wide range	24	48	2	auto	no	ABL7RE2402	0.520
		72	3	auto	no	ABL7RE2403	0.520
		120	5	auto	no	ABL7RE2405	1.000
		240	10	auto	no	ABL7RE2410	2.200

ABL 7RP single-phase regulated switch mode power supplies

Mains input voltage 47...63 Hz	Output voltage	Nominal power	Nominal current	Auto-protect reset	Conforming to standard EN 61000-3-2	Catalog number	Weight
V	--- V	W	A				kg
~ 100...240 single-phase wide range --- 110...220 (2)	24	72	3	auto/man	yes	ABL7RP2403	0.520
		120	5	auto/man	yes	ABL7RP2405	1.000
		240	10	auto/man	yes	ABL7RP2410	2.200

(1) For other Phaseo power supplies, consult our catalog "Automation and control - Interfaces, I/O splitter boxes and power supplies."

(2) Compatible input voltage, not indicated on the product.

Dimensions

ABL7RE2405/ABL7RP2405

ABL7RE2402/2403
ABL7RP2403

ABL7RE2405
ABL7RP2405

ABL7RE2410
ABL7RP2410

Common side view

Mounting on 35 (1.37") and 75 mm (2.95") rails

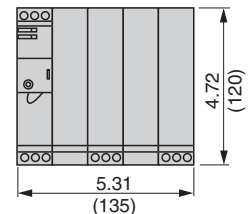
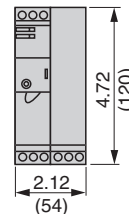
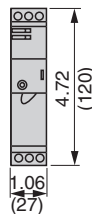
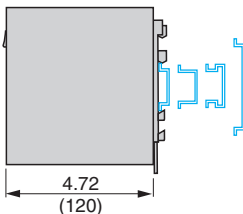

Technical information

Automation products certifications







In some countries, certification of certain electrical components is enforced by law. A standard conformity certificate is then issued by the official organization. Each certified product must carry approval symbols when enforced. Use on board merchant navy vessels generally requires prior approval (= certification) of an electrical device by certain marine classification authorities.

Key	Certification body	Country
CSA	Canadian Standards Association	Canada
C-Tick	Australian Communication Authority	Australia
GOST	Gost Standard Scientific Research Institute	C.I.S., Russia
UL	Underwriters Laboratories	USA
Key	Classification authority	Country
IACS	International Association of Classification Societies	International
ABS	American Bureau of Shipping	USA
BV	Bureau Veritas	France
DNV	Det Norske Veritas	Norway
GL	Germanischer Lloyd	Germany
LR	Lloyd's Register	United Kingdom
RINA	Registro Italiano Navale	Italy
RMRS	Russian Maritime Register of Shipping	C.I.S.

The table below shows the situation as at 01.10.2006 for certifications obtained or pending from organizations for base PLCs. An overview of certificates for Telemecanique products is available on our Internet website:

www.telemecanique.com

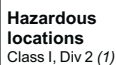
Product certifications

	Approvals					
						
	UL	CSA	ACA	GOST		ATEX
	USA	Canada	Australia	CIS, Russia	USA, Canada	Europe
Advantys STB					FM	
Advantys Telefast ABE 7						
ConneXium					(2)	
Magelis iPC	(3)				UL	
Magelis XBT GT						Cat 3 G-D
Magelis XBT F/FC/HM/PM						
Magelis XBT N/R					CSA/UL	Cat 3 G-D
Modicon M340					CSA	
Modicon Momentum						
Modicon Premium				(2)	CSA	
Modicon Quantum				(2)	FM (2)	
Modicon TSX Micro						
Twido	(3)	(2)			UL (2)	

(1) **Hazardous locations:** UL 1604, CSA 22.2 no. 213 or FM 3611, certified products are acceptable for use in hazardous locations of Class I, division 2, groups A, B, C and D or unclassified only.

(2) Depending on product, consult our website: www.telemecanique.com

(3) cULus North American certification (Canada and USA).

Local certifications







BG	Germany	TSX DPZ 10D2A safety module (TSX Micro). TSX PAY 262/282 safety modules (Premium).
SIMTARS	Australia	Modicon TSX Micro automation platform Modicon Premium automation platform (PL7)
AS-Interface	Europe	TWD NOI 10M3 master module (Twido). TSX SAZ 10 master module (TSX Micro). TSX SAY 1000 master modules (Premium).

Technical information

Automation products certifications

Community regulations

Marine classification

	Marine classification authorities						
	 ABS	 BV	 DNV	 GL	 LR	 RINA	 RMRS
	USA	France	Norway	Germany	UK	Italy	C.I.S.
	Certified						
	Pending certification						
Advantys STB	(1)						
Advantys Telefast ABE 7							
ConneXium				(2)			
Magelis iPC							
Magelis XBT GT							
Magelis XBT F/FC/HM/PM							
Magelis XBT N/R							
Modicon M340	(3)						
Modicon Momentum							
Modicon Premium (4)	(2)	(2)	(2)	(2)	(2)	(2)	(2)
Modicon Quantum				(2)		(2)	
Modicon TSX Micro							
Twido			(2)	(2)	(2)		

- (1) Also meets US Navy requirements, **ABS-NRV** part 4.
 (2) Depending on product, consult our website: www.telemecanique.com.
 (3) Request for Marine certifications forecast 1st quarter of 2007.
 (4) Modicon Premium, also **KRS** (Korean register of Shipping) certified.

Community regulations

European directives

The opening of European markets implies a harmonization of regulations in the various European Union member states. European Directives are documents used to remove obstacles to the free movement of goods and their application is compulsory in all states of the European Union. Member states are obliged to transcribe each Directive into their national legislation and, at the same time, to withdraw any conflicting regulations. The Directives, particularly those of a technical nature with which we are concerned, only set objectives, called "general requirements". The manufacturer must take all necessary measures to ensure that his products conform to the requirements of each Directive relating to his equipment. As a general rule, the manufacturer affirms that his product conforms to the necessary requirements of the Directive(s) by applying the e label to his product. The e marking is applied to Telemecanique products where relevant.

The significance of e marking

- b The e marking on a product means that the manufacturer certifies that his product conforms to the relevant European Directives; it is necessary in order that a product which is subject to a Directive(s) can be marketed and freely moved within the European Union.
- b The e marking is intended solely for the national authorities responsible for market regulation.

For electrical equipment, conformity of the product to standards indicates that it is suitable for use. Only the guarantee of a recognized manufacturer provides an assurance of high quality. One or more Directives, as appropriate, may apply to our products, in particular:

- b The Low Voltage Directive 72/23/EEC amended by Directive 93/68/EEC: The e marking under the terms of this Directive is compulsory as of January 1, 1997.
- b The Electromagnetic Compatibility Directive 89/336/EEC, amended by Directives 92/31/EEC and 93/68/EEC: The e marking on the products covered by this Directive has been compulsory since January 1, 1996.
- b Directive e ATEX 94/9/EC.

Principle

The 5 V logic power supply for the I/O modules is provided by the following modules:

- **NIM network interface module** placed at the beginning of the primary segment.
- **BOS bus extension module** placed at the beginning of each extension segment.
- **CPS auxiliary power supply** placed within a segment.

The NIM, BOS and CPS modules use their 24 V power supply to deliver a maximum current of 1200 mA at a voltage of 5 V.

The power consumption per segment must be calculated to ensure that the current demanded by the I/O modules does not exceed the current supplied by the different power supply modules.

If necessary, add an auxiliary power supply STB CPS 2111 in the segment(s) concerned.

Using the table on the next page

For each segment:

- In the "Number" column indicate the required number of I/O modules for each reference.
- In the "Total" column calculate the total current based on that number.
- In box 1 enter the grand total of all these values (mA).
- The grand total in box 1 must be less than or equal to 1200 mA, box 2. If it is greater, add an auxiliary power supply module, box 3.

The Advantys STB SPU 1 configuration and debugging software calculates the power consumption automatically. You can also use an Excel spreadsheet available from your Regional Sales Office or from www.telemechanique.com.

Segment	I/O module reference	Combined with base	Removable connectors (1)	PDM power distribution modules (standard/basic)	Number of I/O modules in the segment	Power consumption in mA at --- 5 V				
						Per I/O module	Total			
Digital inputs	STBDDI3230	XBA 1000	XTS ●100	PDT 3100/3105		70				
	STBDDI3420	XBA 1000	XTS ●100	PDT 3100/3105		60				
	STBDDI3425	XBA 1000	XTS ●100	PDT 3100/3105		60				
	STBDDI3610	XBA 1000	XTS ●100	PDT 3100/3105		70				
	STBDDI3615	XBA 1000	XTS ●100	PDT 3100/3105		70				
	STBDDI3725	XBA 3000	XTS ●180	PDT 3100/3105		150				
	STBDAI5230	XBA 2000	XTS ●110	PDT 2100/2105		50				
	STBDAI 5260	XBA 2000	XTS ●110	PDT 2100/2105		50				
	STB DAI7220	XBA 2000	XTS ●110	PDT 2100/2105		50				
	Digital outputs	STBDDO3200	XBA 1000	XTS ●100		PDT 3100/3105			60	
STBDDO3230		XBA 1000	XTS ●100	PDT 3100/3105	60					
STBDDO3410		XBA 1000	XTS ●100	PDT 3100/3105	80					
STBDDO3415		XBA 1000	XTS ●100	PDT 3100/3105	80					
STBDDO3600		XBA 1000	XTS ●100	PDT 3100/3105	90					
STBDDO3605		XBA 1000	XTS ●100	PDT 3100/3105	90					
STBDDO3705		XBA 3000	XTS ●180	PDT 3100/3105	150					
STBDAO5260		XBA 2000	XTS ●110	PDT 2100/2105	70					
STBDAO8210		XBA 2000	XTS ●110	PDT 2100/2105	70					
STBDRC3210		XBA 2000	XTS ●110	PDT 3100/3105	60					
STBDRA3290		XBA 2000	XTS ●110	PDT 3100/3105	70					
Analog inputs		STBAVI1270	XBA 1000	XTS ●100	PDT 3100/3105		60			
		STBAVI1275	XBA 1000	XTS ●100	PDT 3100/3105		60			
	STBAVI1255	XBA 1000	XTS ●100	PDT 3100/3105	60					
	STBACI1230	XBA 1000	XTS ●100	PDT 3100/3105	60					
	STBACI1225	XBA 1000	XTS ●100	PDT 3100/3105	60					
	STBACI0320	XBA 2000	XTS ●100	PDT 3100/3105	250					
	STBACI8320	XBA 2000	XTS ●100	PDT 3100/3105	250					
	STBART0200	XBA 1000	XTS ●100	PDT 3100/3105	55					
	Analog outputs	STBAVO1250	XBA 1000	XTS ●100	PDT 3100/3105			80		
		STBAVO1265	XBA 1000	XTS ●100	PDT 3100/3105			80		
STBAVO1255		XBA 1000	XTS ●100	PDT 3100/3105	80					
STBACO1210		XBA 1000	XTS ●100	PDT 3100/3105	80					
STBACO1225		XBA 1000	XTS ●100	PDT 3100/3105	80					
Application-specific modules	STBEP1145	XBA 2000	-	PDT 3100/3105		110				
	STBEP1245	XBA 3000	-	PDT 3100/3105		110				
	STBEHC3020	XBA 3000	XTS 2150	PDT 3100/3105		100				
Extension modules	STBxBE1000	XBA 2400	-	-		25				
	STBxBE2100	XBA 2000	XTS ●110	-		100				
Consumption per segment						1				
										
NIM network interface modules						2				
Ethernet TCP/IP	STBNIP2212	-	XTS ●120	Primary segment		1200 mA				
CANopen	STBNCO2212	-	XTS ●120							
	STBNCO1010	-	XTS ●120							
Modbus Plus	STBNMP2212	-	XTS ●120							
Fipio	STBNFP2212	-	XTS ●120							
INTERBUS	STBNIB2212	-	XTS ●120							
	STBNIB 1010	-	XTS ●120							
Profibus DP	STBNDP2212	-	XTS ●120							
	STBNDP1010	-	XTS ●120							
DeviceNet	STBNDN2212	-	XTS ●120+XTS ●110							
	STB NDN1010	-	XTS ●120+XTS ●110							
BOS bus extension module	STBxBE1200	-	XTS ●120	Extension segment		2 1200 mA				
Auxiliary power supply module	STBCPS2111	-	XTS ●120	Primary or extension segment		3 1200 mA				

(1) For screw-type connector replace ● with 1, for spring-type connector replace with 2

170BNO67100	23	STBDDI3230	105	STBXCA4002	91
170MCI00700	23	STBDDI3230	46	STBXMP1100	20
170MCI02010	22	STBDDI3420	105	STBXMP4440	20
170MCI02036	22	STBDDI3420	46	STBXMP5600	31
170MCI02080	22	STBDDI3425	105	STBXMP6700	25
170MCI02120	22	STBDDI3425	46	STBXMP6700	31
170MCI10000	23	STBDDI3610	105	STBXMP6700	47
170XTS02000	22	STBDDI3610	46	STBXMP6700	63
490NAD91103	23	STBDDI3615	105	STBXMP6700	72
490NAD91104	23	STBDDI3615	46	STBXMP6700	75
490NAD91105	23	STBDDI3725	105	STBXMP6700	80
490NTW00002	21	STBDDI3725	46	STBXMP7700	25
490NTW00002	72	STBDDO3200	105	STBXMP7700	31
490NTW00005	21	STBDDO3200	46	STBXMP7700	47
490NTW00005	72	STBDDO3230	105	STBXMP7700	63
490NTW00012	21	STBDDO3230	46	STBXMP7700	72
490NTW00012	72	STBDDO3410	105	STBXMP7700	75
490NTW00040	21	STBDDO3410	46	STBXMP7700	80
490NTW00080	21	STBDDO3415	105	STBXMP7800	25
990NAD21110	22	STBDDO3415	46	STBXMP7800	47
990NAD21130	22	STBDDO3600	105	STBXMP7800	63
990NAD23000	22	STBDDO3600	46	STBXMP7810	31
990NAD23010	22	STBDDO3605	105	STBXSP3000	31
ABL7RE2402	101	STBDDO3605	46	STBXSP3000	63
ABL7RE2402/2403	101	STBDDO3705	105	STBXSP3000	80
ABL7RE2403	101	STBDDO3705	46	STBXSP3010	31
ABL7RE2405	101	STBDRA3290	105	STBXSP3010	63
ABL7RE2405	101	STBDRA3290	46	STBXSP3010	80
ABL7RE2410	101	STBDRC3210	105	STBXSP3020	31
ABL7RE2410	101	STBDRC3210	46	STBXSP3020	63
ABL7RP2403	101	STBEHC3020	105	STBXSP3020	80
ABL7RP2403	101	STBEHC3020	80	STBXTS1100	47
ABL7RP2405	101	STBEPI1145	105	STBXTS1100	63
ABL7RP2405	101	STBEPI1145	75	STBXTS1110	24
ABL7RP2410	101	STBEPI2145	105	STBXTS1110	47
ABL7RP2410	101	STBEPI2145	72	STBXTS1111	20
APP2R2E	75	STBNCO1010	20	STBXTS1111	23
APP2R4E	75	STBNCO2212	20	STBXTS1120	20
ASMBKT085	22	STBNDN1010	20	STBXTS1120	24
LU9R03	72	STBNDN2212	20	STBXTS1130	31
LU9R10	72	STBNDP1010	20	STBXTS2100	47
LU9R30	72	STBNDP2212	20	STBXTS2100	63
SR2CBL06	20	STBNFP2212	20	STBXTS2110	24
STB DAI7220	105	STBNIB1010	20	STBXTS2110	47
STBACI0320	105	STBNIB2212	20	STBXTS2111	20
STBACI0320	62	STBNIP2212	20	STBXTS2111	23
STBACI1225	105	STBNMP2212	20	STBXTS2120	20
STBACI1225	62	STBPDT2100	31	STBXTS2120	24
STBACI1230	105	STBPDT2105	31	STBXTS2130	31
STBACI1230	62	STBPDT3100	31	STBXTS2150	80
STBACI8320	105	STBPDT3105	31	STBXTS2180	47
STBACI8320	62	STBSPU1000	87	STBXTT0220	25
STBACO0220	62	STBSPU1003	87	STBXTT0220	31
STBACO1210	105	STBSPU1010	87	STBXTT0220	63
STBACO1210	62	STBSPU1011	87	TSXCANCADD03	21
STBACO1225	105	STBSPU1100	87	TSXCANCADD1	21
STBACO1225	62	STBSUS8800	20	TSXCANCADD3	21
STBART0200	105	STBSUS8800	87	TSXCANCADD5	21
STBART0200	62	STBXBA1000	47	TSXCANCADD5	21
STBAVI1255	105	STBXBA1000	63	TSXCANCADD5	21
STBAVI1255	62	STBXBA2000	47	TSXCANCADD5	21
STBAVI1270	105	STBXBA2000	24	TSXCANCADD5	21
STBAVI1270	62	STBXBA2000	63	TSXCANTDM4	21
STBAVI1275	105	STBXBA2000	75	TSXFPACC12	22
STBAVI1275	62	STBXBA2100	24	TSXFPACC14	22
STBAVO1250	105	STBXBA2200	31	TSXFPACC2	22
STBAVO1250	62	STBXBA2300	24	TSXFPACC4	22
STBAVO1255	105	STBXBA2400	24	TSXFPACC4	22
STBAVO1255	62	STBXBA3000	47	TSXFPACC4	22
STBAVO1265	105	STBXBA3000	72	TSXFPACC4	22
STBAVO1265	62	STBXBA3000	80	TSXFPACC500	22
STBBBS1000	87	STBXBE1000	105	TSXFPACC500	22
STBBBS1003	87	STBXBE1000	24	TSXFPACC500	22
STBBBS1010	87	STBXBE1200	24	TSXIBSCA100	23
STBBBS1011	87	STBXBE2100	105	TSXIBSCA100	23
STBBBS1100	87	STBXBE2100	24	TSXIBSCA400	23
STBCPS2111	24	STBXCA1001	24	TSXPBSCA100	23
STBD AI 5260	105	STBXCA1002	24	TSXPBSCA400	23
STBD AI 5230	105	STBXCA1003	24	XBTXTS1180	47
STBD AI 5230	46	STBXCA1004	24	XBTZ988	91
STBD AI 5260	46	STBXCA1006	24	XBTZ988	91
STBD AI 7220	46	STBXCA3002	75	XBTZ988	91
STBDAO5260	105	STBXCA3003	75		
STBDAO5260	46	STBXCA4002	20		
STBDAO8210	105	STBXCA4002	87		
STBDAO8210	46	STBXCA4002	91		

The efficiency of Telemecanique® branded *solutions*

Used in combination, Telemecanique products provide quality solutions, meeting all your **Automation & Control** applications requirements.



A **worldwide** presence

Constantly available

- More than 5 000 points of sale in 130 countries.
- You can be sure to find the range of products that are right for you and which complies fully with the standards in the country where they are used.

Technical assistance wherever you are

- Our technicians are at your disposal to assist you in finding the optimum solution for your particular needs.
- Schneider Electric provides you with all necessary technical assistance, throughout the world.



Schneider Electric Industries

Head Office
1415 Roselle Road
Palatine, IL 60067
USA
TEL: 847-397-2600
www.schneider-electric.com
www.us.telemecanique.com

Due to evolution of standards and equipment, the characteristics indicated in texts and images of this document do not constitute a commitment on our part without confirmation.

Design: Schneider Electric
Photos: Schneider Electric
Printed by: Delzer Lithograph

Simply Smart !

MKTED206061EN-US