

**OMRON**

# ***V600-Series RFID System Applications***

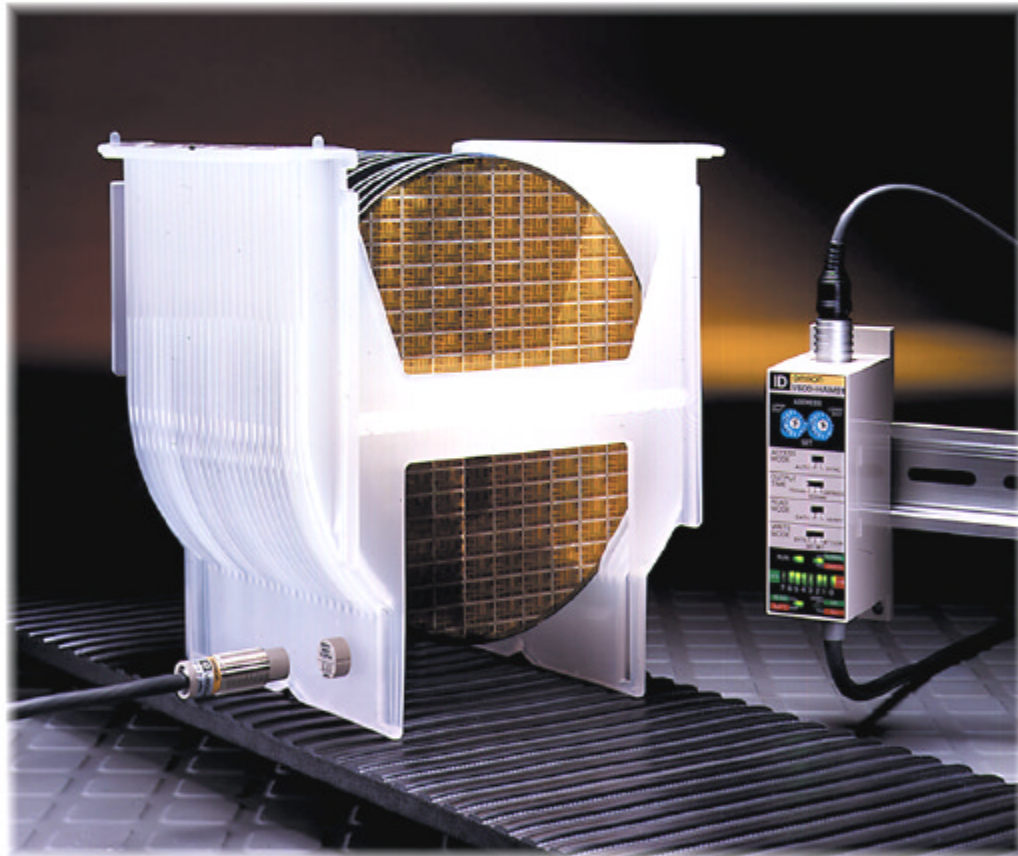

# Is there room for improvement in your organization?

There are various on-site problems awaiting solutions, such as improvement in work efficiency, product quality, and systems for the limited production of a wide variety of goods. The ID System solves all these problems.

## Solutions with the Intelligent Flag Series

### On-site Problem 1

On a production site that uses mechanical flags for discriminating product types, an increase in the number of product types requires additional mechanical flags, sensors, and sensor adjustments, all of which involve time and costs.



### Solution 1

Use the Intelligent Flag, which does not require additional sensors or sensor adjustments, for an increase in the number of product types. Without additional time or costs, the on-site production system can be flexibly adjusted for the limited production of a wide variety of goods by rewriting the data of the Intelligent Flag.



### On-site Problem 2

On a production site that uses a bar-code system, mistakes in bar-code reading occasionally occur when the bar-code readers become dusty. In this case an environment-resistive system is required.



### Solution 2

Use the Intelligent Flag, which uses an inductive-coupling method ensuring precise data communications without being affected by on-site dust, powder, or soil, thus making it possible to construct an optimum, environment-resistive system according to the on-site requirements.

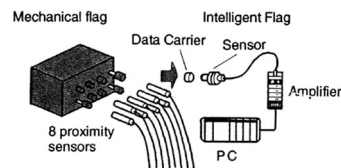

## Solutions with the ID System

### On-site Problem 5

On a production site that uses computers and Programmable Controllers (PLCs), changing computer and PLC programs is quite time-consuming when changing the product type.



### Solution 5

Use the ID System, in which on-site workers just need to rewrite the instruction data of each line in the Data Carrier when changing the product type.

### On-site Problem 6

On a production site that uses a host computer, the host computer has all the work instruction data and each line receives work instructions from the host computer and responds to the host computer. These operations increase the load of the host computer.



### Solution 6

Use the ID System, which is a stand-alone system that does not require any network communications with the host computer in any lines other than the final production line. Each of the lines reads the necessary work instructions from the Data Carrier directly and there is no need to respond to the host computer. Therefore, the system reduces the load of the host computer.

### On-site Problem 3

On a production site that uses mechanical flags, the limited on-site space is a serious problem because the sensing distance of each sensor is fixed.



### Solution 3

Use the Intelligent Flag, which has a wide range of communications distances up to 65 mm. Unlike conventional sensors, the Intelligent Flag does not require precise positioning. Furthermore, by using the Intelligent Flag, on-site workers are not bothered by the mutual interference caused by adjacent sensors.

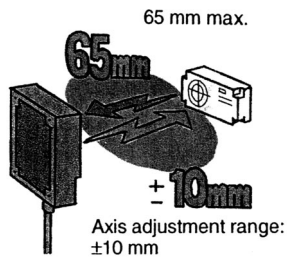

### On-site Problem 4

On a production site that manufactures products with low unit prices, there is a demand for the construction of high-degree lines with minimum investment.



### Solution 4

Use the Intelligent Flag, which makes it possible for the Data Carrier to perform 256 types of discrimination. On the other hand, a conventional mechanical flag system requires a number of mechanical flags corresponding to the number of product types.

	Number of flags	Number of sensors
Mechanical flag	256	8
↓	↓	↓
Intelligent Flag	1	1

## The OMRON ID System Helps Solve Your On-site Problems

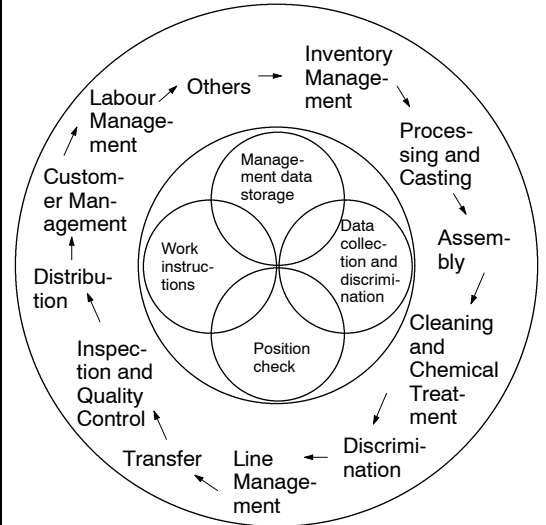

OMRON offers solutions to on-site problems from four viewpoints as shown in the above illustration, thus contributing to solving a variety of industrial problems, including the problems at your site.

### On-site Problem 7

On a production site that uses a host computer, the expansion of the system requires additional networks and program changes, thus necessitating the redesigning of the whole system.



### Solution 7

Use the ID System, which makes it possible to easily expand the system by just installing the Data Carrier and sensor in distributed control. For example, an inspection line can be easily added without changing the whole system.



## Inventory Management

### Inventory Management of an Automatic Warehouse

V600-D23P71 Data Carrier  
V600-H11 R/W Head (Sensor)  
V600-CD1D-V3 ID Controller

- **Problem**

There is a bar-code or mechanical flag system which requires the construction of a network to connect to another system, such as a picking or assortment system. This will, however, make the whole system complicated.

- **Solution**

Attach the Data Carrier to each pallet for inventory management.

- **Advantage**

Each pallet has data corresponding to the pallet, thus making it possible to construct the system with ease.

In the case of a fixed location, the system can be controlled with the personal computer alone by using information on incoming goods to be input into the Data Carrier.

The automatic warehouse system can be started up with ease with these Units.

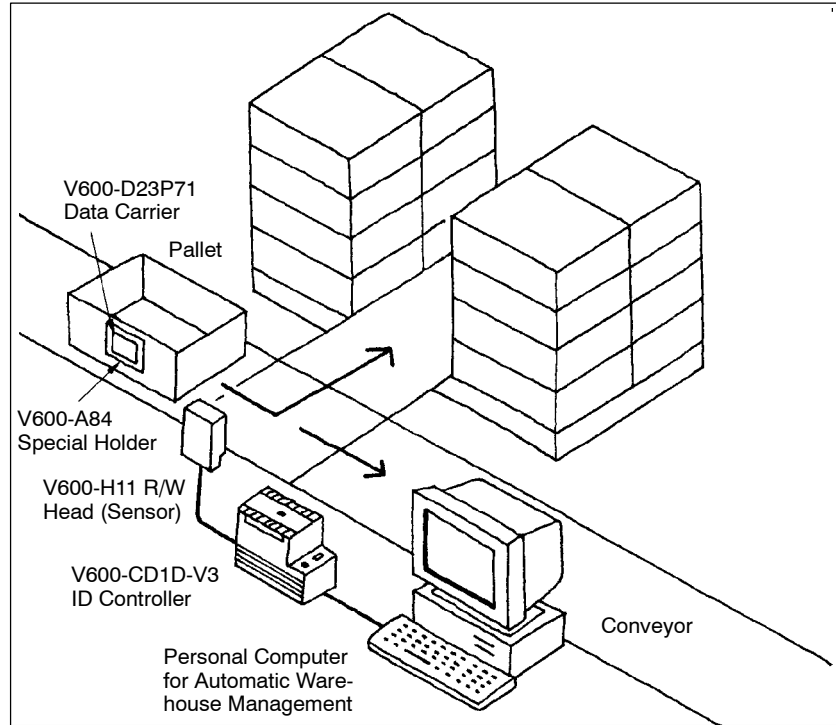

## Inventory Management

### Picking Instructions

V600-D23P71 Data Carrier  
V600-H11 R/W Head (Sensor)  
C200H-IDS01-V1 ID Controller

- **Problem**

There is a production site where picking work is performed according to the information on paper slips, which can cause careless mistakes and clerical errors.

Picking work with paper slips is inefficient.

- **Solution**

Attach the Data Carrier to each pallet and install the sensor to the picking station for automatic data reading.

- **Advantage**

With the arrival of the pallet, the picking shelf displays the picking instructions, thus ensuring efficient and accurate picking work.

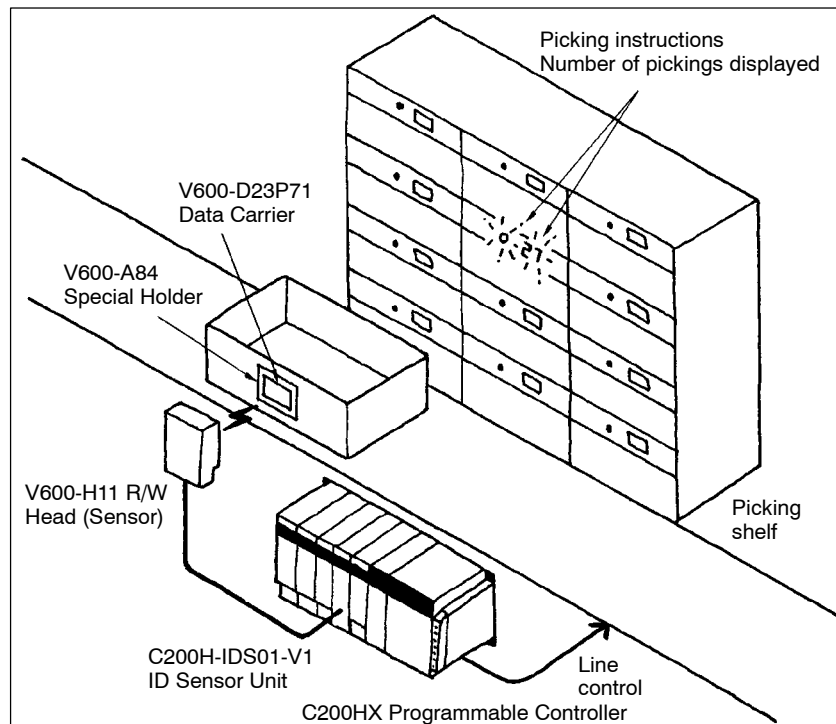

## Inventory Management

### Warehouse Inventory Management

V600-D23P71 Data Carrier  
V600-CH1D-C Handheld Reader Writer

- **Problem**

There is a production site where warehouse inventory management is done with written records, which can cause careless mistakes and clerical errors.

Manual inventory work is time-consuming and inefficient.

- **Solution**

Weld the Special Holder to each pallet so that the card-type Data Carrier can be attached to the Special Holder.

Write information on the components on the pallet to the Data Carrier, such as the component number, type, and quantity.

Use the Handheld Reader Writer to read the information in the Data Carrier on each pallet and transfer the information to the on-site personal computer.

- **Advantage**

Inventory management is possible by just reading the information in the Data Carrier, which makes efficient inventory work possible.

The information in the Handheld Reader Writer can be transferred the personal computer with ease, and the information can be processed and converted into tables and graphs.



## Processing/Casting

### Tool Inventory Management at a Machining Site

V600-D23P53/54 Data Carrier  
V600-HS51/V600-HS61 R/W Head (Sensor)  
V600-HA51 R/W Head (Amplifier)  
V600-CA1A-F-V2 ID Controller (Conforming to FANUC Protocol)

- **Problem**

There is a machining site where the inventory management of tools with tool number, size, and operating time data is performed with paper records, which can cause careless input and handling mistakes.

It is time-consuming to find tools without managed information on the whereabouts of the tools.

- **Solution**

Write information on each tool measured with the tool presetting device to the Data Carrier attached to the tool.

Read the information from the Data Carrier with the Position Control Unit of the on-site machining system.

- **Advantage**

Information on each tool is recorded individually, which increases the efficiency of inventory management and reduces careless mistakes and clerical errors.

The Data Carrier is attached to the pull-stud or drive-key groove of each tool.

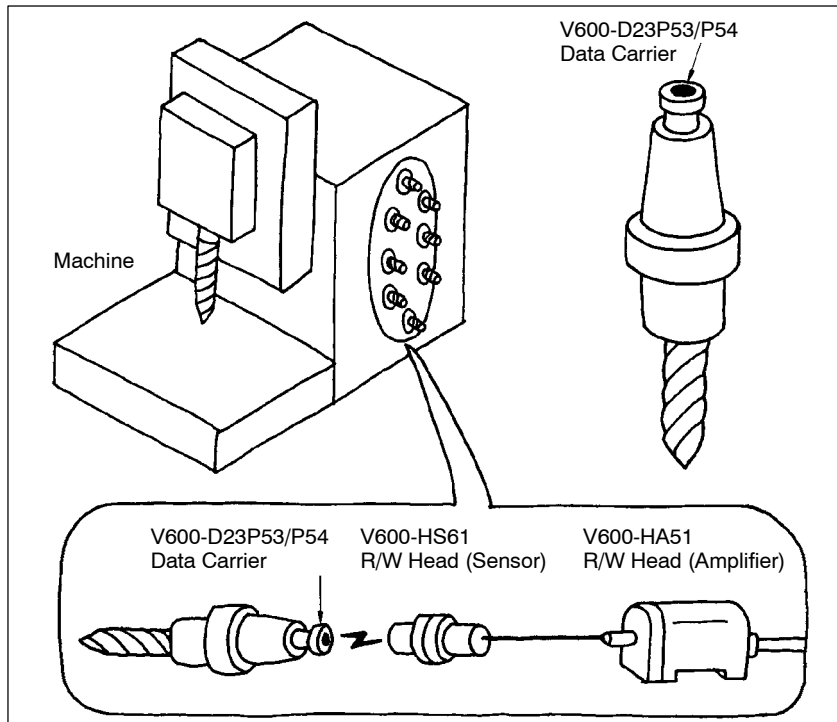

## Processing and Casting

### Metal Mold Management

V600-D23-P66 Data Carrier  
V600-H11 R/W Head (Sensor)  
V600-CA1A-V2 ID Controller

#### • Problem

There is a system that has a molding machine, mold exchanger handling a variety of molds, and a host computer which requires the operation of the system without step-by-step communications with the host computer.

#### • Solution

Attach to each mold the Data Carrier that has information on molding conditions corresponding to the mold, such as mold number, molding temperature, cylinder temperature, injection time, and injection speed data.

#### • Advantage

The burden on the communications software running in the host computer and the frequency of communications can be reduced.

The wrong mold is checked and rejected automatically, which eliminates the manufacturing of improper products.

The V600-D23P66 Data Carrier can withstand a temperature of 110°C and read and write data within a temperature range from -20°C to 70°C.

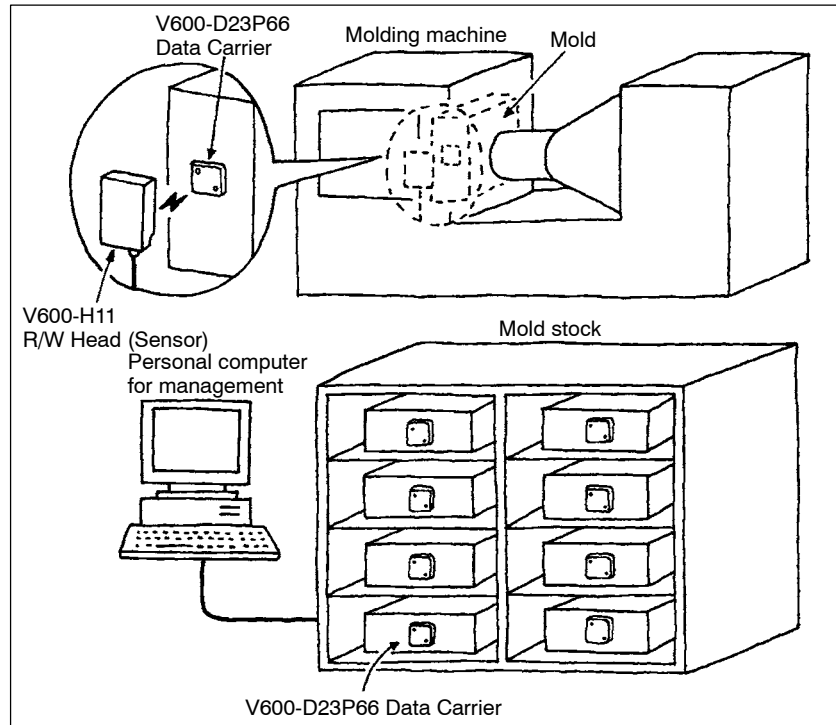

## Processing and Casting

### Press Mold Management

V600-D23P53/54 Data Carrier  
V600-HA51/-HS61 R/W Head (Sensor)  
C200H-IDS01-V1 ID Controller

#### • Problem

Press mold management with paper records can cause careless setting mistakes.

#### • Solution

From the Data Carrier attached to the press mold on the pressing machine, information on the press mold number, stroke length, and total number of shots is read. At the time of press mold change, the present number of shots is overwritten to the Data Carrier.

#### • Advantage

Use a personal computer to manage the location of each press mold and read the number of the press mold shots to manage the life of the press mold.

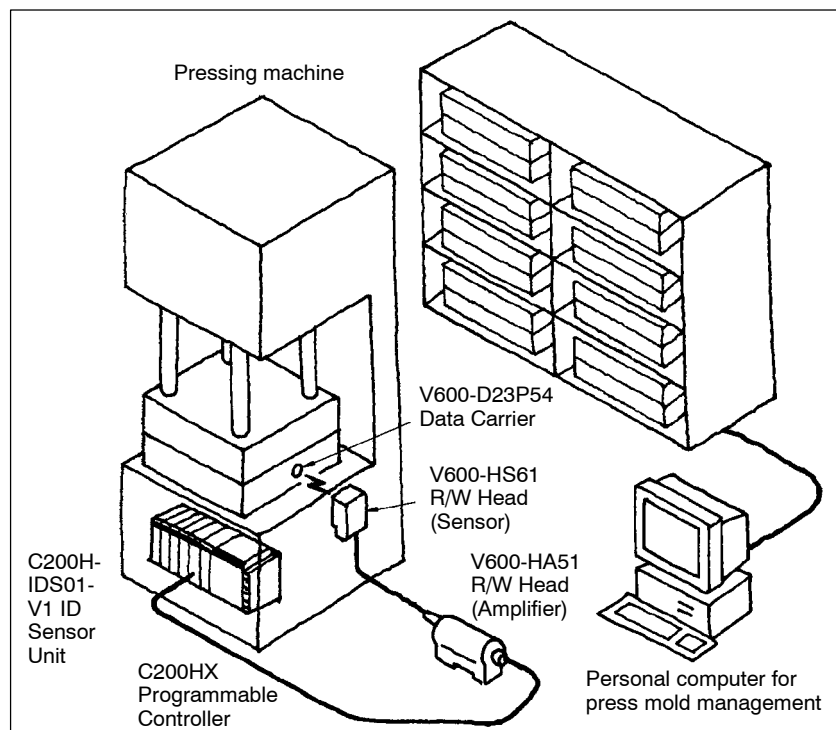

## Processing and Casting

### Automatic Casting Material Supply in a Casting Line

V600-D8KR12 Data Carrier  
V600-H07 R/W Head (Sensor)  
C200H-IDS01-V1 ID Controller

#### • Problem

There is a production site that has a casting line supplying materials to each casting mold according to the identification number on the casting mold. The line often has mistakes in identification due to factors peculiar to this dirty, dangerous, and difficult site, such as dust, temperature, vibration, and shock.

#### • Solution

Attach to each casting mold the Data Carrier that has information on the casting mold number and material supply position to be read for the automatization of the supply of materials.

#### • Advantage

Casting mold numbers are read correctly.

The Data Carrier holds information on the mold material supply position even if the power supply fails, thus starting the system automatically after power is turned on.

The reliability of data communications is not lowered by dust or dirt.

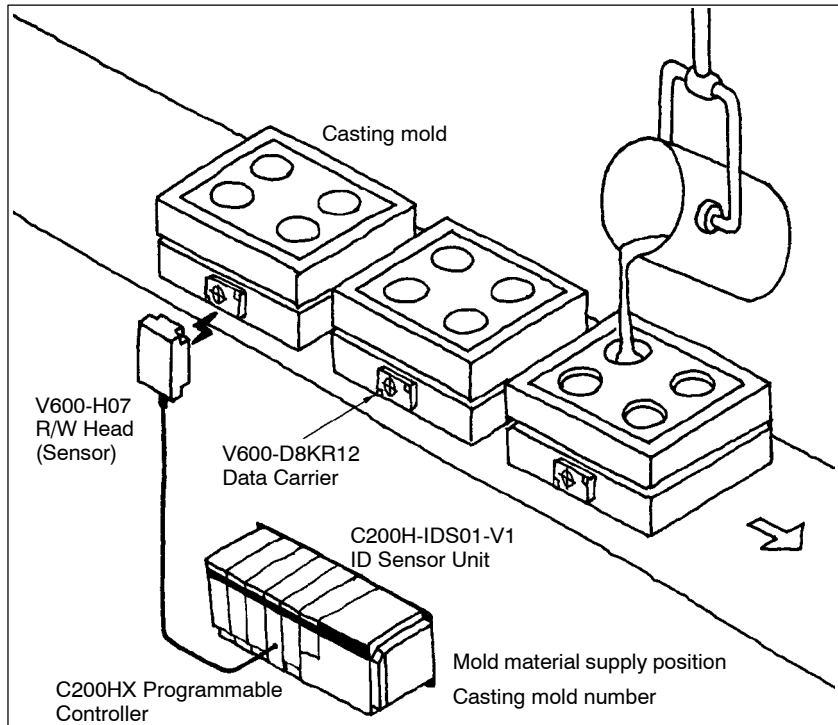

## Assembly

### Component Discrimination in an Automobile Assembly Line

V600-D8KR12 Data Carrier  
V600-HS63 R/W Head (Sensor)  
V600-HAR91 Read-only Amplifier (Intelligent Flag)

#### • Problem

There is an automobile production site that has an assembly line where mechanical flags are reluctantly applied, because workpiece discrimination data consists of 4 to 8 bits and the use of the ID system costs too much.

#### • Solution

The Intelligent Flag can use the conventional Data Carrier, thus changing the system into an optimum, low-cost system.

#### • Advantage

Unlike mechanical flags, an increase in the number of component types does not require modification to the Intelligent Flag system. Furthermore, compared with mechanical flags, precise positioning is not required.

It is possible to construct an optimum system with minimal investment.

The conventional V600-series Data Carrier can be used, thus upgrading all or part of the system flexibly.

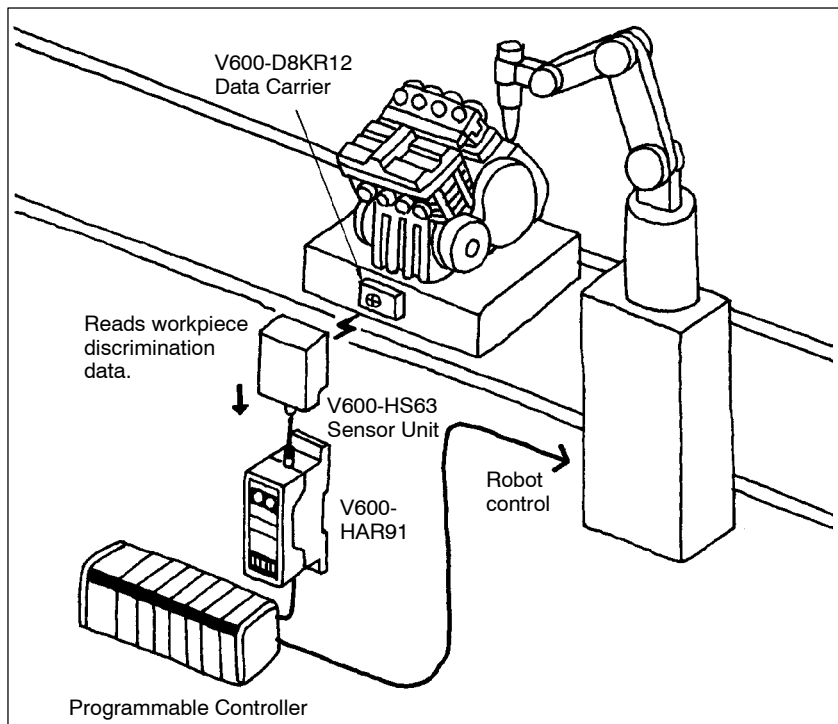

## Assembly

# Assembly Instructions in an Automobile Body Assembly Line

V620-D8KR01 Data Carrier  
V620-H02 R/W Antenna  
C200H-IDS21 ID Controller

### • Problem

There is a production site that has an automobile body welding line where work management is performed with paper records, which often causes careless mistakes and clerical errors.

The use of a mechanical flag or bar-code system in the line allows management of information by the lot only, thus increasing the load of the host computer.

### • Solution

By attaching to each automobile body the Data Carrier that has information on work instructions, such as spot-point data, it is possible to construct a stand-alone station that does not impose excessive loads on the host computer.

Work instructions are given without paper, thus preventing careless mistakes and clerical errors.

### • Advantage

The environment-resistive ID System will be more effective than the bar-code system if the working environment is tough, because the bar-code system cannot read bar codes if the bar codes are dirty due to dust or other factors.

By using the ID Sensor Unit, which connects the R/W Antenna to the Programmable Controller directly, a more efficient system can be constructed.

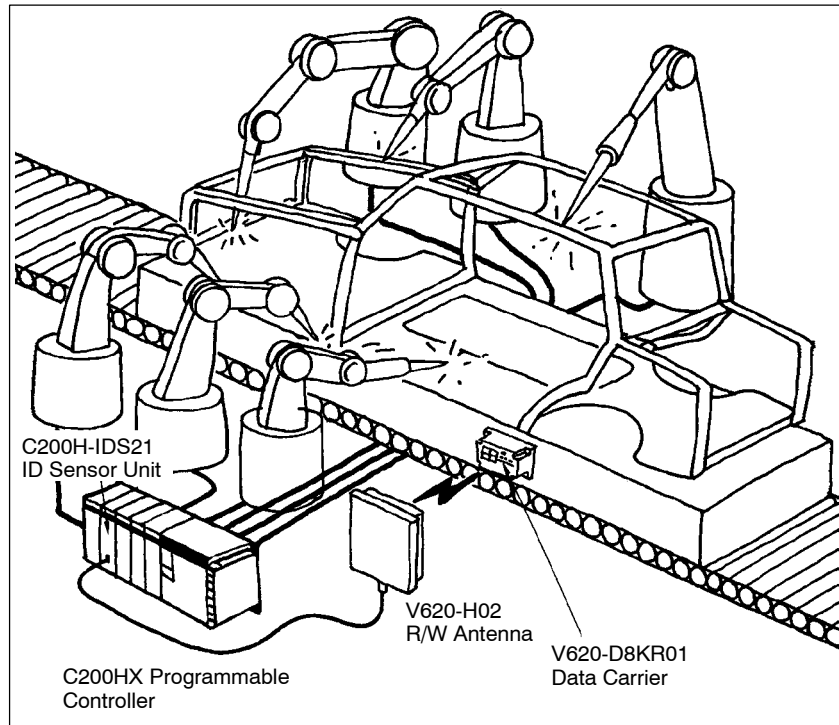

## Assembly

# Line and Distribution Management at a TV Production Site

V630-D4KR11 Data Carrier  
V630-H12 R/W Head

### • Problem

There is a TV production site which requires the monitoring of the progress of product assembly in each line.

Sudden line rearrangements due to product changes are time-consuming because the lines are in tracking control.

### • Solution

By attaching to each product the Data Carrier that has product number, model number, processing, and assembly data, each line operates smoothly according to the information in the Data Carrier.

### • Advantage

Information on product inspection results is written to the Data Carrier in the on-site inspection line. The information is read, and the product is packed if the information satisfies product standards, and the product is transferred to the on-site distribution line.

Each product is classified efficiently according to the size and destination by referring to the initial information written to the Data Carrier.

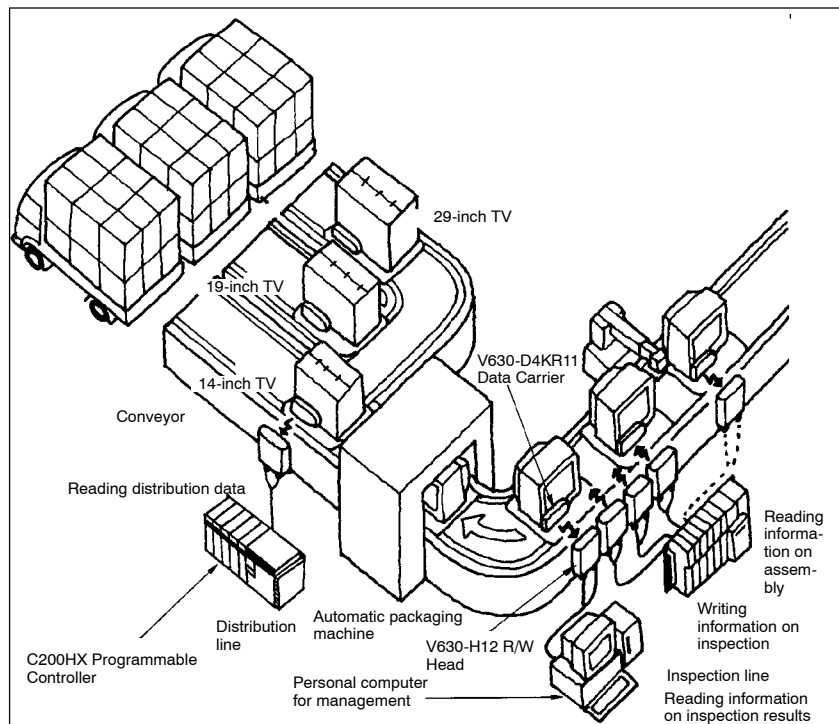



## Assembly

# PCB (Printed Circuit Board) Magazine Management

V600-D23P71 Data Carrier  
V600-H07 R/W Head (Sensor)  
V600-CA1A-V2 ID Controller

### • Problem

There is a production site that has a line where rearrangements of the line are made according to the information on paper slips attached to magazines for PCB use, which often involves careless mistakes and clerical errors and decreasing the line efficiency.

### • Solution

From the Data Carrier attached to the magazine on the loader side of the line, information on line rearrangements is read and instructions are given to the production equipment of the line.

After a set of PCBs is processed, information on the production work is written to the Data Carrier attached to the magazine on the unloading side of the line.

### • Advantage

Both magazines have data corresponding to the products, thus reducing careless mistakes and clerical errors and increasing the line efficiency.

The V600-D23P61 or V600-DKR16 Data Carrier is ideal if metal-made magazines are used.

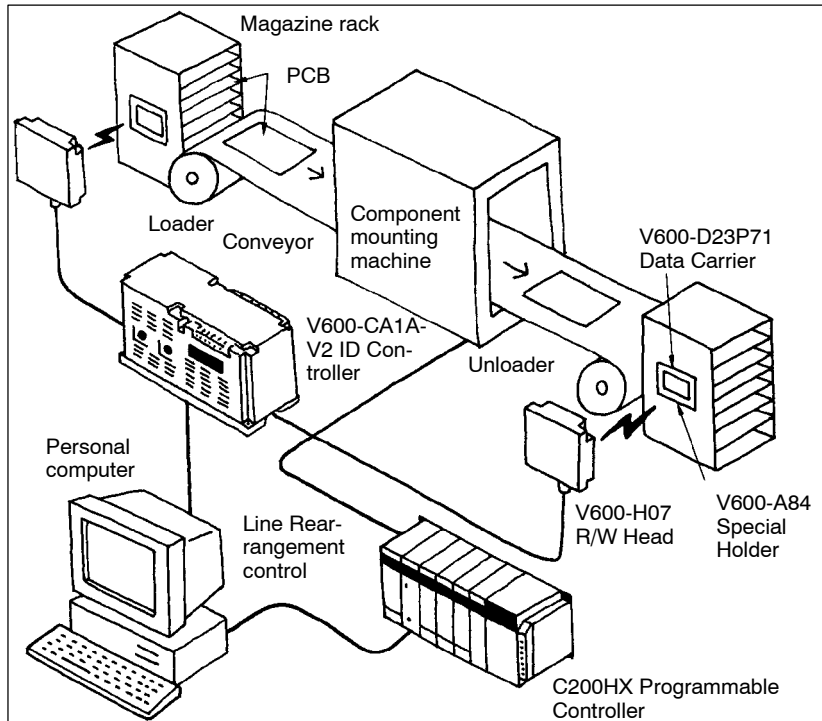

## Assembly

# Product Type Checking in a Semiconductor or LCD Production Line

V600-D23P66SP Data Carrier  
V600-H07 R/W Head (Sensor)  
V600-CH1D-C Handheld Reader Writer

### • Problem

There is a production site that has a line where cassettes are usually conveyed without any problems. However, if line interruptions or problems occurs and some cassettes drop out of the line, it will be necessary to identify the cassettes.

A fixed sensor is difficult to apply to the line.

### • Solution

Use the V600-CH1D-C Handheld Reader Writer in combination with a Handheld Controller so that data can be read and written anywhere.

### • Advantage

The V600-D23P66SP Data Carrier is ideal for the line because this model is of a Teflon (PFA) dual-package construction.

**Note:** Teflon is a registered trademark of the Dupont Corporation and the Mitsui Dupont Chemical Corporation for their fluoride resin.

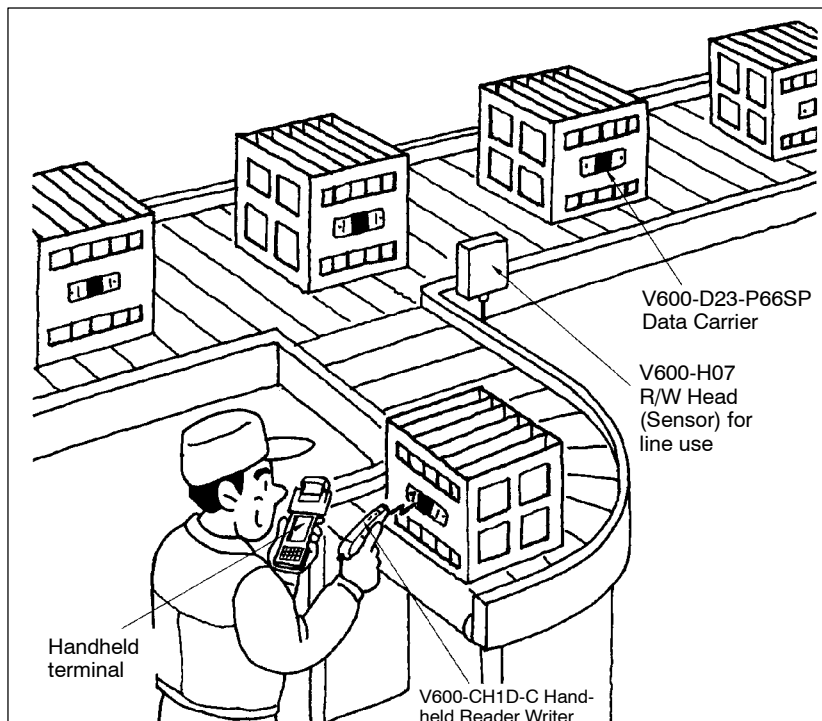

## Assembly

### Product Type Checking with an Electronic Display Panel

#### • Problem

There is a production site where a mechanical flag type display panel is used, which requires precise sensor positioning and which will cause problems if the display panel moves.

An increase in the number of product types requires a new display panel and additional sensors, which involves time and cost.

#### • Solution

Use the 16-bit V600-HAR92 Read-only Amplifier (Intelligent Flag II) which is available for 4-digit alphanumeric display panels.

The number of product types can be increased by rewriting the data of the Intelligent Flag II without requiring additional mechanisms.

#### • Advantage

The Intelligent Flag II has a wide communications area, which makes it possible to read information on product codes and makes it ideal for tact-time reduction.

The Intelligent Flag II uses a radio-transmission method, thus eliminating mechanical problems, such as difficulty in positioning.

V600-D23P66 Data Carrier  
V600-HS63 R/W Head (Sensor)  
V600-HAR92 Read-only Amplifier  
(Intelligent Flag II)

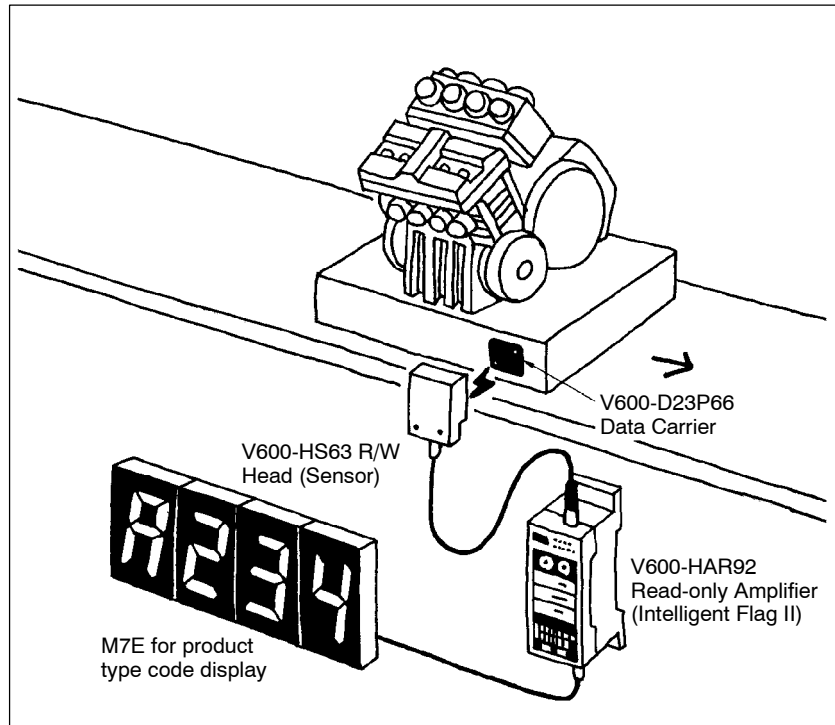

## Cleaning and Chemical Treatment

### Condition Setting in a Plating Line

#### • Problem

There is a production site where each type of component is different in plating pattern and it is time-consuming to change the plating pattern.

#### • Solution

Attach to each basket that carries plating components the Data Carrier that has component and plating pattern data.

#### • Advantage

Each basket has data corresponding to the basket, thus reducing careless mistakes and clerical errors and increasing the efficiency of the line.

The V600-D23P66SP Data Carrier is ideal for the line because this model is highly resistant to chemicals and can be used at a maximum temperature of 110°C.

V600-D23P66SP Data Carrier  
V600-H11 R/W Head (Sensor)

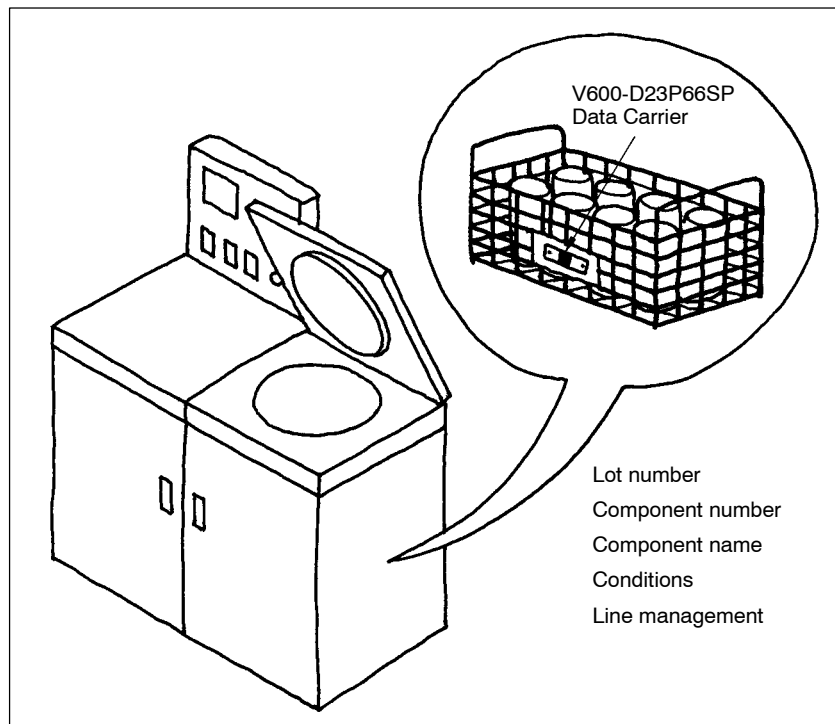

## Cleaning and Chemical Treatment

### Pallet Management in a LCD or Semiconductor Production Line

#### • Problem

There is a production site that has lines different to each other in chemical processing condition and it is time-consuming to change in each line the setting of each pallet that carries components.

There is no conventional ID system that is chemical-resistant.

#### • Solution

Attach to each pallet the chemical-resistant Data Carrier that has component and production data.

#### • Advantage

The V600-D23P66SP Data Carrier is ideal for the line because this model is of a Teflon (PFA) dual-package construction, highly resistant to chemicals, and available for IPA and fluorine acid use or other chemical cleaning.

Each pallet has data corresponding to the pallet, thus reducing careless mistakes and clerical errors and increasing the line efficiency.

The V600-D23P66, V600-D23P61, and other Data Carriers can be used, depending on the type of pallet and line.

**Note:** Teflon is a registered trademark of the Dupont Corporation and the Mitsui Dupont Chemical Corporation for their fluoride resin.

V600-D23P66SP Data Carrier  
V600-H11 R/W Head (Sensor)

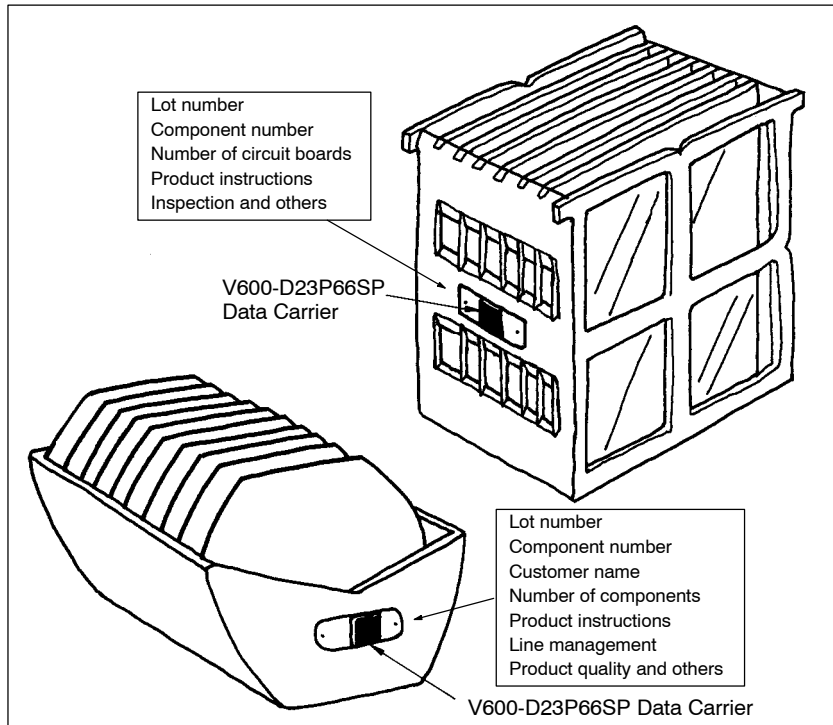

## Cleaning and Chemical Treatment

### PCB (Printed Circuit Board) Management in an Etching Line

#### • Problem

There is a production site where chemicals are used for a PCB etching line, thus making PCB management with standard bar-code stickers difficult.

There is a need for the discrimination of PCB types, the management of the line record, and the control of PCB quality.

#### • Solution

Attach to each cassette that carries PCBs the chemical-resistant Data Carrier of a Teflon (PFA) dual-package construction that has information on lot number, product number, etching date, line management, and PCB quantity data. This will make line management and PCB quality control possible.

#### • Advantage

The V600-D23P66SP Data Carrier is ideal for the line because this model is of a Teflon (PFA) dual-package construction and highly resistant to chemicals.

All product information is given without paper, thus eliminating rubbish and improving the quality of PCBs.

**Note:** Teflon is a registered trademark of the Dupont Company and the Mitsui Dupont Chemical Company for their fluoride resin.

V600-D23P66SP Data Carrier  
V600-H11 R/W Head (Sensor)

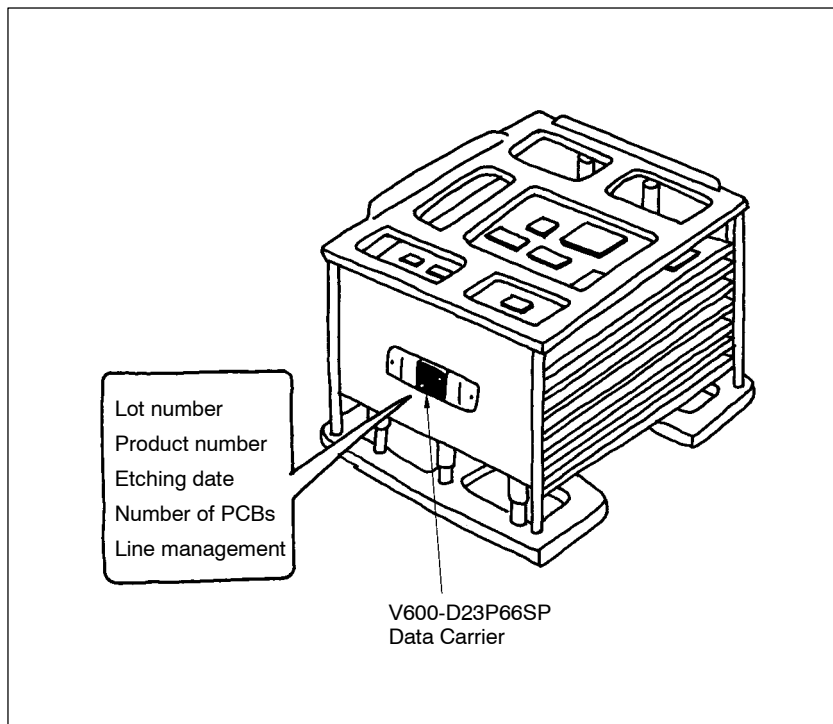

## Cleaning and Chemical Treatment

### Food Container Management in a Cleaning Line

V600-D23P66SP Data Carrier  
V600-H07/-H11 R/W Head (Sensor)

#### • Problem

A food container is usually washed with hydrogen peroxide solution, detergent, or water. The standard Data Carrier, which is not chemical or heat-resistant, cannot be attached to the food container.

The Data Carrier attached to the food container may propagate microorganisms.

#### • Solution

Attach the chemical-resistant Data Carrier of a Teflon (PFA) dual-package construction to the food container so that the food container and Data Carrier can be washed with chemicals.

Teflon is highly anti-cohesive and suppresses the propagation of microorganisms.

#### • Advantage

The V600-D23P66SP Data Carrier is ideal for the line because this model is of a Teflon (PFA) dual-package construction, highly resistant to chemicals, and ideal for suppressing the propagation of microorganisms.

The V600-D23P66SP Data Carrier can be boiled with water because it withstands a maximum temperature of 110°C.

**Note:** Teflon is a registered trademark of the Dupont Company and the Mitsui Dupont Chemical Company for their fluoride resin.

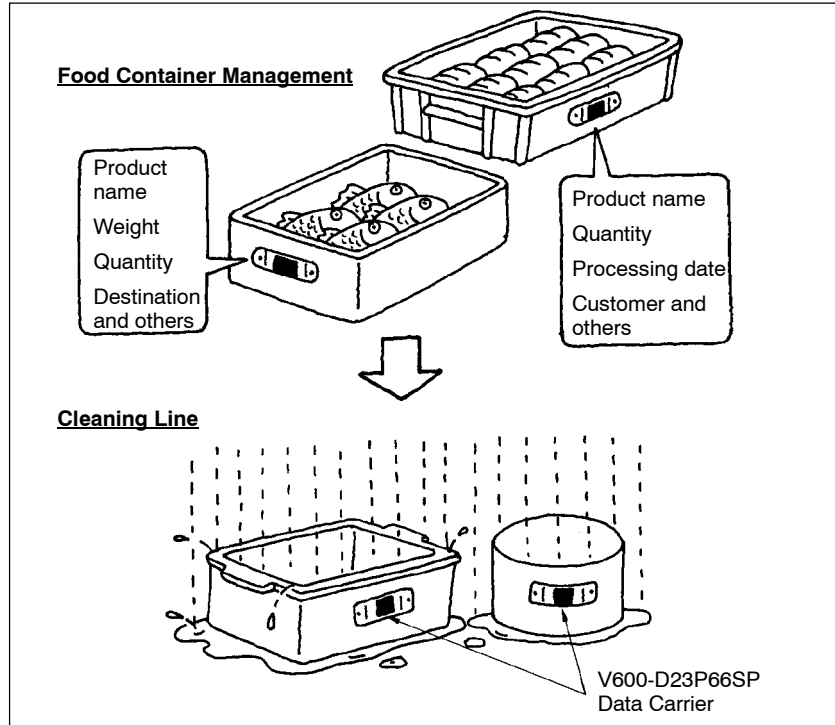

## Discrimination

### Product Discrimination in a TV Assembly Line

V600-D23P66 Data Carrier  
V600-HS63 R/W Head (Sensor)  
V600-HAR91 Read-only Amplifier  
(Intelligent Flag)

#### • Problem

There is a TV production site where the cost of product discrimination is a serious problem. Presently, it costs nearly \$800 to manufacture a single mechanical flag and the site requires 15 mechanical flags, which costs a total of \$12,000.

#### • Solution

Use the Intelligent Flag so that the production cost (\$12,000) will be reduced to \$5,500 (a standard cost).

#### • Advantage

It is possible to eliminate the costs presently required for the design and production of the mechanical flags.

The discrimination system using the Intelligent Flag eliminates all mechanical elements, thus reducing line problems.

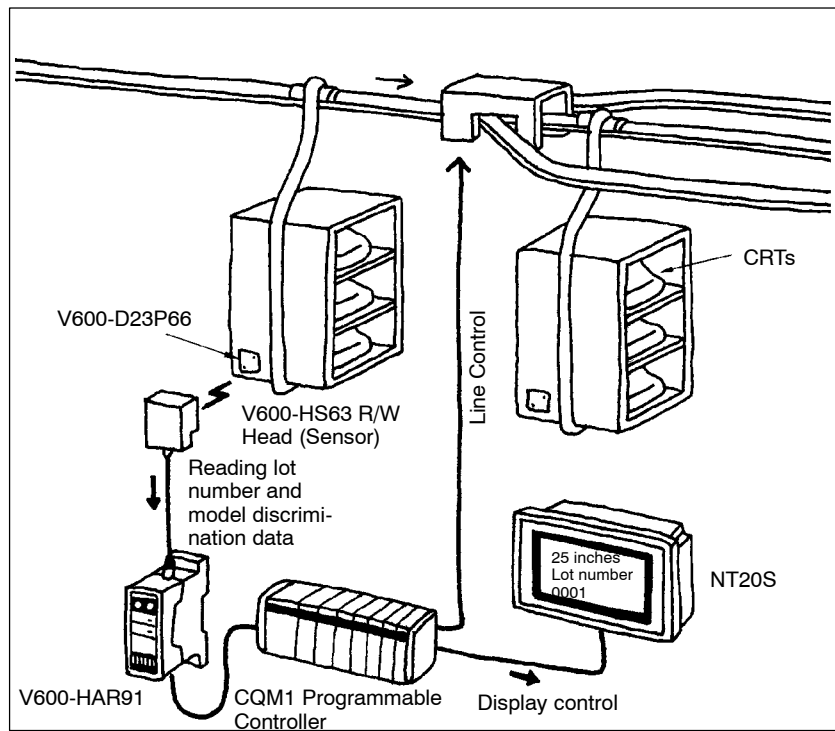

## Discrimination

### Discrimination of Tire Types and Destinations

V600-D8KR04 Data Carrier  
V600-H07 R/W Head (Sensor)  
V600-CA9A-V2 ID Controller

- **Problem**

There is a production site with a need for the automatic discrimination of tires after they are taken out of the molding machine on the site and hooked on hangers.

- **Solution**

Attach to each hanger the Data Carrier that has the tire type and order specification data to be read in the distribution and other lines.

The Data Carrier is attached to the hanger directly, thus making it possible to keep up with sudden line rearrangements.

- **Advantage**

All hangers can be the same size. Conventionally, the hanger size varies with the tire size.

There is no need to find hangers according to the tire size, which reduces on-site waiting time and increases the efficiency of production.

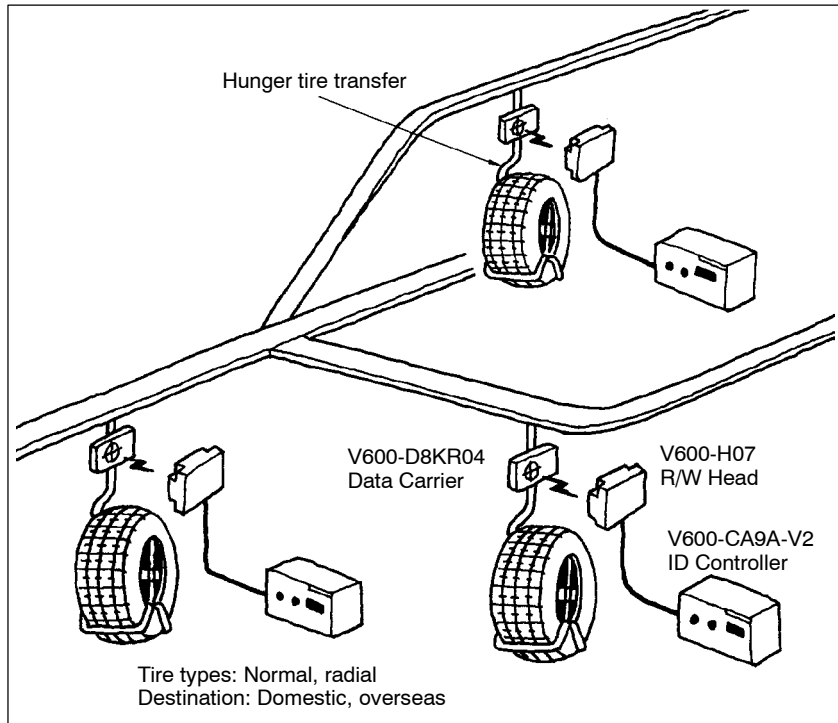

## Discrimination

### Product Discrimination in a Suit Production Line

V600-D23P71 Data Carrier  
V600-HS63 R/W Head (Sensor)  
V600-HAR91 Read-only Amplifier (Intelligent Flag)

- **Problem**

There is a suit production site where mechanical flags often malfunction.

The bar-code system cannot be used due to a cost problem.

- **Solution**

Use the Intelligent Flag, which replaces the mechanical flags and provides an ideal system at low cost.

- **Advantage**

The Intelligent Flag can be used with minor modifications to the existing system, thus making it possible to improve the system with minimal investment.

The Intelligent Flag uses a radio-transmission method, thus eliminating mechanical problems, such as difficulty in positioning.

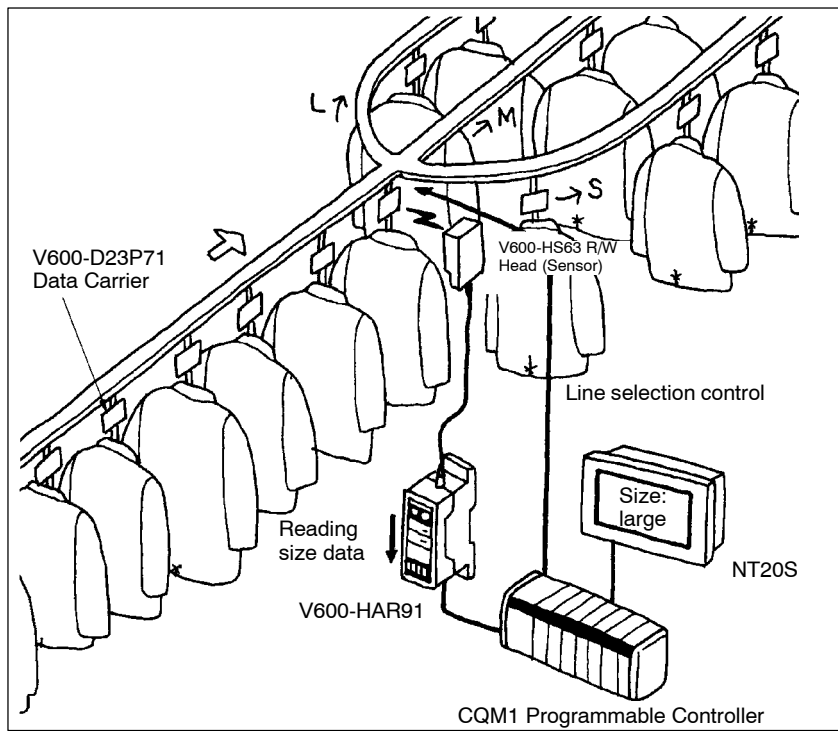

## Discrimination

### Produce Discrimination in a Fruit and Vegetable Selection Line

#### • Problem

There is a fruit and vegetable selection line where fruit and vegetables are discriminated with mechanical flags, which is costly and often cause problems.

An increase in the number of produce types requires the upgrade of mechanical flags, which involves time and cost.

#### • Solution

Use the Intelligent Flag, which makes it possible for the Data Carrier to perform 256 types of discrimination according to the size and grade together.

#### • Advantage

The Intelligent Flag makes it possible for the Data Carrier to perform 256 types of discrimination. Furthermore, it is possible to greatly reduce the present flag cost.

The Data Carrier can read and write data while it is moving, thus smoothing the distribution work in the line.

The system is environment-resistive like proximity sensors and highly resistant to dust.

V600-D23P66 Data Carrier  
V600-HS63 R/W Head (Sensor)  
V600-HAR91 Read-only Amplifier  
(Intelligent Flag)

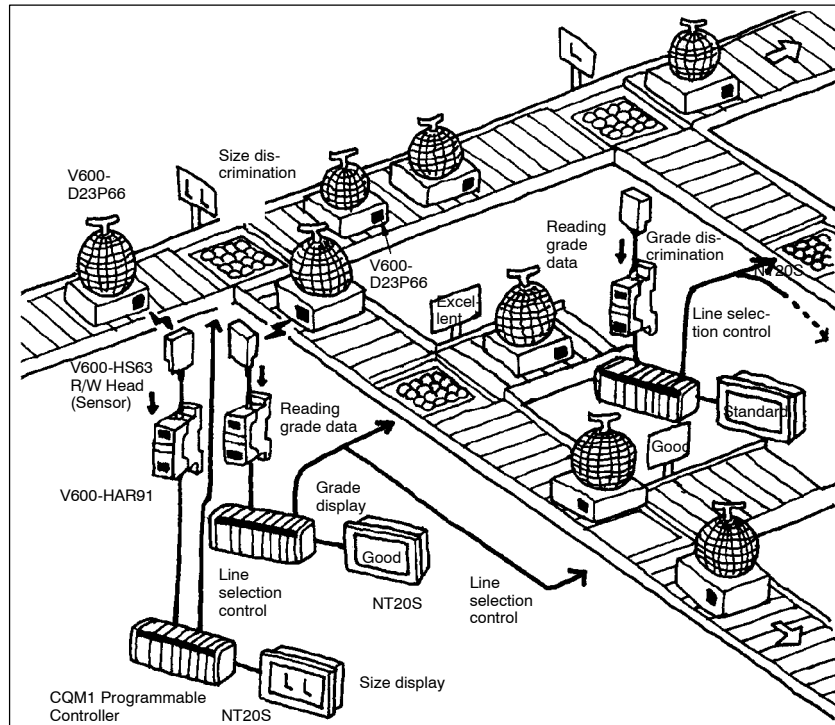

## Discrimination

### Automobile Discrimination in an Inspection Line

#### • Problem

There is a production site with a need for the automatic and efficient discrimination of finished automobiles to be distributed to corresponding inspection lines.

#### • Solution

Use the V620-series Data Carrier, which ensures the microwave data transmission for 2 m for line selection.

The Data Carrier has a capacity of 8 Kbytes for storing inspection results.

#### • Advantage

This system is a long-distance (2 m) ID System which communicates with the Data Carrier attached to the body of each automobile.

V600-D8KR01 Data Carrier  
V620-H01 R/W Antenna  
C200H-IDS21 Controller

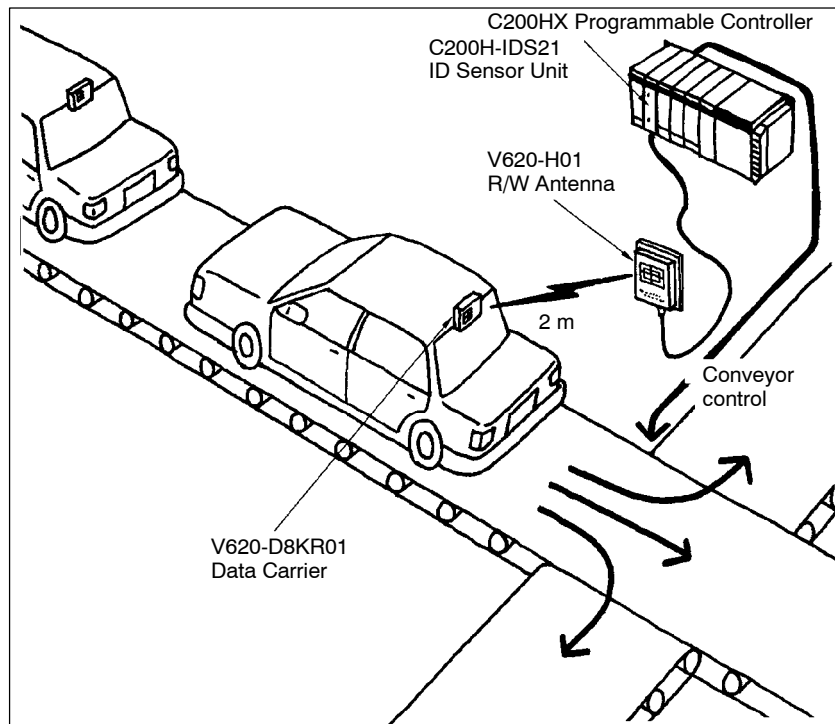

## Discrimination

### Discrimination of Various Products with Units Saving Wiring Effort

V600-D23P71 Data Carrier  
V600-HS63 R/W Head (Sensor)  
V600-HAR92 Read-only Amplifier  
(Intelligent Flag II)

#### • Problem

There is a production site with a need for an economical method to discriminate a wide variety of products because mechanical flags often have mechanical problems and an increase in the number of product types requires additional mechanical flags and sensors.

The Intelligent Flag can handle 256 types of discrimination. If more types need to be discriminated, the Intelligent Flag will not be capable of handling this.

#### • Solution

Use the 16-bit Intelligent Flag II, which makes it possible to discriminate a maximum of approximately 64,000 product types and eliminates all mechanical problems.

The Intelligent Flag II in wiring-saving mode connects to 16-point devices thus saving wiring effort and making serial host communications possible.

#### • Advantage

The Intelligent Flag II uses a radio-transmission method, thus eliminating mechanical problems.

The saving-wiring mode makes it possible to simplify on-site wiring.

Furthermore, the Intelligent Flag II has parity-check output that makes it possible to detect line disconnection.

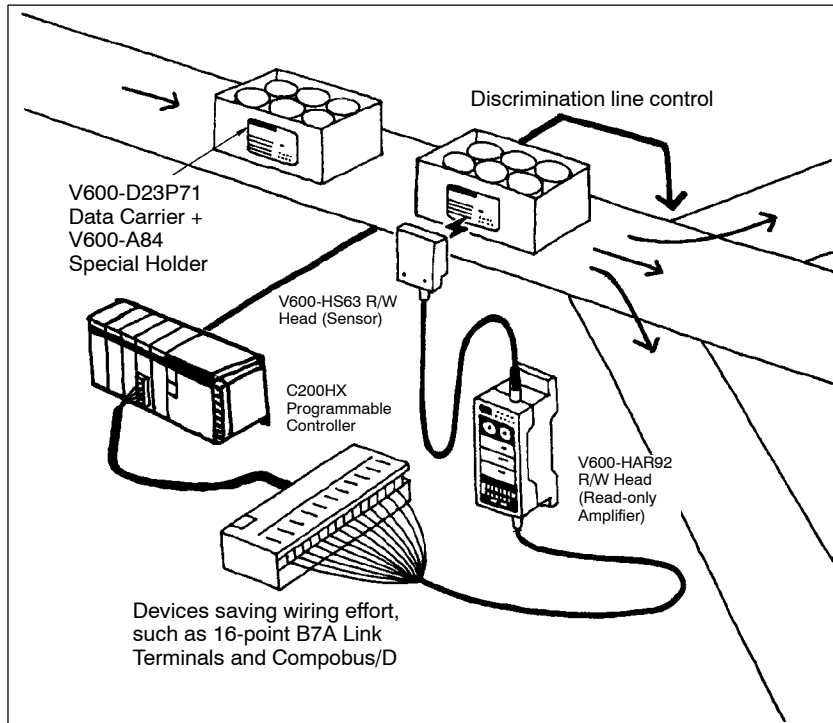

## Line Management

### Progress Management in Production Line

V600-D23P61 Data Carrier  
V600-HS63 R/W Head (Sensor)  
V600-HAM91 Intelligent Flag II

#### • Problem

There is a production site with a line where the environment-resistive Data Carrier is required.

There is a need for the simplification of the line so that the line can easily make changes to handle a variety of products.

#### • Solution

Apply the Data Carrier, from which information on product code and Work Completion Flag data are read to complete the work on each line, and turn ON the Work Completion Flag.

#### • Advantage

The V600-HAM91 system makes it possible to rewrite bit data so that each of the 8 bits will independently have a unique meaning.

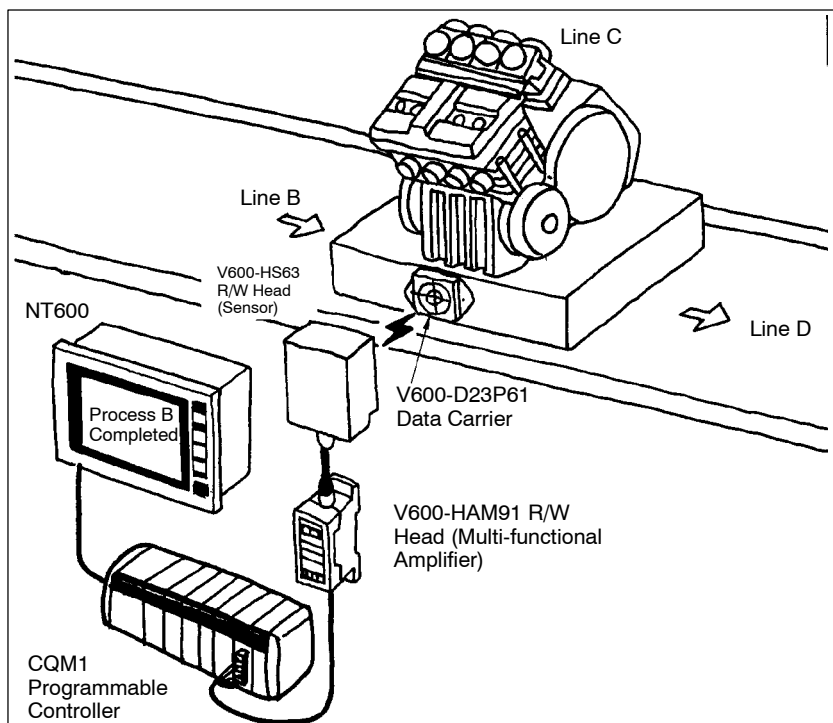

## Line Management

# Operation Control of a Material Transportation System

V600-D8KR04 Data Carrier  
V600-H07 R/W Head (Sensor)  
C500-IDS01-V2 ID Controller

### • Problem

There is a production site with a host computer where transportation carts are in tracking control with the host computer, which is making the system including the hardware complicated and making it difficult to restore tracking mistakes.

Each cart incurs a great loss of waiting time because the cart cannot be in standby control.

### • Solution

Attach to each cart the Data Carrier that has work instruction and destination data for smooth transportation control.

### • Advantage

The system reduces the volume of the tracking program and prevents tracking mistakes.

Each cart has data corresponding to the cart, thus making it possible to change the cart order smoothly, operate the system efficiently according to the progress of production, and restart the system with ease after power failures.

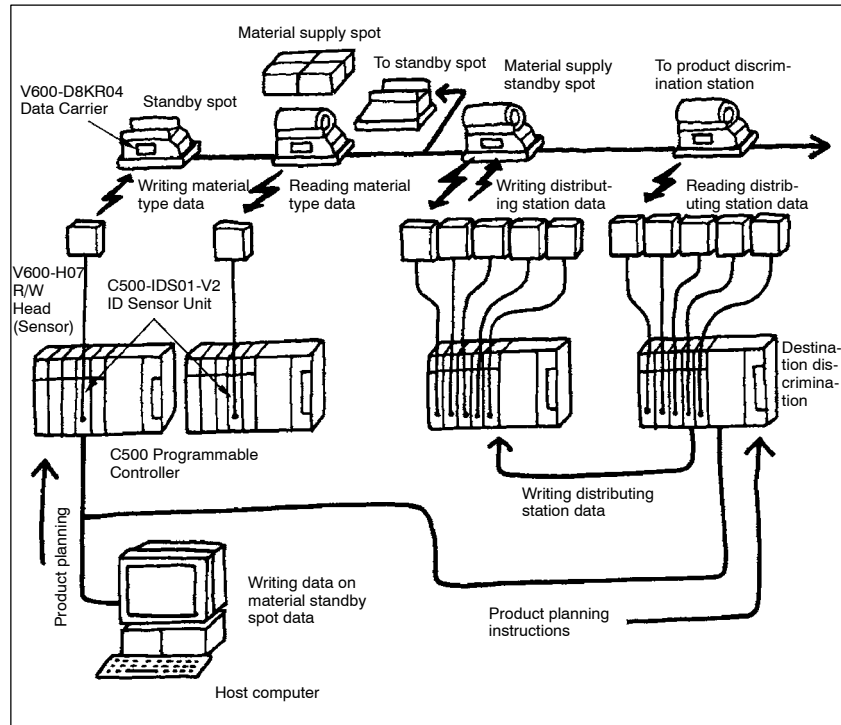

## Line Management

# Increase in the Efficiency of Automatic Machines

V600-D8KR04 Data Carrier  
V600-H07 R/W Head (Sensor)  
C500-IDS01-V2 ID Controller

### • Problem

There is a production site that has a line using automatic machines where nobody other than experienced workers can make input plans of the line.

Input plans are frequently changed by machine problems.

### • Solution

The scheduling computer determines the input schedule of the line according to the production plan and operating condition of the line.

Attach to each magazine or pallet in the line the Data Carrier that has destination and automatic machine control data to be read at the branching points in the line to distribute the magazine or pallet. Each automatic machine reads the automatic machine control data to make line arrangement change.

### • Advantage

The load of the computer is reduced by making the computer responsible for scheduling and the ID System responsible for magazine or pallet transportation and the control of all automatic machines.

The ID System makes it possible to make detailed input plans even if machine problems occur.

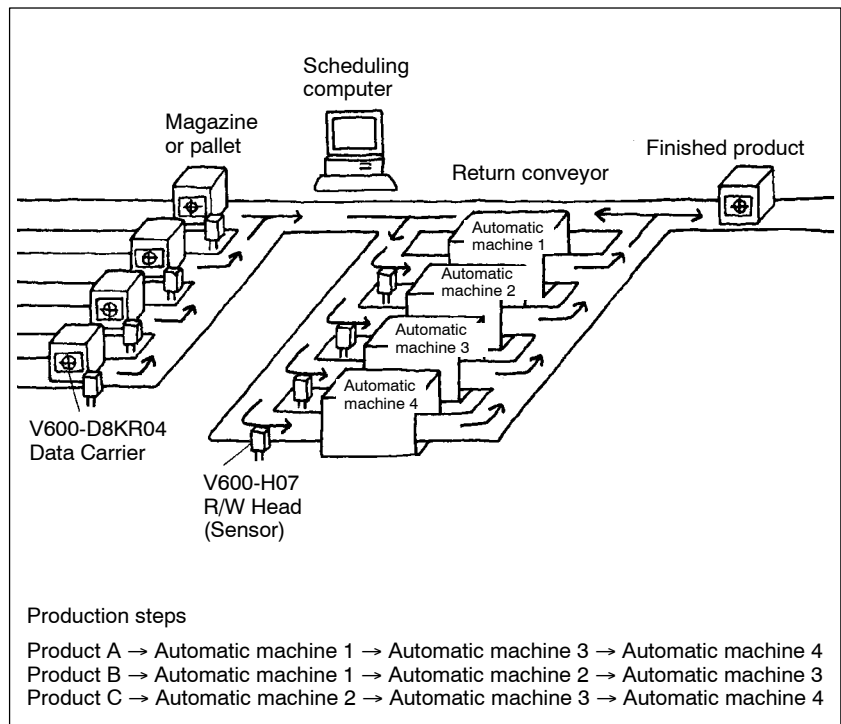



## Line Management

### Detention-time Management

V600-D2KR16 Data Carrier  
V600-H11 R/W Head (Sensor)  
V600-CD1D-V3 ID Controller

- **Problem**

There is a production site with a need for the management of the efficiency of all on-site installations by controlling the detention time of each product in every line.

- **Solution**

The control of input and output in advance makes it possible to control the detention time and analyze the lead time of each product.

- **Advantage**

The system makes it possible to standardize each line.

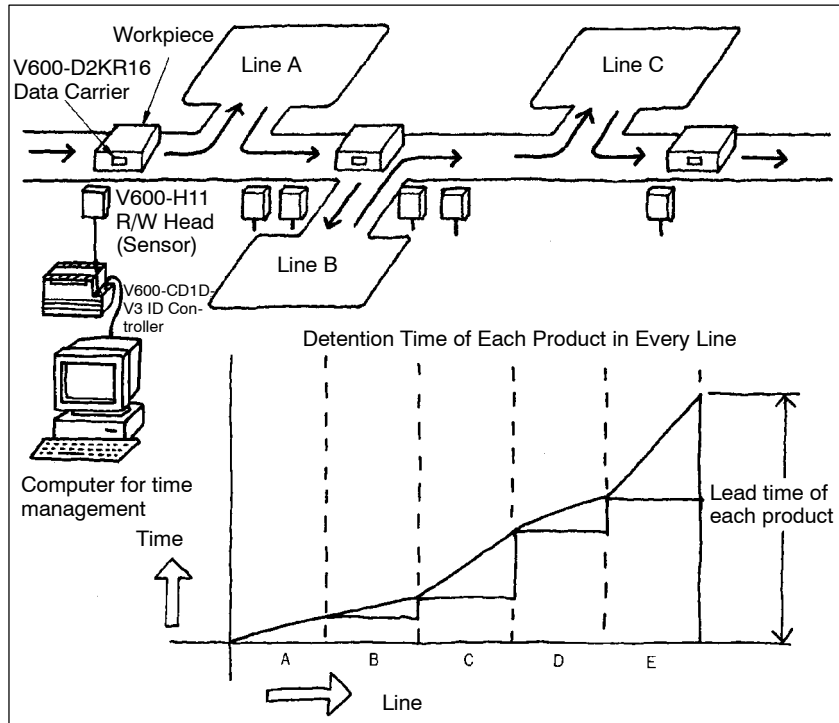

## Transfer

### Automatic Traffic Control of an Automatic Guided Vehicle

V600-D23P66 Data Carrier  
V600-HS63 R/W Head (Sensor)  
V600-HAM91 Multi-functional Amplifier (Intelligent Flag)

- **Problem**

There is a production site with a need for the automatic traffic control of automatic guided vehicles.

The layout of the production site is complicated with a large number of branching points and stations, which is beyond the program or screen image capability of the automatic guided vehicles.

A system that is as simple and economical as possible is desired.

- **Solution**

Attach the R/W Head to each automatic guided vehicle and embed in the runways Data Carriers with branching and running condition data that is read by the R/H Head for the automatic traffic control of automatic guided vehicles.

- **Advantage**

This system can flexibly keep up with layout changes.

The address data in the Data Carrier can be read to give instructions to each station along with the automatic traffic control information.

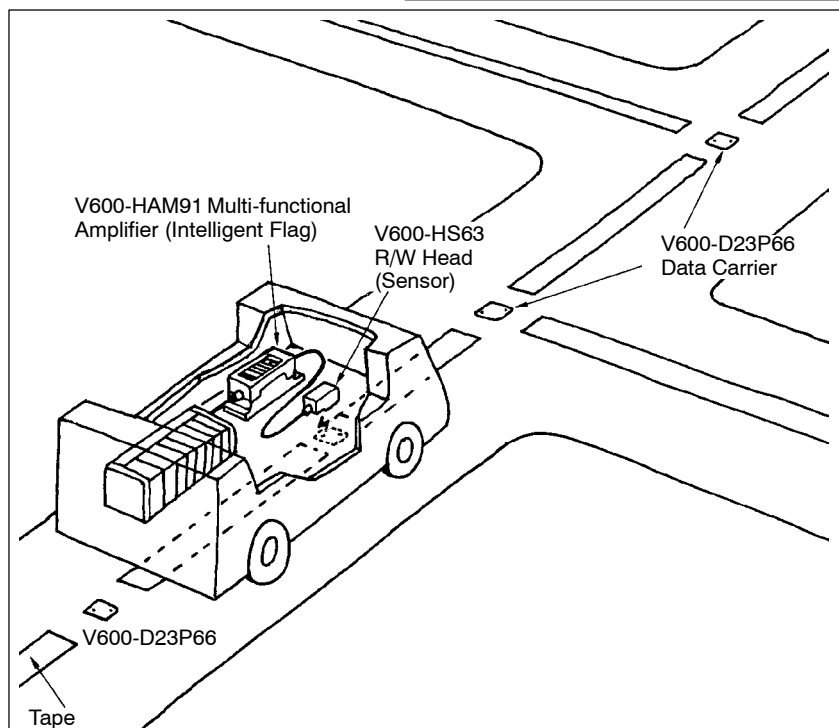

## Inspection and Quality Control

### Flexible Changes of Inspection and Adjustment Lines

V600-D23P66 Data Carrier  
 V600-HS63 R/W Head (Sensor)  
 V600-HAM91 Multi-functional Amplifier (Controller)

#### • Problem

There is a production site handling a wide variety of products with a need for easy inspection type selection according to the product.

Automatic quality inspection, the clarification of the condition of improper products, and prompt adjustments of the improper products are required.

#### • Solution

Attach to each pallet in the line the Data Carrier that has product data to be read in each inspection line for proper inspections according to the product. Then, inspection results are written to the Data Carrier.

Improper products are transferred to an adjustment line according to their condition. The improper products are re-inspected after they are properly repaired.

#### • Advantage

This system unifies the quantitative data of each inspection line, thus making it possible to utilize the data with ease.

The address data in the Data Carrier can be read to give instructions to each station along with the automatic operation control information.

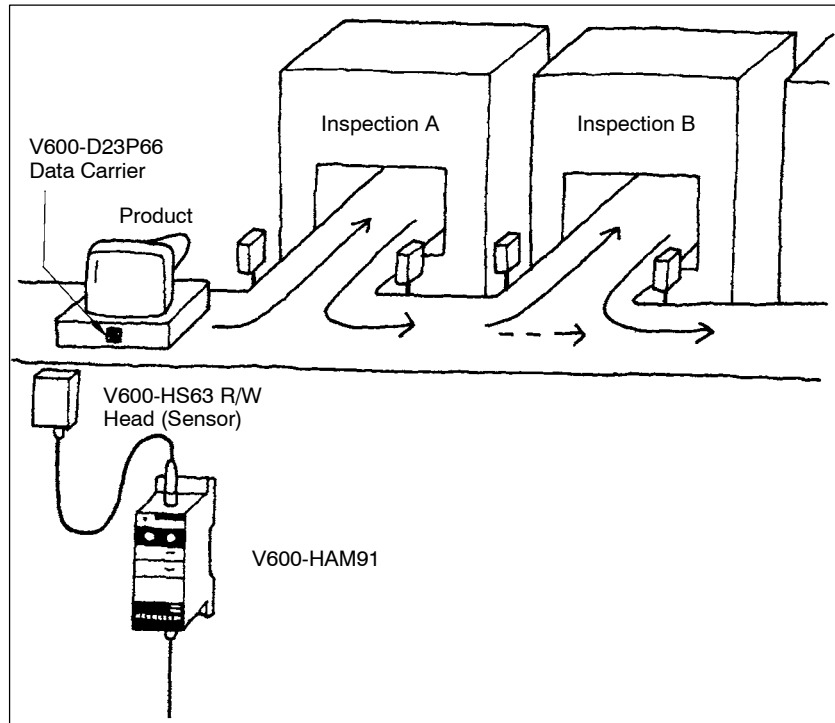

## Inspection and Quality Control

### Discrimination of Blood Specimens

V600-D23P54 Data Carrier  
 V600-H52 R/W Head (Sensor)  
 C200H-IDS01-V1 ID Controller

#### • Problem

There is a laboratory where blood specimens are discriminated according to the information on paper slips, which can cause careless mistakes and clerical errors. Thus the laboratory is inefficient.

#### • Solution

Attach a bar-code sticker to each test tube and the Data Carrier to each rack of test tubes. Then the data of the test tube can be read from the bar code, information on each rack can be written to the Data Carrier, and the rack sent to the first inspection stage.

The result of inspection is written to the Data Carrier and the rack is transferred to the next inspection stage.

#### • Advantage

The bar-code system is used for the inspection of each test tube while the ID System is used for the handling of racks of test tubes, which ensures the efficient data management of specimens and prevents careless mistakes and clerical errors.

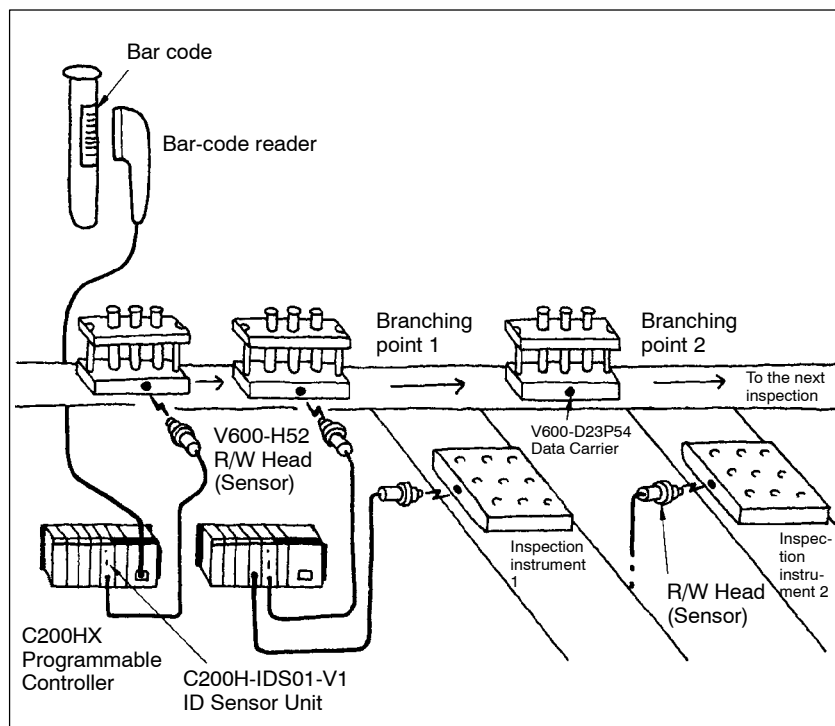

## Inspection and Quality Control

### Production Record Management

V600-D8KR13 Data Carrier  
 V600-H11 R/W Head (Sensor)  
 V600-CA1A-V2 ID Controller  
 C200H-IDS01-V1 ID Controller

• **Problem**

There is a production site where the production history is kept on record according to the information on paper slips, which can cause careless mistakes and clerical errors.

On-site workers keep the production history on record, which is inefficient.

• **Solution**

Attach a bar-code sticker and the Data Carrier to each component box. The record of the components in the box is read from the bar code in the on-site assembly line and information on the record is written to the Data Carrier.

In the inspection line, the record of inspection of the components is written to the Data Carrier.

At the on-site totaling station, the records of the components and inspection are written from the Data Carrier to an optical filing device.

• **Advantage**

This system makes it possible to collect production record data automatically and efficiently.

This system prevents careless mistakes and clerical errors.

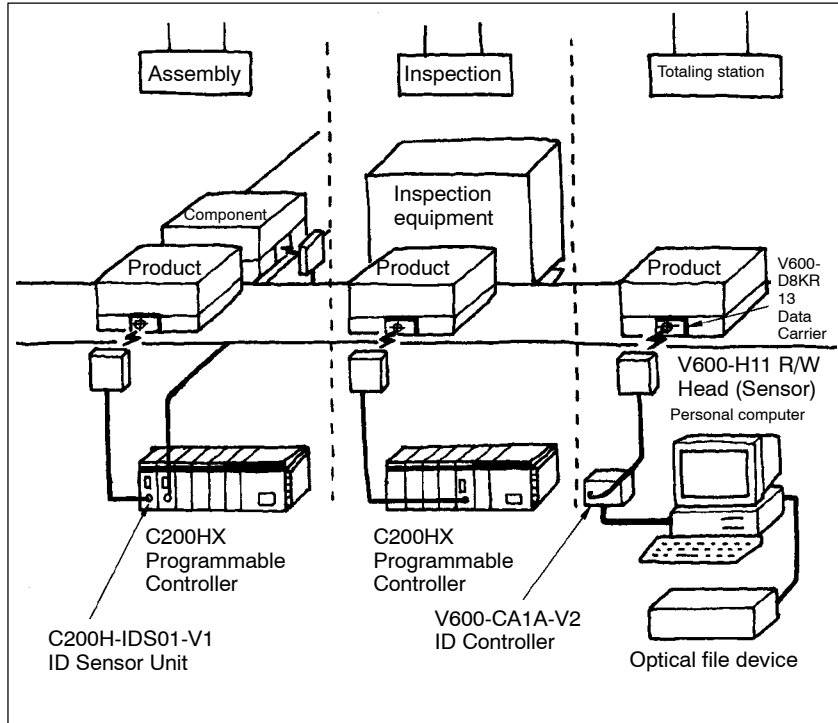

## Inspection and Quality Control

### Quality Control in an OA Equipment Inspection Line

V600-D4KR11T Data Carrier  
 V630-H11T R/W Head

• **Problem**

There is a production site that has an inspection line where product discrimination, inspection instruction, and inspection result data are given on paper slips, which can cause careless mistakes and clerical errors. Thus the line is inefficient.

• **Solution**

Attach to each product the Data Carrier that has product and inspection instruction data to be read at the inspection line for the automatic preparation of inspection items.

The Data Carrier has a capacity of 4 Kbytes for storing inspection results.

• **Advantage**

The V630 Series use an optical data communications method for a communications distance of 20 cm, and can be applied to conventional lines with only minor modifications to the lines.

Data can be written to and read from the Data Carrier at a high communications speed of 19,200 bps regardless of whether the Data Carrier is moving or not.

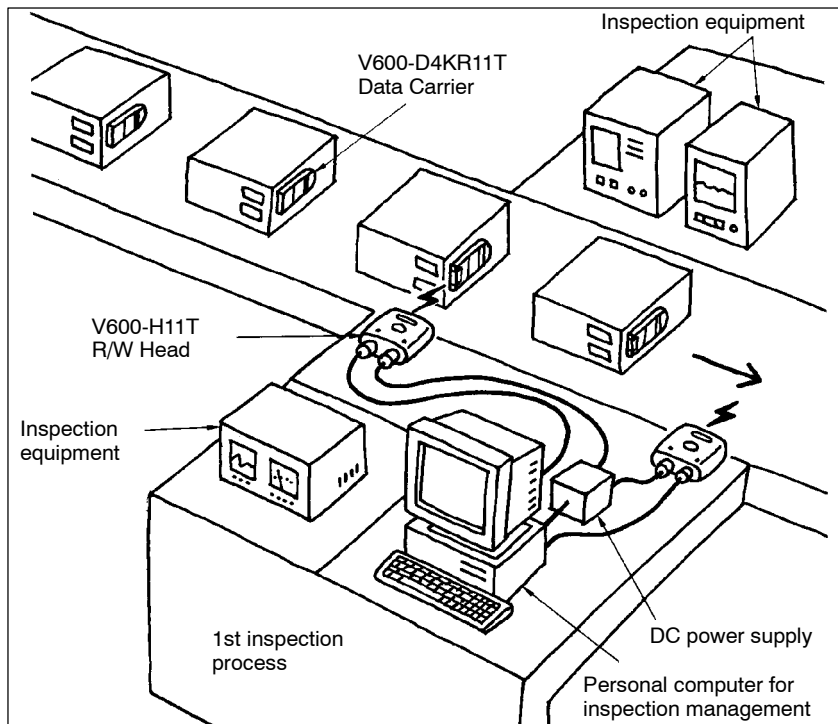

## Inspection and Quality Control

### Compliance with ISO, Product Liability Law, and GMP

#### • Problem

There is a production site that has inspection lines with a need for the automatic management of information on inspection results (i.e., whether inspected products are OK or not) and product codes in each inspection line for efficient product inspection.

Mechanical flags are not preferred because they are costly and often result in mechanical problems.

The reliable management of inspection progress without omission of inspection items is desired.

#### • Solution

Attach the Data Carrier to the pallet of each product. Use the 16-bit data of the Data Carrier to store the product code and inspection result (i.e., "1" if the inspection result is OK, or "0" if not) of the product.

In each inspection line, the inspection result (i.e., "1" if the inspection result is OK, "0" if not) is written to the bit corresponding to the line number.

All the inspection results of the product are checked in the final inspection line. If all the corresponding bits are set to 1, the product is deemed OK, otherwise the product is returned for readjustments.

#### • Advantage

The Intelligent Flag is similar to mechanical flags and sensors in use.

The wiring-saving mode and parity-check output function are available to the 16-bit Intelligent Flag II, thus making it possible to eliminate on-site wiring problems.

V600-D23P61 Data Carrier  
V600-HS63 R/W Head (Sensor)  
V600-HAM91 Multi-functional Amplifier (Intelligent Flag)  
V600-HAR92 Multi-functional Amplifier (Intelligent Flag II)

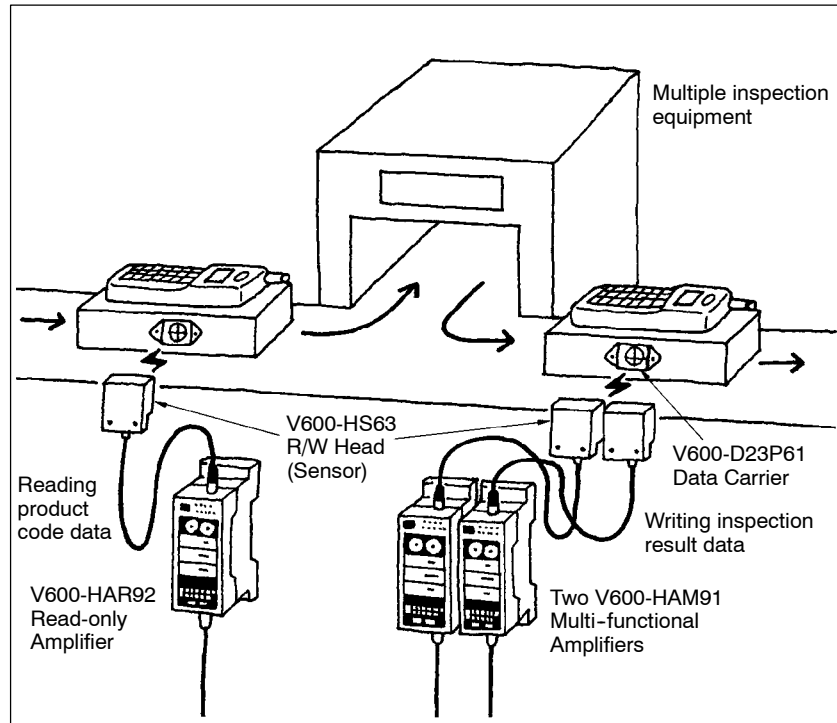

## Distribution

### Paper-slip Elimination in In-house Distribution Management

#### • Problem

There is a production site with a need for the simplification of shipment and delivery slips exchanged between factories and with subcontractors to prevent careless mistakes and clerical errors and to streamline the production site.

#### • Solution

Apply the POS bar-code system to market distribution and the ID System to in-house distribution so that both systems will be linked and efficiently managed.

#### • Advantage

The bar-code system and ID System applied to their respective fields ensure the efficient management of distribution data, the prevention of careless mistakes and clerical errors, and an increase in the efficiency of the distribution operation of the site.

V600-D23P71 Data Carrier  
V600-H07 R/W Head (Sensor)  
V600-CD1D-V3 ID Controller

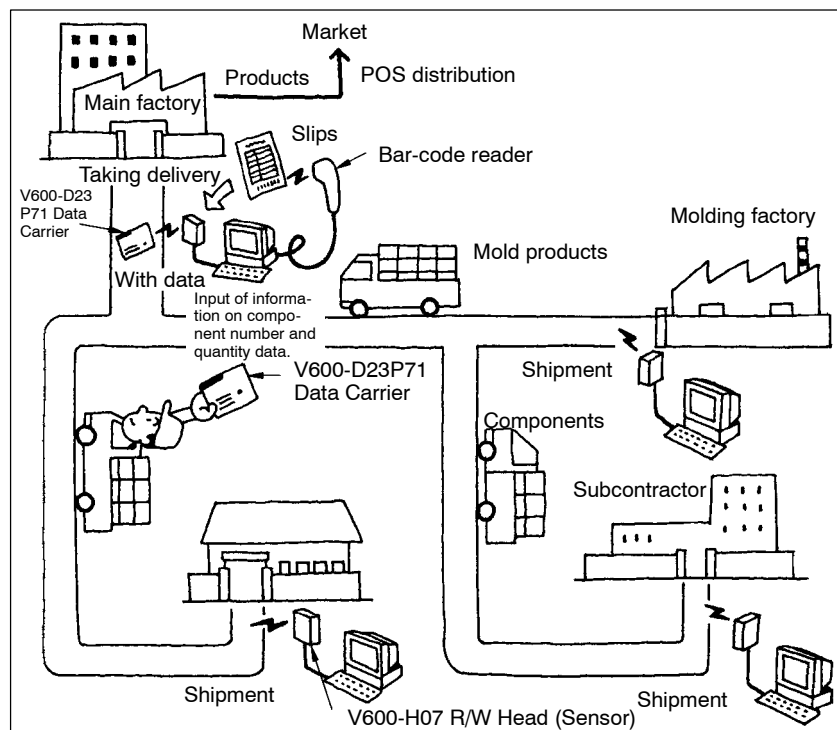

## Distribution

### Automatization of Picking Instructions

V600-D23P72 Data Carrier  
V600-H11 R/W Head (Sensor)  
V600-CD1D-V3 ID Controller

- **Problem**

There is a distribution office where picking instructions are given on paper slips, which can cause careless mistakes and clerical errors.

Thus, picking work with paper slips is inefficient.

- **Solution**

The Data Carrier that has picking instruction data is issued by the office.

The R/W Head on the picking cart reads the picking data.

The picking instructions appear on the display panel on the picking cart and on-site workers perform picking work according to the picking instructions.

- **Advantage**

When the picking work completes, completion data is written to the Data Carrier immediately, and the products are shipped from the shipping station.

The automatization of picking instructions prevents careless mistakes and clerical errors and greatly increases the efficiency of picking work.

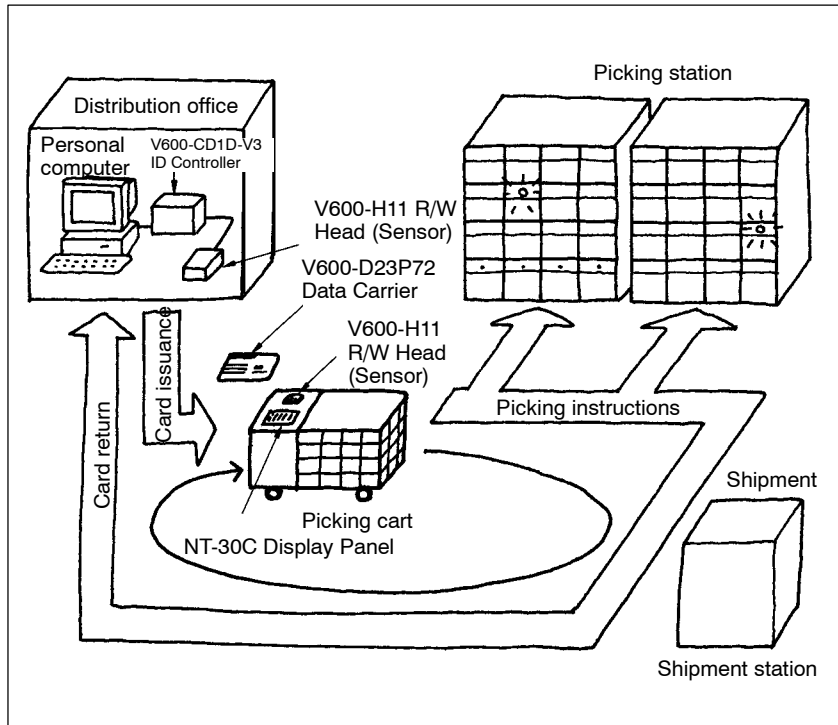

## Distribution

### Automatization of Distribution Management

V600-D23P71 Data Carrier  
V600-H07 R/W Head (Sensor)  
IDSC ID Controller

- **Problem**

There is a distribution site with a need for warehouse automatization that does not require warehouse workers.

Ease of warehouse data changes is desired.

- **Solution**

Attach the Data Carrier to each cargo item to read distribution data and use the ID Controller to give instructions on the distribution of the cargo.

- **Advantage**

This system makes it possible to read or change warehouse data automatically or manually.

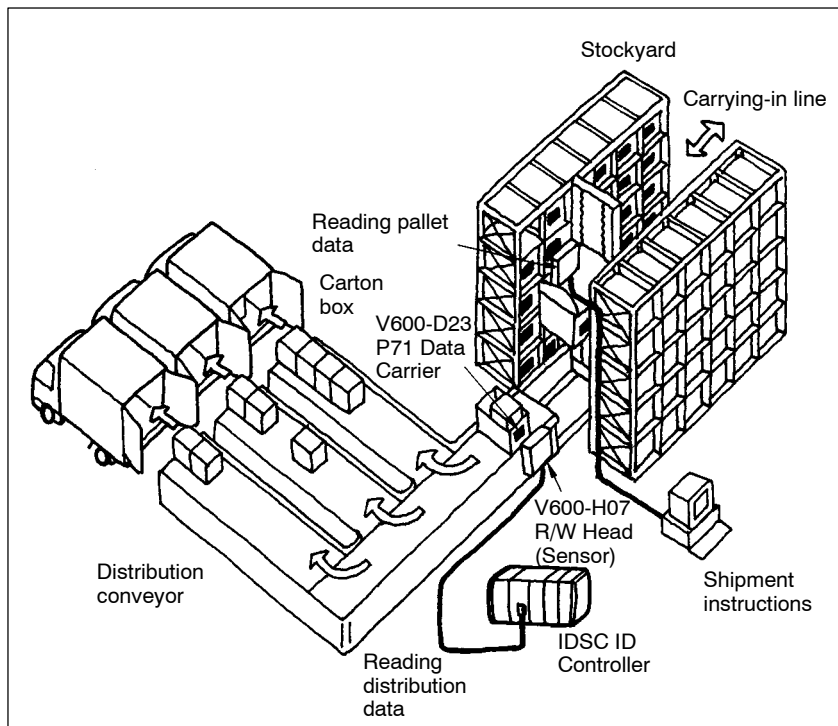

## Distribution

### Vehicle Weigh-point

V620-D8KR01 Data Carrier  
V620-H01 R/W Antenna  
V620-CA2A ID Controller

#### • Problem

There is an office that has a scaling site with a need for the prevention of careless mistakes and clerical errors by eliminating manual truck discrimination or key input by truck drivers.

#### • Solution

Attach the Data Carrier to the side of each truck and mount the R/W Antenna to the on-site control panel. The identification data of the truck is read when the truck enters, and then the truck is weighed.

Weight data is written to the Data Carrier. After the truck discharges the cargo, the truck is weighed again before the truck leaves the site. Then the previous scaling data of the truck is read and the difference is transmitted to the office.

#### • Advantage

This system prevents careless mistakes and clerical errors and saves on the number of workers.

This system is free of maintenance and ensures the wireless transmission of data for a distance of 2 m without mechanical contact.

Weight data is written to and read from the Data Carrier directly, which makes it possible to process the weight data off-line.

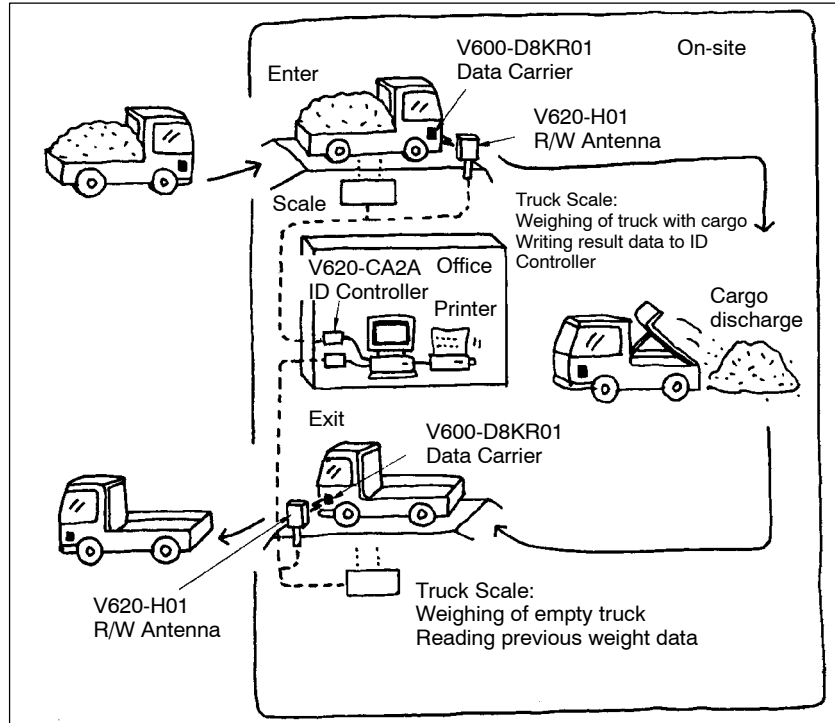

## Distribution

### Product Delivery Management

V600-D23P53, V600-D23P66,  
V600-D23P66SP, V600-D23P71  
Data Carrier  
V600-CH1D-C Handheld Reader Writer

#### • Problem

Goods delivery management with paper slips issued manually is inefficient.

Paper slips are often damaged in the rain or in the market.

#### • Solution

Attach the Data Carrier to each pallet or container for the delivery of goods.

Input into the Data Carrier information on the goods, quantity, price, processing factory name, processing date, and destination. This is ideal when the goods are fresh and need to be quickly delivered.

At the time of the delivery of the goods, the information in the Data Carrier is read with the Handheld Reader Writer to check that the destination is correct. A slip or receipt is issued if necessary.

#### • Advantage

Unlike bar-code stickers or paper slips, this system withstands water and dust and is ideal for tough environments.

The V600-D23P66SP Data Carrier is ideal for the system because this model is of a Teflon (PFA) dual-package construction, highly chemical-resistant, and can be washed with chemicals. Furthermore, this model withstands a maximum temperature of 110°C. Therefore, there is no need to remove the Data Carrier from the pallet or container at the time of sterilization.

The Handheld Reader Writer with a printer can issue slips and receipts on the spot, thus improving the efficiency of documentation when goods are delivered. Furthermore, the data in the Handheld Reader Writer is available for office use by inputting the data into a personal computer.

**Note:** Teflon is a registered trademark of the Dupont Company and the Mitsui Dupont Chemical Company for their fluoride resin.

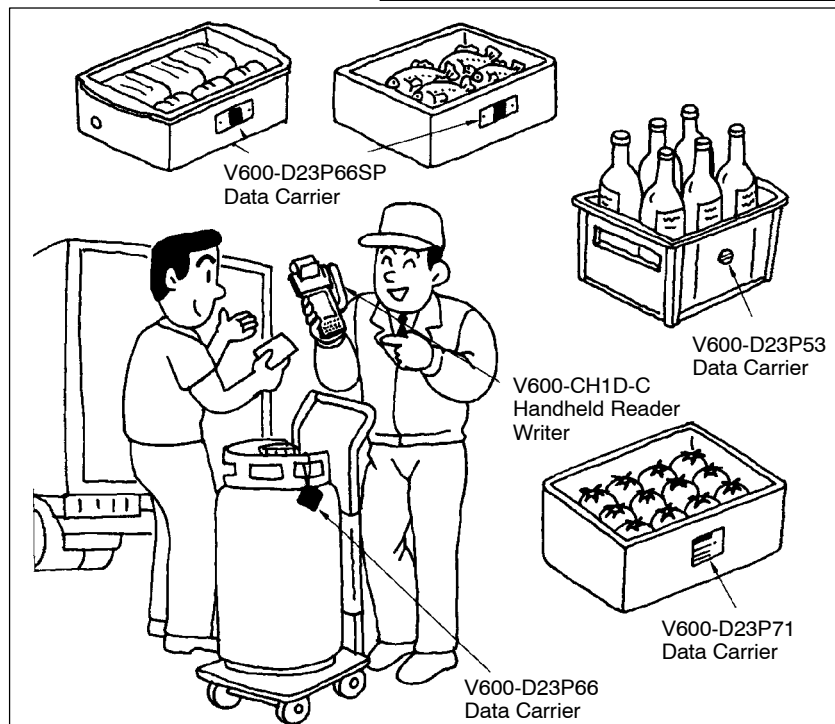

## Distribution

# Lot Management of Products and Transfer of Information

V600-D23P71 Data Carrier  
V600-CH1D-C Handheld Reader Writer

- **Problem**

There is a distribution site where product distribution from carton boxes to plastic containers is inefficient because each lot of products is distributed manually according to the information on paper slips.

- **Solution**

When taking out products from a carton box, read the bar codes on the products with a handheld bar-code reader.

When the products are transferred to a plastic container, use the management information in the on-site personal computer and write the information including quantity and product type data with the Handheld Reader Writer to the Data Carrier to be attached to the plastic container.

- **Advantage**

By using the personal computer, the bar-code data is written to the Data Carrier accurately.

If distribution data for the products is added to the information in the personal computer and the Data Carrier, the automatization of product distribution is possible.

The Data Carrier can be attached to and removed from the plastic container with ease if the Special Holder is fixed on the plastic container with ultrasonic welding.

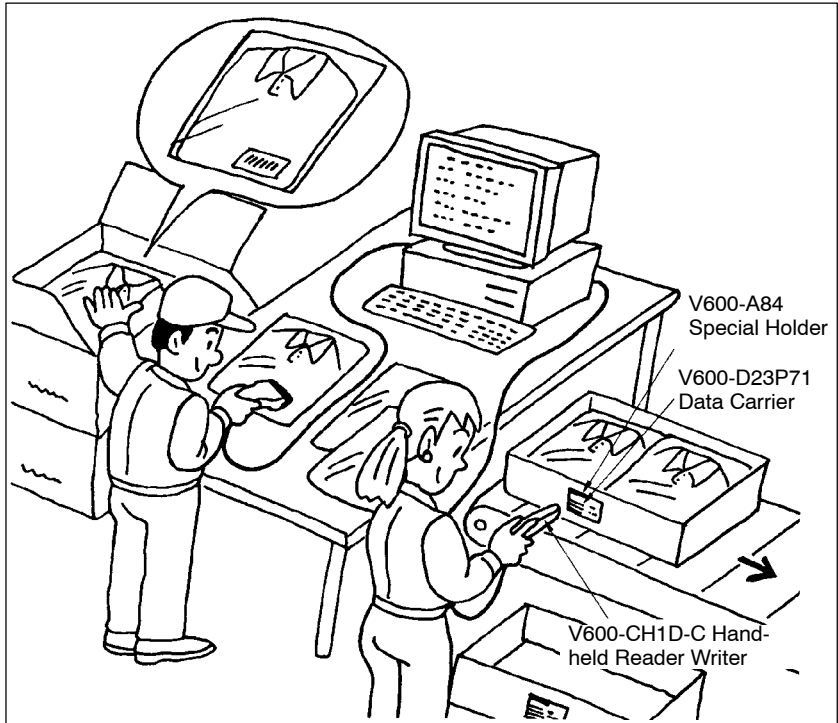

## Medicine, Food, and Chemical

# Production Condition Management

V600-D23P66SP Data Carrier  
V600-H11 R/W Head (Sensor)  
C200H-IDS01-V1 ID Controller

- **Problem**

There is a pharmaceutical production site that has a chemical mixing line with a need for automatizing the management of product type, weighing, mixing, and mixing condition data.

- **Solution**

Attach to each mixing container the Data Carrier that has information on the lot number, mixed chemicals, chemical mixing data, weight data and others. Chemicals are mixed according to the information and the result of the mixture is written to the Data Carrier.

- **Advantage**

This system automatizes data management and work instructions, thus preventing careless mistakes and clerical errors and improving the productivity of the line.

The V600-D23P66SP Data Carrier is ideal for the line because this model is of a Teflon (PFA) dual-package construction, highly resistant to chemicals, and ideal for suppressing the propagation of microorganisms.

The V600-D23P66SP Data Carrier withstands a maximum temperature of 110°C.

**Note:** Teflon is a registered trademark of the Dupont Company and the Mitsui Dupont Chemical Company for their fluoride resin.

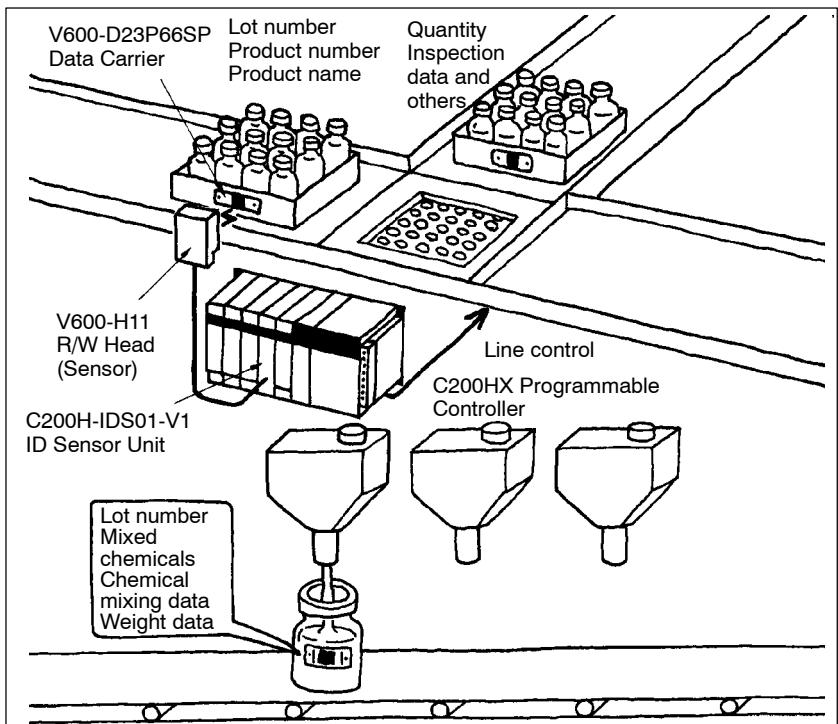

## Medicine, Food, and Chemical

### Chemical Bottle Management

V600-D23P61 Data Carrier  
V600-H11 R/W Head (Sensor)  
IDSC ID Controller

#### • Problem

There is a pharmaceutical production site where the management of chemical bottle records with paper slips often causes careless mistakes and clerical errors. Thus the site is inefficient.

#### • Solution

Picking instructions can be given by attaching to each chemical bottle the Data Carrier that has product information and using a personal computer for the management of the location of the chemical bottle.

#### • Advantage

This system prevents careless mistakes and clerical errors.

Records of medicines can be managed with the personal computer, which makes it possible to create daily or monthly reports automatically.

It is possible to make use of this system for GMP data storage and validation purposes.

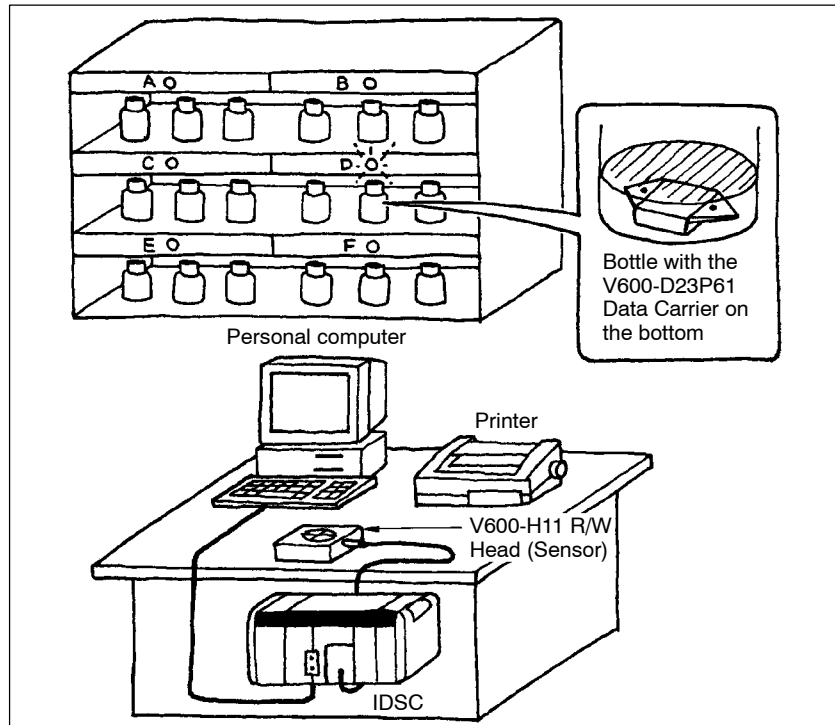

## Medicine, Food, and Chemical

### Automated Material Mixing and Weighing System

V600-D8KR04 Data Carrier  
V600-H07 R/W Head (Sensor)  
C200H-IDS01-V1 ID Controller

#### • Problem

There is a production site with chemical mixing lines that are controlled with steel punch cards that have punch holes used as data bits for chemical mixing instructions. In this case, mistakes in mixing chemicals due to incorrect card insertion are not found until the mixture reaches the inspection line of the site.

An increase in the number of product types requires additional sensors at each station and punch cards, which is difficult.

#### • Solution

Attach to each container the Data Carrier that has chemical mixing data to be read at the lines and the instructed materials are provided by the hoppers of the lines in the instructed quantities according to the mechanical mixing data. Then the results of the mixture are written to the Data Carrier.

#### • Advantage

This system automates product mixing instructions and data management, thus preventing careless mistakes and clerical errors and improving the productivity of the lines.

This system makes it possible to keep up with sudden line rearrangements by just rewriting the data.

All data can be collected at the final line.

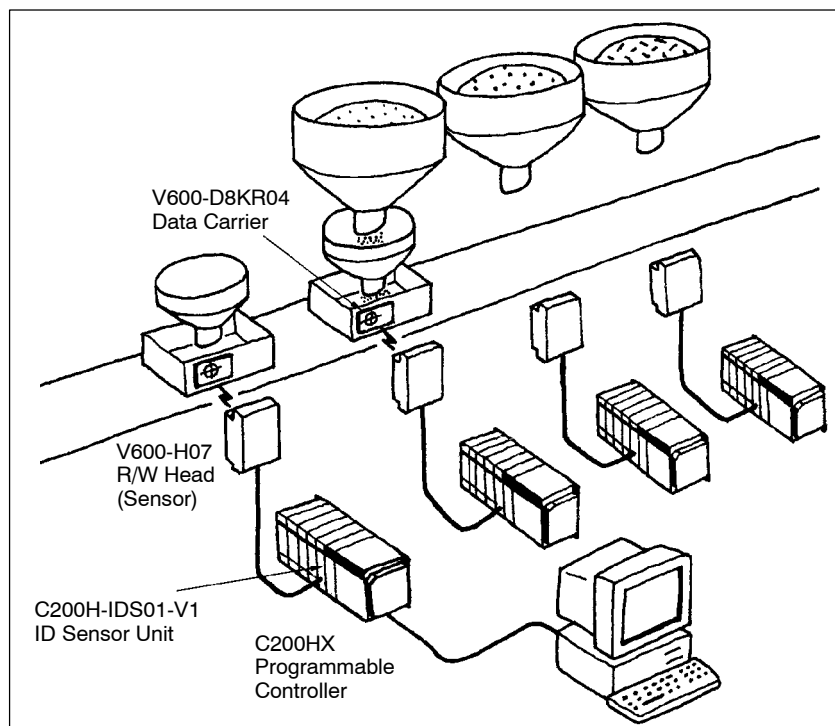



## Customer and Labour Management

### Customer Management in Sauna Baths

V600-D23P66 Data Carrier  
V600-A70-S Wrist-belt Data Carrier  
V600-H07 R/W Head (Sensor)  
V600-CD1D-V3 ID Controller

- **Problem**

There is an exclusive-membership club with a need for the registration, storage, and management of customer information.

A credit settlement system is desired for the sale of goods and the use of the facilities.

- **Solution**

Provide each customer with the Data Carrier used as a member's card with a customer code, which is read. Information on the customer's use of the facilities is also written to the Data Carrier.

- **Advantage**

This system automatizes the data management of the use of the facilities and the sale of goods, thus making it possible to collect marketing data for customer analysis and other uses.

The V600-D23P66SP Data Carrier withstands a maximum temperature of 110°C, which can be used in sauna baths.

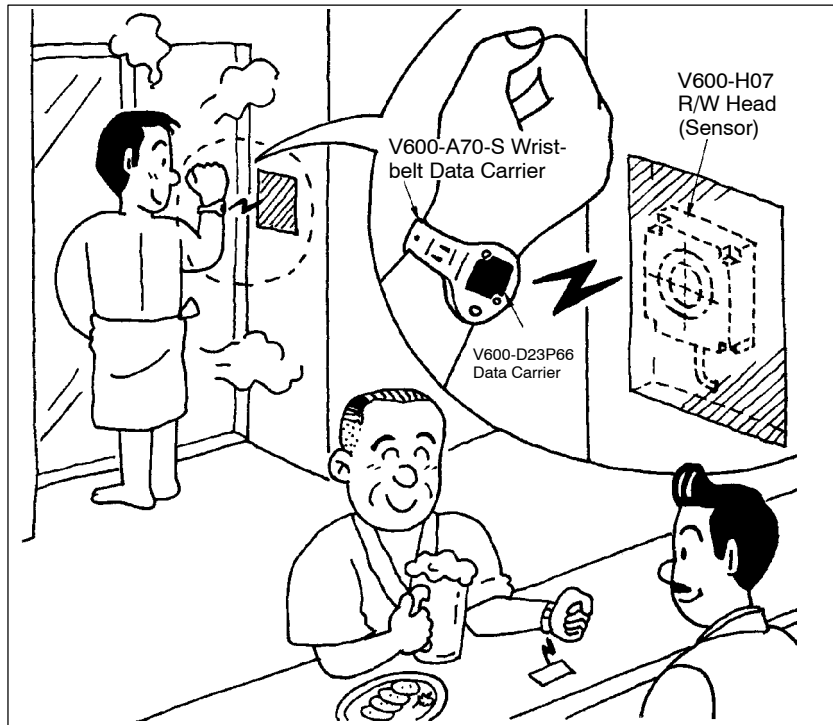

## Customer and Labour Management

### Physical Access Control

V600-D23P71 Data Carrier  
V600-HS63 R/W Head (Sensor)  
V600-HAM91 Multi-functional Amplifier (Intelligent Flag)

- **Problem**

There is a need for unlocking a door only for people with a special registered code, the arrangement of which is difficult with a personal computer due to cost and space.

- **Solution**

A combination of the V600-HAM91, a compact Programmable Controller, and Sensor Controller can make an ideal physical access control system.

- **Advantage**

The verification function of the V600-HAM91 allows easy discrimination between the preset code registered on the door side and the code registered on the Data Carrier carried by the holders.

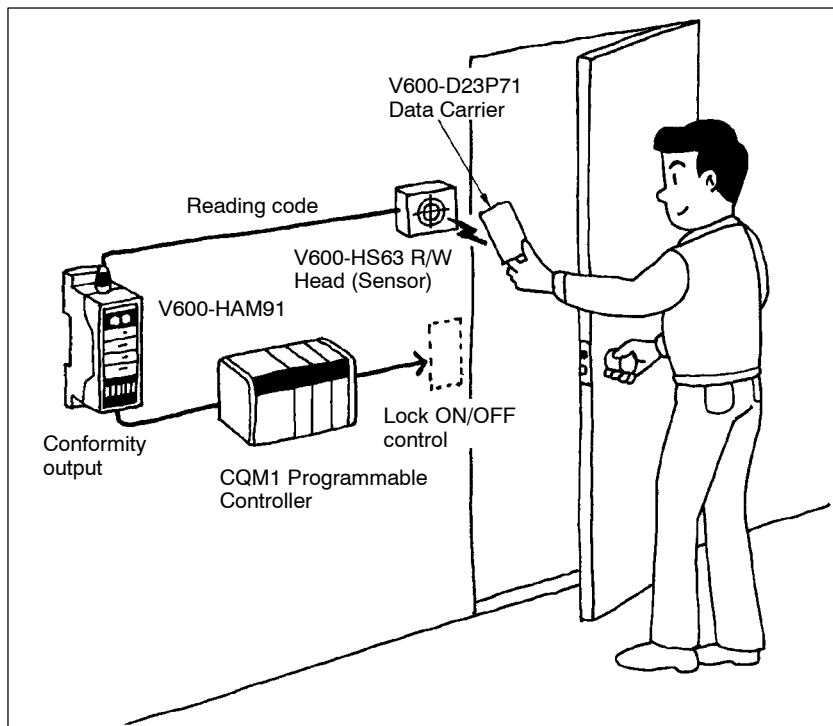

## Customer and Labour Management

### Time and Attendance

V600-D23P71 Data Carrier  
V600-H07 R/W Head (Sensor)

- **Problem**

There is an on-site office with a need for checking the whereabouts of underground tunnel workers.

- **Solution**

Provide each on-site worker with the Data Carrier that has individual identity data to be read by the R/W Head located in each on-site section so that the whereabouts of the on-site worker can be managed by the personal computer at the on-site office.

- **Advantage**

Information on the whereabouts of the on-site worker is collected from each section automatically, which ensures the safety of the on-site worker.

On-site workers can be allocated efficiently for improvement in on-site work.

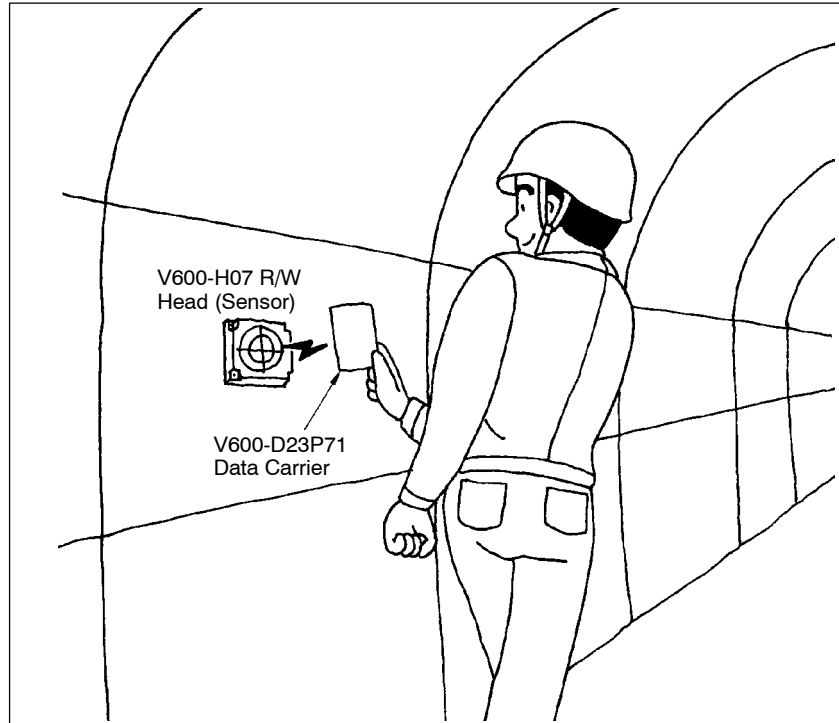

## Customer and Labour Management

### Car Rental Management

V600-D23P66 Data Carrier  
V600-H11 R/W Head (Sensor)  
V600-CD1D-V3 ID Controller

- **Problem**

There is a car rental agency where car rental management is done with handwritten paper slips, which causes careless mistakes and clerical errors.

Totaling work, such as daily report filling, is time-consuming and inefficient.

- **Solution**

Provide the car keys of each car with a key ring attached to the Data Carrier and use a personal computer to manage information on a car going out and returning.

- **Advantage**

This system prevents careless mistakes and clerical errors.

There is no need to prepare paper slips, which makes the car rental management highly efficient.

Using the data input to the personal computer, the personal computer can output daily and monthly reports with ease.

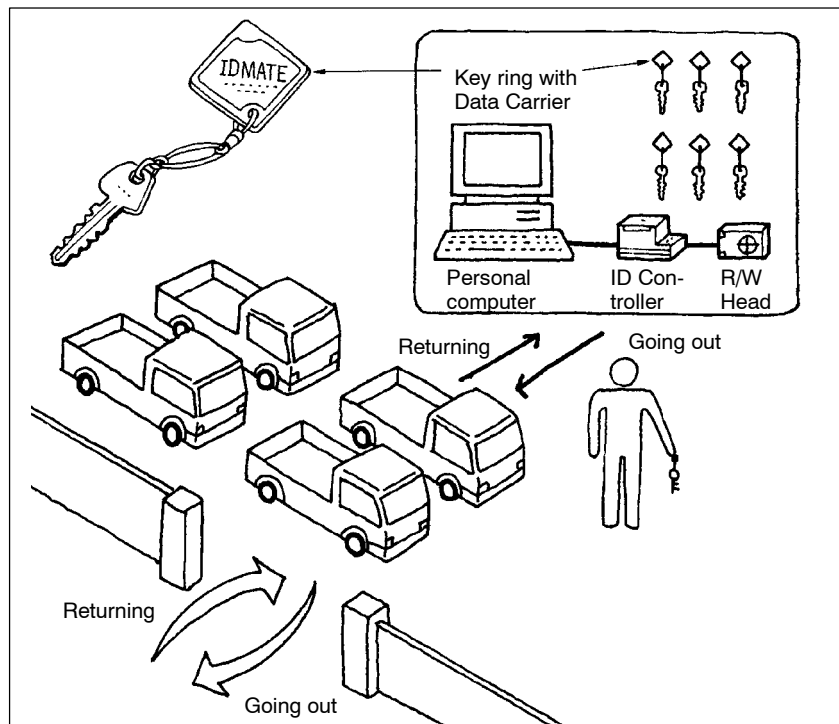

## Customer and Labour Management

### Vehicle Entrance and Departure Control

V600-D23P71 Data Carrier  
V600-H07 R/W Head (Sensor)

- **Problem**

There is a distribution site where trucks coming in and going out are checked with punch cards and a card reader that often has mechanical problems.

The card reader is not very environment-resistant. Therefore, it is easily influenced by dust, rainwater, temperature, and humidity.

- **Solution**

Provide each driver with a Data Carrier that has vehicle data that is read by the R/W Head at the gate at the time of entrance and departure.

- **Advantage**

This system is free of maintenance and both the Data Carrier and R/W Head are highly environment-resistant with no mechanical contact required.

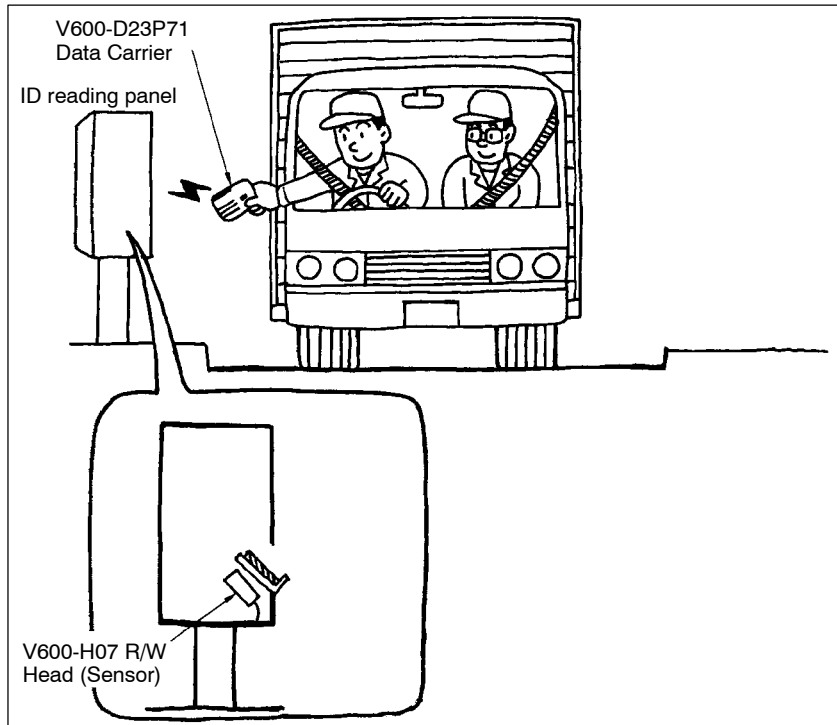

## Customer and Labour Management

### Freight Management

V600-D8KR01 Data Carrier  
V620-H02 R/W Antenna  
C200H-IDS21 ID Controller

- **Problem**

There is a need for automatically controlling dollies for on-site freight transportation for dam, tunnel, and subway construction sites.

- **Solution**

Embed the Data Carrier alongside the tracks at each station and where the operation control of the dollies are required.

The Data Carrier stores information on station number data, cart number data, and operation control instructions, such as start, stop, acceleration, deceleration, and other data.

Attach the R/W Antenna to the dolly so that the antenna receives information transmitted from the Data Carrier with which the dolly is in operation control.

- **Advantage**

This system requires a communications distance of 50 cm or more. Therefore, use the V620-series Data Carrier, which is highly resistant to noise and ensures the microwave transmission of information.

The Data Carrier is ideal for on-site use because the Data Carrier is more dust-resistant than bar codes.

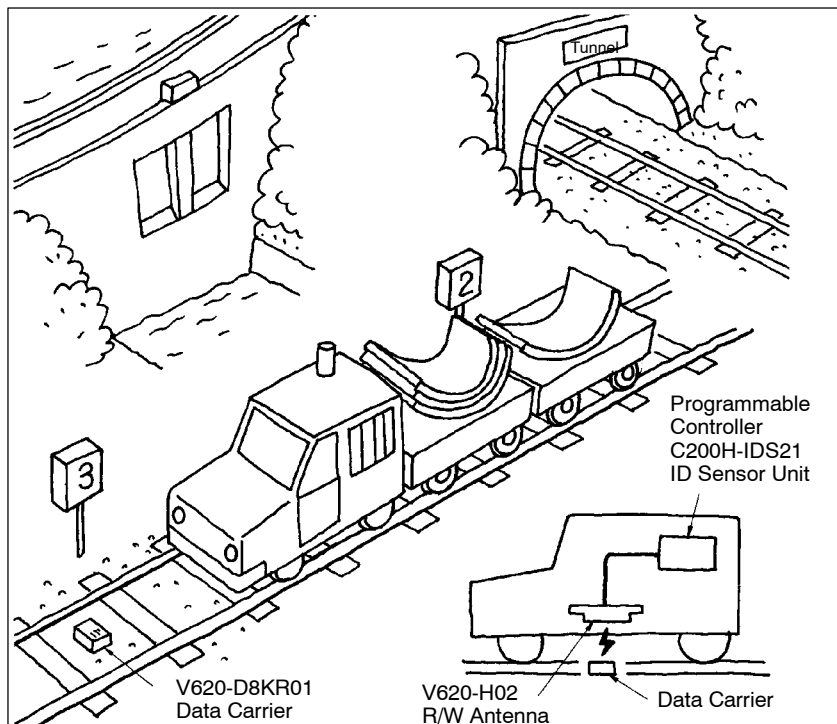

## Customer and Labour Management

### Cashless Theme Park

V600-D23P71, V600-D23P66, and  
V600-A70□-S Wrist Strap Data Carrier  
V600-CH1D-C Handheld Reader Writer

#### • Problem

There is a need for a credit settlement system for pool sides and other places where visitors cannot keep money.

It is desirable that no cash be used in theme parks and other places crowded with people.

#### • Solution

Provide each visitor with a Data Carrier (of card or wrist-strap type) with a customer code that is read whenever the visitor purchases something, the charge of which is settled before the visitor leaves for home.

#### • Advantage

This system encourages visitors to purchase things because they need not carry money or pay on the spot whenever they purchase something.

This system improves the efficiency of each shop on the premises because the sales-clerks do not have to handle cash.

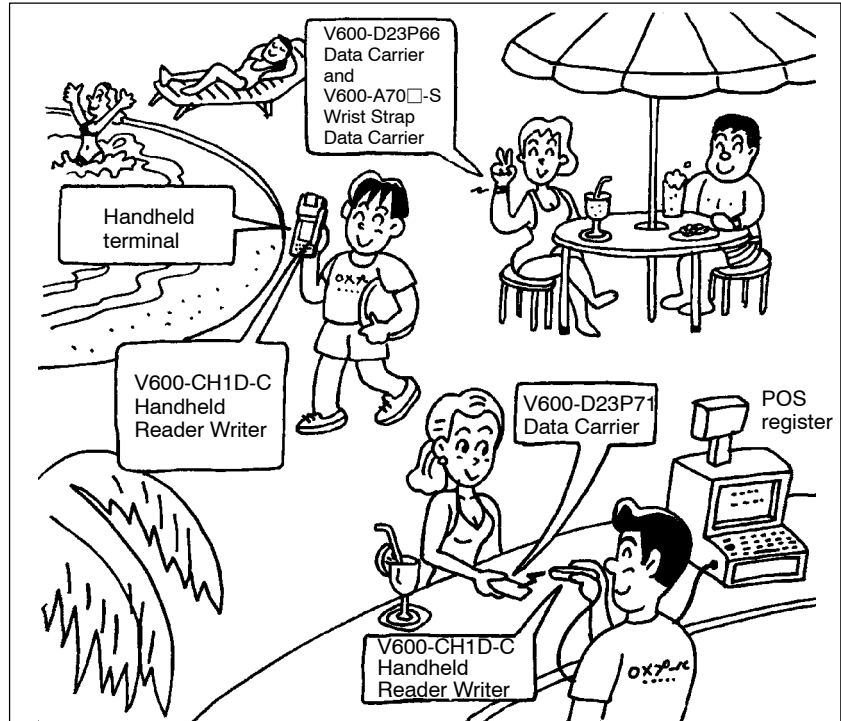

## Customer and Labour Management

### Car Park Vehicle Management

V600-D23P71 Data Carrier  
V600-H07 R/W Head (Sensor)  
C200H-IDS01-V1 ID Controller

#### • Problem

There is a multilevel car park for monthly customer use with a need for the elimination of mechanical problems that are caused by the deterioration of the magnetic card reader and vandalism.

#### • Solution

Provide each customer with a Data Carrier instead of the present magnetic pass, which reduces mechanical problems, constructs a more environment-resistive system, and adds value to the car park.

#### • Advantage

The Data Carrier system is a non-contact system, which makes it possible to construct a highly weatherproof console.

The console is almost free of maintenance because the console is free from magnetic head friction and resists acts of vandalism.

The customers will also have a better impression of the car park.

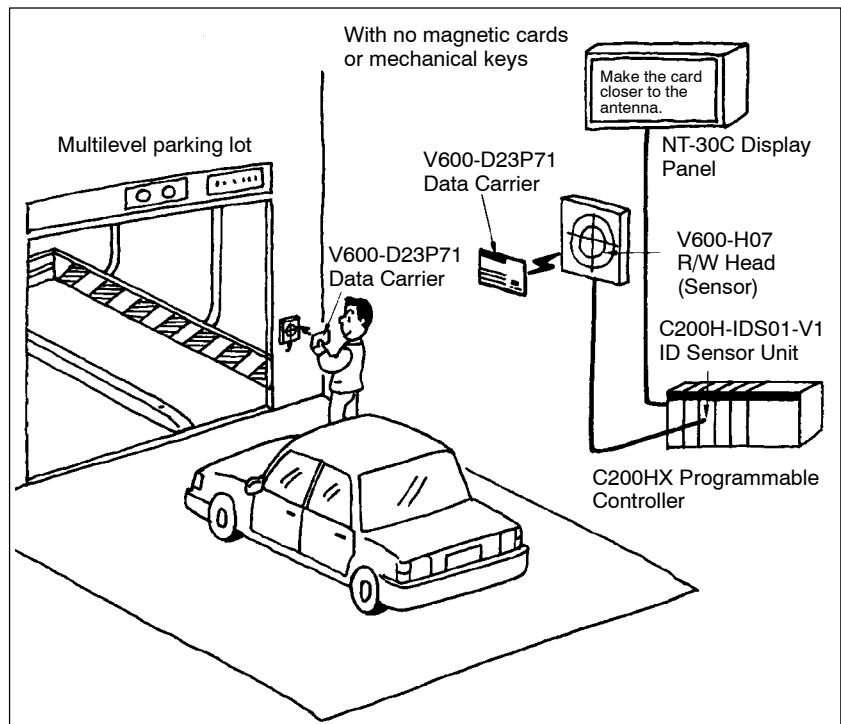

## Customer and Labour Management Equipment Rental / Asset Management

V600-D23P71 Data Carrier  
V600-CH1D-C Handheld Reader  
Writer

### • Problem

There is a need for the management of the records of rental construction equipment without use of paper documents.

Easy management of the rental records, inspection, and maintenance of rental construction equipment is desired.

### • Solution

Provide each piece of equipment with a Data Carrier that has equipment, rental, and inspection data.

Before a customer rents equipment, information is input on the customer, rental date, and expected return date into the Data Carrier.

The Handheld Reader Writer with a printer can issue slips and receipts on the spot.

### • Advantage

The Data Carrier is environment-resistive, withstands rainwater and dust, and operates without mechanical contact.

The ID System makes it possible to read and write data on the spot.



## Customer and Labour Management Ball Management at a Golf Driving Range

V600-D23P71 Data Carrier  
V600-H07 R/W Head (Sensor)  
V600-CD1D-V3 ID Controller

### • Problem

There is a golf driving range with a need for to eliminate prepaid cards for rental balls and adopt a conventional, yet smart cash payment system.

### • Solution

Provide each customer with the Data Carrier.

The Data Carrier can be inserted to the automatic tee-up machine like a prepaid card. Each hit is recorded by the Data Carrier.

The customer pays the fee at the front desk after the customer finishes practicing golf. The settlement can be made according to the data in the Data Carrier.

### • Advantage

#### Customers

1. The customer can settle the fee using the conventional system and pays for the number of hits only, which is cheaper than the prepaid card system.
2. The Data Carrier can be inserted in any direction and has no "correct" surface or back sides.

#### Managers

1. There is no need to issue prepaid cards, which eliminates expenditure on automatic card vending machines.
2. No running cost of cards is required.
3. The Data Carrier is environment-resistive, free of maintenance, withstands rainwater and dust, and operates without mechanical contact.
4. Ball data is directly processed, which prevents illegal acts.
5. The Data Carrier is battery-less and its electrical life is limitless.

#### Machine Manufacturers

1. The conventional access mechanism for prepaid cards can be replaced by just the ID System component.

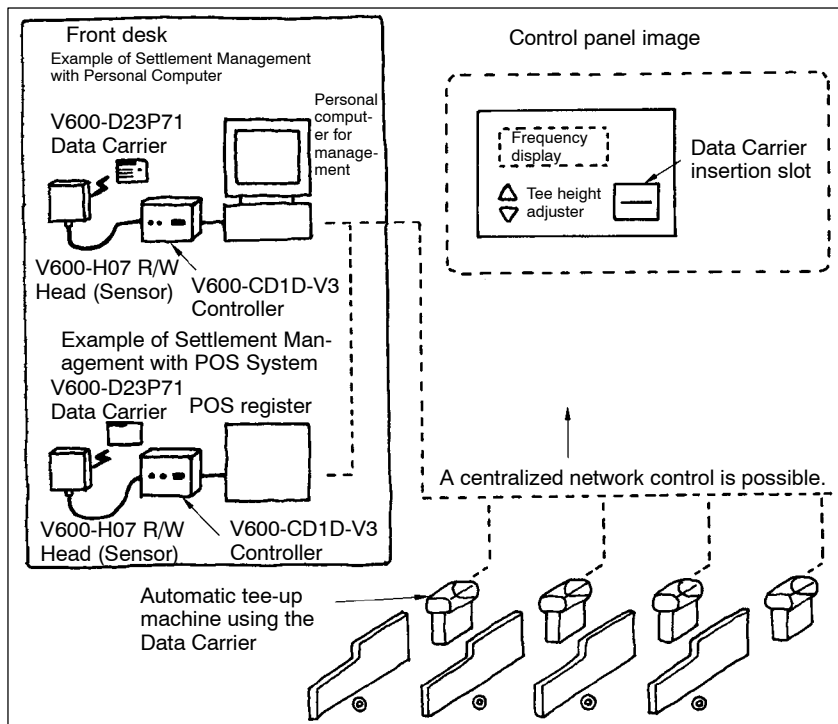

## Others

### Wireless Data Transmission

V600-D23P71 Data Carrier  
V600-H11 R/W Head (Sensor)  
C200H-IDS01-V1 ID Controller

- **Problem**

There is an optical transmission system that is not highly environment-resistive and cannot transmit a large quantity of data.

- **Solution**

Write data with the fixed Programmable Controller to the Data Carrier attached to the R/W Head.

The movable Programmable Controller reads the data in the Data Carrier.

- **Advantage**

This system uses an inductive-coupling method to transmit data has excellent environment durability.

A maximum of 245 bits (or 127 words) can be transmitted.

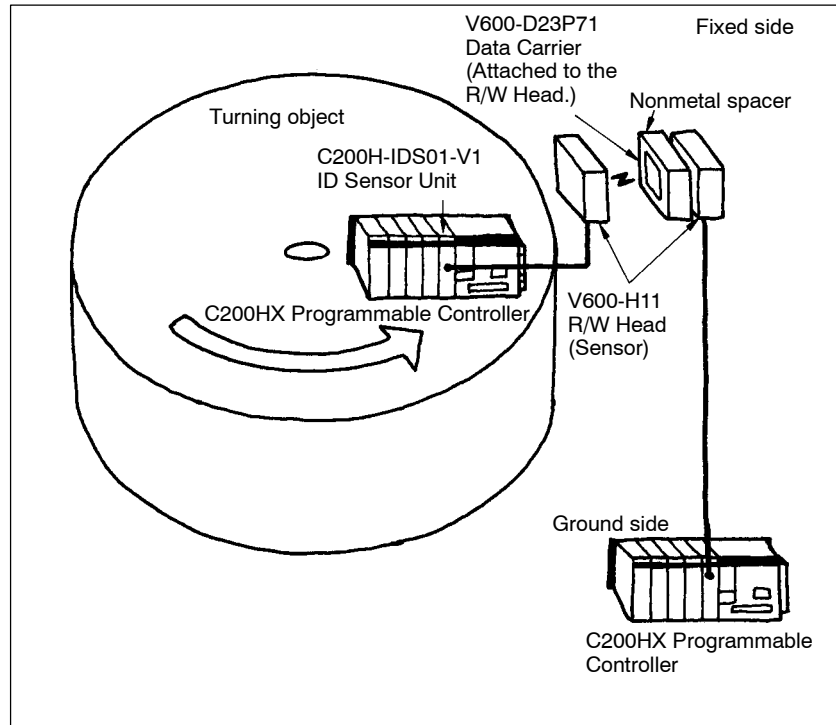

## Others

### Gas Bottle and Dangerous Chemical Management

V600-D23P53/54 Data Carrier  
V600-H52 R/W Head (Sensor)  
V600-CH1D-C Handheld Reader Writer

- **Problem**

Gas bottles must be inspected by law. There is a site where every gas bottle is stored with a bottle number tab. The management of the tabs is troublesome and on-site workers have difficulty finding required bottles.

- **Solution**

Provide each gas bottle with the Data Carrier that has necessary information on inspection, such as inspection date data.

- **Advantage**

The gas bottle can be checked by just reading the data from the Data Carrier.

The Data Carrier is embedded in the bolt on top of the gas bottle. Therefore, the Data Carrier can be removed or attached with ease.

Data can be written to and read from the Data Carrier in any location by using the Handheld Reader Writer.

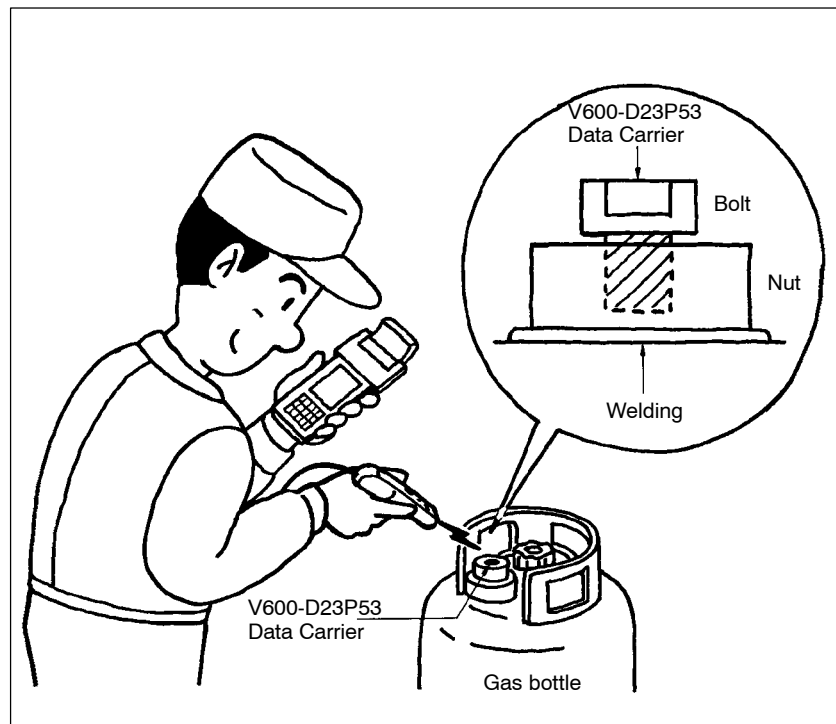



## OMRON ELECTRONICS LLC

1 Commerce Drive  
Schaumburg, IL 60173 USA  
800.55.OMRON (66766)

## OMRON CANADA, INC.

885 Milner Avenue  
Scarborough, Ontario M1B 5V8  
416.286.6465

## OMRON ON-LINE

Global - <http://www.omron.com>  
USA - <http://www.omron.com/oei>  
Canada - <http://www.omron.com/oci>

### UNITED STATES

To locate a Regional Sales Office, local Distributor or to obtain product information, call:

**800.55.OMRON or 847.843.7900**

### CANADA REGIONAL SALES OFFICES

<b>Ontario</b>	Toronto	416.286.6465
	Kitchener	519.896.1144
	Kingston	613.376.3968
<b>Quebec</b>	Montreal	514.636.6676
<b>British Columbia</b>	Vancouver	604.522.8855
<b>Alberta</b>	Edmonton	403.440.0818
	Calgary	403.257.3095

### BRAZIL SALES OFFICE

**Sao Paulo** 55.11.5564.6488

### ARGENTINA SALES OFFICE

**Buenos Aires** 54.11.4590.2408

### MEXICO SALES OFFICE - UNITED STATES

**Florida** 954.227.2121

### MEXICO SALES OFFICE - MEXICO

**Mexico, D.F.** 555.534.1195 **Monterrey, N.L.** 818.377.4281