

SYSMAC C-series/CVM1/CV-series Analog I/O Units

OPERATION MANUAL

OMRON

SYSMAC C-series/CVM1/CV-series Analog I/O Units

Operation Manual

Revised August 2007

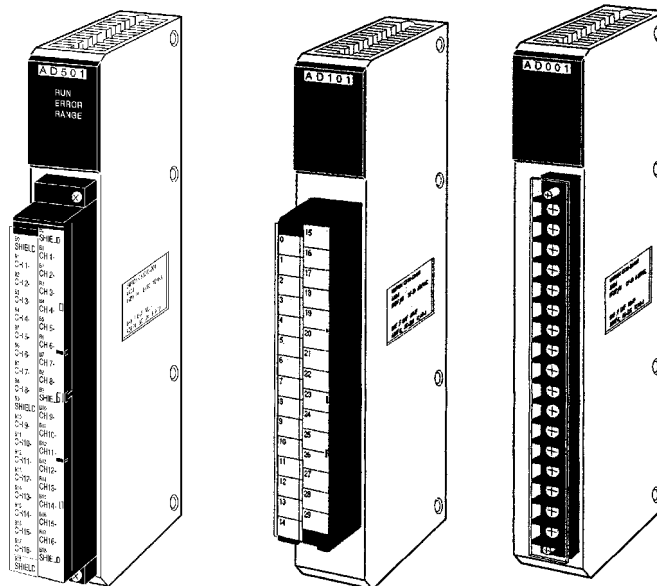



Notice:

OMRON products are manufactured for use according to proper procedures by a qualified operator and only for the purposes described in this manual.

The following conventions are used to indicate and classify precautions in this manual. Always heed the information provided with them. Failure to heed precautions can result in injury to people or damage to property.

 **DANGER** Indicates an imminently hazardous situation which, if not avoided, will result in death or serious injury. Additionally, there may be severe property damage.

 **WARNING** Indicates a potentially hazardous situation which, if not avoided, could result in death or serious injury. Additionally, there may be severe property damage.

 **Caution** Indicates a potentially hazardous situation which, if not avoided, may result in minor or moderate injury, or property damage.

OMRON Product References

All OMRON products are capitalized in this manual. The word “Unit” is also capitalized when it refers to an OMRON product, regardless of whether or not it appears in the proper name of the product.

The abbreviation “Ch,” which appears in some displays and on some OMRON products, often means “word” and is abbreviated “Wd” in documentation in this sense.

The abbreviation “PC” means Programmable Controller and is not used as an abbreviation for anything else.

Visual Aids

The following headings appear in the left column of the manual to help you locate different types of information.

Note Indicates information of particular interest for efficient and convenient operation of the product.

1, 2, 3... 1. Indicates lists of one sort or another, such as procedures, checklists, etc.

© OMRON, 1995

All rights reserved. No part of this publication may be reproduced, stored in a retrieval system, or transmitted, in any form, or by any means, mechanical, electronic, photocopying, recording, or otherwise, without the prior written permission of OMRON.

No patent liability is assumed with respect to the use of the information contained herein. Moreover, because OMRON is constantly striving to improve its high-quality products, the information contained in this manual is subject to change without notice. Every precaution has been taken in the preparation of this manual. Nevertheless, OMRON assumes no responsibility for errors or omissions. Neither is any liability assumed for damages resulting from the use of the information contained in this publication.

TABLE OF CONTENTS

PRECAUTIONS	XV
1 Intended Audience	xvi
2 General Precautions	xvi
3 Safety Precautions	xvi
4 Operating Environment Precautions	xvii
5 Application Precautions	xvii
6 Conformance to EC Directives	xix
SECTION 1	
Features and Basic Configuration	1
1-1 Features	2
1-2 Basic Configuration	5
SECTION 2	
3G2A5-AD001 to 3G2A5-AD005 Analog Input Units ...	7
2-1 Specifications and General Information	8
2-2 IR/CIO Bit Allocations	13
2-3 Functions and User Programming	14
SECTION 3	
3G2A5-AD006 and 3G2A5-AD007 Analog Input Units .	17
3-1 Specifications and General Information	18
3-2 IR/CIO Bit Allocations	23
3-3 Functions and User Programs	23
SECTION 4	
C500-AD101 Analog Input Unit	27
4-1 Specifications and General Information	28
4-2 Functions, Settings and Wiring	31
4-3 Two-word Operation	37
4-4 Four-word Operation	50
SECTION 5	
C500-AD501 Analog Input Unit	61
5-1 Specifications and General Information	62
5-2 Quick Start Procedure	69
5-3 Installation, Settings, and Wiring	70
5-4 Data Exchange with CPU Unit	76
5-5 Memory Map	80
5-6 Functions	87
5-7 User Programming Examples	94
SECTION 6	
3G2A5-DA001 to 3G2A5-DA005 Analog Output Units .	105
6-1 Specifications and General Information	106
6-2 IR/CIO Bit Allocations	110
6-3 Functions and User Programs	110
SECTION 7	
C500-DA101 Analog Output Unit	115
7-1 Specifications and General Information	116
7-2 IR/CIO Bit Allocations	122
7-3 Functions and User Programs	123

TABLE OF CONTENTS

SECTION 8

C500-DA103 Analog Output Unit 127

8-1 Specifications and General Information	128
8-2 IR/CIO Bit Allocations	132
8-3 Functions and User Programs	132

SECTION 9

C500-DA501 Analog Output Unit 135

9-1 Specifications and General Information	136
9-2 Settings and Wiring	147
9-3 Data Exchange with CPU Unit	153
9-4 Functions	175
9-5 User Programming Examples	182

Appendices

A DM Memory Coding Sheets	193
B Dimensions	207

Index 209

Revision History 213

About this Manual:

This manual describes the installation and operation of the C-series/CVM1/CV-series Analog I/O Units and includes the sections described below.

Please read this manual carefully and be sure you understand the information provided before attempting to install and operate the Analog I/O Units.

Section 1 provides a general introduction on the Analog I/O Units.

Section 2 provides information on 3G2A5-AD001 to 3G2A5-AD005 Analog Input Units including the specifications, connections, IR/CIO bit allocations, and applications.

Section 3 provides information on 3G2A5-AD006 and 3G2A5-AD007 Analog Input Units including the specifications, connections, IR/CIO bit allocations, and applications.

Section 4 provides information on the C500-AD101 Analog Input Unit including the specifications, connections, IR/CIO bit allocations, and applications for both two-word and four-word operation.

Section 5 provides information on the C500-AD501 Analog Input Unit including the specifications, connections, IR/CIO bit allocations, and applications.

Section 6 provides information on 3G2A5-DA001 to 3G2A5-DA005 Analog Output Units including the specifications, connections, IR/CIO bit allocations, and applications.

Section 7 provides information on the C500-DA101 Analog Output Unit including the specifications, connections, IR/CIO bit allocations, and applications.

Section 8 provides information on the C500-DA103 Analog Output Unit including the specifications, connections, IR/CIO bit allocations, and applications.

Section 9 provides information on the C500-DA501 Analog Output Unit including the specifications, connections, IR/CIO bit allocations, and applications.

Appendix A provides DM memory and memory map coding sheets for the C500-AD101 Analog Input Unit, the C500-AD501 Analog Input Unit, and the C500-DA501 Analog Output Unit. **Appendix B** provides the dimensions of the Analog I/O Units.



WARNING Failure to read and understand the information provided in this manual may result in personal injury or death, damage to the product, or product failure. Please read each section in its entirety and be sure you understand the information provided in the section and related sections before attempting any of the procedures or operations given.

Read and Understand this Manual

Please read and understand this manual before using the product. Please consult your OMRON representative if you have any questions or comments.

Warranty and Limitations of Liability

WARRANTY

OMRON's exclusive warranty is that the products are free from defects in materials and workmanship for a period of one year (or other period if specified) from date of sale by OMRON.

OMRON MAKES NO WARRANTY OR REPRESENTATION, EXPRESS OR IMPLIED, REGARDING NON-INFRINGEMENT, MERCHANTABILITY, OR FITNESS FOR PARTICULAR PURPOSE OF THE PRODUCTS. ANY BUYER OR USER ACKNOWLEDGES THAT THE BUYER OR USER ALONE HAS DETERMINED THAT THE PRODUCTS WILL SUITABLY MEET THE REQUIREMENTS OF THEIR INTENDED USE. OMRON DISCLAIMS ALL OTHER WARRANTIES, EXPRESS OR IMPLIED.

LIMITATIONS OF LIABILITY

OMRON SHALL NOT BE RESPONSIBLE FOR SPECIAL, INDIRECT, OR CONSEQUENTIAL DAMAGES, LOSS OF PROFITS OR COMMERCIAL LOSS IN ANY WAY CONNECTED WITH THE PRODUCTS, WHETHER SUCH CLAIM IS BASED ON CONTRACT, WARRANTY, NEGLIGENCE, OR STRICT LIABILITY.

In no event shall the responsibility of OMRON for any act exceed the individual price of the product on which liability is asserted.

IN NO EVENT SHALL OMRON BE RESPONSIBLE FOR WARRANTY, REPAIR, OR OTHER CLAIMS REGARDING THE PRODUCTS UNLESS OMRON'S ANALYSIS CONFIRMS THAT THE PRODUCTS WERE PROPERLY HANDLED, STORED, INSTALLED, AND MAINTAINED AND NOT SUBJECT TO CONTAMINATION, ABUSE, MISUSE, OR INAPPROPRIATE MODIFICATION OR REPAIR.

Application Considerations

SUITABILITY FOR USE

OMRON shall not be responsible for conformity with any standards, codes, or regulations that apply to the combination of products in the customer's application or use of the products.

At the customer's request, OMRON will provide applicable third party certification documents identifying ratings and limitations of use that apply to the products. This information by itself is not sufficient for a complete determination of the suitability of the products in combination with the end product, machine, system, or other application or use.

The following are some examples of applications for which particular attention must be given. This is not intended to be an exhaustive list of all possible uses of the products, nor is it intended to imply that the uses listed may be suitable for the products:

- Outdoor use, uses involving potential chemical contamination or electrical interference, or conditions or uses not described in this manual.
- Nuclear energy control systems, combustion systems, railroad systems, aviation systems, medical equipment, amusement machines, vehicles, safety equipment, and installations subject to separate industry or government regulations.
- Systems, machines, and equipment that could present a risk to life or property.

Please know and observe all prohibitions of use applicable to the products.

NEVER USE THE PRODUCTS FOR AN APPLICATION INVOLVING SERIOUS RISK TO LIFE OR PROPERTY WITHOUT ENSURING THAT THE SYSTEM AS A WHOLE HAS BEEN DESIGNED TO ADDRESS THE RISKS, AND THAT THE OMRON PRODUCTS ARE PROPERLY RATED AND INSTALLED FOR THE INTENDED USE WITHIN THE OVERALL EQUIPMENT OR SYSTEM.

PROGRAMMABLE PRODUCTS

OMRON shall not be responsible for the user's programming of a programmable product, or any consequence thereof.

Disclaimers

CHANGE IN SPECIFICATIONS

Product specifications and accessories may be changed at any time based on improvements and other reasons.

It is our practice to change model numbers when published ratings or features are changed, or when significant construction changes are made. However, some specifications of the products may be changed without any notice. When in doubt, special model numbers may be assigned to fix or establish key specifications for your application on your request. Please consult with your OMRON representative at any time to confirm actual specifications of purchased products.

DIMENSIONS AND WEIGHTS

Dimensions and weights are nominal and are not to be used for manufacturing purposes, even when tolerances are shown.

PERFORMANCE DATA

Performance data given in this manual is provided as a guide for the user in determining suitability and does not constitute a warranty. It may represent the result of OMRON's test conditions, and the users must correlate it to actual application requirements. Actual performance is subject to the OMRON Warranty and Limitations of Liability.

ERRORS AND OMISSIONS

The information in this manual has been carefully checked and is believed to be accurate; however, no responsibility is assumed for clerical, typographical, or proofreading errors, or omissions.

PRECAUTIONS

This section provides general precautions for using the Programmable Controller (PC) and Analog I/O Units.

The information contained in this section is important for the safe and reliable application of the Analog I/O Units. You must read this section and understand the information contained before attempting to set up or operate a PC system and Analog I/O Units.

1 Intended Audience	xvi
2 General Precautions	xvi
3 Safety Precautions	xvi
4 Operating Environment Precautions	xvii
5 Application Precautions	xvii
6 Conformance to EC Directives	xix

1 Intended Audience

This manual is intended for the following personnel, who must also have knowledge of electrical systems (an electrical engineer or the equivalent).

- Personnel in charge of installing FA systems
- Personnel in charge of designing FA systems
- Personnel in charge of managing FA systems and facilities

2 General Precautions

The user must operate the product according to the performance specifications described in the operation manuals.

Before using the product under conditions which are not described in the manual or applying the product to nuclear control systems, railroad systems, aviation systems, vehicles, combustion systems, medical equipment, amusement machines, safety equipment, and other systems, machines, and equipment that may have a serious influence on lives and property if used improperly, consult your OMRON representative.

Make sure that the ratings and performance characteristics of the product are sufficient for the systems, machines, and equipment, and be sure to provide the systems, machines, and equipment with double safety mechanisms.

This manual provides information for programming and operating OMRON Analog I/O Units. Be sure to read this manual before attempting to use the software and keep this manual close at hand for reference during operation.

 **WARNING** It is extremely important that a PC and all PC Units be used for the specified purpose and under the specified conditions, especially in applications that can directly or indirectly affect human life. You must consult with your OMRON representative before applying a PC System to the above-mentioned applications.

3 Safety Precautions



 **WARNING** Do not attempt to take any Unit apart while power is being supplied. Doing so may result in electric shock.

 **WARNING** Do not touch any of the terminals or terminal blocks while power is being supplied. Doing so may result in electric shock.

 **Caution** Tighten the screws on the terminal block of the AC Power Supply Unit to the torque specified in the operation manual. The loose screws may result in burning or malfunction.



 **Caution** Confirm safety at the destination node before transferring a program to another node or changing contents of the I/O memory area. Doing either of these without confirming safety may result in injury.

4 Operating Environment Precautions

-  **Caution** Do not operate the control system in the following places:
- Locations subject to direct sunlight.
 - Locations subject to temperatures or humidity outside the range specified in the specifications.
 - Locations subject to condensation as the result of severe changes in temperature.
 - Locations subject to corrosive or flammable gases.
 - Locations subject to dust (especially iron dust) or salts.
 - Locations subject to exposure to water, oil, or chemicals.
 - Locations subject to shock or vibration.
-  **Caution** Take appropriate and sufficient countermeasures when installing systems in the following locations:
- Locations subject to static electricity or other forms of noise.
 - Locations subject to strong electromagnetic fields.
 - Locations subject to possible exposure to radioactivity.
 - Locations close to power supplies.
-  **Caution** The operating environment of the PC System can have a large effect on the longevity and reliability of the system. Improper operating environments can lead to malfunction, failure, and other unforeseeable problems with the PC System. Be sure that the operating environment is within the specified conditions at installation and remains within the specified conditions during the life of the system.

5 Application Precautions

Observe the following precautions when using the PC.

-  **WARNING** Always heed these precautions. Failure to abide by the following precautions could lead to serious or possibly fatal injury.
- Always connect to a ground of 100 Ω or less when installing the Units. Not connecting to a ground of 100 Ω or less may result in electric shock.
 - Always turn off the power supply to the PC before attempting any of the following. Not turning off the power supply may result in malfunction or electric shock.
 - Mounting or dismounting Power Supply Units, I/O Units, CPU Units, Memory Cassettes, or any other Units.
 - Assembling the Units.
 - Setting DIP switch or rotary switches.
 - Connecting or wiring the cables.
 - Connecting or disconnecting the connectors.
-  **Caution** Failure to abide by the following precautions could lead to faulty operation of the PC or the system, or could damage the PC or PC Units. Always heed these precautions.
- Fail-safe measures must be taken by the customer to ensure safety in the event of incorrect, missing, or abnormal signals caused by broken signal lines, momentary power interruptions, or other causes.

- Interlock circuits, limit circuits, and similar safety measures in external circuits (i.e., not in the Programmable Controller) must be provided by the customer.
- Always use the power supply voltage specified in this manual. An incorrect voltage may result in malfunction or burning.
- Take appropriate measures to ensure that the specified power with the rated voltage and frequency is supplied. Be particularly careful in places where the power supply is unstable. An incorrect power supply may result in malfunction.
- Install external breakers and take other safety measures against short-circuiting in external wiring. Insufficient safety measures against short-circuiting may result in burning.
- Do not apply voltages to the Input Units in excess of the rated input voltage. Excess voltages may result in burning.
- Do not apply voltages or connect loads to the Output Units in excess of the maximum switching capacity. Excess voltage or loads may result in burning.
- Disconnect the functional ground terminal when performing withstand voltage tests. Not disconnecting the functional ground terminal may result in burning.
- Do not attempt to disassemble, repair, or modify any Units.
- Tighten screws on the terminal block to a torque of 0.8 N • m. Incorrect tightening torque may result in malfunction.
- Be careful not to allow wire cuttings to enter inside the Unit when wiring. Allowing wire cuttings inside the Unit may result in malfunction.
- Use crimp terminals for wiring. Do not connect bare stranded wires directly to terminals. Connection of bare stranded wires may result in burning.
- Double-check all the wiring before turning on the power supply. Incorrect wiring may result in burning.
- Mount the Unit only after checking the terminal block completely.
- Be sure that the terminal blocks, Memory Units, expansion cables, and other items with locking devices are properly locked into place. Improper locking may result in malfunction.
- Check the user program for proper execution before actually running it on the Unit. Not checking the program may result in an unexpected operation.
- Confirm that no adverse effect will occur in the system before attempting any of the following. Not doing so may result in an unexpected operation.
 - Changing the operating mode of the PC.
 - Force-setting/force-resetting any bit in memory.
 - Changing the present value of any word or any set value in memory.
- Resume operation only after transferring to the new CPU Unit the contents of the DM Area, HR Area, and other data required for resuming operation. Not doing so may result in an unexpected operation.
- Do not pull on the cables or bend the cables beyond their natural limit. Doing either of these may break the cables.
- Do not place objects on top of the cables or other wiring lines. Doing so may break the cables.
- Before touching the Unit, be sure to first touch a grounded metallic object in order to discharge any static built-up. Not doing so may result in malfunction or damage.
- When replacing parts, be sure to confirm that the rating of a new part is correct. Not doing so may result in malfunction or burning.

6 Conformance to EC Directives

Applicable Directives

- EMC Directives
- Low Voltage Directive

Concepts

EMC Directives

OMRON supplies electric devices that are used built into other devices or manufacturing equipment. These OMRON products are designed to conform to the related EMC standards (see note) so that the devices or equipment in which they are used can more easily conform to EMC standards.

EMC-related performance of the OMRON devices that conform to EC Directives will vary depending on the configuration, wiring, and other conditions of the equipment or control panel on which the OMRON devices are installed. The customer must, therefore, perform the final check to confirm that devices and the overall machine conform to EMC standards.

Note Applicable EMC (Electromagnetic Compatibility) standards are as follows: EN 61131-2

Low Voltage Directive

Always ensure that devices operating at voltages of 50 to 1,000 V AC and 75 to 1,500 V DC meet the required safety standards for the PLC (EN 61131-2).

Conformance to EC Directives

CV-series products conform to EC Directives (see note). However, the following precautions must be observed to ensure that the machine or device in which the CV-series PLC is used conforms to EC Directives:

1. The CV-series PLC must be installed within a control panel.
2. You must use reinforced insulation or double insulation for the DC power supplies connected to the power supply terminals on PLCs that take DC power and for the DC power supplies connected to I/O Units. The DC power supply connected to the power supply terminals on PLCs using DC power must have an output hold time of at least 10 ms.
3. CV-series products conforming to EC Directives also conform to EN 61131-2 for EMI. Radiated emission characteristics (10-m regulations) may vary depending on the configuration of the control panel used, other devices connected to the control panel, wiring, and other conditions. You must therefore confirm that the overall machine or equipment conforms to EC Directives even when using CV-series products that conform to EC Directives.

Note Of the products that appear in this manual, the following products conform to EC Directives.

C500H-AD101 Analog Input Unit
C500H-DA101 Analog Output Unit

SECTION 1

Features and Basic Configuration

This section provides a general introduction on the Analog I/O Units.

1-1	Features	2
1-1-1	Analog Input Units	2
1-1-2	Analog Output Units	3
1-2	Basic Configuration	5

1-1 Features

1-1-1 Analog Input Units

This operation manual describes the features of the following Analog Input Units.

- 3G2A5-AD001 to 3G2A5-AD007
- C500-AD101
- C500-AD501

Basic Function

Analog quantities, such as temperature, pressure, power, and power factor, input to an Analog Input Unit via a preamplifier or transducer are converted to digital values for input to the CPU Unit.

Features

3G2A5-AD001 to 3G2A5-AD007

Analog signals from sensors are converted to 12-bit binary data by the 3G2A5-AD001 to 3G2A5-AD005 Analog Input Units (resolution: 1/4095); or to 10-bit binary data by the 3G2A5-AD006 and 3G2A5-AD007 Analog Input Units (resolution: 1/1023).

Number of Input Points Per Unit

Each Unit can handle A/D conversion for either two or four input points.

Unit	Number of Inputs
3G2A5-AD001 to 3G2A5-AD005	2 points
3G2A5-AD006/007	4 points

Compatible Input Specifications

The Units are compatible with a variety of input specifications. Select the appropriate Unit from the table below.

Input signal range		Unit
Voltage	1 to 5 V	3G2A5-AD001/006
	0 to 10 V	3G2A5-AD002/007
	0 to 5 V	3G2A5-AD003
	-10 to 10 V	3G2A5-AD004
	-5 to 5 V	3G2A5-AD005
Current	4 to 20 mA	3G2A5-AD001/006

C500-AD101

This Unit converts analog signals from sensors to 12-bit binary data.

Number of Input Points Per Unit

Each Unit has eight input points. An separate input signal range can be set for each input point, to permit the simultaneous use of sensors with different output forms.

Input Signal Ranges

The input signal ranges can be set as required between 0 and 10 V for a voltage input or between 0 and 20 mA for a current input.

Many Features

In addition to A/D conversion, the Analog Input Units offer peak hold, mean value, scaling, and disconnection detection functions.

High Accuracy and High Speed

The C500-AD101 achieves a resolution up to 1/4095 and a conversion time of 10 ms max. per point.

The I/O READ and I/O WRITE instructions, READ and WRIT, can be used to transfer data with the CPU Unit, thereby simplifying program creation and achieving high-speed processing with batch transfer.

C500-AD501

This Analog Input Unit converts analog voltage or current signals from sensors to signed BCD data or to binary data (with two's complements used for negative values). A microprocessor is built into the C500-AD501 to enable advanced data processing in the Analog Input Unit before transferring the data to the CPU Unit.

Number of Input Points Per Unit

Each Unit has sixteen input points. An separate input signal range can be set for each input point, to permit the simultaneous use of sensors with different output forms.

Input Signal Ranges

The input signal ranges can be set as required as follows:

Voltage inputs: 0 to 5 V, 0 to 10 V, -5 to 5 V, or -10 to 10 V

Current inputs: 0 to 20 mA or -20 to 20 mA

Many Features

In addition to A/D conversion, the Analog Input Units offer scaling, filtering, averaging, peak hold, upper/lower limits, and input range high/low alarms. These functions can be set separately for each input point. Executing these function in the Analog Input Unit greatly reduces the load on the ladder program and the CPU Unit.

High Accuracy and High Speed

The C500-AD501 achieves a resolution up to 1/4095 and a conversion time of 25 ms max. per 16 input points. (The use of the above special function will increase the conversion time.)

The I/O READ and I/O WRITE instructions, READ and WRIT, can be used to transfer data with the CPU Unit, thereby simplifying program creation and achieving high-speed processing with batch transfer. A Pointer Word can also be set to limit the words being read or written to further increase speed.

Built-in EEPROM

An EEPROM is built into the C500-AD501 to enable storing parameters. The parameters stored in EEPROM are transferred to RAM at the start of operation before beginning actual operation.

1-1-2 Analog Output Units

This operation manual describes the features of the following Analog Output Units.

- 3G2A5-DA001 to 3G2A5-DA005
- C500-DA101/103
- C500-DA501

Basic Function

Conversion of PC digital output signals to analog signals to drive instruments and devices requiring an analog input.

Features

**3G2A5-DA001 to
3G2A5-DA005**

These Units convert 12-bit binary data with a resolution of 1/4095 to analog signals.

Number of Output Points Per Unit

Each Unit can handle D/A conversion for two output points.

Output Specifications

The Units are compatible with a variety of output specifications. Select the appropriate Unit from the table below.

Output signal range		Unit
Voltage	1 to 5 V	3G2A5-DA001
	0 to 10 V	3G2A5-DA002
	0 to 5 V	3G2A5-DA003
	-10 to 10 V	3G2A5-DA004
	-5 to 5 V	3G2A5-DA005
Current	4 to 20 mA	3G2A5-DA001

C500-DA101/103

The C500-DA101 converts 12-bit binary data and the C500-DA103 converts binary data with 1 sign bit + 11 data bits to analog output signals, with resolution of 1/4095 in each case.

Number of Output Points Per Unit

Each Unit can handle D/A conversion for four output points.

A separate output signal range can be set for each C500-DA101 output point.

Output Specifications

The C500-DA101 can be set to one of the three output signal ranges shown in the table below.

Output signal range		Unit
Voltage	1 to 5 V	C500-DA101
	0 to 10 V	
	-10 to 10 V	C500-DA103
Current	4 to 20 mA	C500-DA101

C500-DA501

The C500-DA501 converts 12-bit binary/BCD data or binary/BCD data with 1 sign bit + 11 data bits to analog output signals, with resolution of 1/4095 in each case.

Number of Output Points Per Unit

Each Unit can handle D/A conversion for eight output points.

A separate output signal range can be set for each C500-DA501 output point.

Output Specifications

Each output point for the C500-DA501 can be set to one of the output signal ranges shown in the following table.

Output signal range		Unit
Voltage	0 to 10 V	C500-DA501
	0 to 5 V	
	-5 to 5 V	
	-10 to 10 V	
Current	0 to 20 mA	C500-DA501
	4 to 20 mA	

BCD or binary can be selected as the output data for each output point.

The scaling function can be set for each output point.

The upper/lower limit function can be set for each output point.

The output ramp function can be set for each output point.

High-speed D/A conversion can be set for all eight output points.

1-2 Basic Configuration

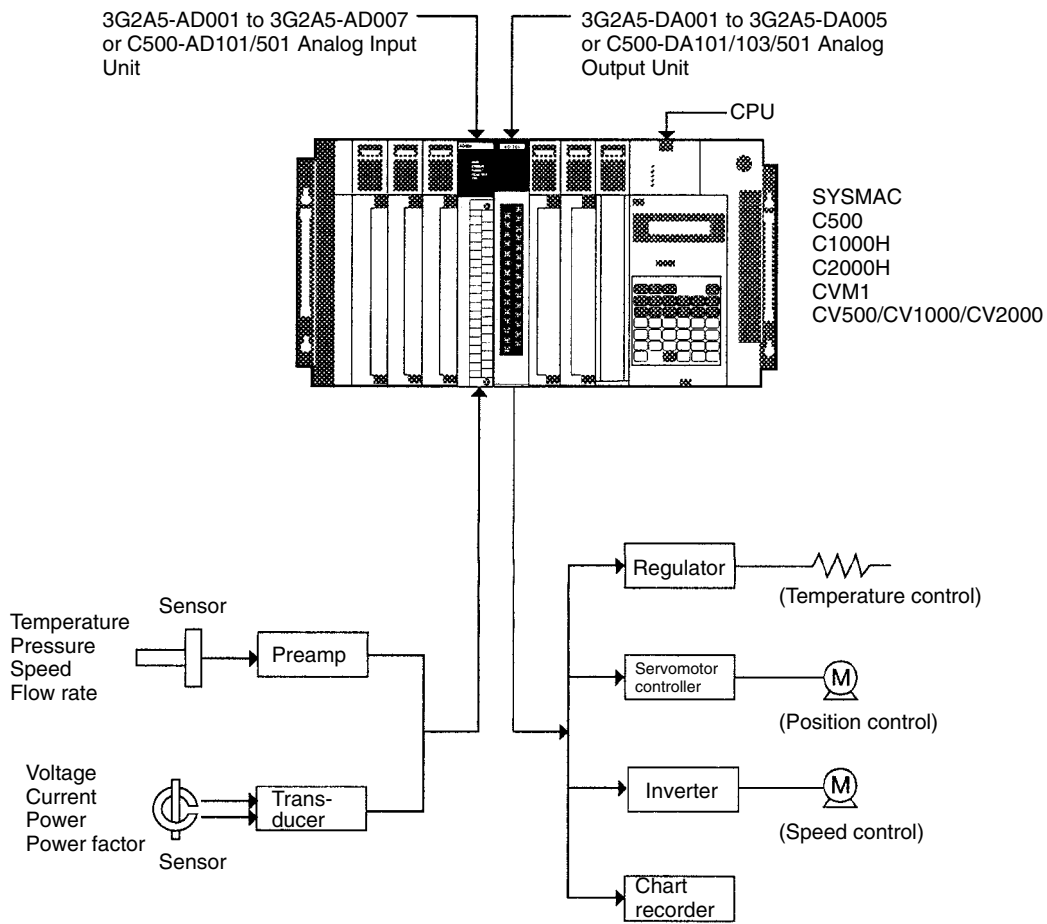

The diagram above shows the C500-AD501 and C500-DA101 as examples of Analog I/O Units.

Example Configurations

Temperature Regulating System

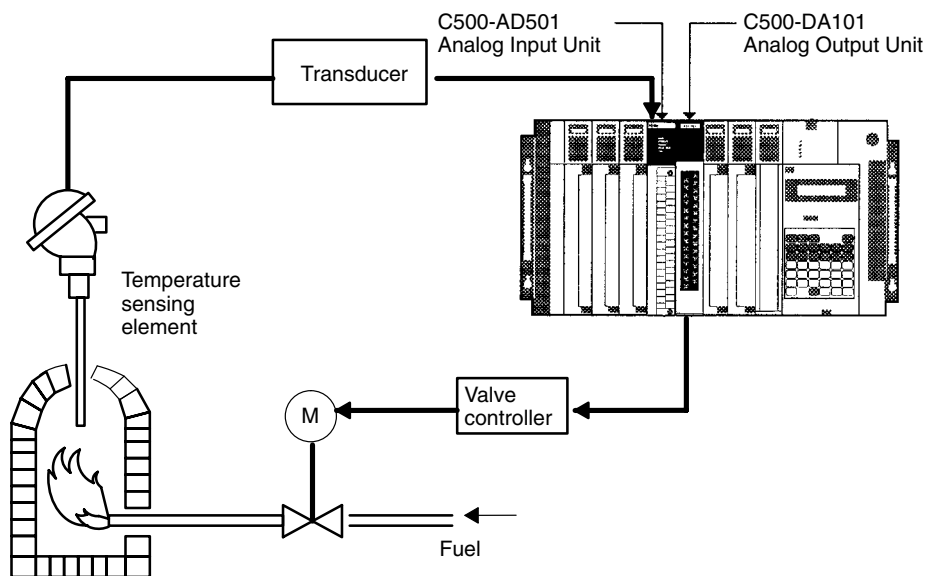

Servomotor Positioning System

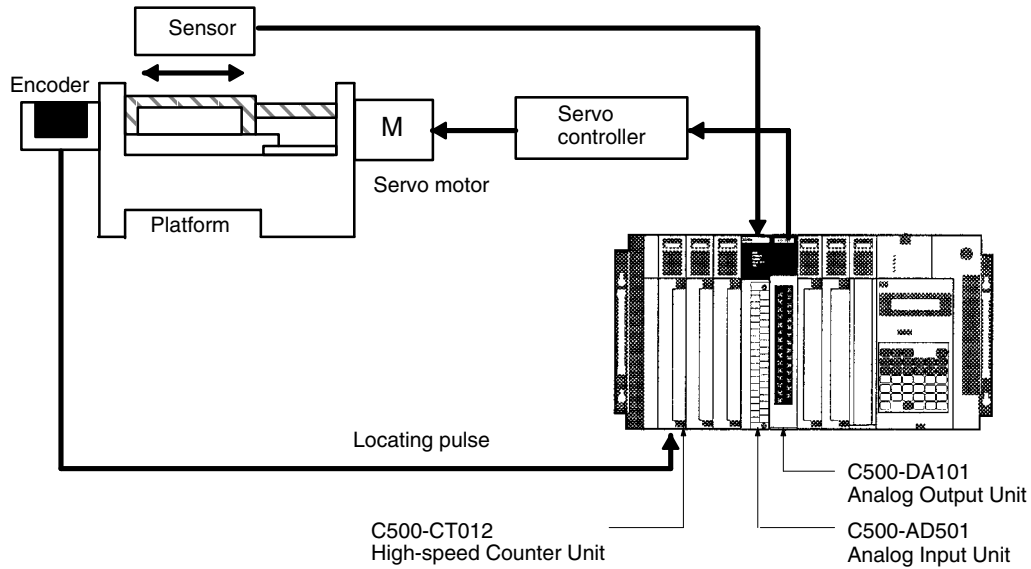

The diagram above shows the C500-AD501 and C500-DA101 as examples of Analog I/O Units.

! Caution System Configuration

The I/O READ and I/O WRITE instructions (READ and WRIT) cannot be used for Units mounted to SYSMAC BUS Slave Racks. Set the C500-AD101 or C500-DA501 for four-word operation whenever they are mounted to a SYSMAC BUS Slave Rack. The C500-AD501 can operate only through the READ and WRIT instructions and therefore cannot be mounted on a SYSMAC BUS Slave Rack.

Rack	READ/WRIT instruction
CPU Rack, Expansion I/O Rack, SYSMAC BUS/2 Slave Rack	Can be used.
SYSMAC BUS Slave Rack	Cannot be used.

! Caution Using the Units

Turn OFF the PC power supply before connecting or disconnecting Units or wiring. To reduce noise problems, wire the input and output lines through a duct separate from the high-voltage and power cables. Refer to *Wiring* in the section on the relevant Unit for detailed information and cautions on wiring.

SECTION 2

3G2A5-AD001 to 3G2A5-AD005 Analog Input Units

This section provides information on 3G2A5-AD001 to 3G2A5-AD005 Analog Input Units including the specifications, connections, IR/CIO bit allocations, and applications.

2-1	Specifications and General Information	8
2-1-1	Specifications	8
2-1-2	Description of Parts	9
2-1-3	Block Diagram	10
2-1-4	Wiring	11
2-2	IR/CIO Bit Allocations	13
2-3	Functions and User Programming	14
2-3-1	Input Signals and Converted Data	14
2-3-2	Ladder Programming Example	15

2-1 Specifications and General Information

2-1-1 Specifications

General Specifications

All general specifications of the 3G2A5-AD001 through 3G2A5-AD005 Analog Input Units conform to those of the C Series, except the following.

- Insulation between the External Terminals and the Frame:
5M Ω min. at 250 VDC
- Breakdown Voltage between the External Terminals and the Frame:
500 VAC, 50-60 Hz for 1 minute

Performance Specifications

Item	Specification		
Number of analog inputs	2		
Input signal range	Voltage input	AD001	1 to 5 V
		AD002	0 to 10 V
		AD003	0 to 5 V
		AD004	-10 to 10 V
		AD005	-5 to 5 V
	Current input	AD001	4 to 20 mA
Max. input signal	Voltage input	± 15 V max.	
	Current input	± 60 mA max.	
External input impedance	Voltage input	1 M Ω min.	
	Current input	250 Ω	
Resolution	1/4095 (full scale)		
PC signal (see note 1)	12-bit binary		
Linearity error	$\pm 0.1\%$ max.		
Accuracy	$\pm 0.2\%$ max. (full scale at 25°C)		
Accuracy temperature coefficient	± 100 PPM/°C (full scale)		
Conversion time	2.5 ms max./point		
Conversion cycle	5 ms max.		
Max. PC write delay (see note 2)	1 s max.		
Conversion method	Sequential comparison		
Words allocated	2 input words		
External connections	17-pin terminal block (not removable)		
Power consumption	500 mA max. at 5 VDC		
External dimensions	34.5 x 250 x 113 mm (W x H x D)		
Weight	600 g max.		

- Note**
1. A sign bit + 11 data bits binary data for Units with -10 to 10 V and -5 to 5 V range (3G2A5-AD004 and 3G2A5-AD005).
 2. The PC write delay is the time required for a change in the input signal to be converted and transferred to the PC bus.

PC Write Delay

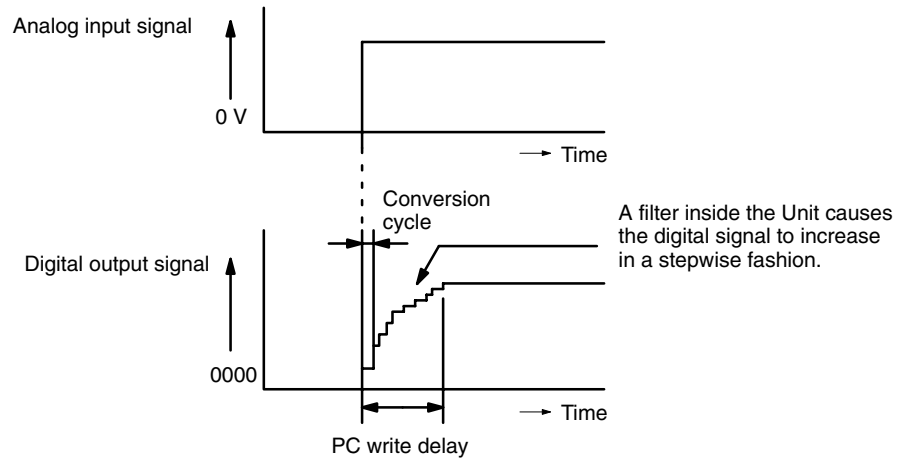

2-1-2 Description of Parts

3G2A5-AD001 to 3G2A5-AD005

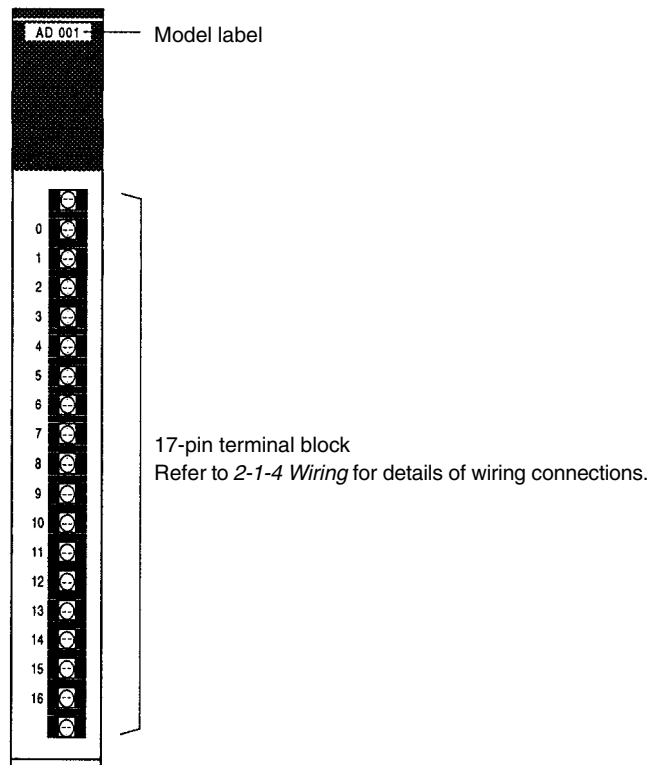

2-1-3 Block Diagram

The following diagram shows the basic internal connections of the Unit.

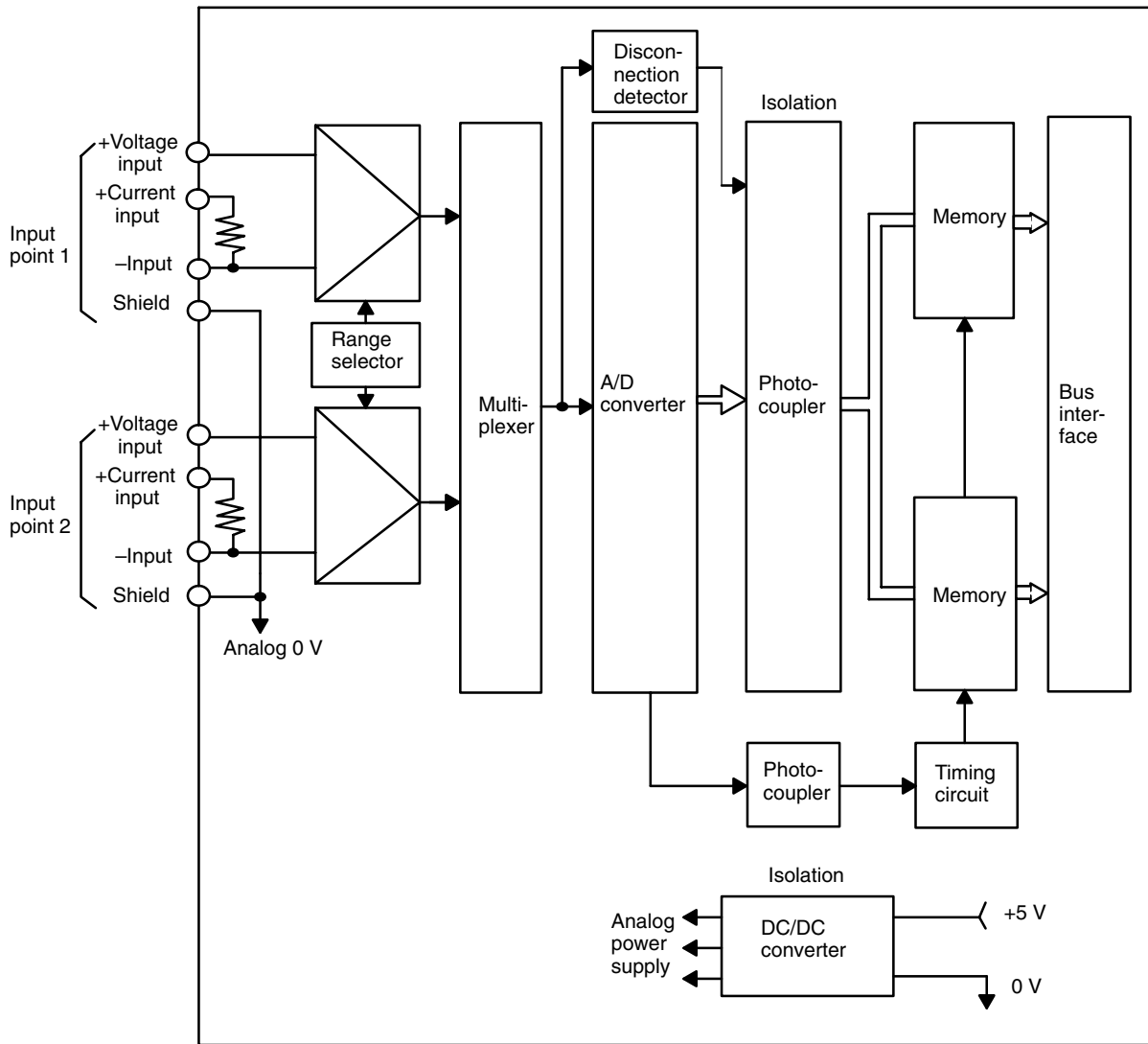

Note Disconnection detection for input signal specifications 1 to 5 V, 4 to 20 mA range (3G2A5-AD001) only.

2-1-4 Wiring

Voltage Inputs

1, 2, 3... 1. Common Mode Input Signals

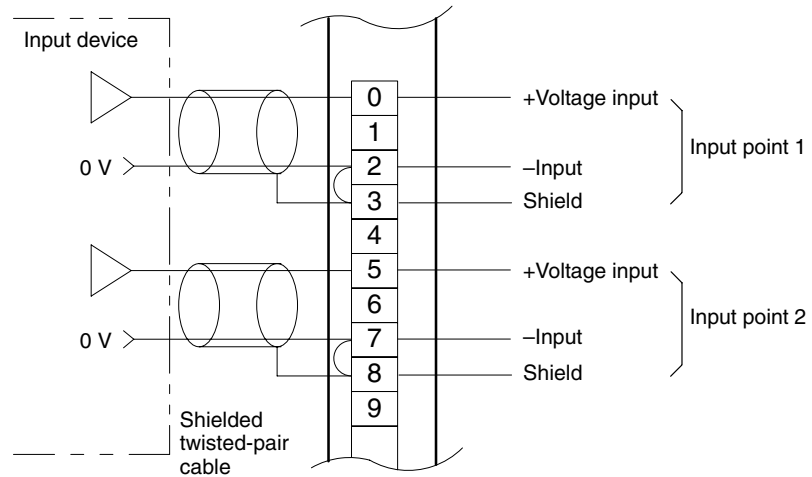

2. Differential Output Signals

Separate power supplies for input points 1 and 2 are used.

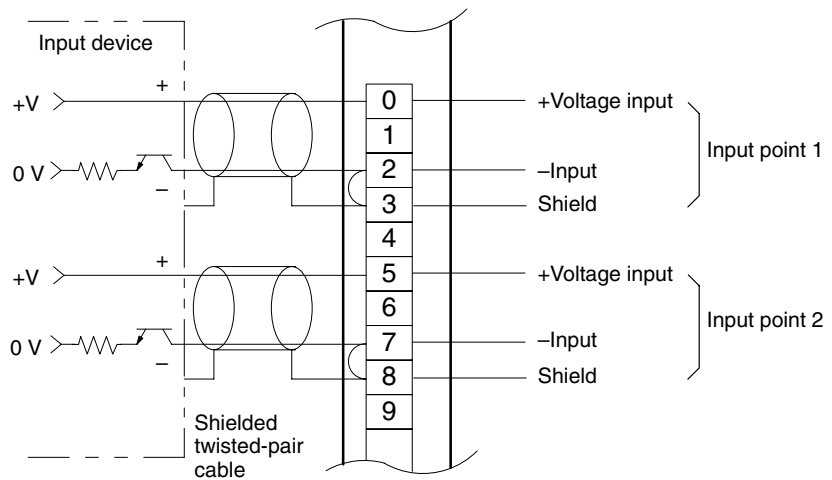

Current Inputs

Separate power supplies for input points 1 and 2 are used.

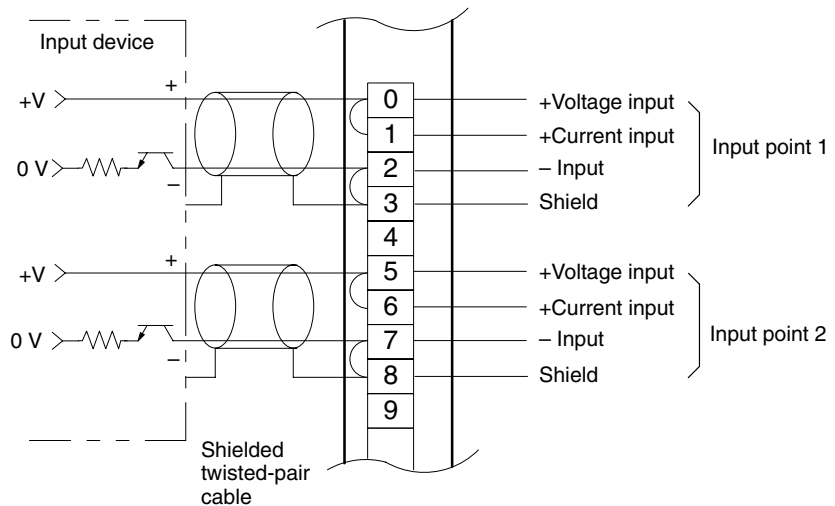

Precautions

Abide by the following precautions when using separate power supplies for the input points.

- 1, 2, 3... 1. Use shielded twisted-pair cable for external connections.
2. Connect the positive and negative terminals of any unused input points to the shield terminal.
3. Use separate power supplies for input points 1 and 2 whenever possible. In this case, the shield terminal must be shorted to the negative terminal, as shown in the diagrams above. Failure to do so may cause errors of several percent in the output data.
4. If the same power supply must be used for input points 1 and 2, connect the wiring as shown in the diagram below.

The connections shown in the previous diagrams should not be used for a single power supply, because the internal connections of the shield terminals for input points 1 and 2 inside the Unit cause interference between the input points and inaccurate data will result.

Connect as shown in previous diagram (1) for voltage input signals in common mode.

Voltage Input and Differential Output Signals

Connect according to one of the following methods when the same power supply is used for input points 1 and 2.

- 1, 2, 3... 1. Connect shield terminal to signal supply common terminal.

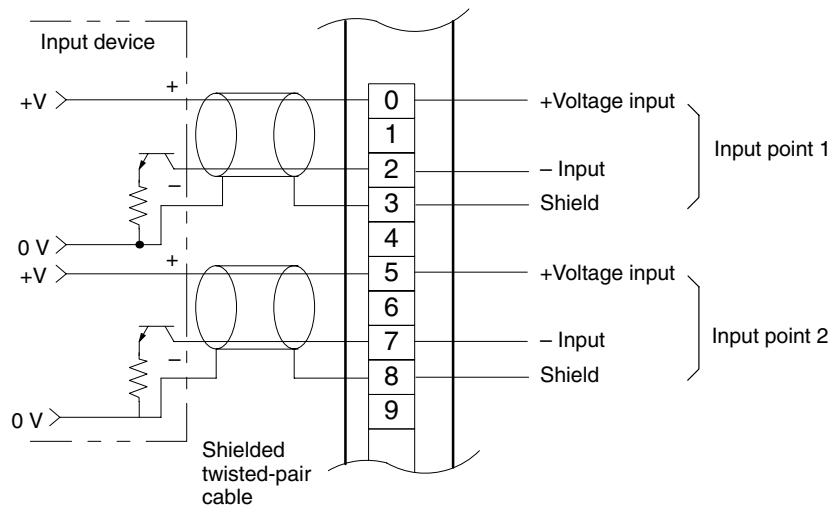

2. Connect resistors from the shield to the positive and negative terminals.

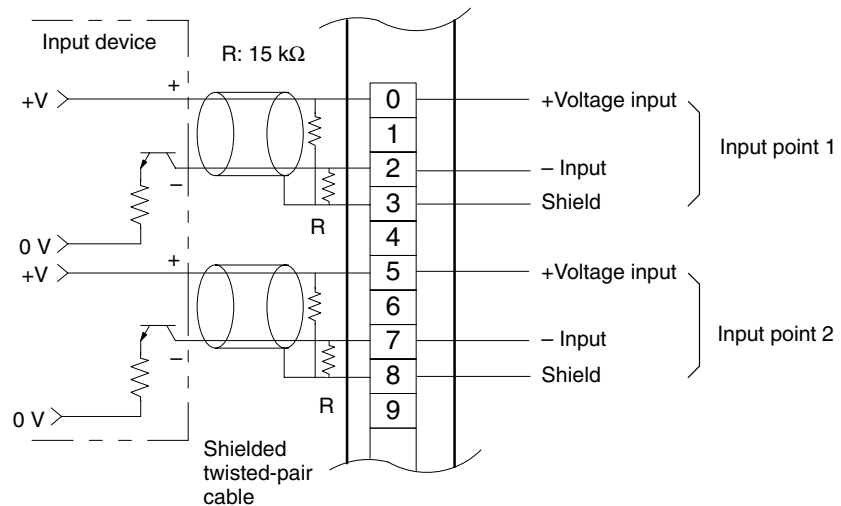

Current Input

Connect as shown below when the same power supply is used for input points 1 and 2.

Connect resistors from the shield to the negative terminal. This connection results in an accuracy of $\pm 1\%$.

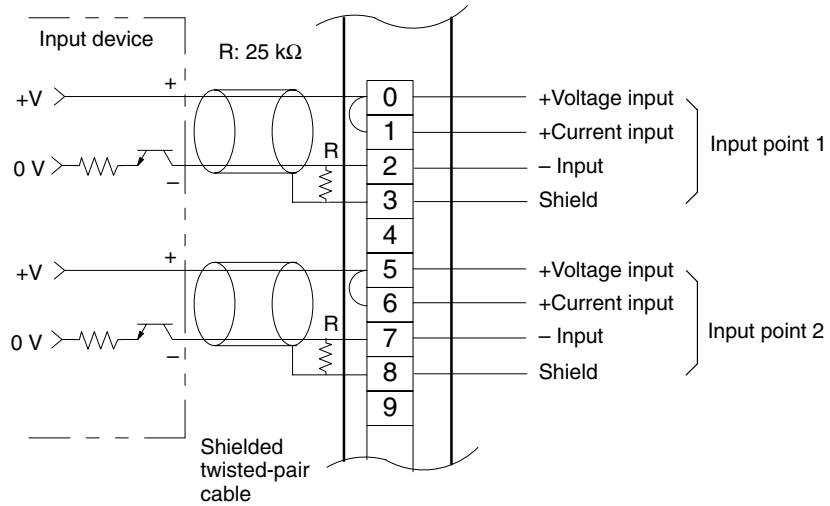

Precaution

Abide by the following precaution when the same power supply is used for the input points.

Connect the wiring as shown in the diagram above when the same power supply is used for input points 1 and 2.

Note Unlike when separate power supplies are used, the shield terminal must not be shorted to the negative terminal.

2-2 IR/CIO Bit Allocations

The IR/CIO bit allocations are shown below. Each Unit is allocated two words.

Bit	Input words	
	IR/CIO n: Point 1	IR/CIO n+1: Point 2
0	A/D converted data 2^0	A/D converted data 2^0
1	A/D converted data 2^1	A/D converted data 2^1
2	A/D converted data 2^2	A/D converted data 2^2
3	A/D converted data 2^3	A/D converted data 2^3
4	A/D converted data 2^4	A/D converted data 2^4
5	A/D converted data 2^5	A/D converted data 2^5
6	A/D converted data 2^6	A/D converted data 2^6
7	A/D converted data 2^7	A/D converted data 2^7
8	A/D converted data 2^8	A/D converted data 2^8
9	A/D converted data 2^9	A/D converted data 2^9
10	A/D converted data 2^{10}	A/D converted data 2^{10}
11 (See note 1)	A/D converted data 2^{11}	A/D converted data 2^{11}
12	0	0
13	0	0
14	0	0
15 (See note 2)	Disconnection detect bit	Disconnection detect bit

Note 1. The function of bit 11 differs for a unipolar and bipolar input, as follows:
 Unipolar Input: A/D Converted Data: 2^{11}
 Bipolar Input: Sign Bit: OFF for positive values
 ON for negative values

2. The disconnection detection bit operates for input signal specifications 1 to 5 V, 4 to 20 mA ranges (3G2A5-AD001) only.

ON: Disconnection
 OFF: Normal

Detection Level

1 to 5 V Range: Detected at 0.5 V
 4 to 20 mA Range: Detected at 2 mA

Always OFF in other ranges.

2-3 Functions and User Programming

2-3-1 Input Signals and Converted Data

The Analog Input Unit converts analog input signals into digital data. Five models are available to support different analog input ranges. The analog input signals can be unipolar inputs which are positive, or bipolar inputs which are positive and negative. The resolution differs according to the input range.

Unipolar Input

Input Ranges: 1 to 5 V 3G2A5-AD001
 4 to 20 mA 3G2A5-AD001
 0 to 10 V 3G2A5-AD002
 0 to 5 V 3G2A5-AD003

Converted Output: A/D converted data, 12-bit binary data

Note Bit 15 for the 1 to 5 V, 4 to 20 mA ranges (3G2A5-AD001) is the connection detection bit.

ON: Disconnection
 OFF: Normal

The detection levels are as follows.

1 to 5 V Range: Detected at 0.5 V max.
 4 to 20 mA Range: Detected at 2 mA max.

Relationship Between Input Signals and A/D Conversion Data

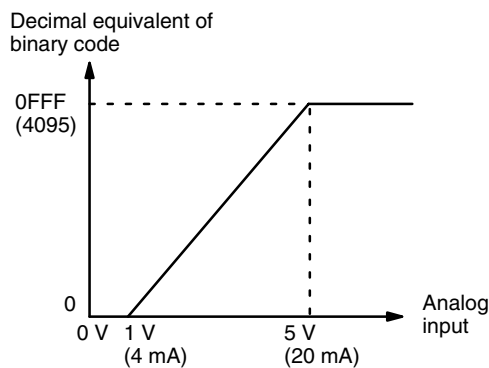

Input: 1 to 5 V, 4 to 20 mA

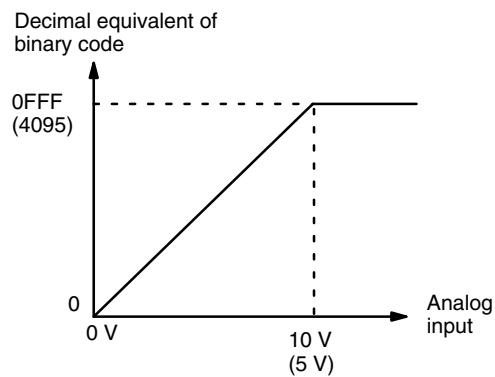

Input: 0 to 10 V, 0 to 5 V

Bipolar Input

Input Ranges: -10 to 10 V 3G2A5-AD004
 -5 to 5 V 3G2A5-AD005

Converted Output: 1 sign bit + 11 A/D converted data bits

Bit 11 is the sign bit: OFF for positive values
 ON for negative values

Relationship Between Input Signals and A/D Conversion Data

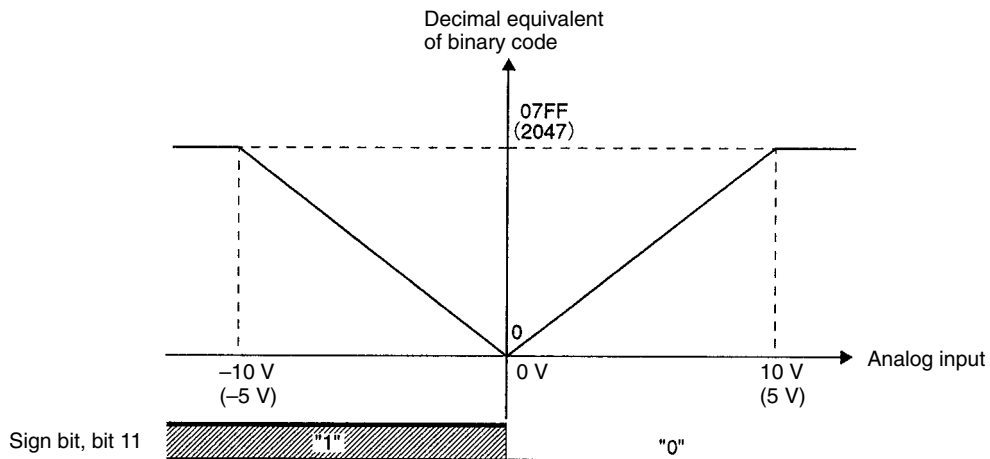

2-3-2 Ladder Programming Example

The following example program uses a 1 to 5 V input-range Analog Input Unit to convert two different analog input signals to 4-digit BCD values (4,095 maximum) and outputs the result.

Connections

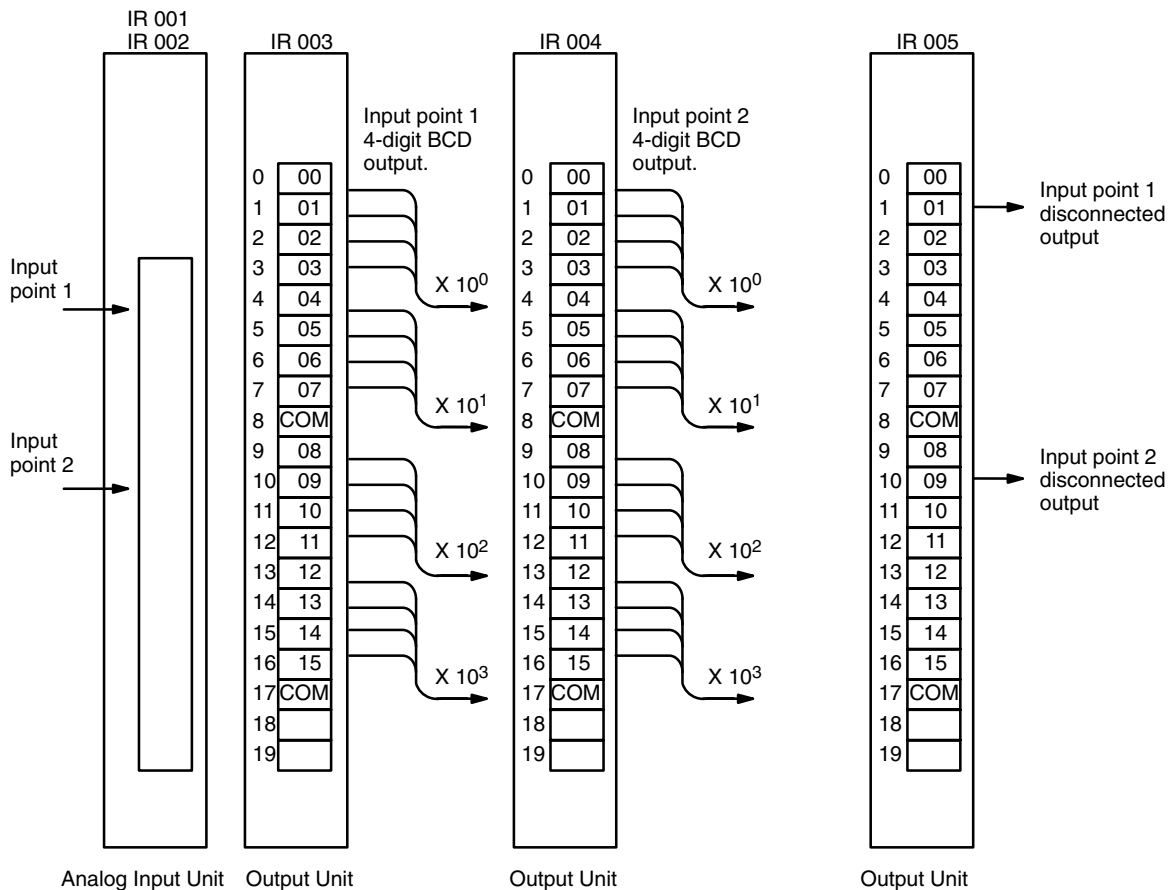

Programming Example for the C1000H

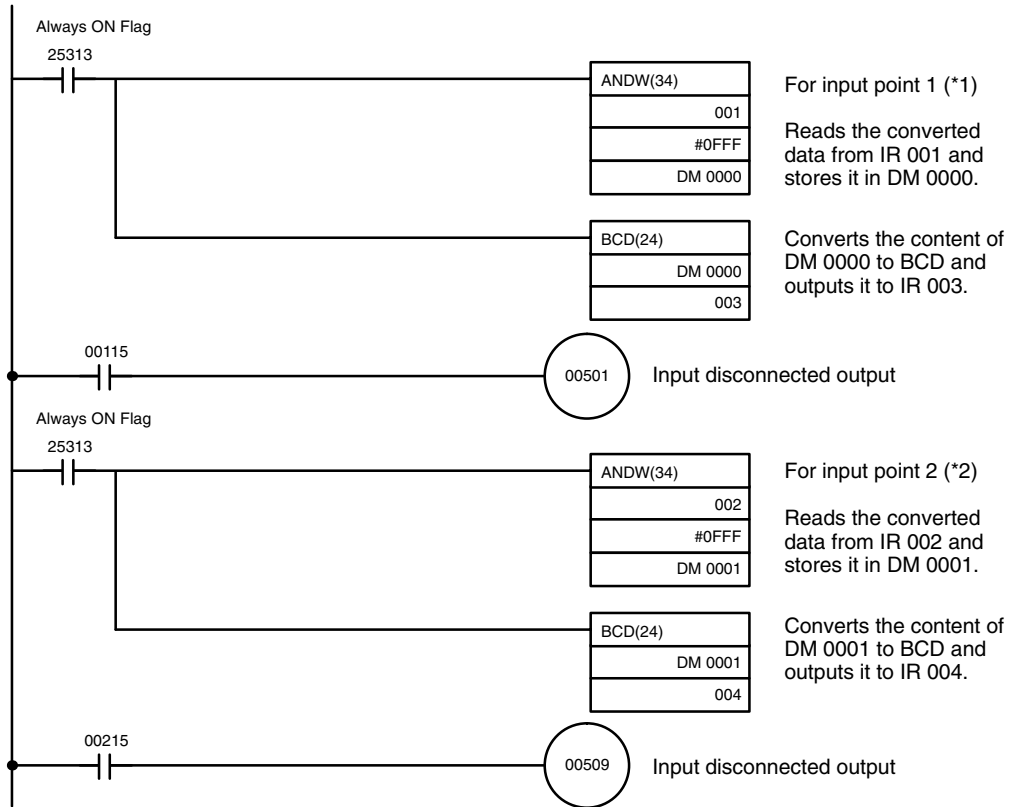

Note The Analog Input Unit outputs 16-bit data but bits 0 to 11 are the converted data and bit 15 is the disconnection detection signal. Therefore, the converted data only is read at *1 and *2 in the program.

SECTION 3

3G2A5-AD006 and 3G2A5-AD007 Analog Input Units

This section provides information on 3G2A5-AD006 and 3G2A5-AD007 Analog Input Units including the specifications, connections, IR/CIO bit allocations, and applications.

3-1	Specifications and General Information	18
3-1-1	Specifications	18
3-1-2	Description of Parts	19
3-1-3	Block Diagram	20
3-1-4	Wiring	21
3-2	IR/CIO Bit Allocations	23
3-3	Functions and User Programs	23
3-3-1	Input Signals and Converted Data	23
3-3-2	Ladder Programming Example	24

3-1 Specifications and General Information

3-1-1 Specifications

General Specifications

All general specifications of the 3G2A5-AD006 and 3G2A5-AD007 Analog Input Units conform to those of the C Series, except the following.

- Insulation between the External Terminals and the Frame:
5M Ω min. at 250 VDC
- Breakdown Voltage between the External Terminals and the Frame:
500 VAC, 50-60 Hz for 1 minute

Performance Specifications

Item	Specification		
Number of analog inputs	4		
Input signal range	Voltage input	AD006	1 to 5 V
		AD007	0 to 10 V
	Current input	AD006	4 to 20 mA
Max. input signal	Voltage input	± 15 V max.	
	Current input	± 60 mA max.	
External input impedance	Voltage input	1 M Ω min.	
	Current input	250 Ω	
Resolution	1/1023 (full scale)		
PC signal	10-bit binary		
Linearity error	$\pm 0.2\%$ max.		
Accuracy	$\pm 0.2\%$ max. (full scale at 25°C)		
Accuracy temperature coefficient	± 150 PPM/ $^{\circ}$ C (full scale)		
Conversion time	2.5 ms max./point		
Conversion cycle	10 ms max.		
Max. PC write delay (see note)	1 s max.		
Conversion method	Sequential comparison		
Words allocated	4 input words		
External connections	17-pin terminal block (not removable)		
Power consumption	750 mA max. at 5 VDC		
External dimensions	34.5 x 250 x 113 mm (W x H x D)		
Weight	650 g max.		

Note The PC write delay is the time required for a change in the input signal to be converted and transferred to the PC bus.

PC Write Delay

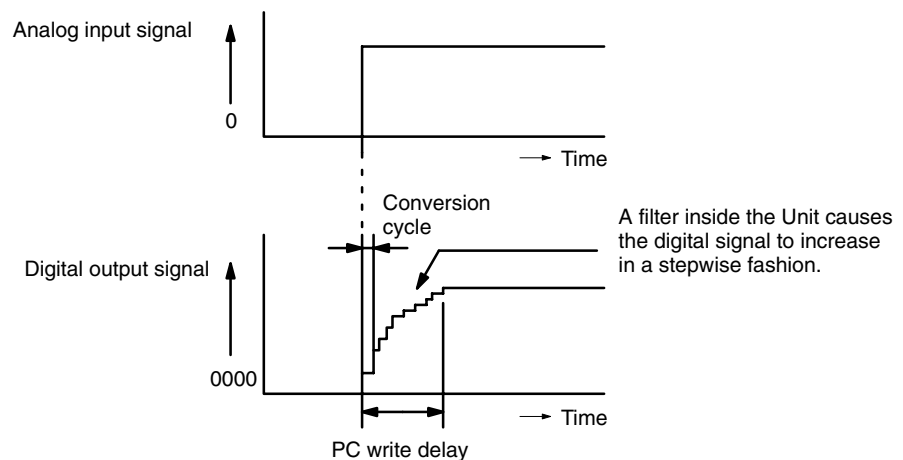

3-1-2 Description of Parts

3G2A5-AD006/007

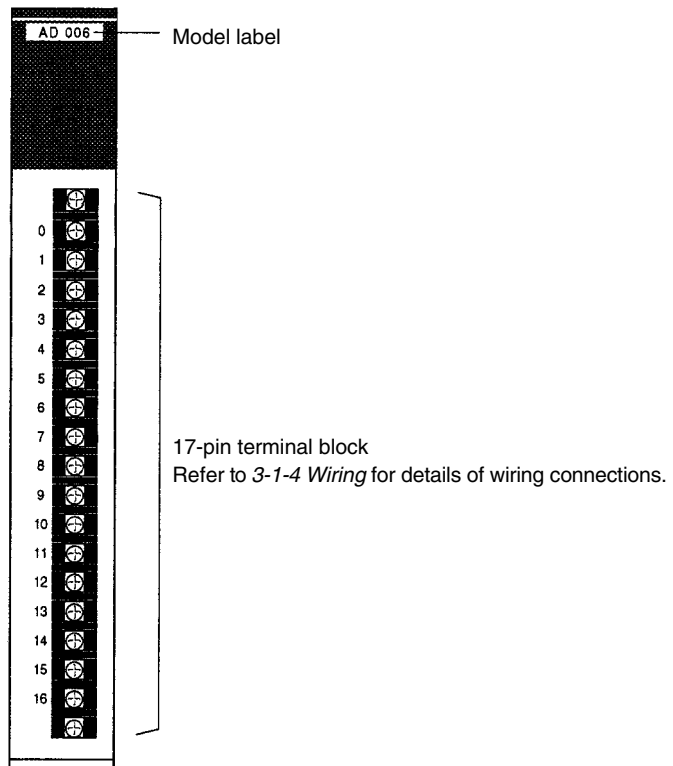

3-1-3 Block Diagram

The following diagram shows the basic internal connections of the Unit.

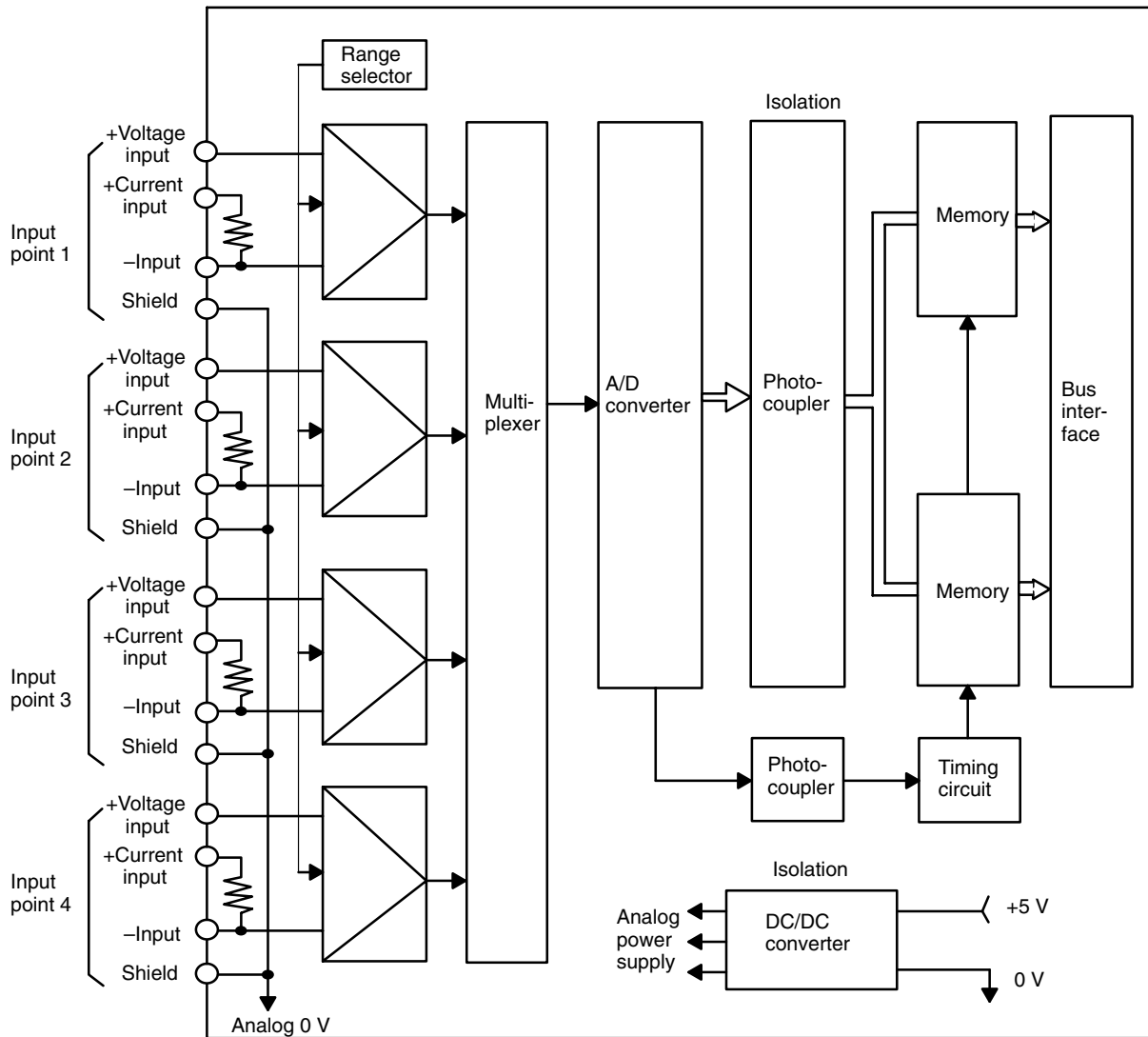

3-1-4 Wiring

Voltage Inputs

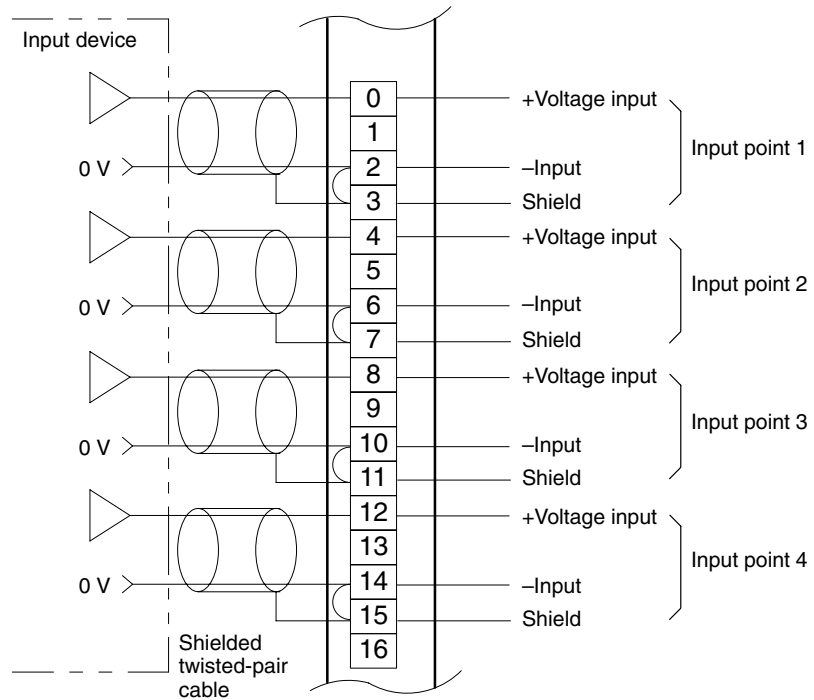

Current Inputs

The following diagram shows the wiring when separate power supplies are used for input points 1 through 4.

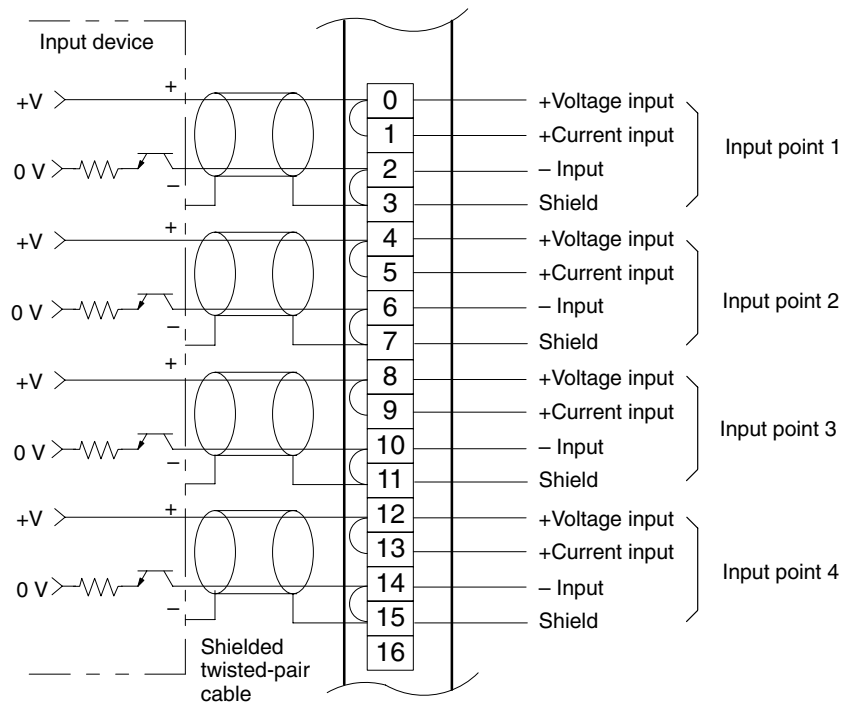

The following diagram shows the wiring when the same power supply is used for input points 1 through 4.

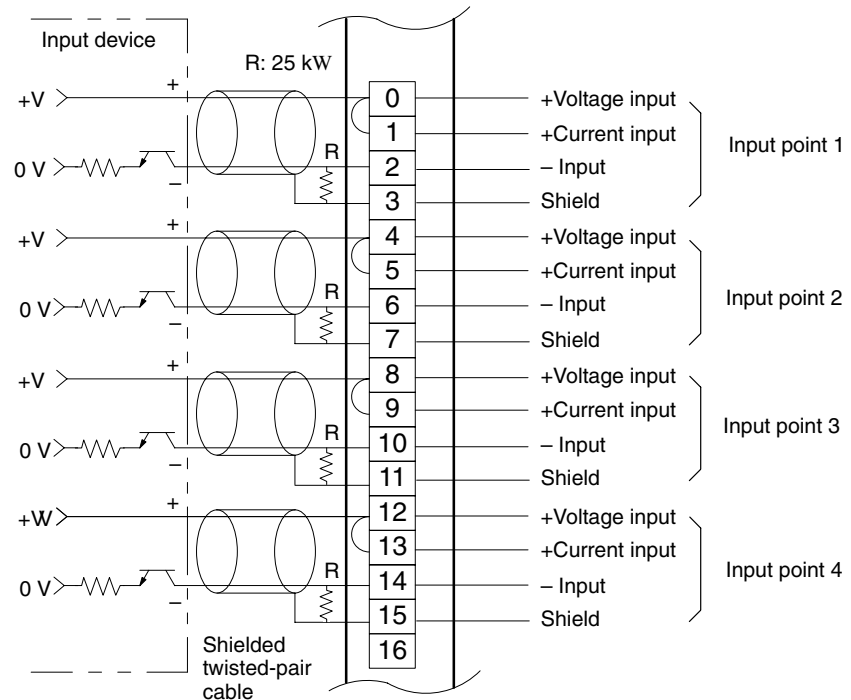

Precautions

- 1, 2, 3... 1. Use shielded twisted-pair cable for external connections.
2. Connect the positive and negative terminals of any unused input points to the shield terminal.
3. For voltage inputs, short the negative and shield terminals.
4. For current inputs, connect the terminals as described below, according to whether input points 1 through 4 are isolated. Inaccurate data will be obtained if the shield terminal is open.
 - a) When Separate Power Supplies Are Used for Input Points 1 through 4 (Input Points Isolated)

Connect the positive terminal to the resistance terminal at each input point.

Connect the negative terminal to the shield terminal at each input point.
 - b) When the Same Power Supply Is Used for Input Points 1 through 4 (Input Points Not Isolated)

Connect the positive terminal to the resistance terminal at each input point.

Connect a 25 k Ω -min. (1/4 W) carbon resistor between the negative terminal and the shield terminal at each input point.

If the same power supply is used for input points 1 through 4 with wiring connections as specified for separate power supplies (see previous diagram), interference between the input points will result because the shield terminals are joined inside the Analog Input Unit.

3-2 IR/CIO Bit Allocations

The IR/CIO bit allocations are shown below. Each Unit is allocated four words.

Bit	Input words			
	IR/CIO n: Point 1	IR/CIO n+1: Point 2	IR/CIO n+2: Point 3	IR/CIO n+3: Point 4
0	A/D converted data 2^0	A/D converted data 2^0	A/D converted data 2^0	A/D converted data 2^0
1	A/D converted data 2^1	A/D converted data 2^1	A/D converted data 2^1	A/D converted data 2^1
2	A/D converted data 2^2	A/D converted data 2^2	A/D converted data 2^2	A/D converted data 2^2
3	A/D converted data 2^3	A/D converted data 2^3	A/D converted data 2^3	A/D converted data 2^3
4	A/D converted data 2^4	A/D converted data 2^4	A/D converted data 2^4	A/D converted data 2^4
5	A/D converted data 2^5	A/D converted data 2^5	A/D converted data 2^5	A/D converted data 2^5
6	A/D converted data 2^6	A/D converted data 2^6	A/D converted data 2^6	A/D converted data 2^6
7	A/D converted data 2^7	A/D converted data 2^7	A/D converted data 2^7	A/D converted data 2^7
8	A/D converted data 2^8	A/D converted data 2^8	A/D converted data 2^8	A/D converted data 2^8
9	A/D converted data 2^9	A/D converted data 2^9	A/D converted data 2^9	A/D converted data 2^9
10	0	0	0	0
11	0	0	0	0
12	0	0	0	0
13	0	0	0	0
14	0	0	0	0
15	0	0	0	0

3-3 Functions and User Programs

3-3-1 Input Signals and Converted Data

The Analog Input Unit converts analog input signals into digital data. The analog input signals must be unipolar inputs. Three models are available to support different analog input ranges.

Unipolar Input

Input Ranges: 1 to 5 V 3G2A5-AD006
 4 to 20 mA 3G2A5-AD006
 0 to 10 V 3G2A5-AD007

Converted Output: A/D converted data, 10-bit binary data

Relationship Between Input Signals and A/D Conversion Data

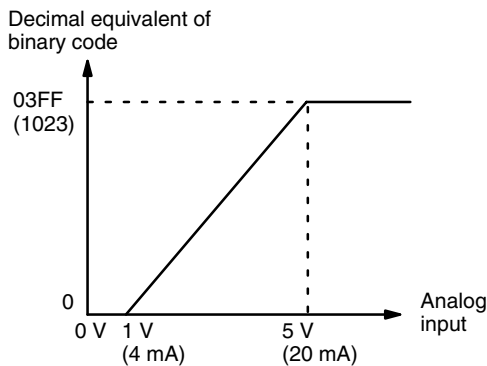

Input: 1 to 5 V, 4 to 20 mA

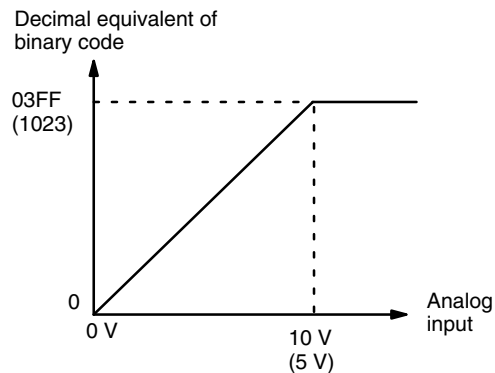

Input: 0 to 10 V

3-3-2 Ladder Programming Example

The following example program converts four different analog input signals to 4-digit BCD values (1023 maximum) and outputs the result.

Connections

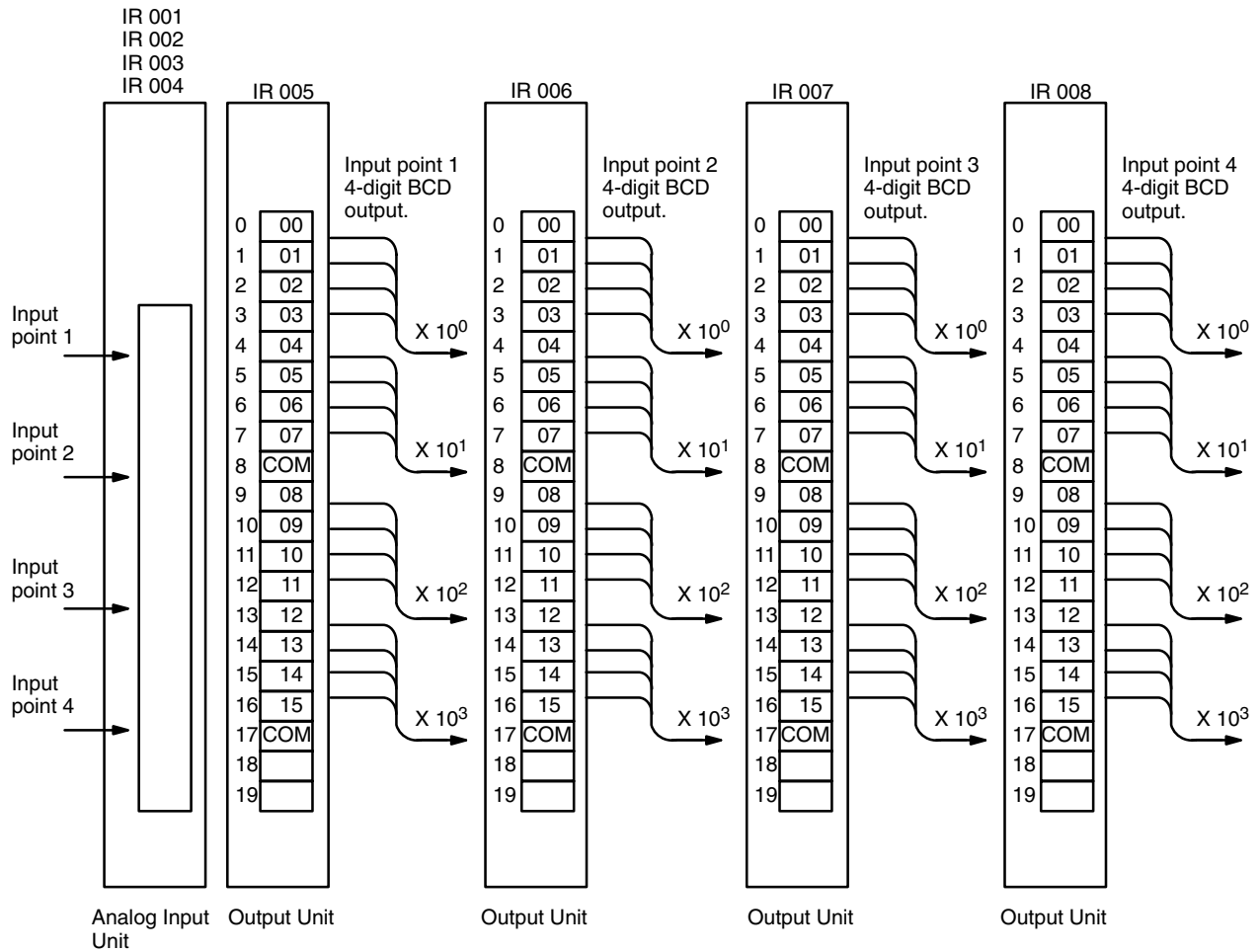

Program Example Using C1000H

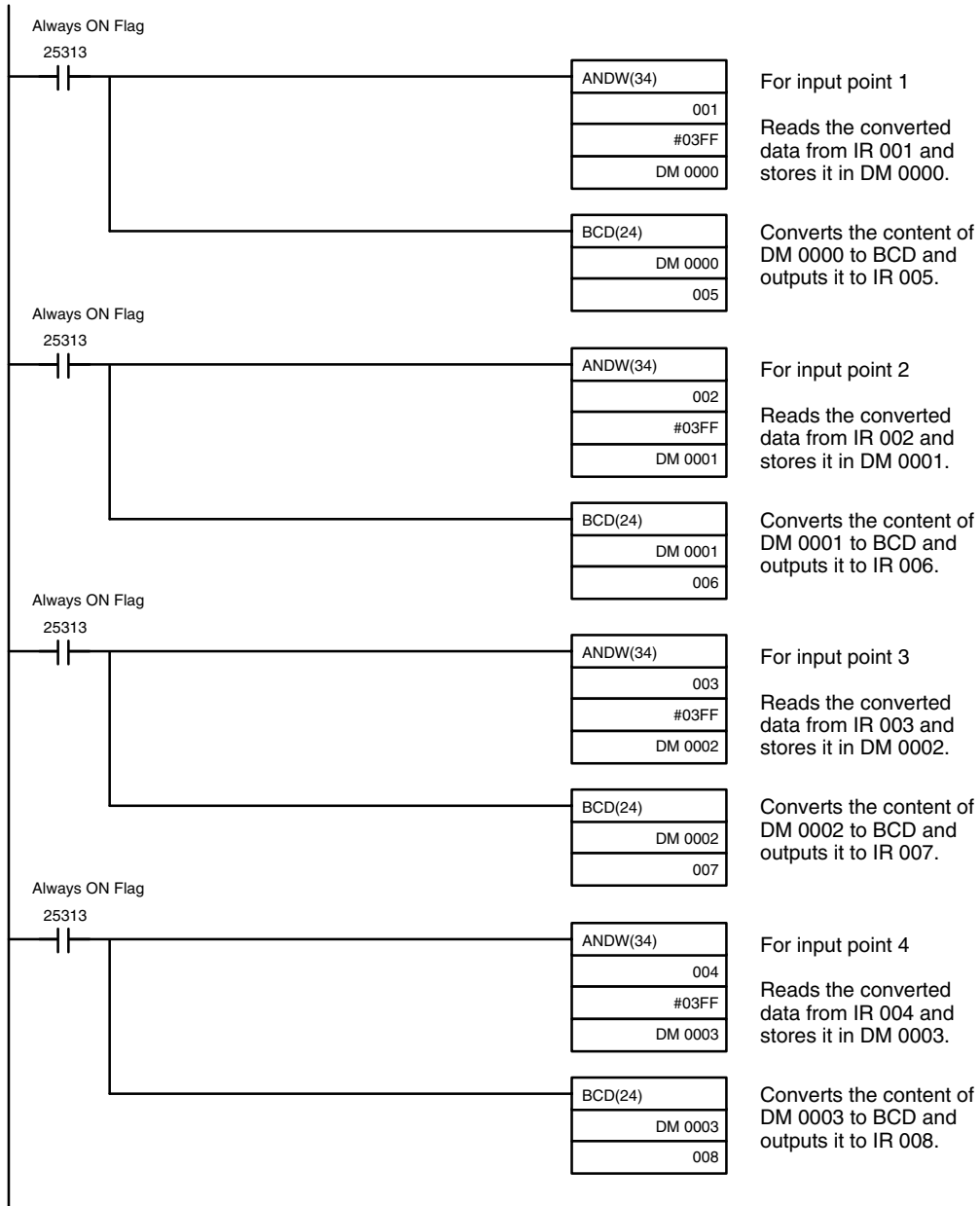

SECTION 4

C500-AD101 Analog Input Unit

This section provides information on the C500-AD101 Analog Input Unit including the specifications, connections, IR/CIO bit allocations, and applications for both two-word and four-word operation.

4-1	Specifications and General Information	28
4-1-1	Specifications	28
4-1-2	Description of Parts	29
4-1-3	Block Diagram	30
4-2	Functions, Settings and Wiring	31
4-2-1	Operational Flow	31
4-2-2	Functions	32
4-2-3	Word Operating Mode	33
4-2-4	Setting the Input Ranges	34
4-2-5	Wiring	36
4-3	Two-word Operation	37
4-3-1	Communications with CPU Unit	37
4-3-2	IR/CIO Bit Allocations	39
4-3-3	DM Allocations	40
4-3-4	Programming Examples	43
4-4	Four-word Operation	50
4-4-1	Communications with CPU Unit	50
4-4-2	IR/CIO Bit Allocations	50
4-4-3	Programming Examples	51

4-1 Specifications and General Information

4-1-1 Specifications

General Specifications

All general specifications of the C500-AD101 Analog Input Unit conform to those of the C Series.

Performance Specifications

Item	Specification	
Number of analog inputs	8	
Input signal range (see note 1)	Voltage input	Settable in the range 0 to 10 V
	Current input	Settable in the range 0 to 20 mA
Max. input signal	Voltage input	±15 V
	Current input	±30 mA
External input impedance	Voltage input	1 MΩ min.
	Current input	250 Ω
Resolution (see note 2)	1/4095 (full scale)	
CPU Unit signal	12-bit binary	
Overall accuracy	25°C	±0.5 % max. (full scale, including linearity error)
	0 to 55°C	±1.0 % max. (full scale, including linearity error)
Conversion time (see note 3)	10 ms max./point	
Words allocated	2 or 4 input words (settable by switch)	
External connections	30-pin terminal block (not removable)	
Isolation	Between input terminals and CPU Unit: Photo-coupler	
	Between input terminals and Unit: None	
Power consumption	880 mA max. at 5 VDC	
External dimensions	34.5 x 250 x 120 mm (W x H x D)	
Weight	700 g max.	

- Note**
1. Set the required input signal range between 0 V and 10 V, 0 mA and 20 mA.
 2. The resolution is 1/4095 for a difference between gain and offset levels of 4 V (16 mA) min. The resolution decreases as this difference decreases. The resolution is 1/2047 for a difference of 2 V.
 3. The conversion time is defined as the time to convert the full range (e.g., 1 to 5 V) of input data written to the Analog Input Unit.

4-1-2 Description of Parts

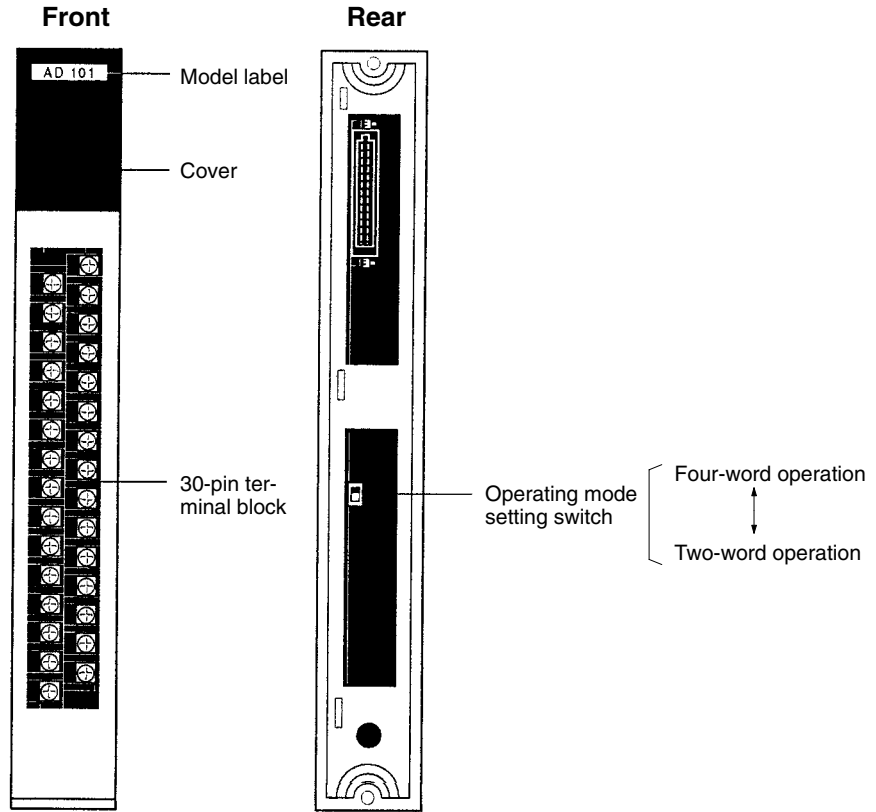

Under the Cover

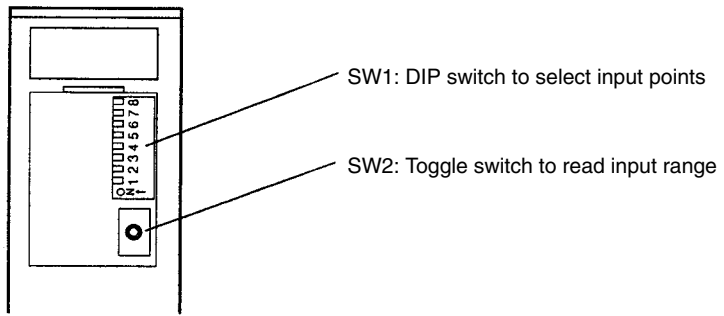

4-1-3 Block Diagram

The following diagram shows the basic internal connections of the Unit.

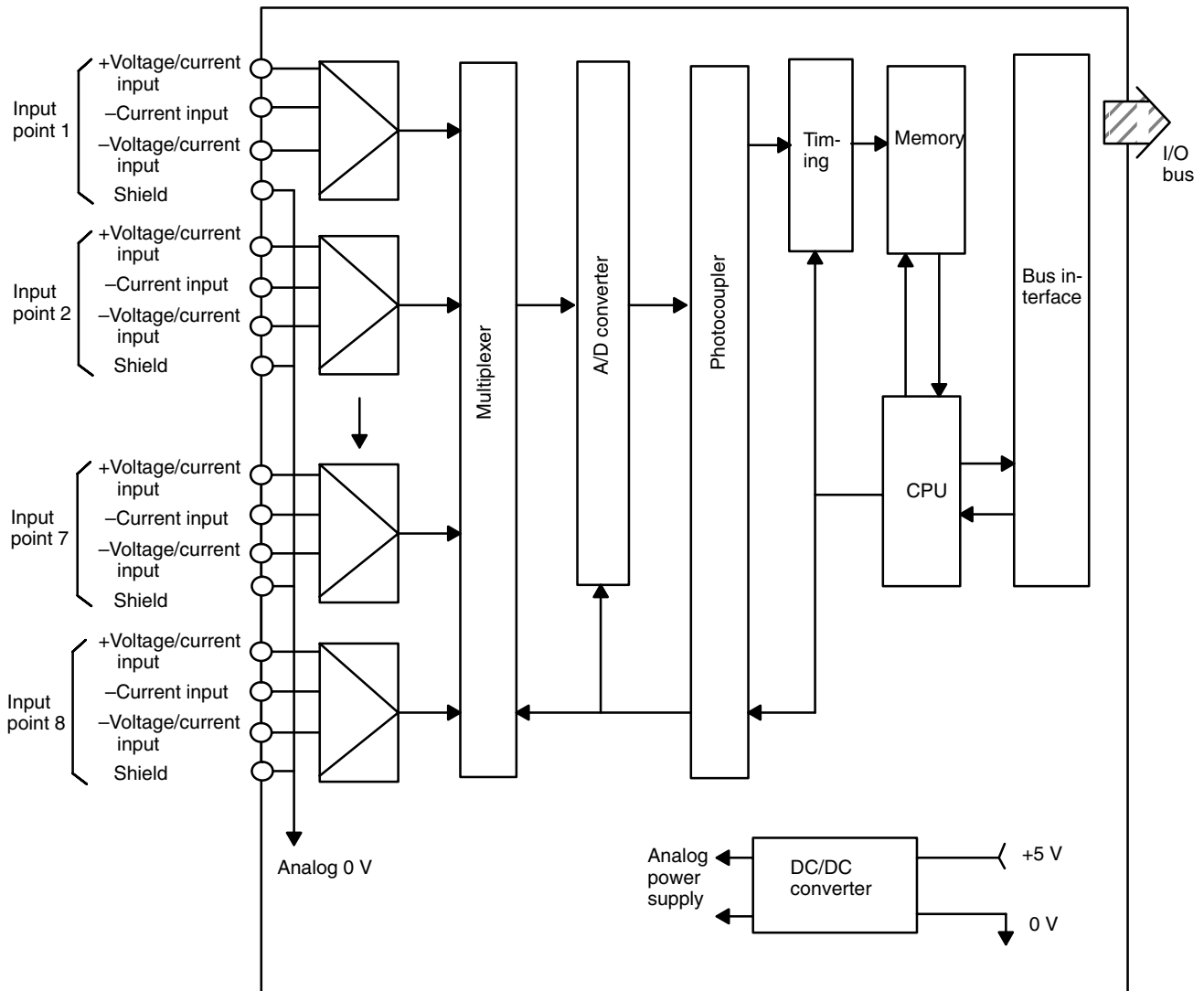

4-2 Functions, Settings and Wiring

4-2-1 Operational Flow

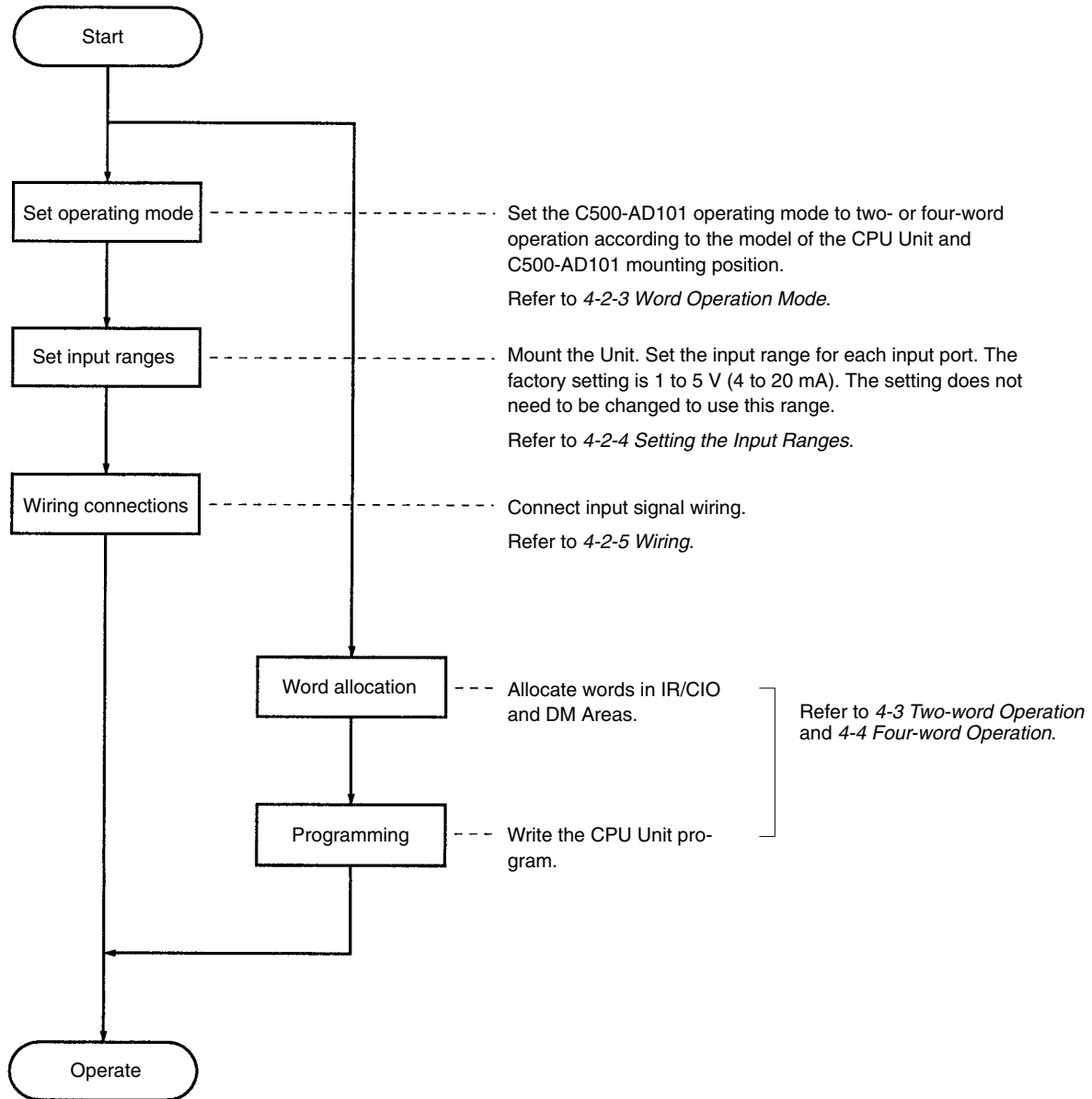

4-2-2 Functions

A/D Conversion

The relationships between the input analog values and the converted binary values are shown below. Binary values are given with their hexadecimal equivalents.

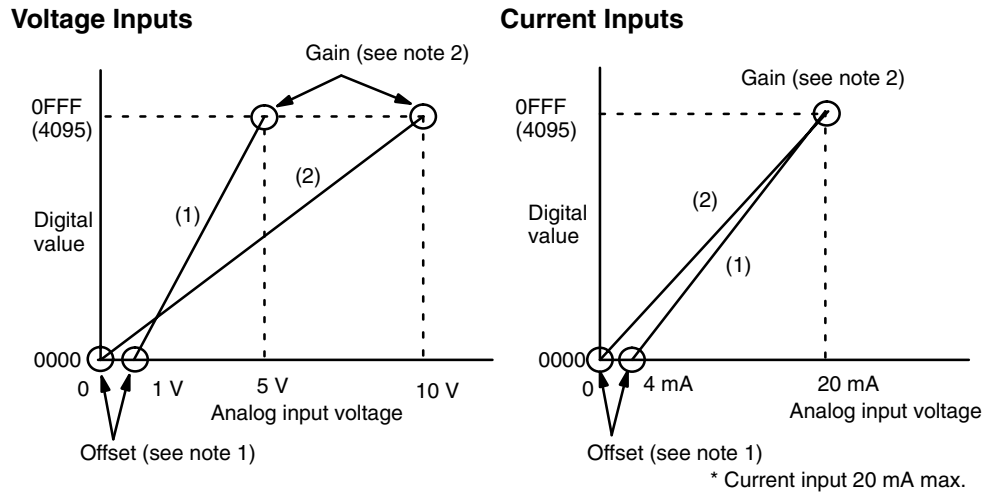

Analog input voltage and current values are converted to binary between the offset and gain values set for the input.

Line (1) in the above figures shows the factory settings of 1 to 5 V (4 to 20 mA). This means that an input of 1 V (4 mA) will be converted to 000_{Hex} and an input of 5 V (20 mA) will be converted to FFF_{Hex}.

The maximum ranges, 0 to 10 V (0 to 20 mA) are shown by line (2) in the figures.

- Note**
1. For voltage input, if the offset or gain is set outside the range of 0 to 10 V, the output is locked at 000_{Hex} or FFF_{Hex}, respectively. For current input, the output corresponding to a negative current input is locked at 000_{Hex} but the output corresponding to an input exceeding 20 mA is not locked.
 2. The offset is the analog input value corresponding to an output of 000_{Hex}.
 3. The gain is the analog input value corresponding to an output of FFF_{Hex}.

C500-AD101 Functions

The C500-AD101 offers the following four functions in addition to A/D conversion.

Mean Value

The mean input data value over the specified sampling count is output. Specify the sampling count between 2 and 9,999. The maximum conversion time is 10 ms per input.

Peak Hold

The peak value of the input signals is held and output when requested by the CPU Unit. The peak value can be reset by an instruction from the CPU Unit.

Disconnection Detection

Detects if an input lead is disconnected, and turns the Disconnection Detect Flag ON. The disconnection detection level is half or less of the lower limit specified by the user. If, for example, 4 mA is specified as the lower limit, disconnection will be detected when the current value drops below 2 mA. This function is not available if the gain is lower than 1 V (4 mA).

Scaling

The C500-AD101 normally outputs hexadecimal values in the range 000_{Hex} to FFF_{Hex}. However, scaling can be used to convert the outputs into 4-digit BCD data.

The offset and gain are set individually to convert the outputs to the BCD data required.

Scaling is not available during four-word operation.

Note The conversion time is 10 ms for A/D conversion only, but 1 or 2 ms more is required for internal processing if many of the functions above are used.

4-2-3 Word Operating Mode

C500-AD101 can be set to be allocated two or four words to match the model of the CPU Unit and the Rack to which the Unit is mounted.

Operating mode	PC	Instructions	Rack
Two-word	CVM1, CV, C2000H, C1000H, C500	I/O READ and I/O WRITE Instructions: READ and WRIT	CPU Rack, I/O Rack, Expansion I/O Rack, SYSMAC BUS/2 Slave Rack
Four-word		MOVE instruction: MOV	CPU Rack, I/O Rack, Expansion I/O Rack, SYSMAC BUS Slave Rack

Note Two-word operation can be set only when the CPU Unit and the Rack to which the Unit is mounted support the I/O READ and I/O WRITE instructions, READ and WRIT.

When using the C500, only the 3G2C3-CPU11-EV1 CPU Unit supports READ and WRIT.

Even when using a CPU Unit which does support READ and WRIT, set the C500-AD101 to four-word operation if it is mounted to a SYSMAC BUS Slave Rack.

Two-word Operation

Data transfer between C500-AD101 and CPU Unit using the read (READ) and write (WRIT) instructions. Programming is simple and the immediate execution (I/O refresh immediately after instruction execution) achieves high-speed processing.

Four-word Operation

Data transfer between C500-AD101 and CPU Unit using the MOV instruction. Using the MOV instruction, I/O refresh is matched to the CPU Unit cycle time.

Always set the C500-AD101 to four-word operation when using it with a CPU Unit that does not support the I/O READ and I/O WRITE instructions (READ and WRIT) or when it is mounted to a SYSMAC BUS Slave Rack.

Setting the Switch

Set this switch before mounting the C500-AD101. This switch setting is read when the PC's power supply is turned ON.

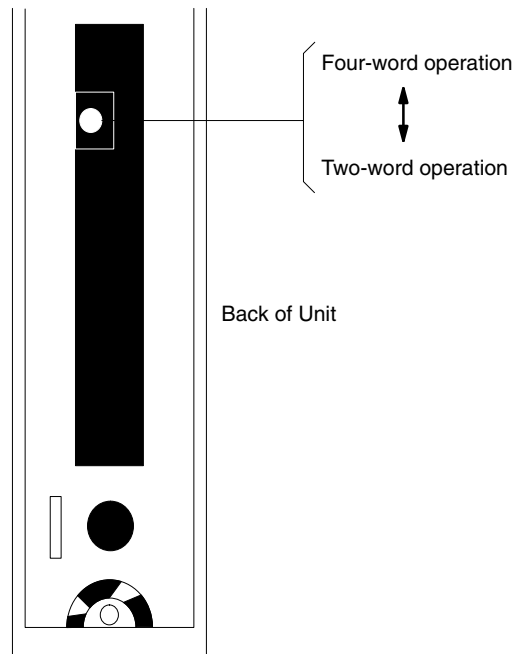

4-2-4 Setting the Input Ranges

The procedure for setting the type and range of the input signals at each input point is described below. Each point is set to an offset (minimum) of 1 V (4 mA) and a gain (maximum) of 5 V (20 mA). Use the following procedure to change these settings if necessary.

Preparations

- 1, 2, 3... 1. A DC power supply and measuring instruments are required for this setting, as follows:
 Voltage Input: 0 to 10 VDC power supply and DC voltmeter
 Current Input: 0 to 20 mA power supply and DC ammeter
2. Mount the C500-AD101 and connect the DC power supply and meter. Each input point can be independently set for voltage input or current input.

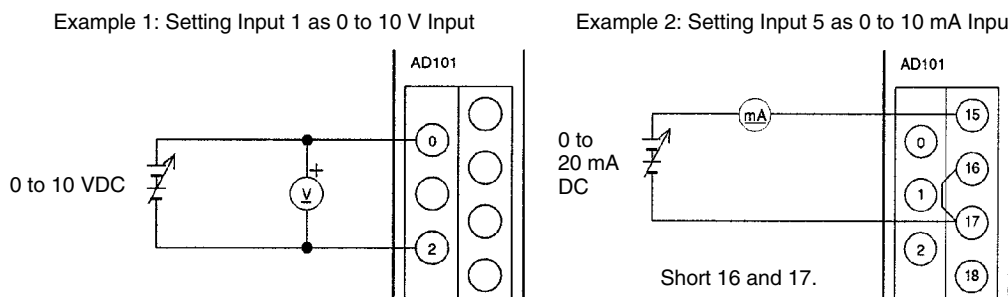

3. Turn ON the PC.
 The PC power supply must be ON when the input ranges are set.

- Follow the setting procedure described below to set the input range for each input point.

Removing the Cover

Place your thumb at the bottom left edge of the cover and push it to the right.

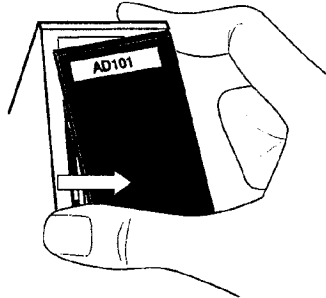

Under the Cover

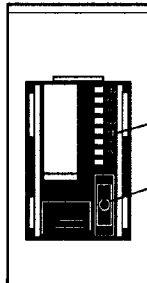

SW1 (DIP switch to select input points)
SW2 (toggle switch to read input range)

Attaching the Cover

Hold the cover between your thumb and middle finger, position the lower edge and push the cover into place with your index finger.

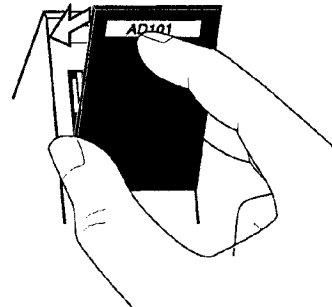

Setting Procedure

1, 2, 3...

- Remove the cover from the front face of the Unit.
- The numbers on the DIP switch pins (SW1) indicate the input ports 1 to 8. Initially, turn ON only pin 1 and make sure that all other pins are OFF.

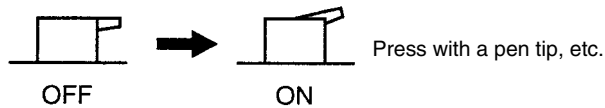

- Apply the minimum (offset) value of voltage (0 V) or current (0 mV) to input 1. The offset converted output is 000_{Hex}.
- Set the toggle switch (SW2) down to read the offset.

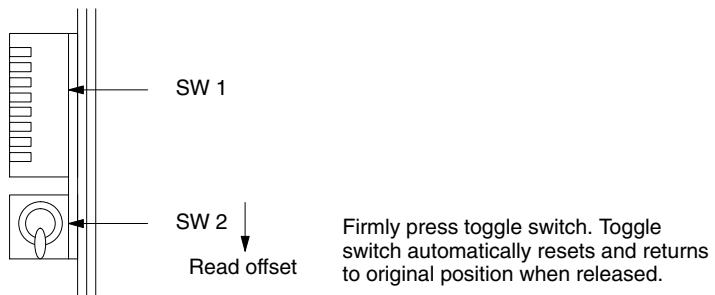

- Apply the maximum (gain) value of voltage (10 V) or current (10 mV) to input 1. The gain converted output is FFF_{Hex}.
- Set the toggle switch (SW2) up to read the gain.

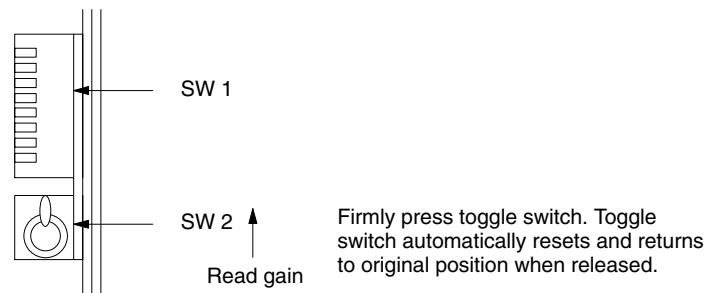

7. Repeat the previous steps to set the offset and gain for input points 2 through 8.
8. Replace the cover at the front of the Unit when the settings are complete.

! Caution Turn ON only one DIP switch pin. Do not turn ON two pins at the same time.

4-2-5 Wiring

Terminal Connections

Point 1	+ Voltage/current input 1	0	15	+ Voltage/current input 5	Point 5
	- Current input 1	1	16	- Current input 5	
	- Voltage/current input 1	2	17	- Voltage/current input 5	
Shield		3	18	Shield	
Point 2	+ Voltage/current input 2	4	19	+ Voltage/current input 6	Point 6
	- Current input 2	5	20	- Current input 6	
	- Voltage/current input 2	6	21	- Voltage/current input 6	
Not connected		7	22	Not connected	
Point 3	+ Voltage/current input 3	8	23	+ Voltage/current input 7	Point 7
	- Current input 3	9	24	- Current input 7	
	- Voltage/current input 3	10	25	- Voltage/current input 7	
Shield		11	26	Shield	
Point 4	+ Voltage/current input 4	12	27	+ Voltage/current input 8	Point 8
	- Current input 4	13	28	- Current input 8	
	- Voltage/current input 4	14	29	- Voltage/current input 8	

- Note**
1. When using current input, short the negative voltage/current input terminal to the negative current input terminal.
 2. Connect all shield terminals to the analog 0 V.

Input Connections

The input wiring connections to the C500-AD101 differ for voltage input and current input.

Voltage Input

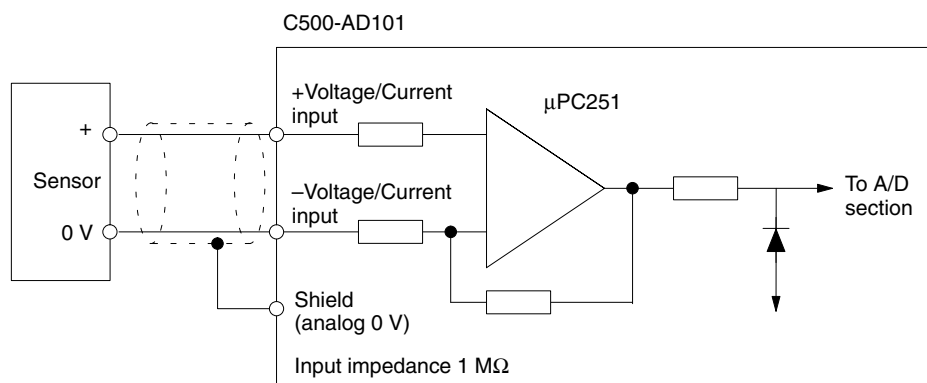

Current Input

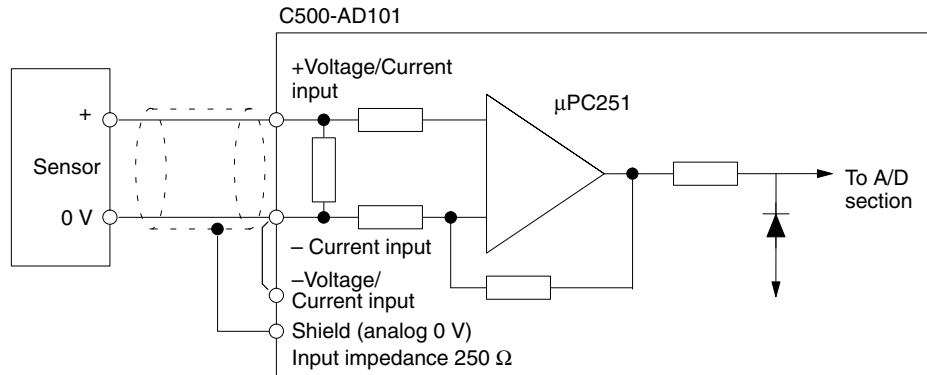

- Note**
1. When using current input, short the negative voltage/current input terminal to the negative current input terminal.
 2. Use shielded twisted-pair cable for external connections.

4-3 Two-word Operation

4-3-1 Communications with CPU Unit

The I/O READ and I/O WRITE instructions, READ and WRIT, are used for data transfer between the C500-AD101 and the CPU Unit in two-word operation mode.

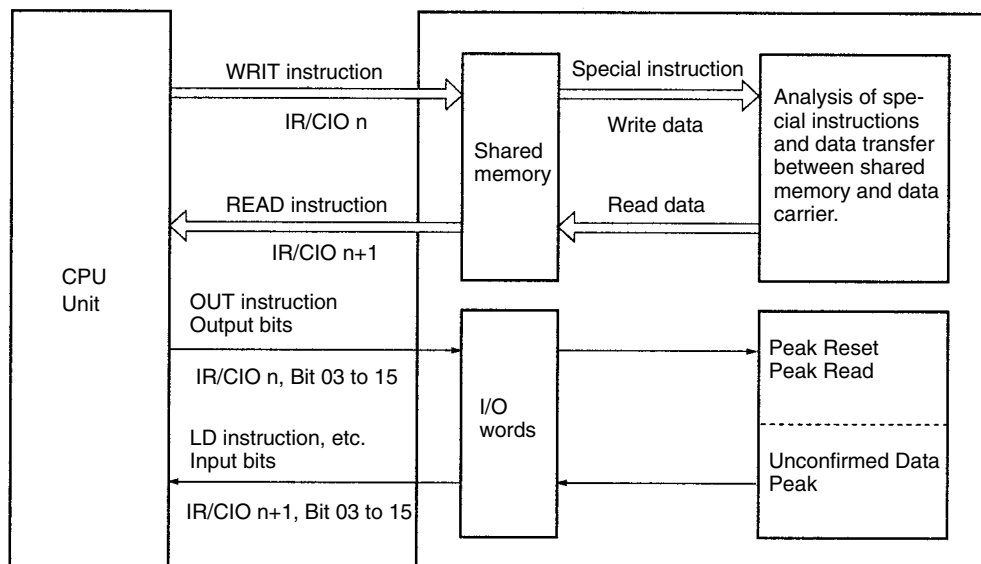

The I/O WRITE Instruction, WRIT, is executed when the instruction execution conditions are ON and the A/D Busy Flag (IR/CIO n+1, Bit 00) and A/D Read Completed Flag (IR/CIO n+1, Bit 01) are both OFF.

A NOP (No Operation) results if either the A/D Busy Flag or A/D Read Completed Flag is ON.

When execution of the instruction is complete, the PC Write Completed Flag (IR/CIO n, Bit 01) turns ON temporarily (differential output) and the Equal Flag (SR 6306, SR 25506, A50006) turn ON. Completion of WRIT instruction execution can be evaluated from the Equal Flag immediately after the WRIT instruction.

The I/O READ instruction, READ, is executed when the instruction execution conditions are ON, the A/D Busy Flag (IR/CIO n+1, Bit 00) is OFF, and A/D Write Completed Flag (IR/CIO n+1, Bit 01) is ON.

A NOP (No Operation) results if the A/D Busy Flag is ON or the A/D Write Completed Flag is OFF.

Immediate execution is used for the READ and WRIT instructions, but I/O data is handled by the MOV instruction, which is executed according to I/O refresh timing. During programming, take into account the difference in timing between writing the data to shared memory and data output.

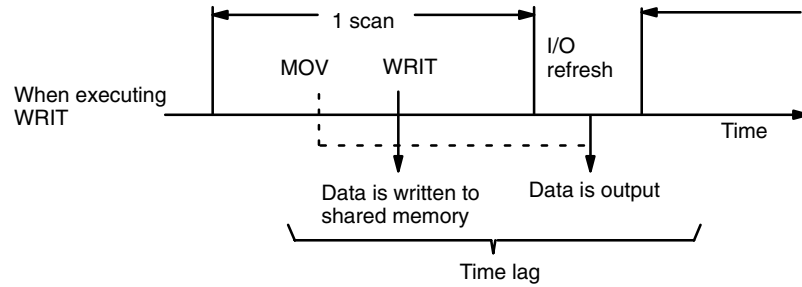

I/O WRITE Instruction – WRIT

WRIT	
W	← Number of words transferred
S	← Transfer start address
D	← Specify word n allocated to the Unit.

I/O READ Instruction – READ

READ	
W	← Number of words transferred
S	← Specify word n + 1 allocated to the Unit.
D	← Destination address

The function codes for the I/O READ and I/O WRITE instructions, READ and WRIT, differ according to the PC, as shown in the table below.

Instruction	Mnemonic	Function code	
		C500/C1000H/C2000H	CVM1/CV
I/O WRITE instruction	WRIT	87	191
I/O READ instruction	READ	88	190

READ/WRIT Execution Restrictions

- 1, 2, 3... 1. The differentiated READ and WRIT instructions cannot be executed for Special I/O Units on SYSMAC BUS/2 Slave Racks. The READ and WRIT instructions must be executed until the = Flag (A50006) turns ON indicating that the execution is completed.
2. The READ and WRIT instructions cannot be simultaneously executed for the same Special I/O Unit. In such cases, execute WRIT first, and after the execution is completed, execute READ.
3. One SYSMAC BUS/2 Remote I/O Master Unit can simultaneously handle up to two READ and WRIT instructions. If two READ and WRIT instructions are executed for Units mounted to SYSMAC BUS/2 Slave Racks and an attempt is made to execute a READ or WRIT instruction for a third Unit, the CY Flag (A50004) will be turned ON without executing the third instruction.
4. Therefore, when continuously executing READ instructions, you can use the READ and WRIT instructions for a maximum of two Special I/O Units under each SYSMAC BUS/2 Remote I/O Master Unit.

5. Up to four SYSMAC BUS/2 Remote I/O Master Units can be mounted to the CV1000 or CV2000. In this case, therefore, up to eight READ and WRIT instructions can be executed simultaneously.
6. Up to 255 words can be transferred using a READ or WRIT instruction.

4-3-2 IR/CIO Bit Allocations

Allocations

Bit	Words	
	Output	Input
	IR/CIO n	IR/CIO n+1
00	PC Busy	A/D Busy
01	PC Write Complete	A/D Write Complete
02	PC Read Complete	A/D Read Complete
03	0	Unconfirmed Data Flag
04	0	0
05	0	0
06	0	0
07	Peak Reset Bit	0
08	Peak Read Bit 1	Peak Flag 1
09	Peak Read Bit 2	Peak Flag 2
10	Peak Read Bit 3	Peak Flag 3
11	Peak Read Bit 4	Peak Flag 4
12	Peak Read Bit 5	Peak Flag 5
13	Peak Read Bit 6	Peak Flag 6
14	Peak Read Bit 7	Peak Flag 7
15	Peak Read Bit 8	Peak Flag 8

Unconfirmed Data Flag

This flag turns ON when the converted data is unconfirmed, when power is turned ON, for example.

Peak Reset Bit

This bit is turned ON with one or more of the Peak Read Bits in order to reset the peak values of the input points designated by the Peak Read Bit.

Peak Read Bits

Use a Peak Read Bit with the Peak Bit to read the peak value for a particular input point. Turn this bit ON with the Peak Reset Bit to reset the stored peak value.

Peak Flags

A Peak Flag turns ON to indicate that the input value of the input point has reached a peak value.
Use this flag with the Peak Read Flag to read the peak value for a particular input point.



Caution

The user cannot use IR/CIO n and IR/CIO n+1, Bits 0 to 2.

Words n and n+1 indicate the IR/CIO addresses according to the slot in which the Analog Input Unit is mounted. When using the I/O READ and I/O WRITE instructions (READ and WRIT), n and n+1 are the write (output) and read (input) addresses, respectively.

4-3-3 DM Allocations

Data Writing Area

The I/O WRITE Instruction (WRIT) is used to transfer a maximum of 26 words of data to the Analog Input Unit.

The following applies if mean value and scaling are not used together.

All Input Points Used: No setting of WRIT data required. Use without changing the settings.

Some Input Points Unused: Transfer the data set in DM 0000 and DM 0001 to the Analog Input Unit with the WRIT instruction.

Point	DM word	Bit															
		15	14	13	12	11	10	9	8	7	6	5	4	3	2	1	0
0	DM m	Specify points for mean function								Specify points to be used							
1	DM m+1	Specify points for scaling function								0				0			
2	DM m+2	Mean value 1															
3	DM m+3	Mean value 2															
4	DM m+4	Mean value 3															
5	DM m+5	Mean value 4															
6	DM m+6	Mean value 5															
7	DM m+7	Mean value 6															
8	DM m+8	Mean value 7															
9	DM m+9	Mean value 8															
10	DM m+10	Scaling offset 1															
11	DM m+11	Scaling gain 1															
12	DM m+12	Scaling offset 2															
13	DM m+13	Scaling gain 2															
14	DM m+14	Scaling offset 3															
15	DM m+15	Scaling gain 3															
16	DM m+16	Scaling offset 4															
17	DM m+17	Scaling gain 4															
18	DM m+18	Scaling offset 5															
19	DM m+19	Scaling gain 5															
20	DM m+20	Scaling offset 6															
21	DM m+21	Scaling gain 6															
22	DM m+22	Scaling offset 7															
23	DM m+23	Scaling gain 7															
24	DM m+24	Scaling offset 8															
25	DM m+25	Scaling gain 8															



Caution

Input the mean value and scaling values only for points for which the mean and/or scaling function has been designated. If one of these is not needed for a point, move all other parameters up one word to replace it. For example, if a mean value is not required for input point 3 but is required for points 1, 2, and 4, the mean value for point 4 would be placed in DM m+ 4 instead of DM m+5.

Data Reading Area

The I/O READ instruction (READ) is used to transfer a maximum of 9 words of data from the Analog Input Unit.

Point	DM word	Bit															
		15	14	13	12	11	10	9	8	7	6	5	4	3	2	1	0
0	DM I	Input point 1 converted data															
1	DM I+1	Input point 2 converted data															
2	DM I+2	Input point 3 converted data															
3	DM I+3	Input point 4 converted data															
4	DM I+4	Input point 5 converted data															
5	DM I+5	Input point 6 converted data															
6	DM I+6	Input point 7 converted data															
7	DM I+7	Input point 8 converted data															
8	DM I+8	0				0				Disconnected Detect Flags							

! Caution Do not allocate the same words for both writing and reading data.

Data Writing Area Setting Contents

Point Specification

If a point is to be used, turn ON the corresponding bit. If a point is not to be used, turn OFF the corresponding bit.

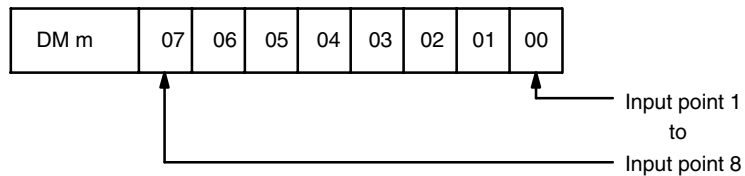

Mean Value Specification

If mean for an input point is to be used, turn ON the corresponding bit. If mean is not to be used, turn OFF the corresponding bit.

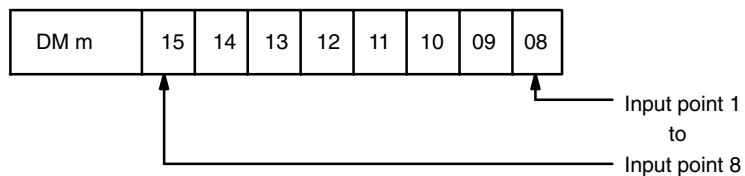

Mean Value Data

This specifies the number of samplings to obtain the mean value as BCD data in the range 2 through 9,999.

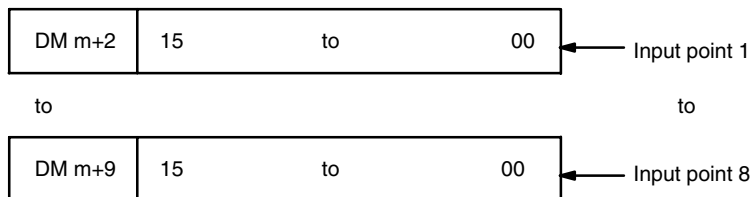

! Caution Set mean value data for the required input points only. If data is not needed for a point, move all parameters up one word to replace it.

Scaling

If scaling is to be used for an input point, turn ON the corresponding bit. If scaling is not to be used, turn OFF the corresponding bit.

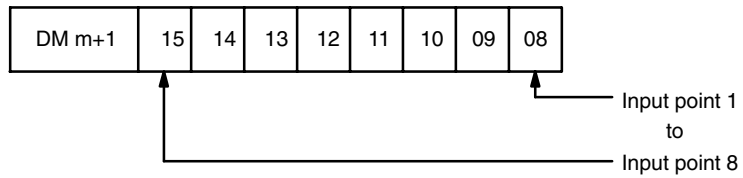

Scaling Data

Enter the offset and gain for each point for which the scaling function has been designated. The offset is the value that is to correspond to 000_{Hex}. The gain is the value corresponding to FFF_{Hex}. The offset and gain must be set in BCD and must be in the range 0 through 9,999.

DM m+10	15	to	00	Offset } Gain }	Input point 1
DM m+11	15	to	00		
to					
DM m+24	15	to	00	Offset } Gain }	Input point 8
DM m+25	15	to	00		

! Caution Set scaling data for the required input points only. If data is not needed at a point, move all parameters up one word to replace it. The gain must be greater than the offset.

Data Reading Area Setting Contents

Input Point Converted Data

A/D converted data is output to the specified words. When scaling is used, data is in 4-bit BCD (bits 00 to 15). When scaling is not used, data is in 3-bit hexadecimal (bits 00 to 11).

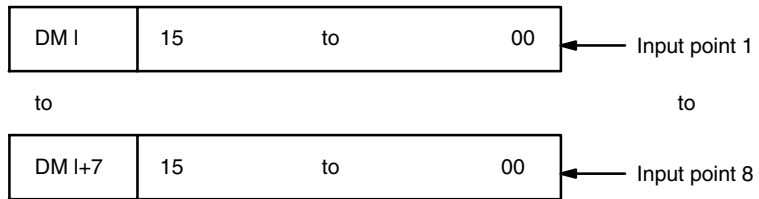

Disconnection Detect Flags

When an input line disconnection is detected, the flag assigned to the input point will turn ON. The offset value must be at least 1 V (4 mA) for these flags to work.

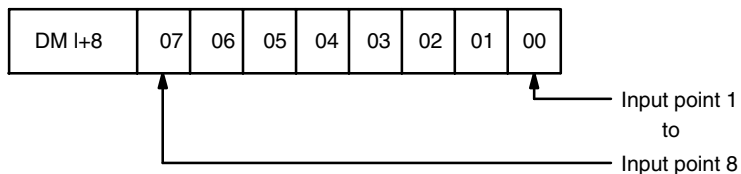

4-3-4 Programming Examples

Example programs are shown below for data transfer between the C500-AD101 Analog Input Unit and the C1000H.

Refer to page 48 for information on using these programs with the CVM1 and CV Series.

Settings Used in the Programming Examples

Input Points

All input points from 1 to 8 are used.

Mean Values

The mean is to be obtained for input points 5 to 8.

Scaling

Scaling used on input points 7 and 8.

Analog Input Unit Mounting Position

The C500-AD101 Analog Input Unit is mounted at IR 000, such that IR 000 is allocated as the output word and IR 001 is allocated as the input word.

DM Area Allocation

Data Writing Area: DM 0000 to DM 0009

Data Reading Area: DM 0100 to DM 0108

Peak Storage Area:

DM 0200 to DM 0207 store peak values of input ports 1 to 8

BCD Converted Data Storage Area:

DM 0300 to DM 0307 store BCD converted data of input ports 1 to 8

Data Writing Area Settings

Address	Set value				Contents
DM 0000	F	0	F	F	Mean value specification/point to be used
DM 0001	C	0	0	0	Scaling specification
DM 0002	0	0	0	5	Point 5
DM 0003	0	0	1	0	Point 6
DM 0004	0	0	2	0	Point 7
DM 0005	0	0	5	0	Point 8
DM 0006	0	0	0	0	Point 7 Offset data
DM 0007	3	0	0	0	Point 7 Gain data
DM 0008	1	0	0	0	Point 8 Offset data
DM 0009	5	0	0	0	Point 8 Gain data

Contents of DM 0000

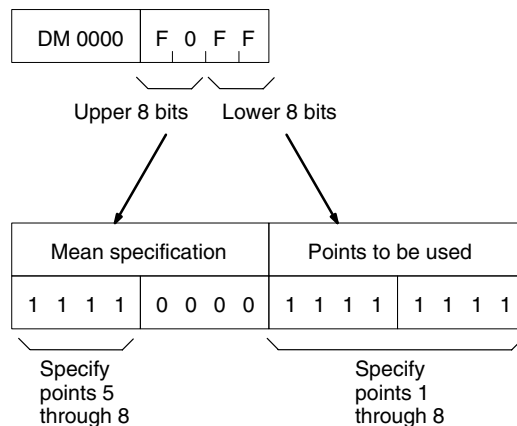

Contents of DM 0001

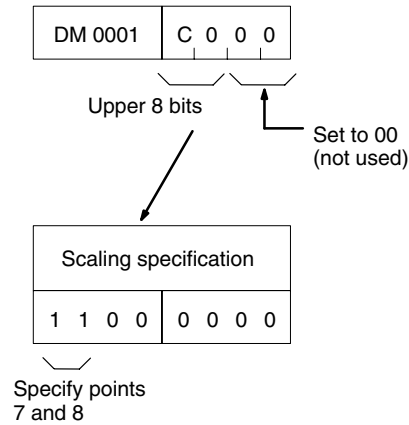

Note The data writing area extends to 26 words maximum. If some points are not used for mean value or scaling, as shown above, the area will be smaller. Set only the data which needs to be set according to the settings of the first two words (here it's DM 0000 and DM 0001).

Data Reading Area Allocation

Input point	Normal converted data	Peak value	BCD converted data
1	DM 0100	DM 0200	DM 0300
2	DM 0101	DM 0201	DM 0301
3	DM 0102	DM 0202	DM 0302
4	DM 0103	DM 0203	DM 0303
5	DM 0104	DM 0204	DM 0304
6	DM 0105	DM 0205	DM 0305
7	DM 0106	DM 0206	DM 0306
8	DM 0107	DM 0207	DM 0307

Disconnection Detect Flag: DM 0108

Ladder Programming Example Using C1000H

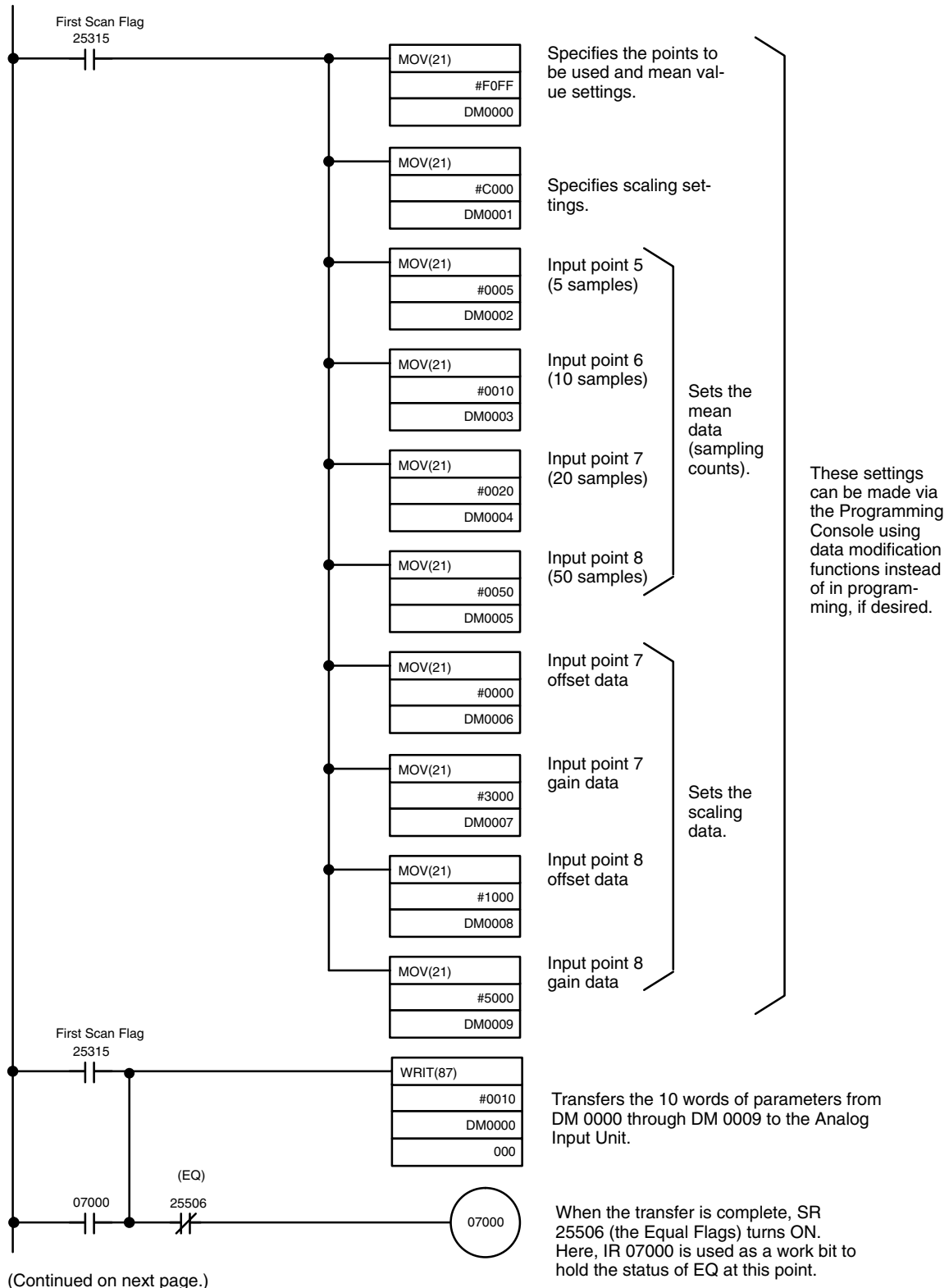

(Continued on next page.)

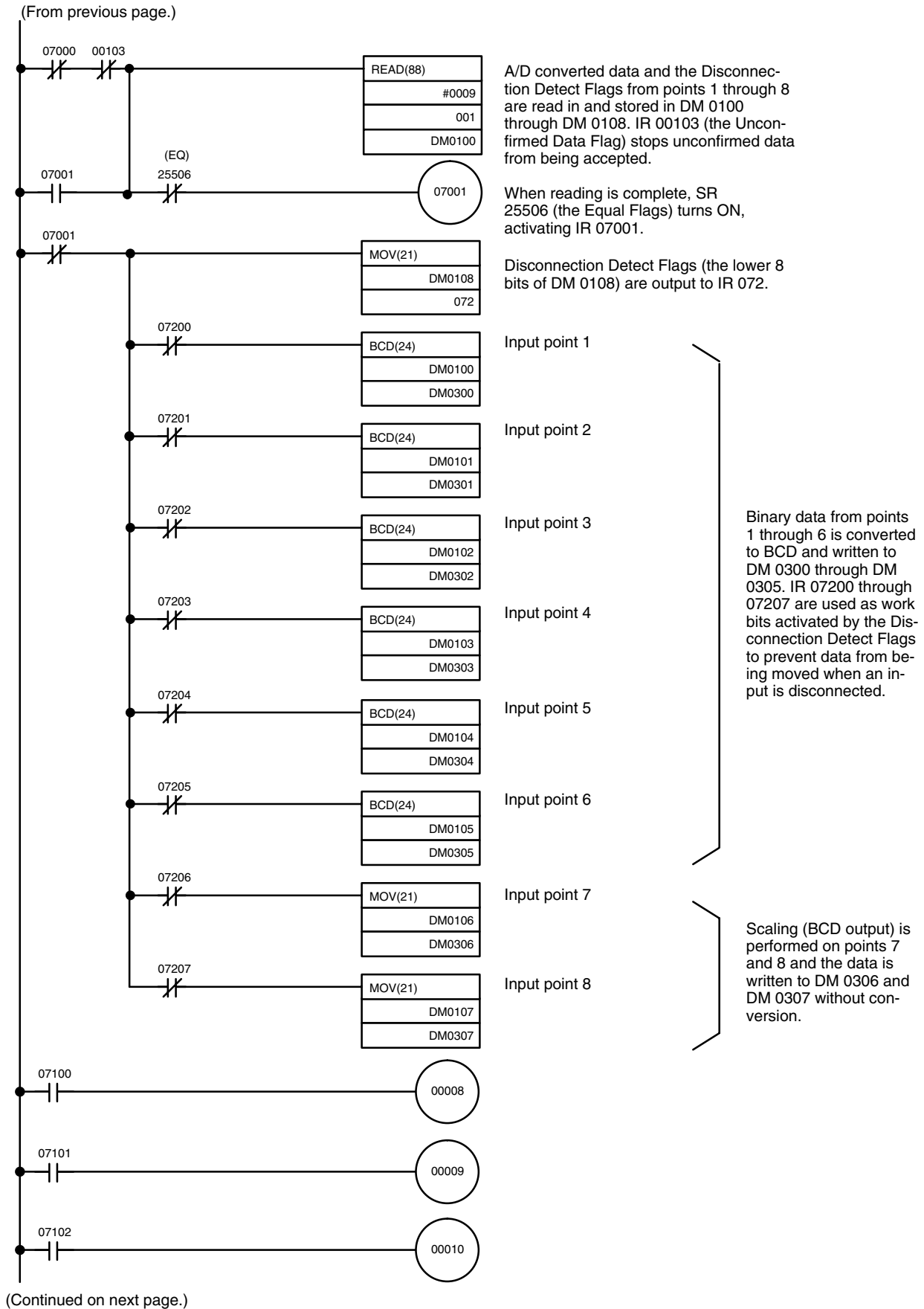

(From previous page.)

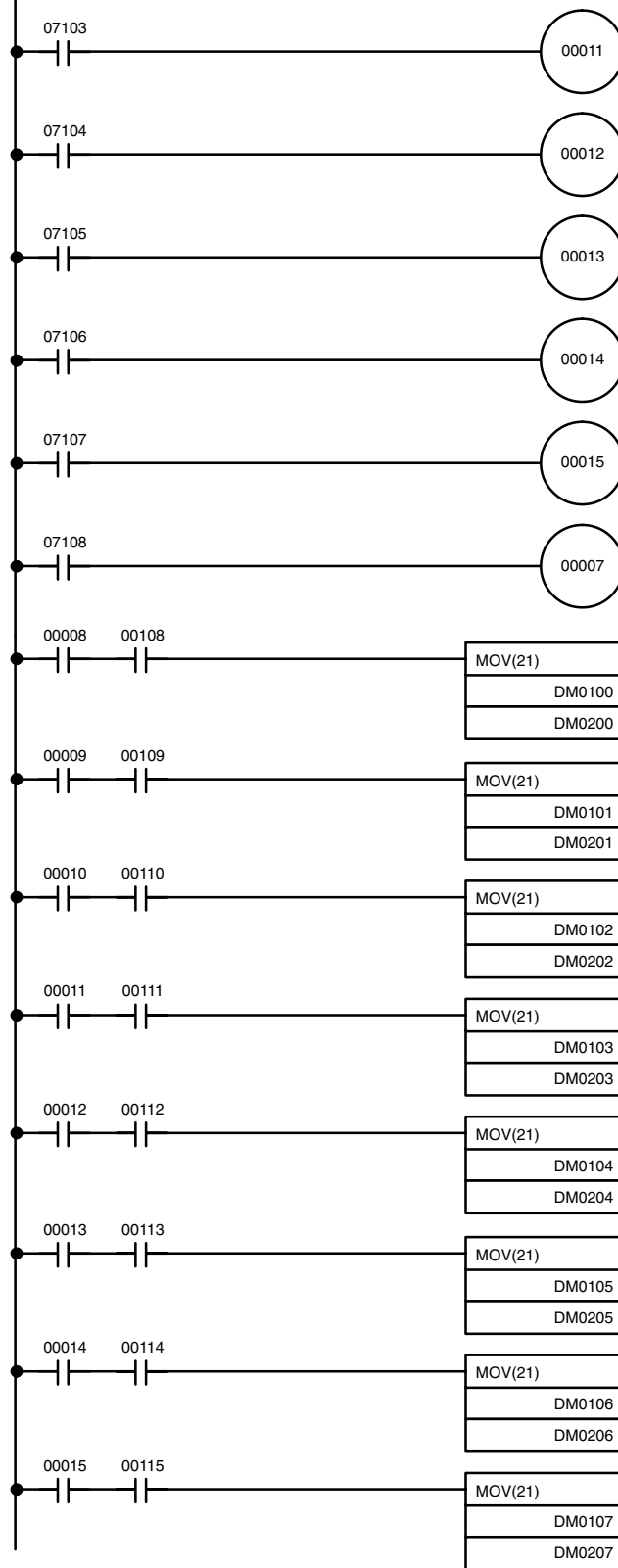

IR 0033 is used for peak values. IR 00008 through IR 00015 are used to activate the moving of the peak values into the desired storage locations. Turn ON the Peak Read Bits and check the Peak Flags to read the peak values (see above). IR 00007 is used as the Peak Reset Flag. Turn ON both the Peak Reset Bit and the Peak Read Bit to reset a peak value.

IR 00108 through IR 00115 are used as Peak Flags. When the input point data reaches a peak value, the flag corresponding to the input point will turn ON. When both the Peak Read Bit and Peak Flags are ON, the peak value, which will have been read at the last READ(87), will be written to DM 0200 through DM 0207.

CV/CVM1 Series Programming Examples

Because the CV/CVM1 Series offers higher processing speeds than the C Series, C Series programs may not run correctly if converted for the CV Series.

To use a program with the CV Series, the C500-AD101 Unconfirmed Data Flag (CIO n+1, Bit 03) must be inserted as a execution condition for the WRIT instruction.

I/O bit	Function
000103	C500-AD101 Unconfirmed Data
010000	Write Complete
010001	Write Complete Hold
010002	Read Complete
010100	Data 0 Disconnected
010101	Data 1 Disconnected
010102	Data 2 Disconnected
010103	Data 3 Disconnected
010104	Data 4 Disconnected
010105	Data 5 Disconnected
010106	Data 6 Disconnected
010107	Data 7 Disconnected

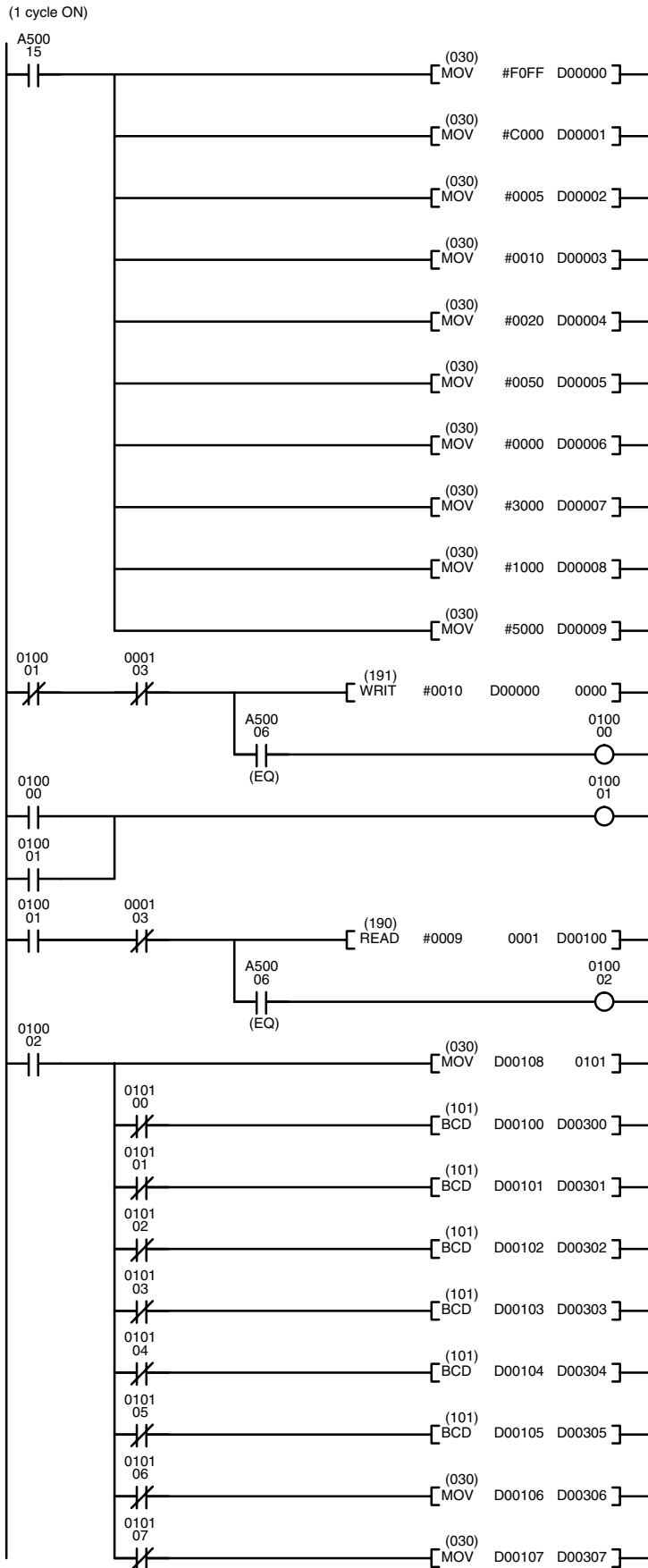

4-4 Four-word Operation

4-4-1 Communications with CPU Unit

The MOV instruction is used for data transfer between the C500-AD101 and the CPU Unit in four-word operation mode.

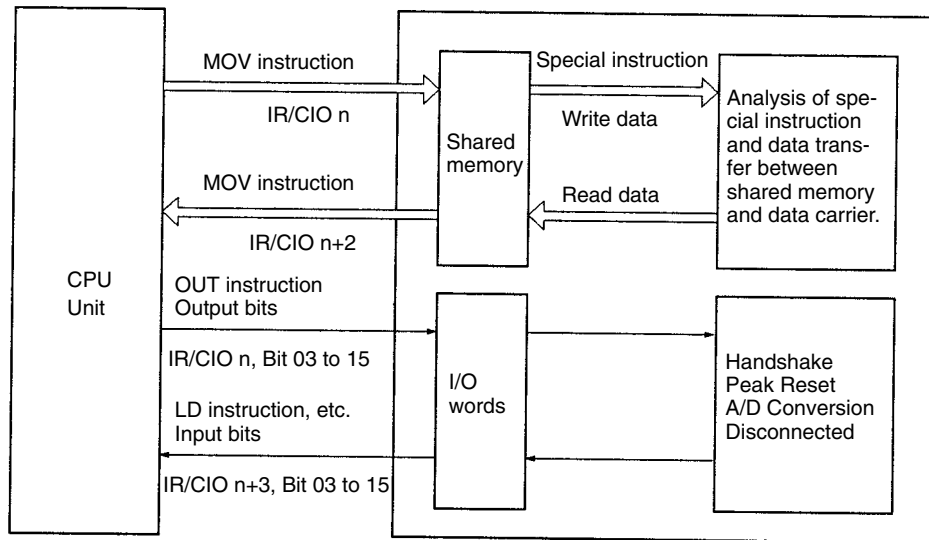

Always set four-word operation if the READ and WRIT instructions cannot be used because the CPU Unit does not support READ and WRIT or if the C500-AD101 is mounted to a SYSMAC BUS Slave Rack

Using the MOV instruction, I/O refresh is matched to the CPU Unit cycle time.

4-4-2 IR/CIO Bit Allocations

IR/CIO Bit Allocations

Bit	Word			
	Output		Input	
	IR/CIO n	IR/CIO n+1	IR/CIO n+2	IR/CIO n+3
00	Write data	Point 1 Control Bit	Read data	Point 1 Read Flag
01		Point 2 Control Bit		Point 2 Read Flag
02		Point 3 Control Bit		Point 3 Read Flag
03		Point 4 Control Bit		Point 4 Read Flag
04		Point 5 Control Bit		Point 5 Read Flag
05		Point 6 Control Bit		Point 6 Read Flag
06		Point 7 Control Bit		Point 7 Read Flag
07		Point 8 Control Bit		Point 8 Read Flag
08		Normal/Peak Control Bit		Disconnection Detect Flag
09		0		Normal/Peak Flag
10		0		0
11		0		0
12		Peak Reset Bit		0
13		A/D Conversion Bit		0
14		PC Write Completed Bit		A/D Read Completed Flag
15		PC Read Completed Bit		A/D Write Completed Flag

Point Control Bits

Turn ON one of the Point Control Bits to designate the desired input point when writing the number of sampling counts for the mean value and when reading binary-converted data. When using peak hold, turn OFF the A/D Conversion Bit. When not using peak hold, turn ON this bit.

Normal/Peak Control Bit

Turn ON this bit and the A/D Conversion Bit to read normal binary-converted values and turn OFF this bit and the A/D Conversion Bit to read peak values.

Peak Reset Bit

Turn ON this bit to reset an input point for which the peak value is being read.

A/D Conversion Bit

Turn ON this bit when reading normal data, and turn it OFF when reading peak values or writing the number of sampling counts for the mean value.

Point Read Flags

One of these flags turns ON to designate the input point for which data is being read.

Disconnection Detect Flag

When the signal line of the point designated by the Point Read Flags is burned out or disconnected, this flag turns ON. The offset must be set to at least 1 V (4 mA) for this flag to work.

Normal/Peak Flag

This flag turns ON when the data being read is normal data and turns OFF when the data is the peak value.

Note The scaling function does not work with 4-word operation.

4-4-3 Programming Examples

Example programs are shown below for four-word operation using the C1000H. Create programs as described below for a CPU Unit that does not support the I/O READ and I/O WRITE instructions (READ and WRIT) or when the Analog I/O Unit is mounted to a SYSMAC BUS Slave Rack.

IR Bit Allocation

The C500-AD101 is allocated IR 000 to IR 003.

Bit	Words					
	Output			Input		
	000	001		002	003	
00	Write data	Input point designation	Point 1	Read data	Read data point designation	Point 1
01			Point 2			Point 2
02			Point 3			Point 3
03			Point 4			Point 4
04			Point 5			Point 5
05			Point 6			Point 6
06			Point 7			Point 7
07			Point 8			Point 8
08		Normal/Peak Control Bit		Disconnection Detect Flag		
09		0		Normal/Peak Flag		
10		0		0		
11		0		0		
12		Peak Reset Bit		0		
13		A/D Conversion Bit		0		
14		PC Write Completed Bit		A/D Read Completed Flag		
15	PC Read Completed Bit		A/D Write Completed Flag			

DM Area Allocation

Input point	Mean value sample count					Normal converted data	Peak converted data
1	DM 0000	0	0	0	0	DM 0100	DM 0200
2	DM 0001	0	0	0	0	DM 0101	DM 0201
3	DM 0002	0	0	0	0	DM 0102	DM 0202
4	DM 0003	0	0	0	0	DM 0103	DM 0203
5	DM 0004	0	0	0	5	DM 0104	DM 0204
6	DM 0005	0	0	1	0	DM 0105	DM 0205
7	DM 0006	0	0	2	0	DM 0106	DM 0206
8	DM 0007	0	0	5	0	DM 0107	DM 0207

Mean value at input points 5 to 8.

Programming Using Only One Point

In four-word operation, a program uses the MOV instruction and the PC and A/D Read/Write Complete Flags.

Initially, set the mean value sampling count for the input point. If the mean is not required, set the sampling count to zero or do not create a program to write the mean value.

Programming Concept

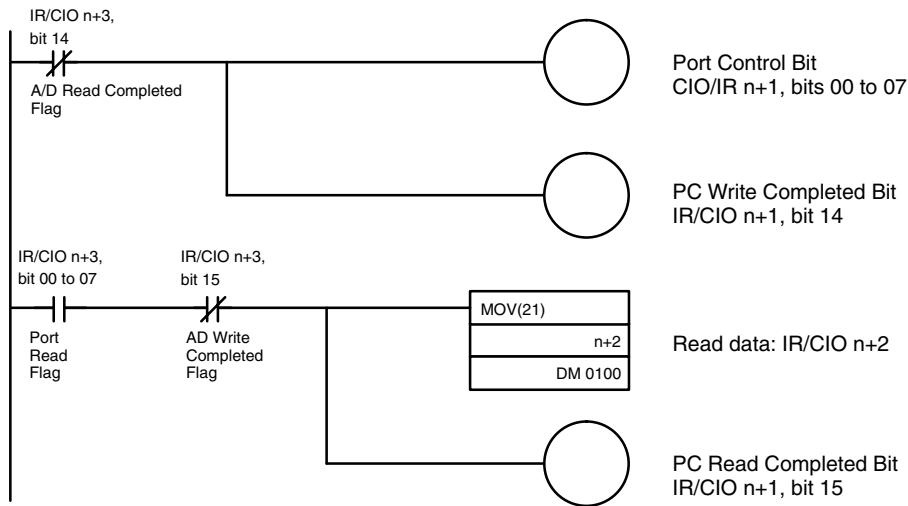

Timing Chart when Using Four Points

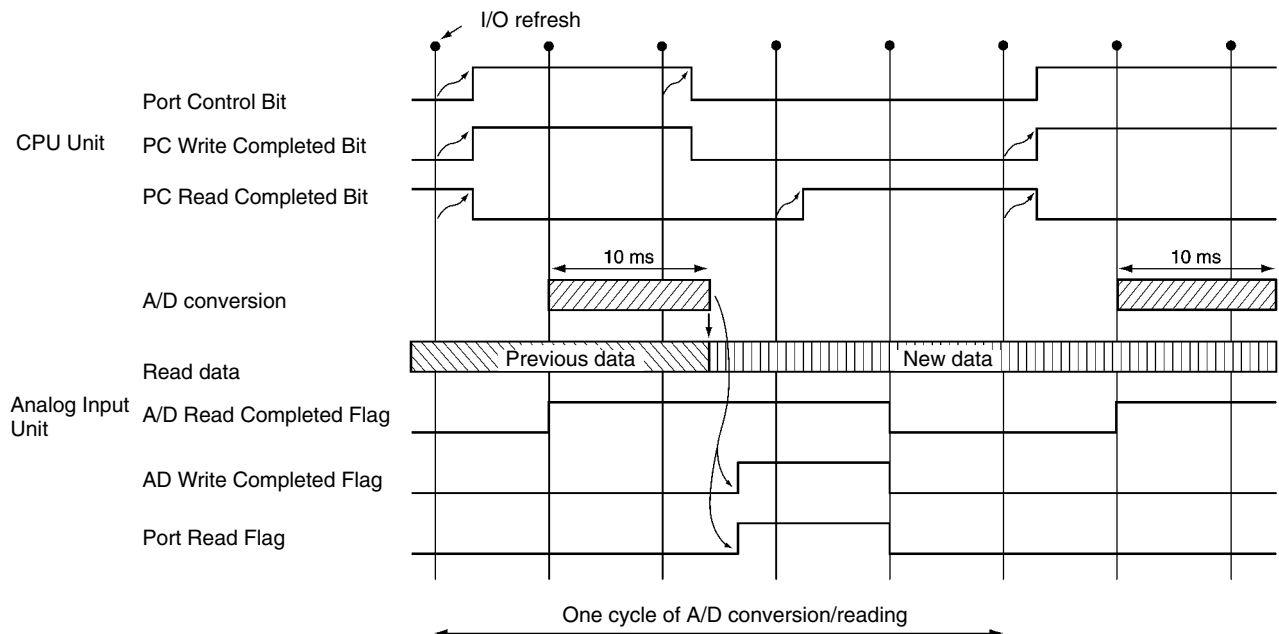

Programming Using Only Point 1

The following program is used when only one of the input points is used.

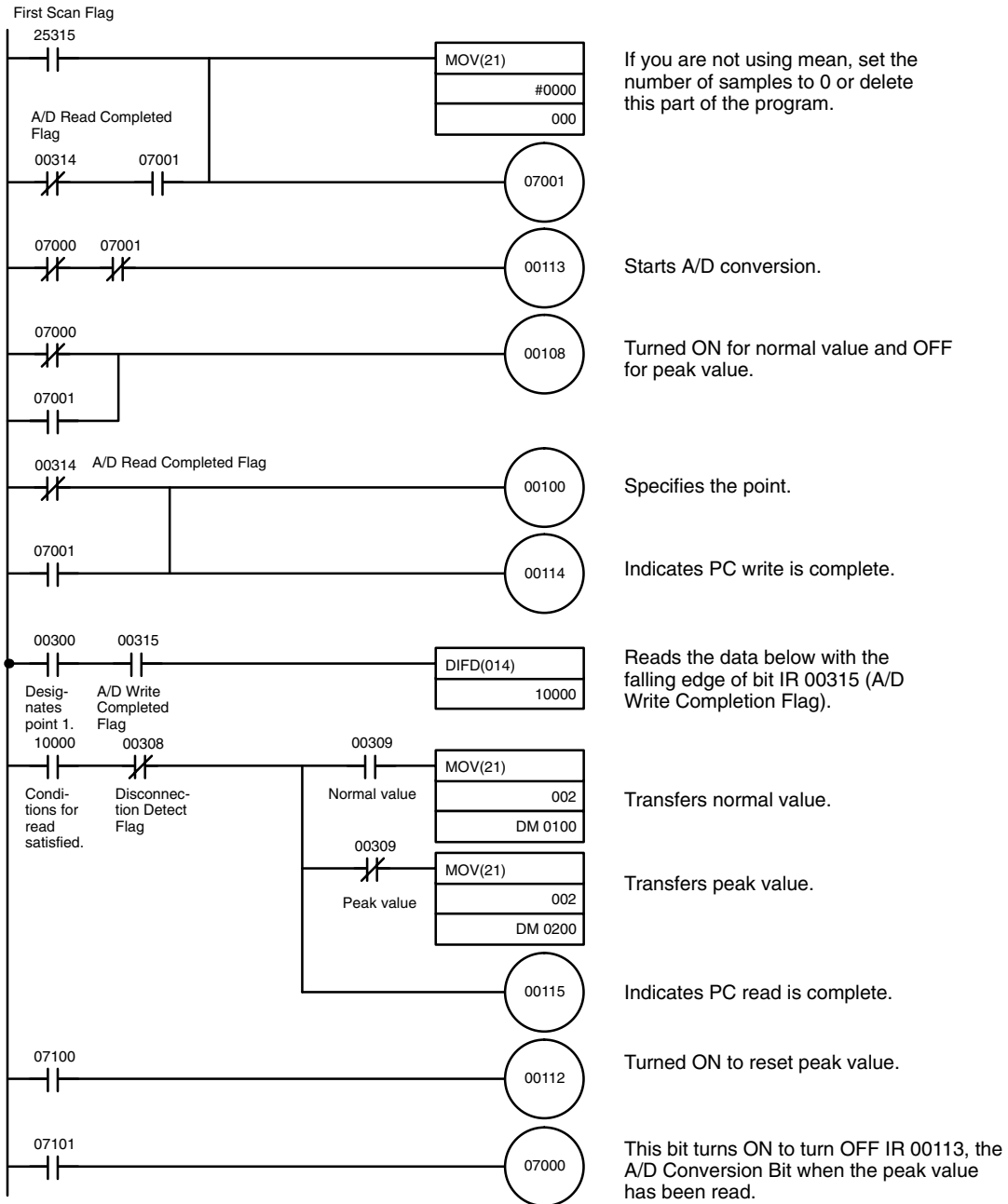

Programming Using All 8 Points

The following program can be used when all eight input points are being used.

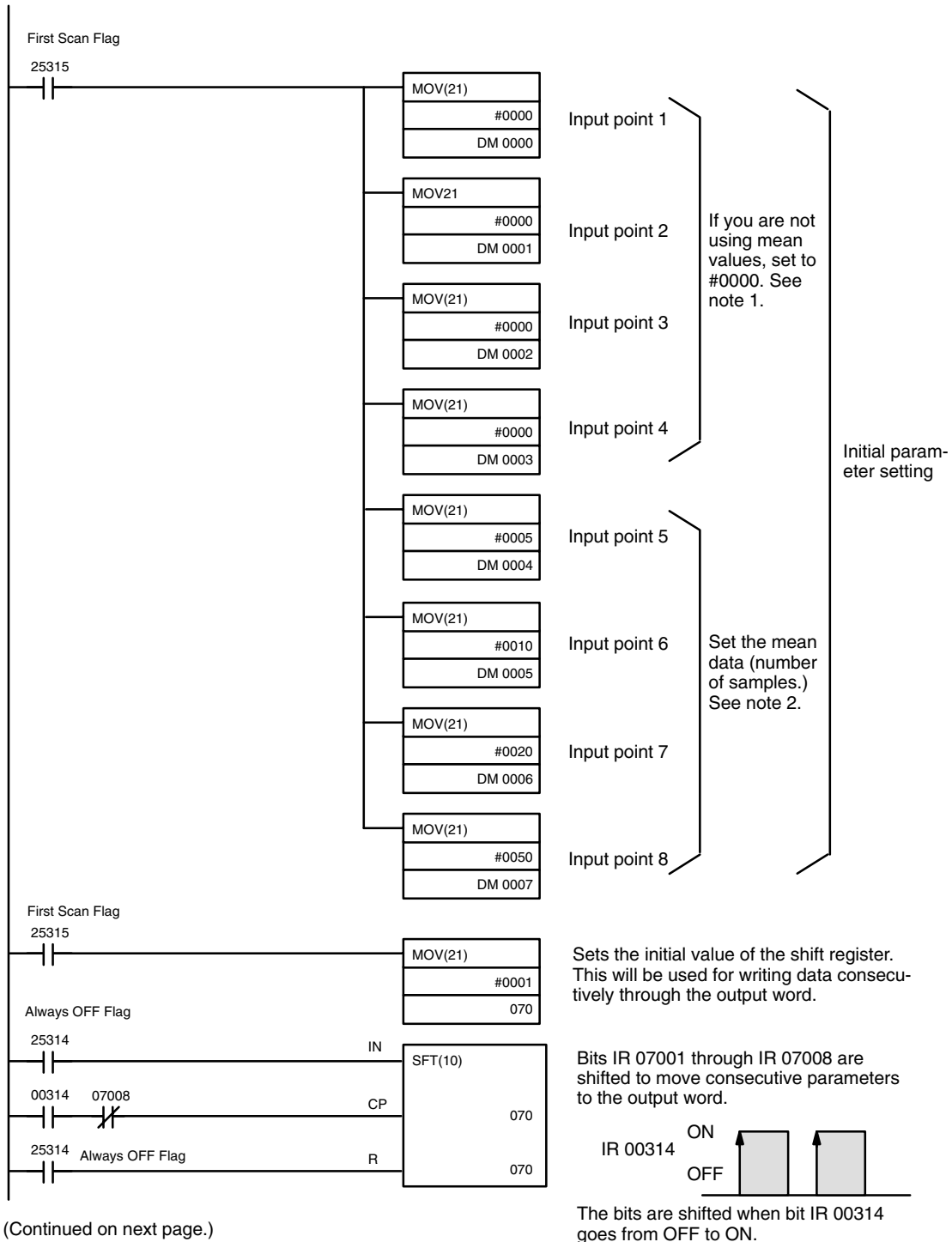

(Continued on next page.)

- Note**
1. When mean is not used, no setting is necessary. The above example includes settings for all points to allow for easy modification.
 2. Mean processing starts after the points are specified. It takes 10 ms x (number of samples) for the data to be output.

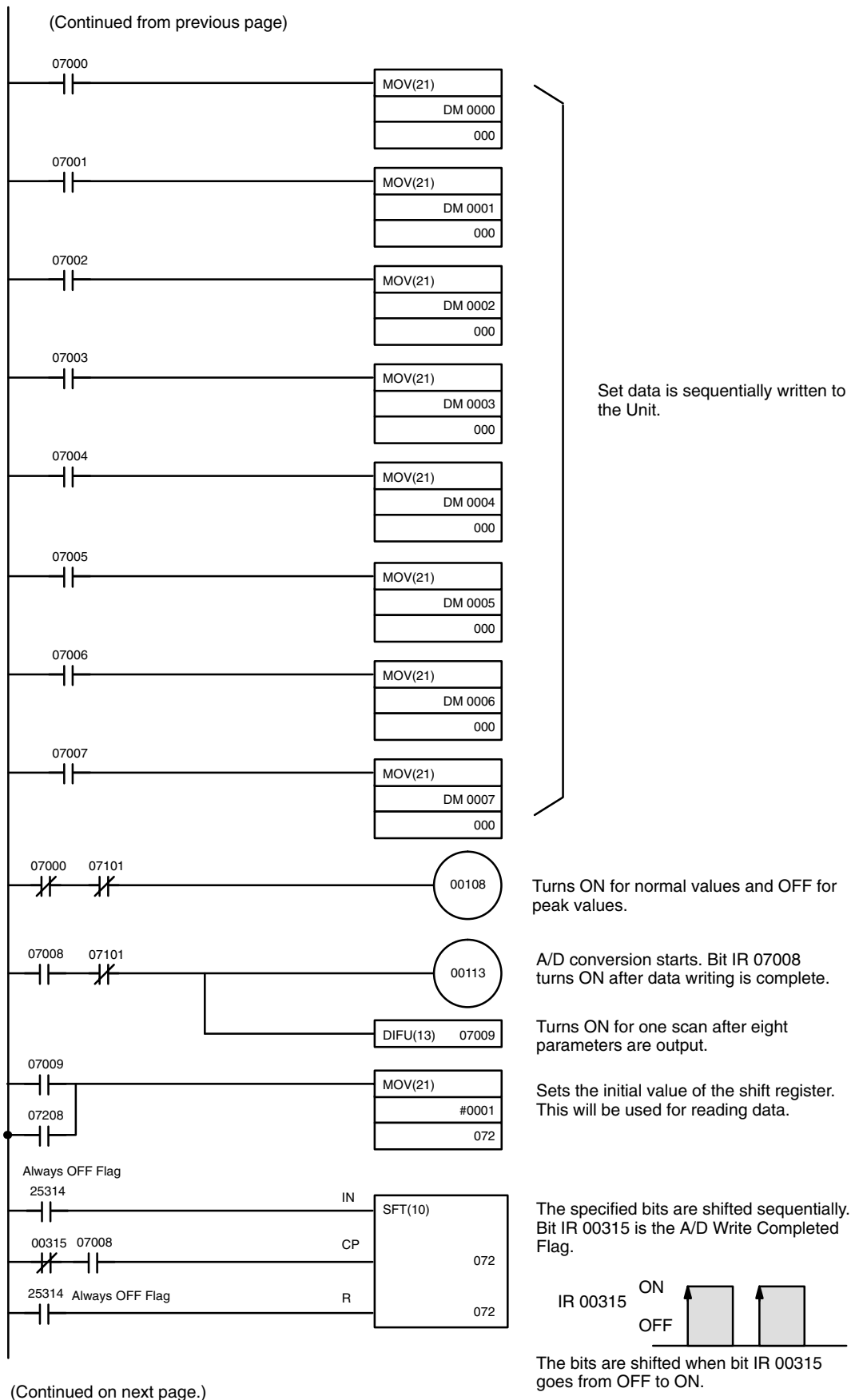

(Continued on next page.)

(Continued from previous page)

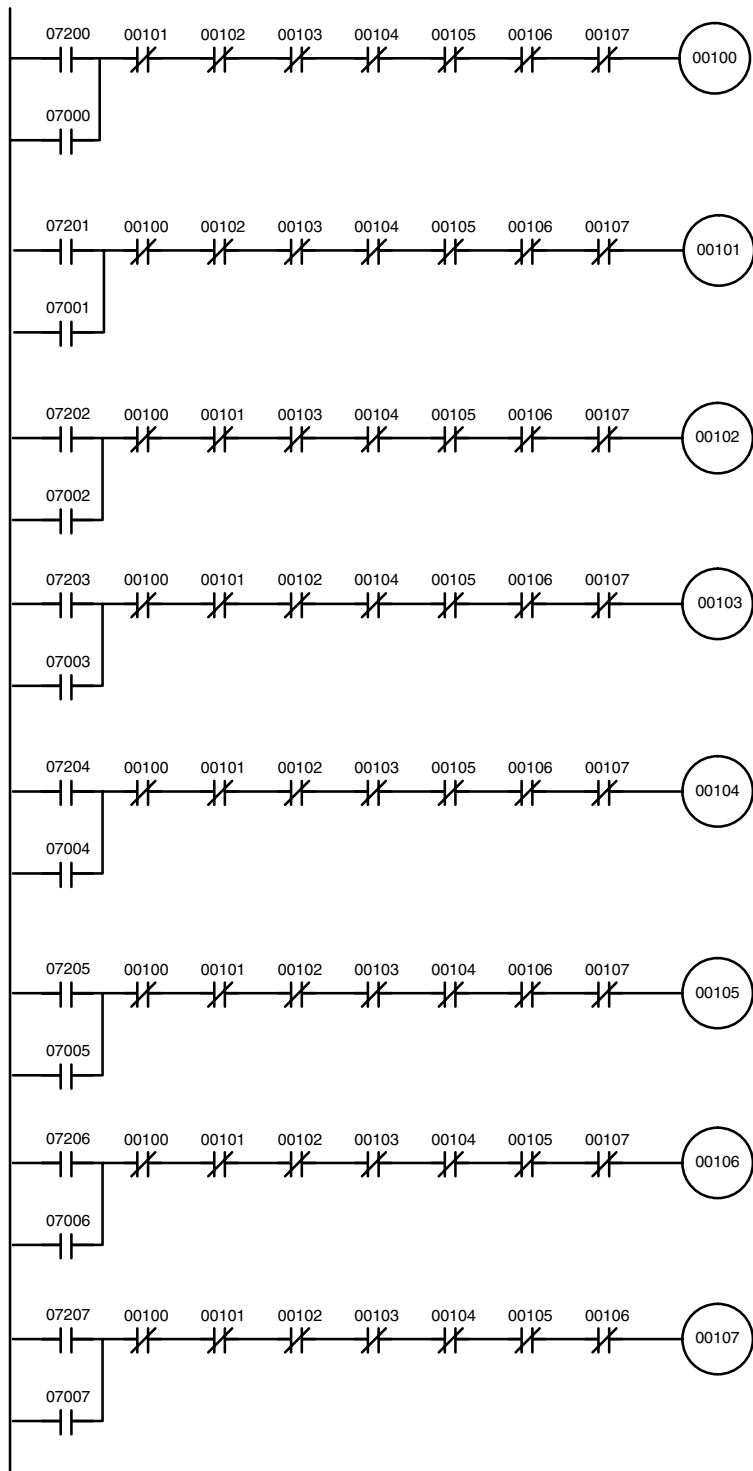

Specify the points to be read. These are set up so that only one of the operand of these OUT's is ON at the same time.

(Continued on next page)

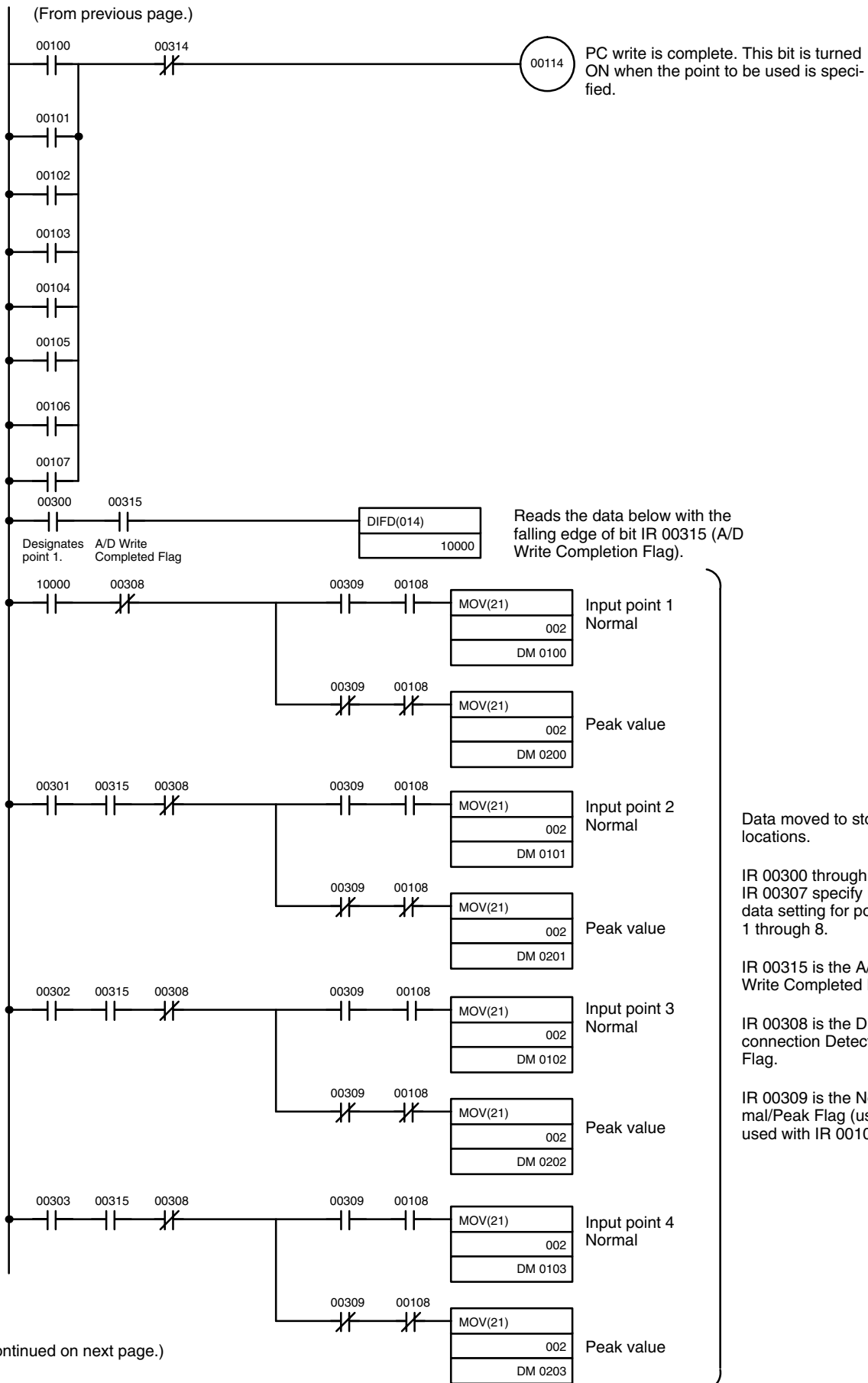

(Continued on next page.)

(From previous page.)

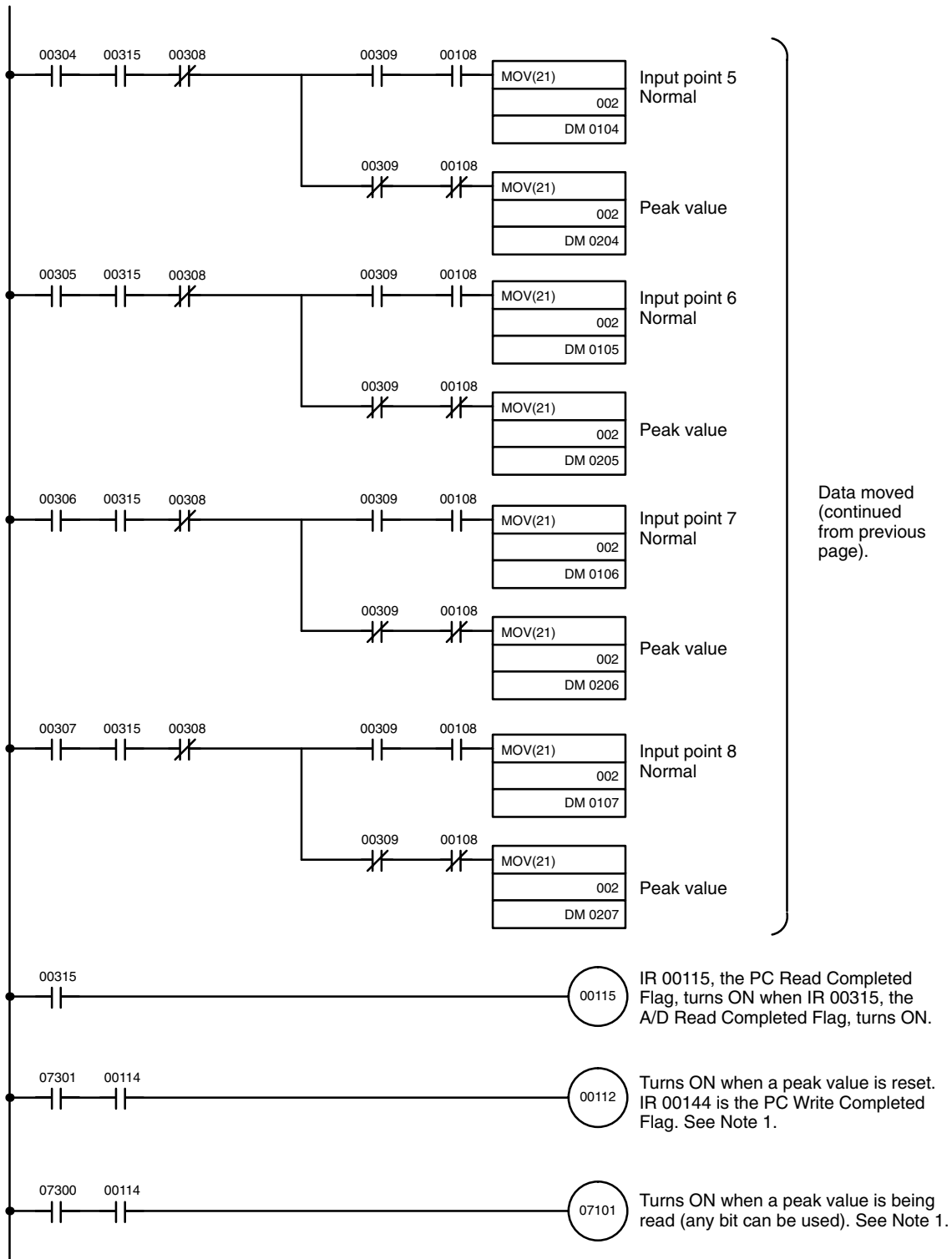

- Note**
1. The peak value is reset when the Peak Reset Flag turns OFF.
 2. The peak value is held while the Peak Flag is ON. IR 00114 initiates the reading of new peak values while IR 07301 is ON.

SECTION 5

C500-AD501 Analog Input Unit

This section describes information on the C500-AD501 Analog Input Unit, including the specifications, connections, I/O word allocations, and applications.

5-1	Specifications and General Information	62
5-1-1	Specifications	62
5-1-2	Theory of Operation	64
5-1-3	Unit Data Format	64
5-1-4	Functions	65
5-1-5	Description of Parts	66
5-1-6	Indicators	67
5-1-7	DIP Switches and Slide Switches	68
5-1-8	Block Diagram	69
5-2	Quick Start Procedure	69
5-3	Installation, Settings, and Wiring	70
5-3-1	Unpacking the Unit	70
5-3-2	Installation Requirements	70
5-3-3	Setting Input Ranges	70
5-3-4	Wiring	72
5-3-5	Wiring Diagrams	73
5-4	Data Exchange with CPU Unit	76
5-4-1	Communications with the CPU Unit	76
5-4-2	IR/CIO Bit Allocations	78
5-5	Memory Map	80
5-5-1	Error Flags	80
5-5-2	Overview	81
5-5-3	Memory Map Details	82
5-5-4	Using the Unit Memory Map Configuration Sheet	87
5-6	Functions	87
5-6-1	Overview	87
5-6-2	Scaling	88
5-6-3	Averaging	91
5-6-4	Filtering	91
5-6-5	Peak Hold	92
5-6-6	High/Low Alarms	92
5-6-7	EEPROM Functions	93
5-7	User Programming Examples	94
5-7-1	Basic Programming	94
5-7-2	Using the Unit Configuration Worksheet	94
5-7-3	Using the Pointer Word in the Unit Memory Map	95
5-7-4	Writing Data to the Unit	95
5-7-5	Reading Data from the Unit	98
5-7-6	Typical Programming Examples	100

5-1 Specifications and General Information

5-1-1 Specifications

General Specifications

All general specifications of the C500-AD501 Analog Output Unit conform to those of the C Series.

Performance Specifications

Item		Specification
Number of analog inputs		16 points, differential
Input signal range (See note 1.)	Voltage input	0 to 5 VDC, 0 to 10 VDC, -5 to 5 VDC, -10 to 10 VDC
	Current input	0 to 20 mA, -20 to 20 mA
Advanced functions		Scaling, alarms, averaging, filtering, peak hold. Select and configure per input point
Resolution		1/4096 (12 Bit) 0.02%
Accuracy	Voltage input	±0.08% at 25°C ±0.15% over 0° to 55°C with 95%
	Current input	±0.18% at 25°C ±0.25% over 0° to 55°C with 95% *Includes internal 0.1% 250 Ω resistor
Conversion time (See note 2.)		25 ms minimum, all 16 inputs
Input impedance	Voltage input	1 MΩ minimum
	Current input	250 Ω
Maximum input signal	Voltage	± 15 VDC
	Current	± 30 mA
Reporting data format		Signed BCD 2's complement binary Set from CPU Unit or serial port
Number of I/O words		2
PC communications		I/O READ and I/O WRITE instructions
Internal memory		RAM EEPROM for memory map storage
Front window indicators		Run, error, range, comm error, transmit/receive
Input connector		OMRON 38-terminal removable connector C500-PAR-PTC 38
Vibration resistance	Durability	10 to 54.8 Hz at 0.25 mm amplitude in X, Y and Z directions for 12 times in 10 min. 54.8 to 300 Hz at 3G in X, Y and Z directions for 12 times in 10 min.
	Malfunction	10 to 61.2 Hz at 0.1 mm amplitude in X, Y and Z directions for 4 times in 8 min. 61.2 to 150 Hz acceleration at 1.5 G in X, Y and Z directions for 4 times in 8 min.
Impact resistance	Durability	30 G in X, Y and Z directions three times each direction
Isolation		Optical isolation between input terminals and PC: 1,500 VDC
Power consumption		1.2 A from Backplane; 6.2 W max.
Dimensions		34.5 x 250 x 120 mm (W x H x D)
Weight		700 g max.

- Note**
1. The input signal ranges are set using the DIP switches and slide switches.
 2. Using special functions will increase the A/D conversion time.

Input Specifications

The input specifications of the C500-AD501 Analog Input Unit are shown below.

Binary (Hex) Mode

A/D converted data

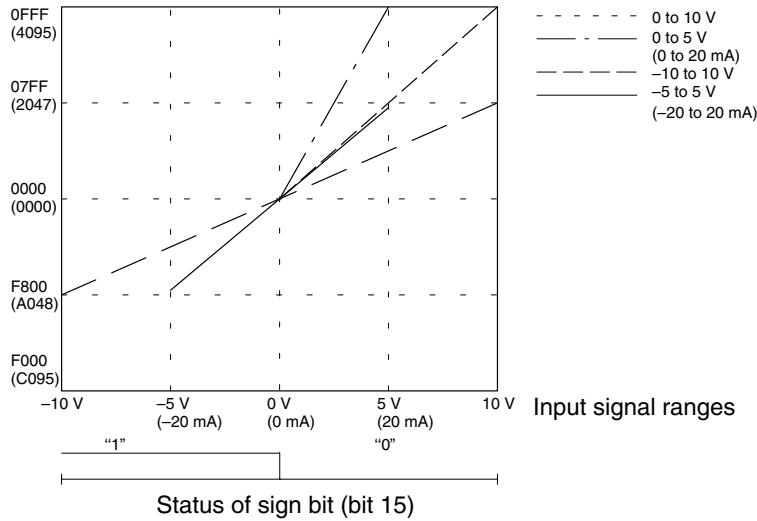

A/D converted data

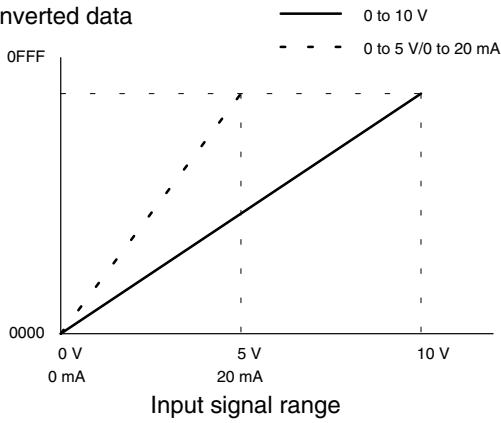

A/D converted data

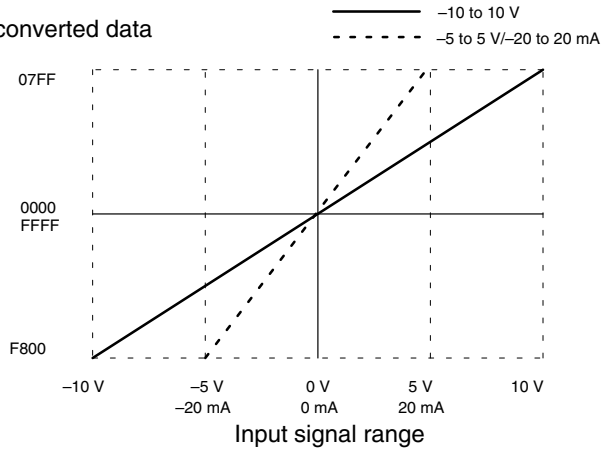

BCD Mode

A/D converted data

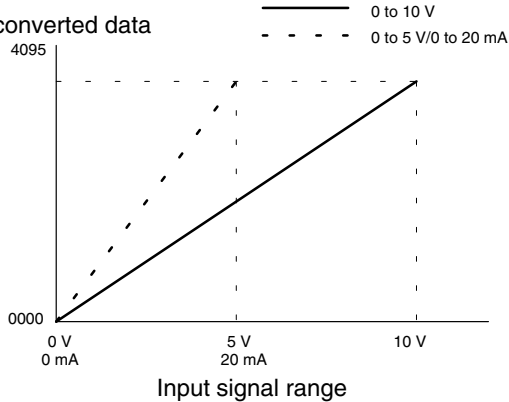

A/D converted data

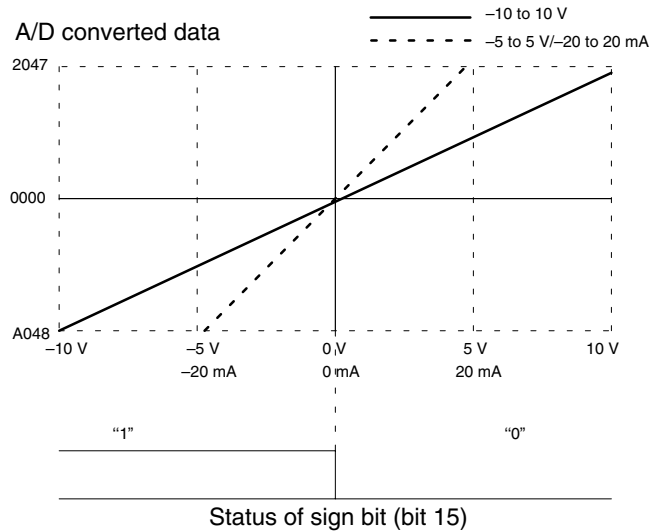

5-1-2 Theory of Operation

The Unit converts field signals (voltage and current) to digital values that are available to the CPU Unit's ladder program for processing. A microprocessor allows the Unit to perform advanced functions on the converted data prior to being accessible to the CPU Unit. The Unit's microprocessor reduces the amount of ladder logic required to perform functions such as scaling, averaging, filtering, peak hold, and alarms. These functions are executed in the Unit which reduce the burden on the CPU Unit.

5-1-3 Unit Data Format

The Unit can be configured to report (output) data in two different formats. They are signed BCD and 2's Complement Binary. These formats can be selected per input point with the default set to BCD. In addition, the Unit memory map consists of 16 bit words that contain either data or are bit oriented as flags or bits. The following conventions are used when describing the Unit memory map locations and their functions.

Data in the Unit memory map can be formatted in either signed BCD or 2's complement binary. All values for a specific input point must be in the same format. Some values are always entered in unsigned BCD. Refer to *5-5-2 Overview* for valid data ranges for all Unit memory map locations.

Format type	Decimal range	Memory map format
Signed BCD	-7999	F999 (Bit 15 is the sign bit)
	7999	7999
2's Complement Binary	-32767	8001
	-1	FFFF
	0	0000
	32767	7FFF

5-1-4 Functions

The C500-AD501 Analog Input Unit offers maximum application flexibility and high performance processing by combining the latest in analog and software technology to provide the following features.

- Flexible configuration options
- High point density
- High accuracy and conversion speed
- Advanced functions
- Advanced digital state-of-the-art calibration thereby eliminating potentiometers, and no need to perform calibrations during the life of the Unit.

The following table lists the functions of the C500-AD501.

Function	Description
Input point enable/disable settings	Only the input points that will be used can be enabled, preventing processing for unused points to increase processing speed.
Input signal range settings	The input signal range can be set separately for each input point.
Binary/BCD settings for output data	The data format for converted and processed data can be set to either binary or BCD.
Pointer word	The pointer word can be set to specify the first word to be read or written using the I/O READ or I/O WRITE instructions. Processing speed is increased because only the required words are read or written.
Scaling	Converted data can be converted full-scale between upper and lower limits sets by the user.
Filtering	A filter can be set to prevent the output data from changing rapidly even if the input value changes rapidly. This function can be used to reduce errors that can occur as a result of inductive noise.
Averaging	An averaging function can be used to output an averaged based on a specific number of samples. This function can be used to reduce errors that can occur as a result of noise on the analog input signal.
Peak hold	The peak hold function enables outputting the maximum converted value.
High/low alarms	High and low limits can be set to turn ON High or Low Alarm Flags when the converted data exceeds one of the limits.
Over-range and under-range errors	An Out-of-range Error Flag is turned ON when the input signal exceeds the set input signal range.
EEPROM parameter storage	Parameters can be stored in EEPROM so that they are used automatically at startup.

Refer to *5-6 Functions* for details on special functions.

5-1-5 Description of Parts

The parts of the Unit are identified below.

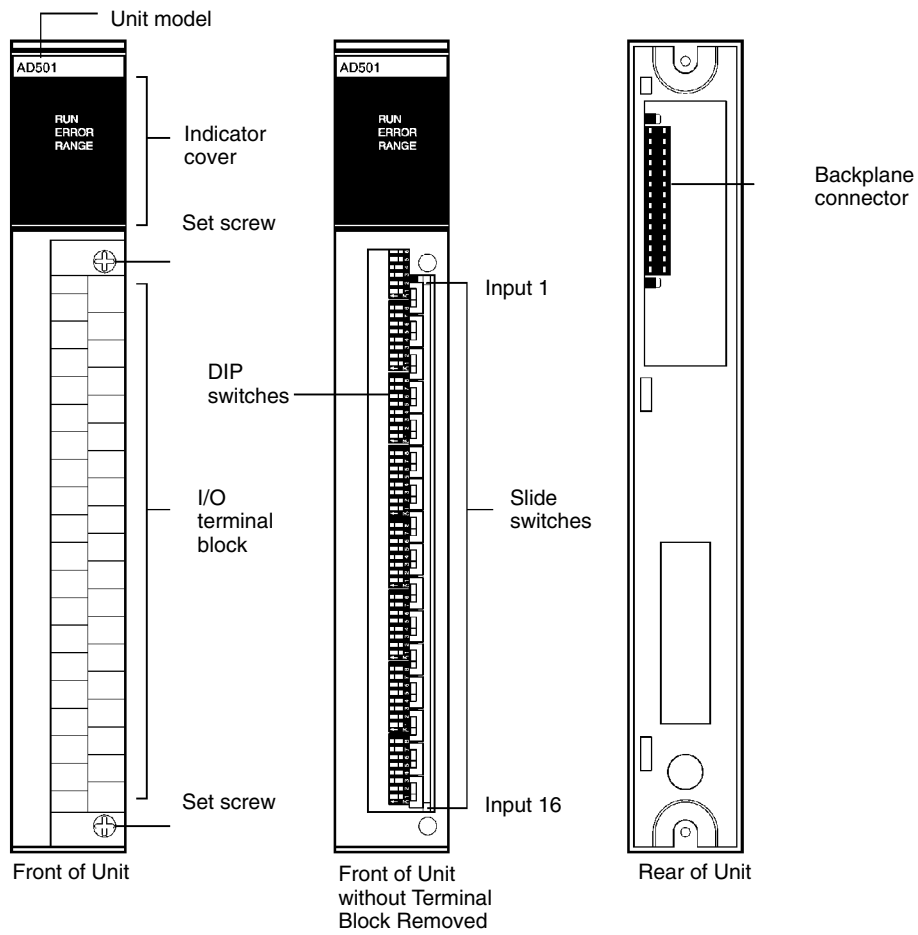

5-1-6 Indicators

Indicators	Function
RUN (Green)	Unit is operating correctly. If an error occurs, this indicator turns OFF and the Unit stops operating. The indicator flashes when the number of write operations to EEPROM exceeds 10,000. If the indicator flashes, replace the Unit.
ERROR (Red)	An internal diagnostic error or an out-of-range error occurred.
RANGE (Red)	An input signal is outside the selected range.

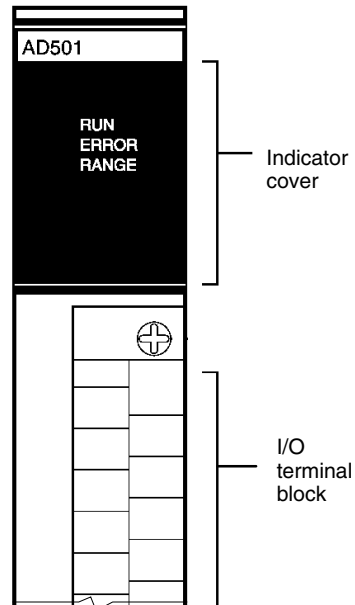

5-1-7 DIP Switches and Slide Switches

The DIP switches and slide switches are located beneath the detachable terminal block. To set these switches, first remove the upper and lower set screws and then remove the terminal block.

The locations of the DIP switches and slide switches are shown in the following diagrams. The DIP switch pins are divided into groups of four pins each (pins 1 to 4 and pins 5 to 8). They are used to set inputs 1 to 16 in order from the indicator cover. One slide switch is allocated for each input. They are used to set inputs 1 to 16 in order from the indicator cover.

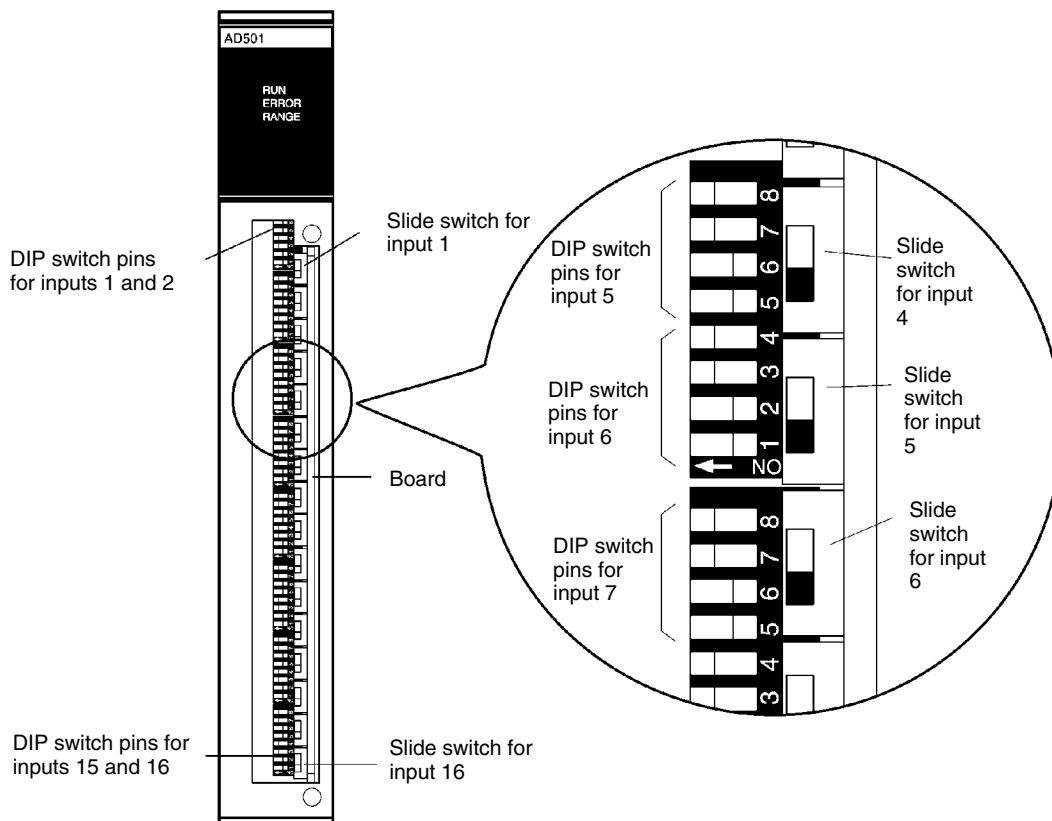

5-1-8 Block Diagram

The following diagram shows the basic internal connections of the Unit.

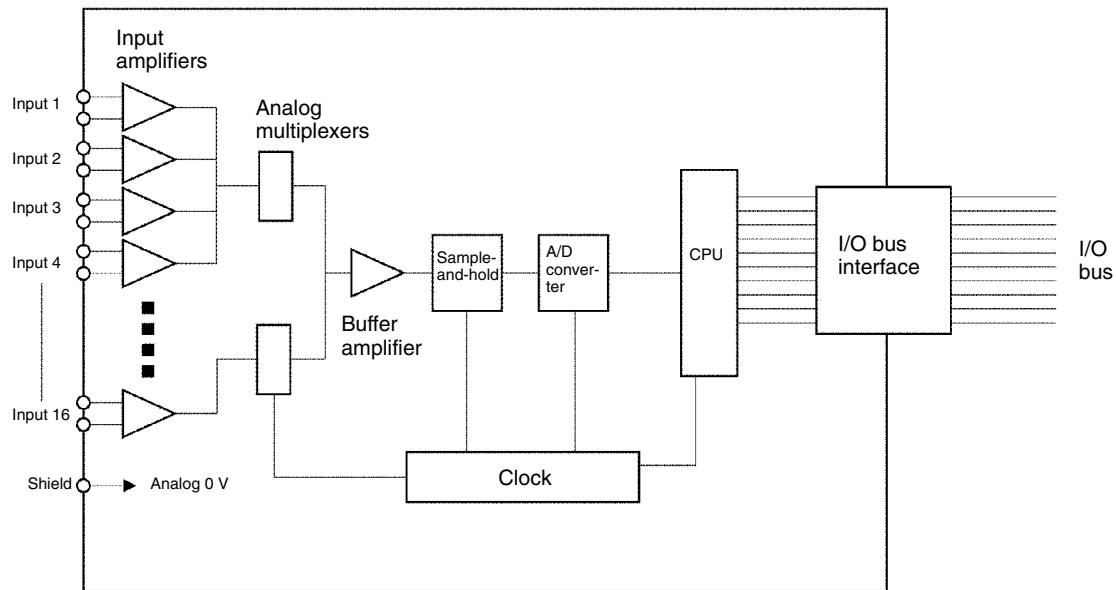

5-2 Quick Start Procedure

The following steps are used as a quick reference guide when installing and setting up the Unit.

- 1, 2, 3...**
1. Unpack the Unit.
 2. Replace the connector on the Unit.
 3. Set DIP switches and slide switches.
 4. Install the Unit on the Backplane.
 5. Wire the I/O terminals.
 6. Write down settings in the configuration worksheet.
 7. Turn ON the power supply to the Unit.
 8. Verify default ladder programs.
 9. Check Unit indicators.

5-3 Installation, Settings, and Wiring

5-3-1 Unpacking the Unit

To unpack the Unit, open the shipping carton and slide out the corrugated insert containing the Unit. Remove the Unit from the insert, making sure to retain the installation slip which accompanies the Unit. Be sure to keep the shipping carton and corrugated insert, in the event it should become necessary to return the Unit for service.



Caution The components on the C500-AD501 Analog Input Unit can be damaged by static electricity. Static control precautions should be observed when unpacking and handling the Unit during installation and setup.

5-3-2 Installation Requirements

Signal Requirements

Before setting the Unit input ranges and installing the Unit to the Backplane, make sure to review the application requirements, voltage or current modes, and input cable configuration. Analog signal cables generally have two signal wires which are labeled plus (+) and minus (-). They may also have an optional common wire and/or shield wire. Use the configuration worksheet in Appendix A to record Unit settings.

Power Consumption

The Unit uses 5 volt power from the PC power supply. The maximum current consumption is 1.2 amps. Refer to the *Installation Guide* for your PC to determine total system power requirements.

Unit Mounting Locations

The Unit uses the I/O READ and I/O WRITE ladder instructions to communicate with the CPU Unit. Each Unit occupies two I/O words in the I/O table. The Units may be located on the following racks.

- CPU Rack
- CV-series CPU Expansion Rack
- Local Expansion Rack
- SYSMAC BUS/2 Slave Rack

The Unit cannot be mounted to a SYSMAC BUS Slave Rack.

There are normally no restrictions to the number of Units that can be mounted to the Racks as long as the power supply capacity is not exceeded. Refer to page 78 for special restrictions on SYSMAC BUS/2 Slave Racks.

5-3-3 Setting Input Ranges

The C500-AD501 Analog Input Unit has six input signal ranges. The input signal range is set for each input by setting a DIP switch. The input signal ranges and DIP switch settings are listed below. Set the voltage/current input selection at the same time using the slide switch.

Slide switch setting

Input range	DIP switch pin settings				Slide switch settings
	5	6	7	8	
	1	2	3	4	
0 to 5 VDC	OFF	OFF	ON	ON	Voltage input
0 to 10 VDC	OFF	OFF	OFF	OFF	
-5 to 5 VDC	ON	ON	ON	ON	
-10 to 10 VDC	ON	ON	OFF	OFF	
0 to 20 mA	OFF	OFF	ON	ON	Current input
-20 to 20 mA	ON	ON	ON	ON	

Note DIP switch and slide switch settings are enabled when the power supply to the PC is turned ON.

Follow steps 1 through 5 to set current or voltage range for each input point.

1. Remove the I/O terminal block in the front of the Unit by backing out the captive screw at the top and bottom of the block, then pull off the terminal block.
2. Set the input range for each input. An input range is set using the corresponding DIP switch pins and slide switch. (Each DIP switch is used to set two input ranges.)

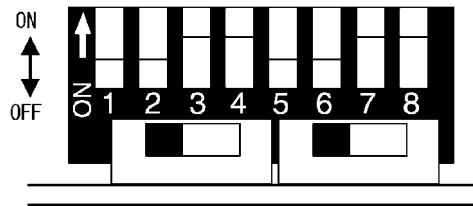

3. The DIP switch pins are ON when they are up (i.e., in the direction of the arrow) and OFF when they are down. The slide switch sets a voltage input when it is on the left and a current input when it is on the right.

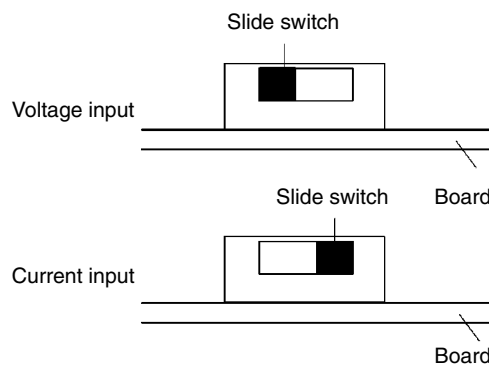

4. Use the Configuration Sheet in Appendix A to record Unit settings.
5. After settings are made, reinstall the I/O terminal block and tightening the captive screws.

5-3-4 Wiring

Wiring is accomplished at the terminal connectors or also referred to as terminal blocks. To access the terminal connectors proceed as follows.

- 1, 2, 3... 1. Insert each wire in the appropriate connector.
2. Secure each wire with the terminal screw.

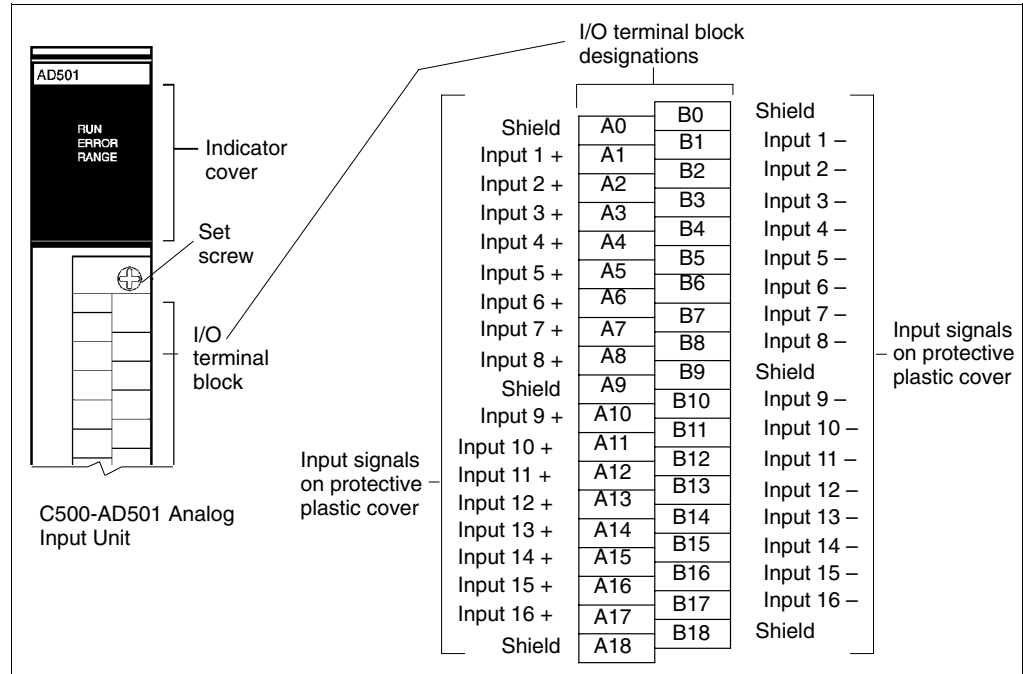

5-3-5 Wiring Diagrams

The Unit can accept a variety of input signals. The following diagrams show the various input signal wiring configurations.

Unit Front End

The diagram below is a simplified schematic of the front end of the Unit.

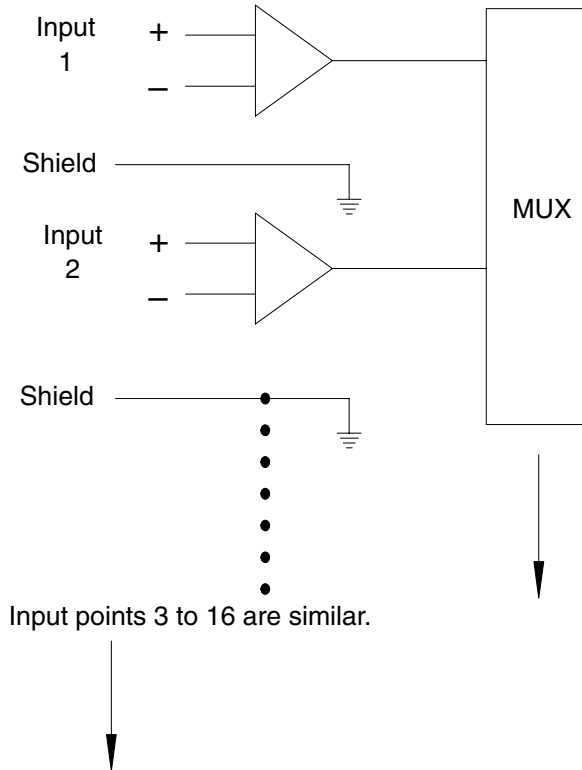

Note Shield terminals are not connected to the chassis ground of the PC Rack. They are connected to the internal analog ground plane of the Unit.

Single-ended Input with Shield (+, Common, Shield)

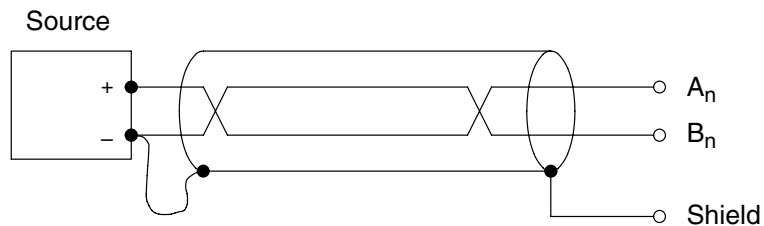

Differential Input with Shield (+, -, Shield)

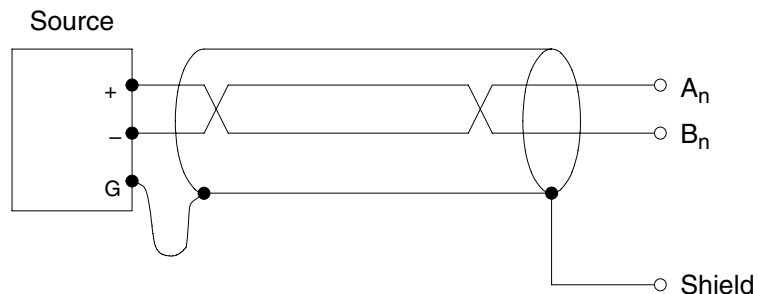

Note Only one ground is connected from this source as a reference for the Unit.

Single-ended and Differential Inputs on the Same Unit

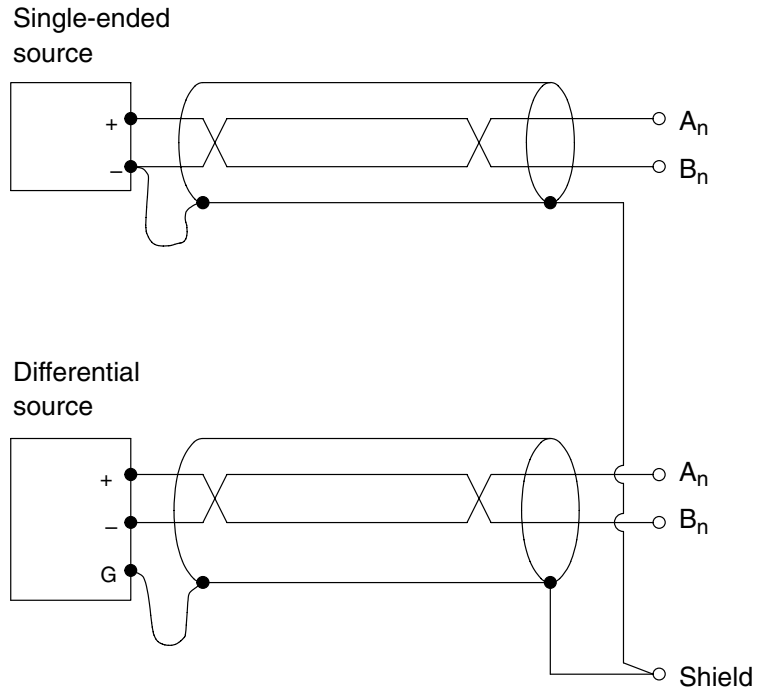

- Note**
1. For best results, OMRON recommends using only shielded, twisted-pair cable. Shields should be connected in a star fashion to the shield terminal.
 2. Shield terminals are not directly connected to chassis ground of the Rack. They are used as a floating reference for the isolated analog ground plane in the Unit.

Differential Source with Multiple Points (Single Reference)

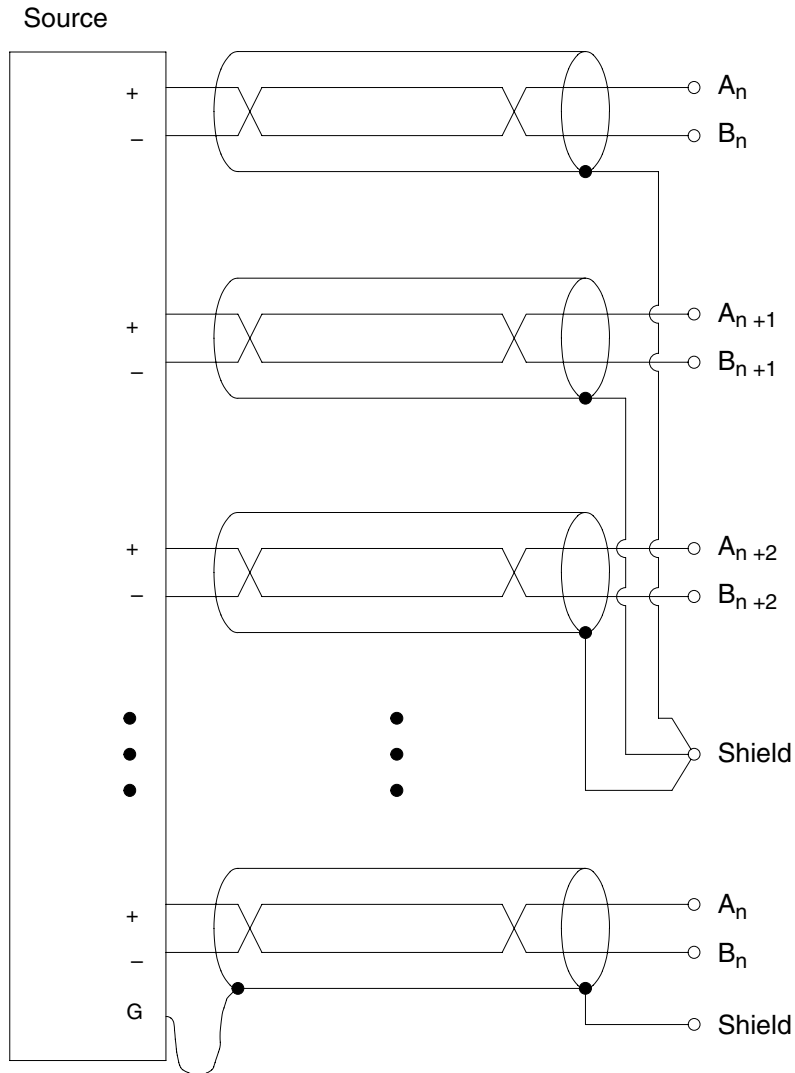

Note Only one ground should be connected at the source when multiple points are connected to the Unit.

Precautions

Observe the following precautions when wiring the Analog Input Unit.

- Use shielded twisted-pair cables for signals lines.
- Keep all cables as short as possible.
- Analog signal cables contain positive and negative lines. Do not reverse the polarity when wiring the inputs.
- Never wire low-voltage cables (such as analog input cables) near high-voltage cables.
- Use wiring ducts for all cables and place signal cables and power cables in separate ducts.
- Do not bend the cables past their natural bending radius.
- Do not wire cables in places subject to vibration.
- Short the positive and negative terminals on all unused inputs to reduce external interference. If the terminals are not shorted, an out-of-range error may occur, causing the ERROR indicator to light.

5-4 Data Exchange with CPU Unit

5-4-1 Communications with the CPU Unit

The Unit communicates with the CPU Unit in 2-word mode using the I/O READ/WRITE instructions in ladder logic. Specific ladder logic examples are in 5-7 *Programming Examples*. Details about the ladder instructions and their execution can be found in the *Operation Manual* for your PC.

The Unit has internal memory that provides storage for the Unit data and configuration parameters. This map contains both read and write areas, and is accessed by the CPU Unit through the I/O READ/WRITE ladder instructions.

The Unit is allocated two I/O words. The first word, referred to as "n" in this manual, is used to output (write) data from the CPU Unit to the Analog I/O Unit. The second word, n + 1, is used to input (read) data from the Analog I/O Unit to the CPU Unit. The following diagram illustrates the basic data movements.

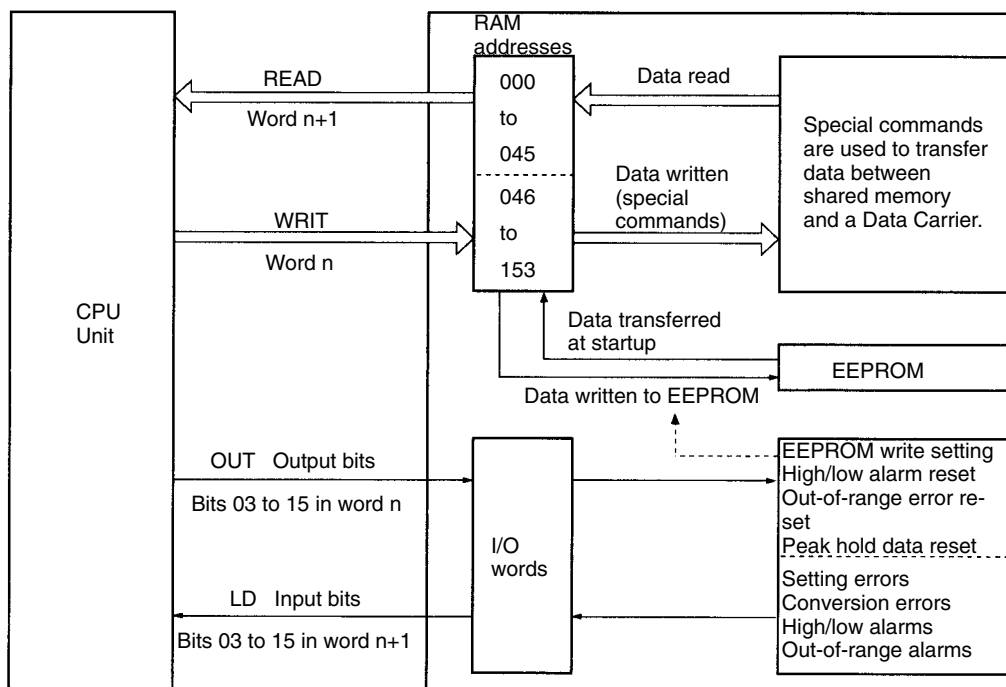

Note The C500-AD501 requires the I/O READ and I/O WRITE instructions to operate. It therefore cannot be mounted to a SYSMAC BUS Slave Rack.

Internal Processing and Parameter Settings

The C500-AD501 contains a processor that converts analog data and performs advanced functions on the data. The following processing is performed.

1, 2, 3...

1. RAM is initialized and internal diagnosis is performed with power is turned ON.
2. Parameters are transferred from EEPROM to RAM. From this point on, the Unit will operate using the parameters in RAM unless they are changed, e.g., by executing the I/O WRITE instruction.

Note EEPROM contains the default settings for parameters when the Unit is shipped from the factory.

3. The I/O WRITE instruction can be executed to change the parameters in RAM. The parameters in EEPROM, however, will not be changed and any changes to the RAM parameters will be lost the next time power is turned OFF.
4. The parameters in RAM at any time can be written to EEPROM by using the EEPROM Write Bit. Refer to 5-6-7 *EEPROM Functions*. The data written to EEPROM will not be lost even if power is turned OFF.
5. RAM contains addresses 000 to 153. Addresses 000 to 045 are read-only and are used to monitor operation. Addresses 046 to 153 are used to set up or execute the various functions.

The I/O READ instruction can be used for all RAM addresses 000 to 153. The I/O WRITE instruction, however, can be used only for RAM addresses 0046 to 153.

Note however, that the number of addresses that can be read or written with the I/O READ/WRITE instructions in one operation is limited to 127. Therefore, in order to read addresses 000 to 153 using the I/O READ instruction, it is necessary to execute I/O READ twice. (Execute the I/O READ instruction twice using the I/O WRITE instruction to set the beginning address that is read.)

6. Input data is converted every 25 ms for all of the enabled input points. (Of the 16 input points, enable only the ones that are actually used.)

Note Using the advanced function can increase the conversion time to greater than 25 ms.

7. The I/O READ and I/O WRITE instructions are used as shown below. Refer to the *Operation Manual* for your PC for details on programming.

I/O READ Instruction – READ

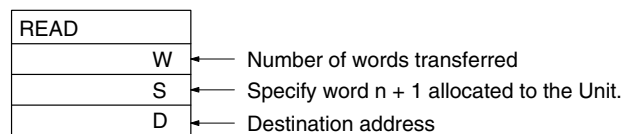

I/O WRITE Instruction – WRIT

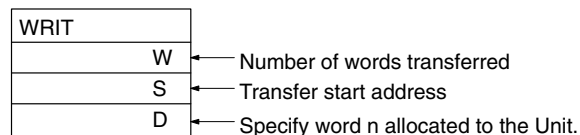

The function codes for the I/O READ and I/O WRITE instructions, READ and WRIT, differ according to the PC, as shown in the table below.

Instruction	Mnemonic	Function code	
		C500/C1000H/C2000H	CVM1/CV
I/O READ instruction	READ	88	190
I/O WRITE instruction	WRIT	87	191

The completion of execution of the I/O READ and I/O WRITE instructions can be determined by checking the status of the Equals Flag. The Equals Flag will be ON when execution has been completed.

Flag	C500	C1000H/C2000H	CVM1/CV
Equals Flag	SR 6306	SR 25506	A50006

READ/WRIT Execution Restrictions

- 1, 2, 3...**
1. The differentiated versions of the READ and WRIT instructions cannot be executed for Special I/O Units on SYSMAC BUS/2 Slave Racks. The READ and WRIT instructions must be executed until the = Flag (A50006) turns ON indicating that the execution is completed.
 2. The READ and WRIT instructions cannot be simultaneously executed for the same Special I/O Unit. In such cases, execute WRIT first, and after the execution is completed, execute READ.
 3. One SYSMAC BUS/2 Remote I/O Master Unit can simultaneously handle up to two READ and WRIT instructions. If two READ and WRIT instructions are executed for Units mounted to SYSMAC BUS/2 Slave Racks and an attempt is made to execute a READ or WRIT instruction for a third Unit, the CY Flag (A50004) will be turned ON without executing the third instruction.
 4. Therefore, when continuously executing READ instructions, you can use the READ and WRIT instructions for a maximum of two Special I/O Units under each SYSMAC BUS/2 Remote I/O Master Unit.
 5. Up to four SYSMAC BUS/2 Remote I/O Master Units can be mounted to the CV1000 or CV2000. In this case, therefore, up to eight READ and WRIT instructions can be executed simultaneously.
 6. Up to 255 words can be transferred using a READ or WRIT instruction.

If the program writes output data after parameters, design the program as follows: Even if an attempt is made to write output data immediately after parameters, such as scaling upper and lower limits, upper and lower limits, and binary/BCD mode settings, are written, the data may not be correctly written due to the internal processing of the Analog Output Unit. For this reason, design the program so that it writes output data at least 100 ms after parameters have been written. Also, the Parameter Update Bit must be turned ON to make the written parameters valid.

5-4-2 IR/CIO Bit Allocations

The Analog Input Unit communicates to the CPU Unit using two-word mode addressing. The I/O READ and I/O WRITE ladder instructions are used to read/write data between the Analog Input Unit and the CPU Unit. The Unit requires two words in the I/O table, one output word from the CPU Unit to the Analog Input Unit, and one input word from the Analog Input Unit to the CPU Unit. The functions of these words are described in the following tables.

Output Word

Direction	Bit	Name	Description
n: From CPU Unit to Analog I/O Unit	0	PC Busy	These bits operate automatically when executing I/O READ/WRITE instructions. It is not possible for the user to write to these bits. Set to 0 when outputting word n using an output instruction, such as the MOV instruction.
	1	PC Write Complete	
	2	PC Read Complete	
	3	EEPROM write bit	Turn ON this bit to cause the Unit to write the current RAM configuration to EEPROM memory in the Unit. On power up, the new parameters will be the default start up parameters.
	4	Serial port write enable bit	This bit enables/disables the serial port on the Unit for writing to the Unit memory map.
	5	High/low alarm reset bit	Turns OFF bit 5 of word n+1, the High/Low Alarm Flag.
	6	Out-of-range error reset bit	Turns OFF bit 6 of word n+1, the Out-of-range Flag.
	7	Peak hold reset bank select bit	Selects which bank of peak hold registers to reset. When this bit is OFF, bits 8 to 15 correspond to input points 1 through 8. When this bit is ON, bits 8 to 15 correspond to input points 9 to 16.
	8	Peak hold register 1/9 reset bit	These bits reset the peak hold registers in the Unit memory map for the input points specified.
	9	Peak hold register 2/10 reset bit	
	10	Peak hold register 3/11 reset bit	
	11	Peak hold register 4/12 reset bit	
	12	Peak hold register 5/13 reset bit	
	13	Peak hold register 6/14 reset bit	
	14	Peak hold register 7/15 reset bit	
15	Peak hold register 8/16 reset bit		

Input Word

Direction	Bit	Name	Description
n+1: From Analog I/O Unit to CPU Unit	0	A/D Busy	These bits operate automatically when executing I/O READ/WRITE instructions.
	1	A/D Read Complete	
	2	A/D Write Complete	
	3	Unconfirmed data error flag	This flag is turned ON when invalid data is received from the serial port or an I/O WRITE instruction. The flag is turned OFF when valid data is sent to the Unit.
	4	Conversion error flag	This flag is turned ON if the Unit detects an internal conversion or calculation error.
	5	High/low alarm error flag	This flag is turned ON when a high/low alarm occurs for any input point.
	6	Out-of-range error flag	This flag is turned ON when an out-of-range range error occurs for any input point.
	7	Unit good flag	This flag oscillates at a rate of 1 Hz when the Unit is operating correctly, 0.5 s ON, 0.5 s OFF.
	8	Peak hold reset 1/9 acknowledged flag	These flags acknowledge that the peak hold registers have been reset by the Unit.
	9	Peak hold reset 2/10 acknowledged flag	
	10	Peak hold reset 3/11 acknowledged flag	
	11	Peak hold reset 4/12 acknowledged flag	
	12	Peak hold reset 5/13 acknowledged flag	
	13	Peak hold reset 6/14 acknowledged flag	
	14	Peak hold reset 7/15 acknowledged flag	
15	Peak hold reset 8/16 acknowledged flag		

5-5 Memory Map

The C500-AD501 has internal RAM for storage of operating parameters during execution. Internal EEPROM memory provides non-volatile storage for these parameters without the need for batteries. Both memory areas have a Unit memory map which defines the operating parameters for the Unit. This Unit memory map is uploaded from EEPROM on power up and used by the Unit during operation. The EEPROM default parameters may be customized and changed by the user to meet the application requirements.

The Unit memory map has read/write and read-only areas. These are marked in the Unit memory map below. The functional description of each memory location is described also.

The table below is an outline of the complete Unit memory map. The detailed functional description of each location and default values are also provided.

Word	Indicates a memory location in the CPU Unit data memory or in the Unit memory map. A word can contain a single piece of data or it can contain bits or flags for each of 16 input points (see format below).
Bit	Turned ON by the user to enable a particular function. 0 = OFF/DISABLE, 1 = ON/ENABLE
Flag	Turned ON by the Unit to indicate status of a Unit function. 0 = OFF/DISABLE, 1 = ON/ENABLE

Both bits and flags are arranged in the following format and correspond to the input points indicated below.

Bit (MSB)	15	14	13	12	11	10	9	8	7	6	5	4	3	2	1	0	(LSB)
Input point	16	15	14	13	12	11	10	9	8	7	6	5	4	3	2	1	

Data in the Unit memory map can be formatted in either signed BCD or 2's Complement Binary. All values for a specific input point must be in the same format. Some values are entered in unsigned BCD. Refer to 5-5-2 *Overview* for valid data ranges for all Unit memory map locations.

Format type	Decimal range	Memory map format
Signed BCD	-7999	F999 (Bit 15 is the sign bit)
	7999	7999
2's Complement Binary	-32767	8001
	-1	FFFF
	0	0000
	32767	7FFF

5-5-1 Error Flags

There are a number of memory map error flags in the Unit which can be used to verify status and operation. These flags are listed in the following table.

Flag type	Function
High and low alarm flags	Indicate the input signal is outside the alarm limits specified in the Unit memory map
Over and under range errors	Indicate the input signal is outside the specified range selected by the DIP switches
Unconfirmed data error flags	Indicate a data conversion error in the Unit
EEPROM error flags	Indicate errors with the EEPROM write function and write cycle counts

5-5-2 Overview

The following table outlines the contents of the memory map. Refer to the next section for details.

Contents	Memory map word	Read/write	Data format	Valid data range	Factory default	Save/load EEPROM	Reset on input point enable	Reset on function enable	Conditions
Alarm flags	00	R	Binary	0 or 1	0	No	No	No	Set by Unit. Reset by user using I/O word n.
Conversion data	01 to 16	R	Binary BCD	-32768 to 32767 -7999 to 7999	0 0	No	Yes	Yes	Set by Unit.
High/low alarm flags	17 to 21	R	Binary	0 or 1	0	No	No	No	Set by Unit.
Peak hold data	22 to 37	R	Binary BCD	-32768 to 32767 -7999 to 7999	0 0	No	Yes	Yes	Set by Unit.
Input point active flags	38	R	Binary	0 or 1	All 1	No	Yes	No	Set by Unit.
Function active flags	39 to 45	R	Binary	0 or 1	0	No	No	Yes	Set by Unit.
Pointer word	46	R/W	BCD	00 to 153	0	No	No	No	Set by user.
Input point enable bits	47	R/W	Binary	0 or 1	All 1	Yes	No	No	Set by user.
BCD/binary select bits	48	R/W	Binary	0 or 1	All 1 (BCD)	Yes	No	No	Set by user.
Function enable bits	49 to 54	R/W	Binary	0 or 1	0	Yes	No	No	Set by user.
High/low alarm limits	55 to 86	R/W	Binary BCD	-32768 to 32767 -7999 to 7999	— —	Yes	No	No	Set by user.
Filter constants	87 to 102	R/W	Binary BCD	1 to 32767 1 to 7999	100	Yes	No	No	Set by user.
Averaging sample count	103 to 118	R/W	Binary BCD	1 to 32767 1 to 7999	100	Yes	No	No	Set by user.
Scaling limits	119 to 150	R/W	Binary BCD	-32768 to 32767 -7999 to 7999	— —	Yes	No	No	Set by user.
EEPROM write count	151	R	Binary	0000 to 9999	0	Yes	No	No	Set by Unit.
EEPROM error flags	152	R	Binary	0 or 1	0	No	No	No	Set by Unit.
EEPROM compare word	153	W	Binary	0000 to 9999	0	No	No	No	Set by user.

5-5-3 Memory Map Details

Read/write	Memory map word	Bits	Input point	Function	Description
R	00	00 to 15	1 to 16	Alarm flags	These flags are turned ON by the Unit when a low or high alarm condition occurs (word 17 and 18). They are turned OFF when individual alarms are reset in words 17 and 18.
R	01 02 03 04 05 06 07 08 09 10 11 12 13 14 15 16	00 to 15	1 2 3 4 5 6 7 8 9 10 11 12 13 14 15 16	Converted data	These words contain the last A/D conversion values for each input point. The data format is selected by word 48 for each input point. The default format is BCD. If advanced functions such as scaling, filtering, and averaging are enabled, they are performed on the data before it is entered into these locations.
R	17	00 to 15	1 to 16	High alarm flags	These flags are turned ON by the Unit when a high alarm condition occurs for each input point. These bits are turned OFF by bit 05 of I/O word n for the Unit.
R	18	00 to 15	1 to 16	Low alarm flags	These flags are turned ON by the Unit when a low alarm condition occurs for each input point. These bits are turned OFF by bit 05 of I/O word n for the Unit.
R	19	00 to 15	1 to 16	Over range flags	These flags are turned ON by the Unit when an over range condition occurs for each input point. The Unit detects a voltage higher than the range setting of the DIP switches for each input. The Unit will turn these bits ON and OFF based on the input signal level. The Unit also turns ON bit 06 of I/O word n+1 when this error occurs. These alarms are always active.
R	20	00 to 15	1 to 16	Under range flags	These flags are turned ON by the Unit when an under range condition occurs for each input point. The Unit detects a voltage lower than the range setting of the DIP switches for each input. The Unit will turn these bits ON and OFF based on the input signal level. The Unit also turns ON bit 06 of I/O word n+1 when this error occurs. These alarms are always active.

Read/write	Memory map word	Bits	Input point	Function	Description
R	21	00 to 15	1 to 16	Unconfirmed data error flags	These flags are turned ON by the Unit when invalid configuration data is written to the Unit memory map for an input point. The bits are cleared when valid data is written to the Unit memory map. The Unit also turns ON bit 3 of I/O word n+1 when this error occurs.
R	22 23 24 25 26 27 28 29 30 31 32 33 34 35 36 37	00 to 15	1 2 3 4 5 6 7 8 9 10 11 12 13 14 15 16	Peak hold data	These words contain the latest peak hold values for each input point. The data format is determined by word 48. The Unit performs scaling, filtering, and averaging functions if selected before placing peak hold values in these words. The peak hold function is enabled/disabled for each input point by turning ON bits in word 52. These words are reset by I/O word n, bits 07 through 15. The Unit acknowledges the reset in I/O word n+1 bits 08 to 15. See 5-6-5 Peak Hold for details.
R	38	00 to 15	1 to 16	Input point active flags	These flags are turned ON by the Unit indicating the enable/disable status of each input point that is set in word 47.
R	39	00 to 15	1 to 16	BCD/binary select flags	These flags are turned ON by the Unit indicating the data format selected for each input point in word 48.
R	40	00 to 15	1 to 16	Scaling active flags	These flags are turned ON by the Unit indicating the enable/disable status of the scaling function for each input point set in word 49.
R	41	00 to 15	1 to 16	Averaging active flags	These flags are turned ON by the Unit indicating the enable/disable status of the averaging function for each input point set in word 50.
R	42	00 to 15	1 to 16	Filtering active flags	These flags are turned ON by the Unit indicating the enable/disable status of the filtering function for each input point set in word 51.
R	43	00 to 15	1 to 16	Peak hold active flags	These flags are turned ON by the Unit indicating the enable/disable status of the peak hold function for each input point set in word 52.
R	44	00 to 15	1 to 16	Low alarm active flags	These flags are turned ON by the Unit indicating the enable/disable status of the low alarm function for each input point set in word 53.
R	45	00 to 15	1 to 16	High alarm active flags	These flags are turned ON by the Unit indicating the enable/disable status of the high alarm function for each input point set in word 54.

Read/write	Memory map word	Bits	Input point	Function	Description
R/W	46	00 to 15	---	Pointer word	The pointer word is used to set the starting location in the Unit memory map for the I/O READ and I/O WRITE instructions that are executed in ladder logic in the CPU Unit. This allows the user to selectively read and write parts of the Unit memory map.
R/W	47	00 to 15	1 to 16	Input point enable bits	These bits are turned ON by the user to enable/disable each input point. The Unit scans only input points that are enabled. The default value is all input points enabled.
R/W	48	00 to 15	1 to 16	BCD/binary select bits	These bits are turned ON or OFF by the user to select the data format used by each input point. ON: BCD OFF: Binary This selection specifies the format of the conversion data in words 01 to 16. BCD and binary can be used at the same time for different input points. NOTE: When specifying a data format for an input point, all Unit memory map words for that specific input point should have the same format. Mixing formats for an input point will cause erroneous results to be reported. The default value is BCD (ON) for all input points.
R/W	49	00 to 15	1 to 16	Scaling enable bits	These bits are turned ON by the user to enable/disable the scaling function for each input point. The default value is disabled (OFF) for all input points.
R/W	50	00 to 15	1 to 16	Averaging enable bits	These bits are turned ON by the user to enable/disable the Averaging function for each input point. The default value is disabled (OFF) for all input points.
R/W	51	00 to 15	1 to 16	Filtering enable bits	These bits are turned ON by the user to enable/disable the filtering function for each input point. The default value is disabled (OFF) for all input points.
R/W	52	00 to 15	1 to 16	Peak hold enable bits	These bits are turned ON by the user to enable/disable the peak hold function for each input point. The default value is disabled (OFF) for all input points.
R/W	53	00 to 15	1 to 16	Low alarm enable bits	These bits are turned ON by the user to enable/disable the low alarm function for each input point. The default value is disabled (OFF) for all input points.

Read/write	Memory map word	Bits	Input point	Function	Description
R/W	54	00 to 15	1 to 16	High alarm enable bits	These bits are turned ON by the user to enable/disable the high alarm function for each input point. The default value is disabled (OFF) for all input points.
R/W	55 56 57 58 59 60 61 62 63 64 65 66 67 68 69 70 71 72 73 74 75 76 77 78 79 80 81 82 83 84 85 86	00 to 15	1 1 2 2 3 3 4 4 5 5 6 6 7 7 8 8 9 9 10 10 11 11 12 12 13 13 14 14 15 15 16 16	Low alarm limit High alarm limit Low alarm limit High alarm limit Low alarm limit High alarm limit Low alarm limit High alarm limit Low alarm limit High alarm limit Low alarm limit High alarm limit Low alarm limit High alarm limit Low alarm limit High alarm limit Low alarm limit High alarm limit Low alarm limit High alarm limit Low alarm limit High alarm limit Low alarm limit High alarm limit Low alarm limit High alarm limit Low alarm limit High alarm limit Low alarm limit High alarm limit	These words contain the low and high alarm limits for each input point. The format of these values should match the data format selected for each input point in word 48. Valid values are XXXX to XXXX binary and -7999 to 7999 BCD. Alarm limits must be specified in scaled units if the scaling function is enabled for the input point. The default values are 0100 for the low limit and 3900 for the high limit.
R/W	87 88 89 90 91 92 93 94 95 96 97 98 99 100 101 102	00 to 15	1 2 3 4 5 6 7 8 9 10 11 12 13 14 15 16	Filter constants	These words contain the filtering time constants for each input point. The values are in milliseconds. Valid values are BCD 0001 to 9999 and binary 0001 to 7FFF. The default value is 0100 BCD. The filtering function is performed prior to the data being placed in the conversion data words (01 through 16).

Read/write	Memory map word	Bits	Input point	Function	Description
R/W	103 104 105 106 107 108 109 110 111 112 113 114 115 116 117 118	00 to 15	1 2 3 4 5 6 7 8 9 10 11 12 13 14 15 16	Averaging sample count	These words contain the number of Unit conversions to average before reporting conversion data to words 01 to 16. The values are in number of samples. Valid values are BCD 0001 to 9999 and binary 0001 to 7FFF. The default value is 0020 BCD. The averaging function is performed prior to the data being placed in the conversion data words (01 through 16).
R/W	119 120 121 122 123 124 125 126 127 128 129 130 131 132 133 134 135 136 137 138 139 140 141 142 143 144 145 146 147 148 149 150	00 to 15	1 1 2 2 3 3 4 4 4 5 5 6 6 7 7 8 8 9 9 10 10 11 11 12 12 13 13 14 14 15 15 16 16	Scaling low limit Scaling high limit Scaling low limit Scaling high limit Scaling low limit Scaling high limit Scaling low limit Scaling high limit Scaling low limit Scaling high limit Scaling low limit Scaling high limit Scaling low limit Scaling high limit Scaling low limit Scaling high limit Scaling low limit Scaling high limit Scaling low limit Scaling high limit Scaling low limit Scaling high limit Scaling low limit Scaling high limit Scaling low limit Scaling high limit Scaling low limit Scaling high limit Scaling low limit Scaling high limit Scaling low limit Scaling high limit	These words contain the scaling low and high limits for each input point. The values are in engineering units. The default values are 0000 for the low limit and 4095 for the high limit. The scaling function is performed prior to the data being placed in the conversion data words (0 to 16).
R	151	00 to 15	---	EEPROM write count	This word contains the current number of write operations that have been executed for the EEPROM.
R	152	00 to 06	---	EEPROM error flags	This word contains error flags used during the EEPROM write operation.
R/W	153	00 to 15	---	EEPROM compare word	This word is set by the user to confirm that an EEPROM write operation should occur. This is a safety to prevent erroneous writes from occurring and damaging the EEPROM chip.

5-5-4 Using the Unit Memory Map Configuration Sheet

To assist in the custom configuration of the Unit, a Configuration Worksheet has been provided in *Appendix A*. Values for all advanced functions can be entered in the worksheet. These values can then be easily transferred to data memory for use by the Unit.

5-6 Functions

5-6-1 Overview

The C500-AD501 is microprocessor based and can perform a number of functions on the converted data before putting it in the Unit memory map where it can be read by the CPU Unit. The following pages describe the operation of these functions and how to enable the functions. The specific Unit memory map locations, valid values, and functions are described in *5-5 Memory Map in Analog Input Unit*.

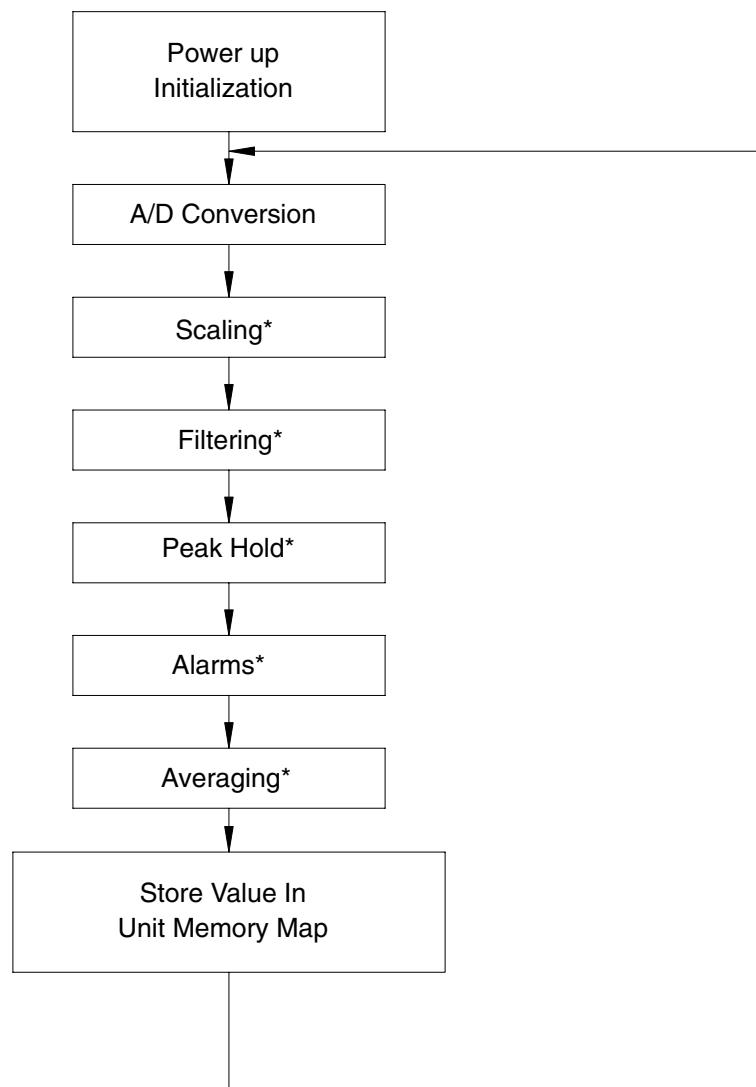

Note When configuring the Unit's functions, use the following steps:

- 1, 2, 3... 1. Disable the input point to be configured in Unit memory map word 47.
2. Reconfigure the input point for the desired function.
3. Enable the input point in Unit memory map word 47.

Averaging and Alarms

High and low limit alarms are processed before averaging is performed. It is thus possible that the averaged input data will still be within the set limits even when a high or low alarm has been given. This can happen when the upper or lower limit has been exceeded only momentarily, causing the High or Low Alarm Flag to turn ON even though the average value has not yet (and possibly never will) exceeded the limits.

5-6-2 Scaling

The scaling function can be used to perform conversion of data to engineering units prior to transfer to the CPU Unit. With this feature enabled, the Unit maps the 0 to 4095 range of the analog input to a new user-specified range. The range can have upper and lower limits anywhere in the range -32768 to 32767 (binary) or -7999 to 7999 (BCD). Scaling can even be used to accomplish a sign inversion by setting the lower scale value positive and the upper scale value negative. Examples 1, 2, and 3, illustrate scaling:

Example 1: Scaling 0 to 10 Volts to Engineering Units (0 to 5,000 l/min)

Input point 1 of the Unit is connected to a 0 to 10 V signal from a flow sensor in a pipe. It has been determined that a 0 V reading on the sensor indicates no flow in the pipe and a 10 V reading on the sensor indicates 5,000 liters/minute.

To configure the Unit to report the data in percentage full:

- 1, 2, 3...**
1. Set the scaling low and high limits to 0 and 5000.
 2. Turn ON the scaling enable bit for input point 1.

Input Range: 0 to 10 V
 Scaling High: 5000 liters/minute
 Scaling Low: 0 liters/minute

BCD

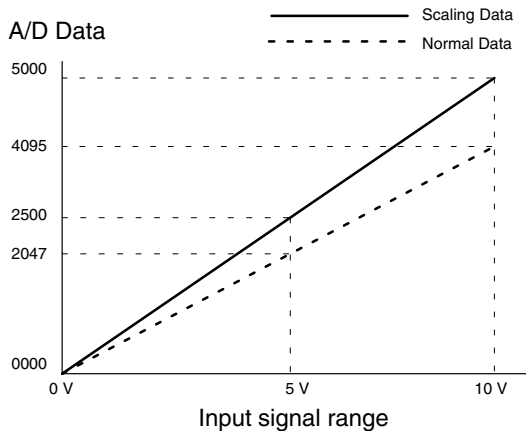

Binary (Hex)

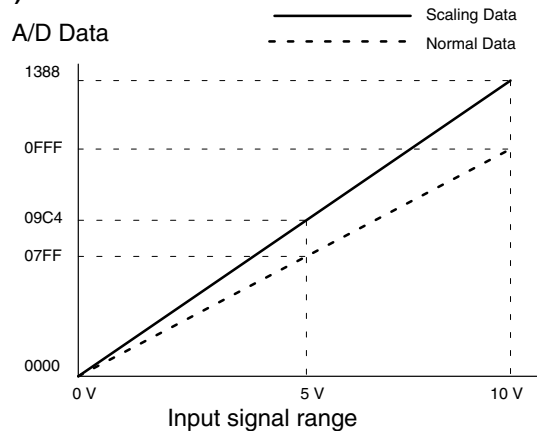

Example 2: Scaling 0 to 5 V to Percent Full

Input point 6 of the Unit is connected to a 0 to 5 V signal from a level sensor in a tank. The user is not interested in the actual volume of liquid in the tank, but rather in the percent full reading for the tank. It has been determined that a 0 V reading on the sensor indicates the tank is 25% full, and a 5 V reading on the sensor indicates the tank is 100% full.

To configure the Unit to report the data in percentage full:

- 1, 2, 3...**
1. Set the scaling low and high limits to 25 and 100.
 2. Turn ON the scaling enable bit for input point 6.

Input Range: 0 to 5V
 Scaling High: 100%
 Scaling Low: 25%

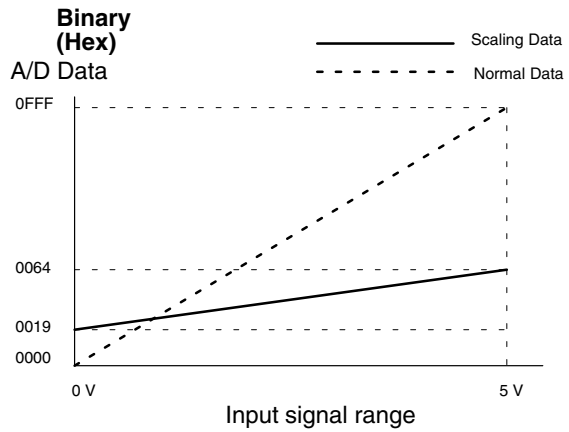
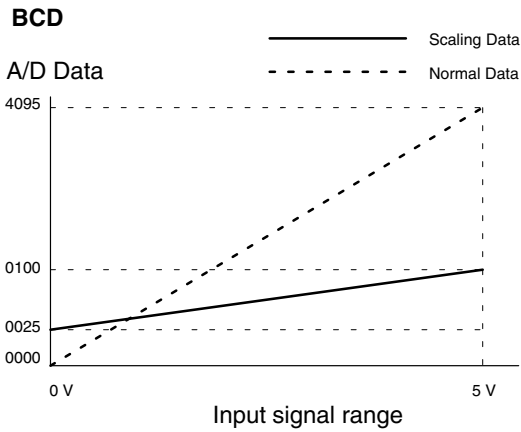

Example 3: Scaling 4 to 20 mA to 300 to 1,200 PSI

Input point 12 of the Unit is connected to a 4 to 20 mA signal from a pressure sensor in pipe. The range for input point 12 has been set to 0 to 20 mA. It has been determined that a 4 mA reading on the sensor indicates a pressure of 300 psi, and a 20 mA reading on the sensor indicates a pressure of 1200 psi. Thus the range of the sensor is (900 psi)/(16 mA), or 56.25 psi/mA. If the sensor could report a reading of 0 mA, the pressure would be 300 – (56.25 × 4), or 75 psi. To configure the Unit to report the data in percentage full:

- 1, 2, 3...**
1. Set the scaling low and high limits to 75 and 1200.
 2. Turn ON the scaling enable bit for input point 12.

Input Range: 0 to 20mA
 Scaling High: 1,200 PSI
 Scaling Low: 75 PSI

BCD

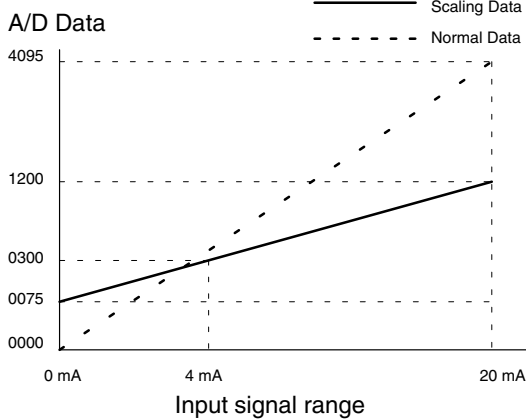

Binary (Hex)

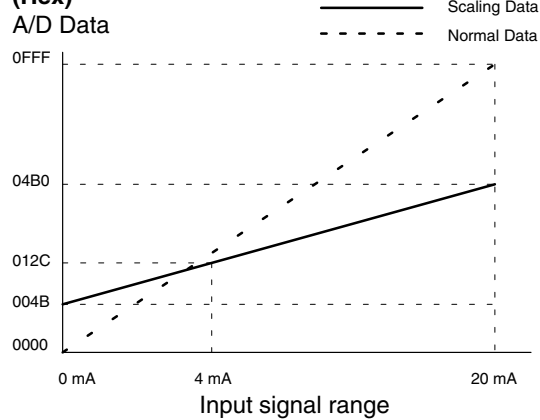

Unit memory map location	Description	Valid data
40	Scaling active flags	0 or 1
49	Scaling enable bits	0 or 1
119 to 150	Scaling low and high limits	BCD or 2's Complement Binary

To use the scaling function for each input point do the following:

- 1, 2, 3...**
1. Set the input point scaling low and input point scaling high values for each input point.
 2. Turn ON the scaling enable/disable bit for the input point.

5-6-3 Averaging

The averaging function can be used to perform averaging of many samples of data prior to reporting the value to the CPU Unit. This function is useful for reducing or eliminating noise commonly found in analog input signals. When averaging is enabled for a particular input point, the Unit takes the requested number of input samples for that input point and computes an average before reporting data to the CPU Unit. The average is the algebraic sum of all of the conversions for the user-specified count divided by the sample count value. Averaging uses a sequential method as shown below.

$$\text{1st Reported Value} = \frac{\text{Conv}_1 + \text{Conv}_2 + \dots + \text{Conv}_n}{n}$$

$$\text{2nd Reported Value} = \frac{\text{Conv}_{n+1} + \text{Conv}_{n+2} + \dots + \text{Conv}_{n+n}}{n}$$

n = number of sample counts, in BCD, specified by the user (minimum of 1, maximum of 9999)

Unit memory map location	Description	Valid data
41	Averaging active flags	0 or 1
50	Averaging enable bits	0 or 1
103 to 118	Averaging sample counts	BCD: 0001 to 9999 Binary: 0001 to 7FFF

To use this function for each input point do the following:

- 1, 2, 3...**
1. Set the input point averaging sample counts value for each input point.
 2. Turn ON the averaging enable bit for each input point.

5-6-4 Filtering

The filtering function is used to filter samples of data prior to reporting the value to the CPU Unit. The filtering option is similar in function to the averaging function. While the averaging function is based on a quantity of counts to reach the data, the filtering function is based on a time. The filtering function is useful for eliminating aberrations in the data due to noise or stray induced signals.

Unit memory map location	Description	Valid data
42	Filtering active flags	0 or 1
51	Filtering enable bits	0 or 1
87 to 102	Filtering constants	BCD: 0001 to 9999 Binary: 0001 to 7FFF

To use this function for each input point do the following:

1. Set the input point filtering time constant value for each input point.
2. Turn ON the filtering enable bit for each input point.



Caution

When performing filtering, it is recommended that the ladder program perform READ instructions only. Performing WRIT during filtering may cause long filtering delays due to the constant recalculation of the Unit operating parameters.

5-6-5 Peak Hold

The peak hold function can be used to detect peak conversion values of rapidly changing analog input signals. These values are stored in separate memory locations in the Unit memory map. This data is reset each time the peak hold function is enabled for the input point. There are also Reset Bits and Acknowledge Flags for the peak hold registers. Refer to pages 78 and 79 for details

Unit memory map location	Description	Valid data
22 to 37	Peak hold data	BCD: -7999 to 7999 Binary: -32767 to 32767
43	Peak hold active flags	0 or 1
52	Peak hold enable bits	0 or 1

To use this function for each input point, turn ON the input point peak hold enable bit for each input point.

Note The peak hold function retains invalid values when changing from binary to BCD. Therefore, the peak hold enable bit should be re-enabled after changing data formats.

5-6-6 High/Low Alarms

The alarm function can be used to perform a comparison of the input point conversion data to specific low and high limits that are stored in the Unit memory map. The Unit turns ON the alarm flags in the Unit memory map when the input point conversion data is outside the specified limits. The Unit can produce low alarms, high alarms, or both.

Once turned ON, the High and Low Alarm Flags will remain ON even if the input data returns to within the set limits. Turn ON the High and Low Alarm Reset Bits to turn OFF the Alarm Flags.

Unit memory map location	Description	Valid data
00	Alarm flags	0 or 1
17	High alarm flags	0 or 1
18	Low alarm flags	0 or 1
44	Low alarm active flags	0 or 1
45	High alarm active flags	0 or 1
53	Low alarm enable bits	0 or 1
54	High alarm enable bits	0 or 1
55 to 86	Low and high alarm limits	BCD: -7999 to 7999 Binary: -32767 to 32767

To use this function for each input point proceed as follows:

- 1, 2, 3...** 1. Set the input point low alarm limit value and input point high alarm limit value for each input point.
2. Turn ON the input point low alarm enable bit and input point high alarm enable bit for each input point.

5-6-7 EEPROM Functions

The Unit has an internal EEPROM memory which stores the Unit memory map. When power is applied, the Unit uploads the EEPROM to RAM and begins execution using the RAM values in the Unit memory map. There is an EEPROM write function that allows the user to store new default Unit memory map values that will be uploaded on the next power up of the Unit.

Unit memory map location	Description	Valid data
151	EEPROM write count	0000 to 9999
152	EEPROM error flags 1 = 5000 writes to EEPROM 2 = 10000 writes to EEPROM 3 = Write disabled to serial port 4 = Calibration data error 5 = Parameter data error 6 through 15 reserved	0 or 1
153	EEPROM compare word	0000 to 9999

To store the current Unit memory map into EEPROM, do the following.

- 1, 2, 3...**
1. Read Unit memory map location 151.
 2. Set Unit memory map location 153 equal to location 151.
 3. Turn OFF the execution conditions for all READ/WRITE instructions to the Unit.
 4. Turn ON bit 03 in I/O word n. The Unit will write the Unit memory map to EEPROM. The Unit will then increment location 151 by 1. Location 153 must be updated again to enable another write cycle to take place.

- Note**
1. The EEPROM has a life of 10,000 write cycles. When writing to the EEPROM, use caution to avoid continuous write operations by executing the ladder logic only one time or updating the location manually using data memory. The Unit will require a replacement EEPROM at 10,000 write cycles.
 2. During the EEPROM write cycle, the Unit temporarily suspends the cycling of the Unit good flag in I/O word n+1 bit 07. The cycling resumes after the EEPROM has been written.

5-7 User Programming Examples

This section provides some user programming examples for CV-series PCs. These examples may need to be altered for use with other PCs. Refer to the documentation on programming for your PC for details.

5-7-1 Basic Programming

The ladder diagram instruction shown below is used in conjunction with the default settings. It can be executed to read the A/D data and alarm flags for each input point into the data memory (DM) area. This programming rung assumes that the Unit is in its factory default settings.

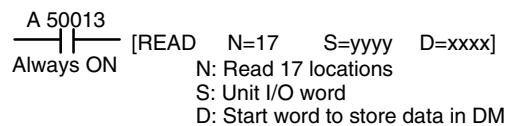

Alarm flags and analog conversion data will be stored in CPU Unit memory beginning at the DM address specified in the ladder diagram instruction.

DM xxxx	Unit alarm flags
DM xxxx + 1 to xxxx + 16	Input conversion data in BCD format, for inputs 1 to 16

READ/WRIT Execution Restrictions

- 1, 2, 3... 1. The differentiated READ and WRIT instructions cannot be executed for Special I/O Units on SYSMAC BUS/2 Slave Racks. The READ and WRIT instructions must be executed until the Equals Flag (A50006) turns ON indicating that the execution is completed.
2. The READ and WRIT instructions cannot be simultaneously executed for the same Special I/O Unit. In such cases, execute WRIT first, and after the execution is completed, execute READ.
3. One SYSMAC BUS/2 Remote I/O Master Unit can simultaneously handle up to two READ and WRIT instructions. If two READ and WRIT instructions are executed for Units mounted to SYSMAC BUS/2 Slave Racks and an attempt is made to execute a READ or WRIT instruction for a third Unit, the Carry Flag (A50004) will be turned ON without executing the third instruction.
4. Therefore, when continuously executing READ instructions, you can use the READ and WRIT instructions for a maximum of two Special I/O Units under each SYSMAC BUS/2 Remote I/O Master Unit.
5. Up to four SYSMAC BUS/2 Remote I/O Master Units can be mounted to the CV1000 or CV2000. In this case, therefore, up to eight READ and WRIT instructions can be executed simultaneously.
6. Up to 255 words can be transferred using a READ or WRIT instruction.

5-7-2 Using the Unit Configuration Worksheet

Appendix A is a worksheet to use when configuring the advanced functions available in the Unit. It is particularly useful in setting up a table in the CPU Unit data memory area that corresponds to the Unit memory map. The data can then be easily transferred to the Unit using the I/O WRITE ladder instruction.

Note When configuring the Unit's advanced functions, use the following steps.

- 1, 2, 3... 1. Disable the input point to be configured in Unit memory map word 47.
2. Reconfigure the input point for the desired advanced function.
3. Enable the input point in Unit memory map word 47.

5-7-3 Using the Pointer Word in the Unit Memory Map

The Unit has an internal memory map for storage of data and configuration parameters. The table is 153 words in length, with both read-only and read/write registers. The pointer word is used to set the beginning memory map location for either the I/O READ or I/O WRITE ladder instructions. This allows the user to access any area of the table directly without reading or writing data that is not required. The result is faster Unit processing, and faster data transfer between the Unit and the CPU Unit. The pointer word is memory map location 46. The format is unsigned BCD. Valid values are 0 to 0153. The default value is 0000. The following sections explain the operation of the pointer word with both the I/O READ and I/O WRITE ladder instructions.

5-7-4 Writing Data to the Unit

This section describes the use of the pointer word with the I/O WRITE ladder instruction. For additional information regarding the I/O WRITE instruction, refer to the *Operation Manual* for your PC.

There are two rules when using the pointer word with the I/O WRITE instruction.

- 1, 2, 3...**
1. If the number of words transferred (specified in the instruction) to the Unit is one, the following processing occurs.
 - The Unit writes the value of this word to the pointer word location in the Unit memory map (46).
 - This value now becomes the first memory location to be read in subsequent I/O READ instructions.
 - The pointer word retains this value unless another 1-word I/O write is executed, or the system power is cycled. If the value has been saved to the EEPROM in the Unit, then it is automatically uploaded on power up.

Example:

Execute a 1-word I/O write to the Unit. The value of the word transferred is 0022. The Unit sees the number of words is 1, and places the value 0022 into memory map location 46.

Execute an I/O READ instruction specifying the number of words to be read as 0016.

The Unit returns 16 words to the CPU Unit, beginning with Unit memory map location 22 through 37.

Note The I/O READ instruction can transfer a maximum of 127 words. The Unit always prepares a table for transfer that is 127 words in length. If the pointer word is set to a value greater than 27 (i.e., 28, $153 - 28 = 125$), and the read request is for 127 words, the Unit transfers words 28 to 153 (125 words) and fills words 126 and 127 with 0000. This is because the pointer word is set to a value and the read is for a number of words that goes beyond the end of the table.

2. If the number of words transferred to the Unit is greater than one, the following processing occurs.
 - The Unit interprets the first word as a temporary pointer value (which does not replace word 46 in the Unit memory map).
 - If the value of first word is 0000, then the Unit updates the memory map beginning at location 47 with the remaining words transferred. This is the first word of the write area in the Unit memory map.
 - If the first word is greater than 0 and less than 47, the Unit turns ON the unconfirmed data error flag because an attempt has been made to write to a read-only area of the Unit memory map. The data sent is ignored.

- If the temporary pointer value is greater than 46, the Unit writes the data following the temporary pointer value into the Unit memory map beginning at the location specified by the temporary pointer value. The temporary pointer value is then discarded.

Example:

Execute a 10-word I/O write to the Unit. The value of the first word transferred is 0047.

The Unit sees the number of words is greater than one, and reads the first word as the temporary pointer value. The Unit then updates its memory map with the remaining nine words beginning at location 47.

- Note**
1. Whenever data is written to the Unit using WRIT, the validity of all the data is checked. If there are any errors in the data, none of the data will be written. It is thus best to write only the required data to reduce the chance of errors. When writing data that includes values for functions not being used, be sure to set the values for unused functions to the defaults in advance.
 2. When executing the WRITE instruction with the First Cycle Flag, there is a possibility that the Analog I/O Unit's internal processing may not be completed, and the WRITE instruction is not executed. When executing the WRITE instruction immediately after operation is started, use either of the following as the execution condition of the WRITE instruction:
 - Bit 2 of word n+1 (A/D Write Completed Flag)
 - A timer of at least 3 s.

Example 1: WRITE Data Memory to the Unit Memory Map

This example show how to write the entire Unit Memory Map Write area (Locations 47 to 150). These are the user configurable locations in the Unit Memory Map that enable the various Unit functions. The Data Memory in the CPU Unit can be set up using the Unit configuration worksheet in Appendix A. The first word is the temporary write pointer.

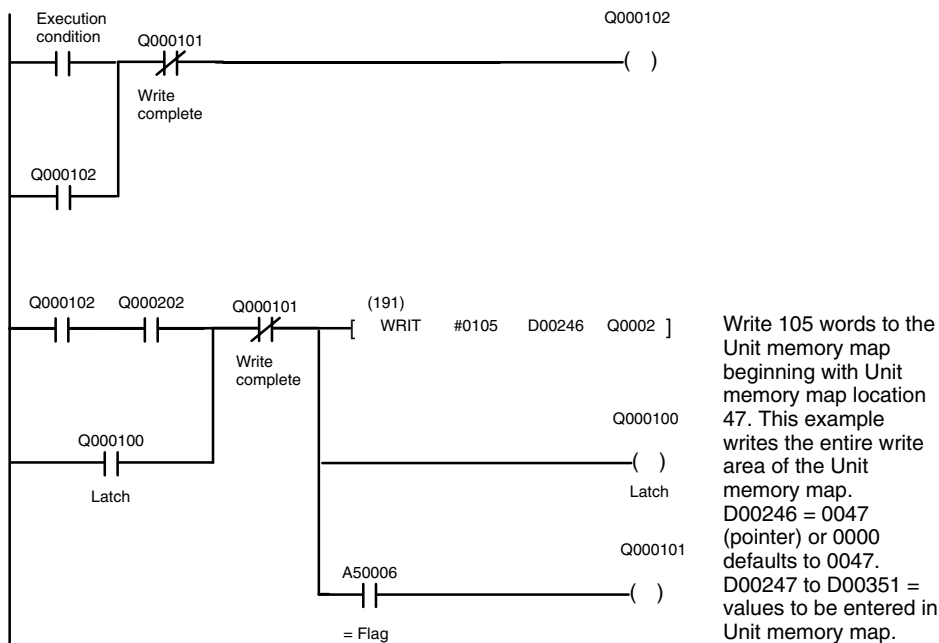

Example 2: WRITE to Selected Locations in the Unit Memory Map

This example shows how to write a specific value to a single Unit Memory Map Location.

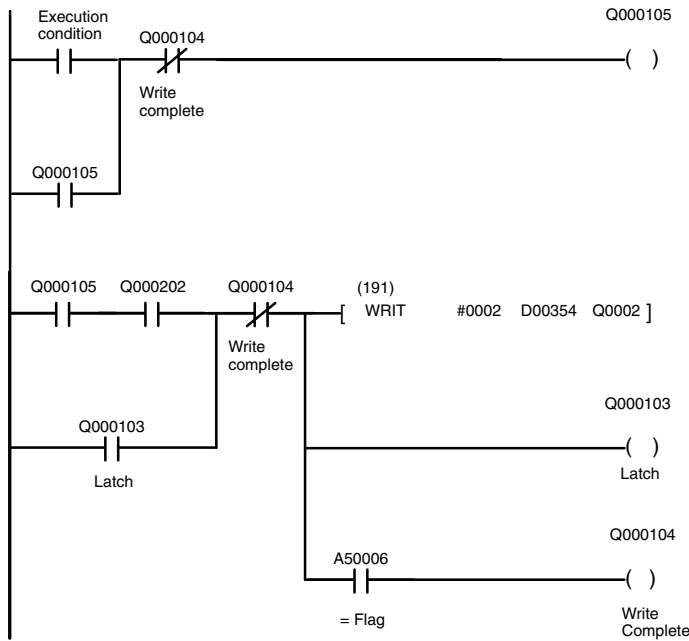

This example writes 1 word to the Unit memory map. D00354 = the Unit memory map location temporary pointer. D00355 = the value to put in the Unit memory map location specified in D00354.

5-7-5 Reading Data from the Unit

I/O READ Instruction (READ) and the Pointer Word Operation

This section describes the use of the pointer word with the I/O READ ladder instruction. For additional information regarding the I/O READ instruction, refer to the *Operation Manual* for your PC.

There are three rules when using the pointer word with the I/O READ instruction.

- 1, 2, 3... 1. The default value of the Pointer word is 0, except when the value has been modified and this modified value saved to the EEPROM in the Unit. On power up, the Unit uploads this value from the EEPROM into RAM prior to execution.
2. When an I/O READ instruction is executed, the Unit reads the value of the pointer word and returns the number of words requested beginning with the location specified by the pointer word in the Unit memory map. The pointer word value can be 0000 to 0153.
3. If the number of words requested extends beyond the end of the table given a value in the pointer word, then the remaining words transferred up to 127 will be filled with zeros (0000).

Example 1: READ Alarm and Conversion Data from the Unit

This example shows how to read the first 46 words from the Unit Memory Map. This data includes the Conversion Data, Alarm Data, and Peak Hold Data.



Example 2: READ the Entire Unit Memory Map into Data Memory

This example shows how to read the entire Unit Memory Map into the Data Memory of the CPU Unit.

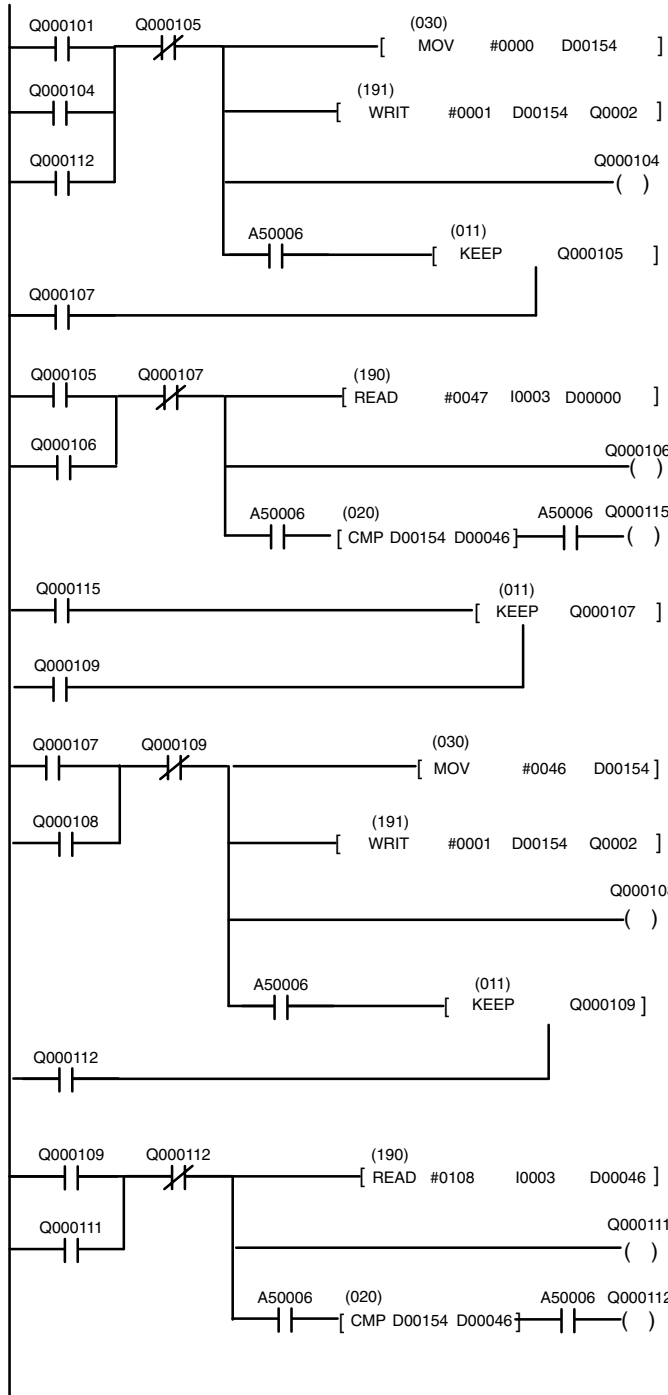

Step 1: Using a 1-word write instruction, set the pointer word to 0.

Step 2: Read the first 47 words from the Unit memory map and store in DM000 to DM0046. Confirm that the pointer was set to 0.

Step 3: Read complete

Step 4: Set pointer with word equal to 0046 using a 1-word write instruction.

Step 5: Read 108 words from the Unit memory map beginning with word 46 and store in DM0046 DM015.

5-7-6 Typical Programming Examples

Examples 1 through 4 are typical ladder diagrams that show the flexible access to the Unit set up and advanced functions.

Example 1: Configuring the Scaling Function

This example shows how to configure the scaling function for specific input points. Refer to 5-6-2 *Scaling* for information on using the scaling function.

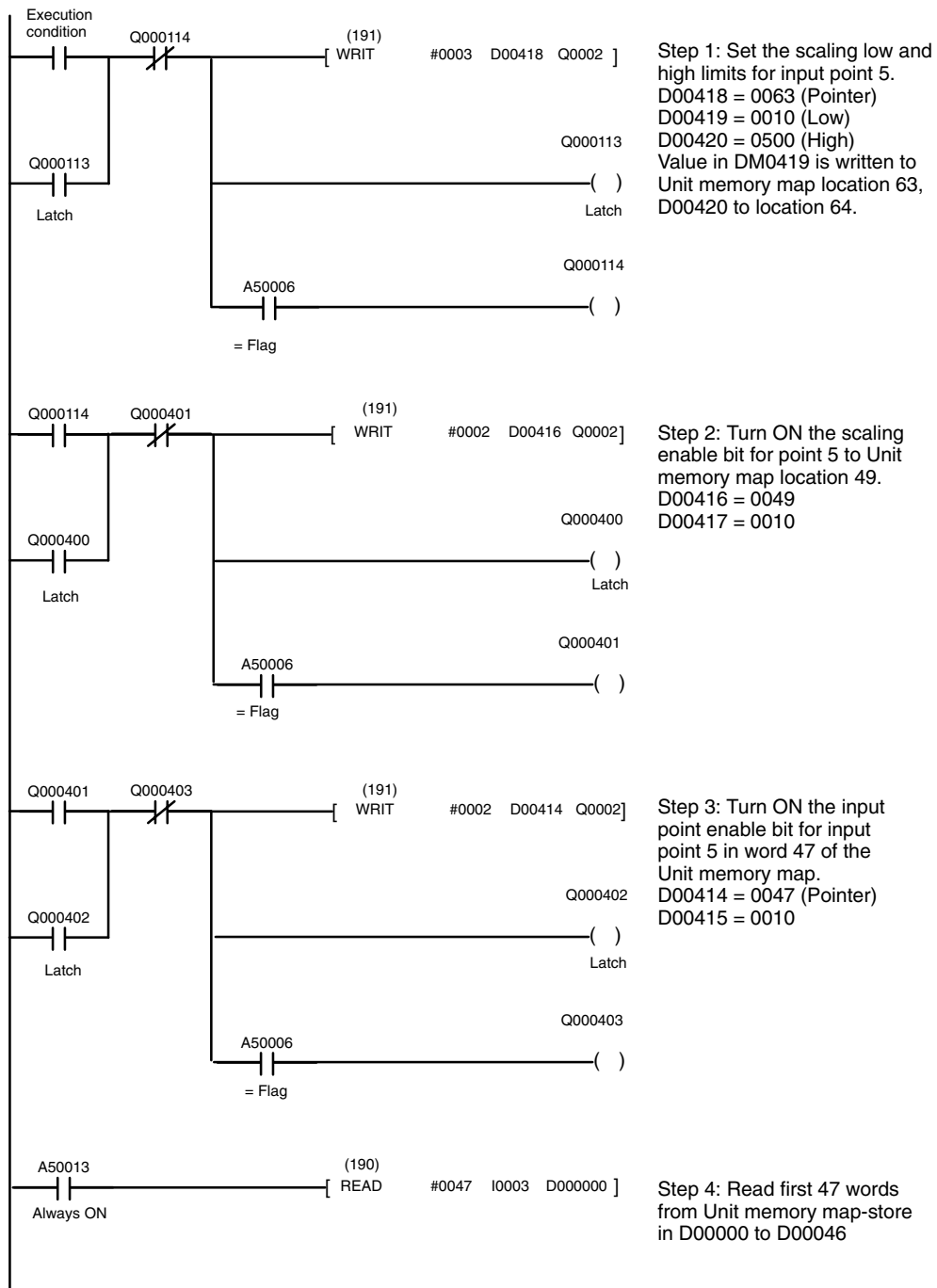

Step 1: Set the scaling low and high limits for input point 5.
 D00418 = 0063 (Pointer)
 D00419 = 0010 (Low)
 D00420 = 0500 (High)
 Value in DM0419 is written to Unit memory map location 63, D00420 to location 64.

Step 2: Turn ON the scaling enable bit for point 5 to Unit memory map location 49.
 D00416 = 0049
 D00417 = 0010

Step 3: Turn ON the input point enable bit for input point 5 in word 47 of the Unit memory map.
 D00414 = 0047 (Pointer)
 D00415 = 0010

Step 4: Read first 47 words from Unit memory map-store in D00000 to D00046

Example 2: Configuring the Alarm Function

This example shows how to configure the alarm function for specific input points. Refer to 5-6-6 High/Low Alarms for general information on using the high/low alarms.

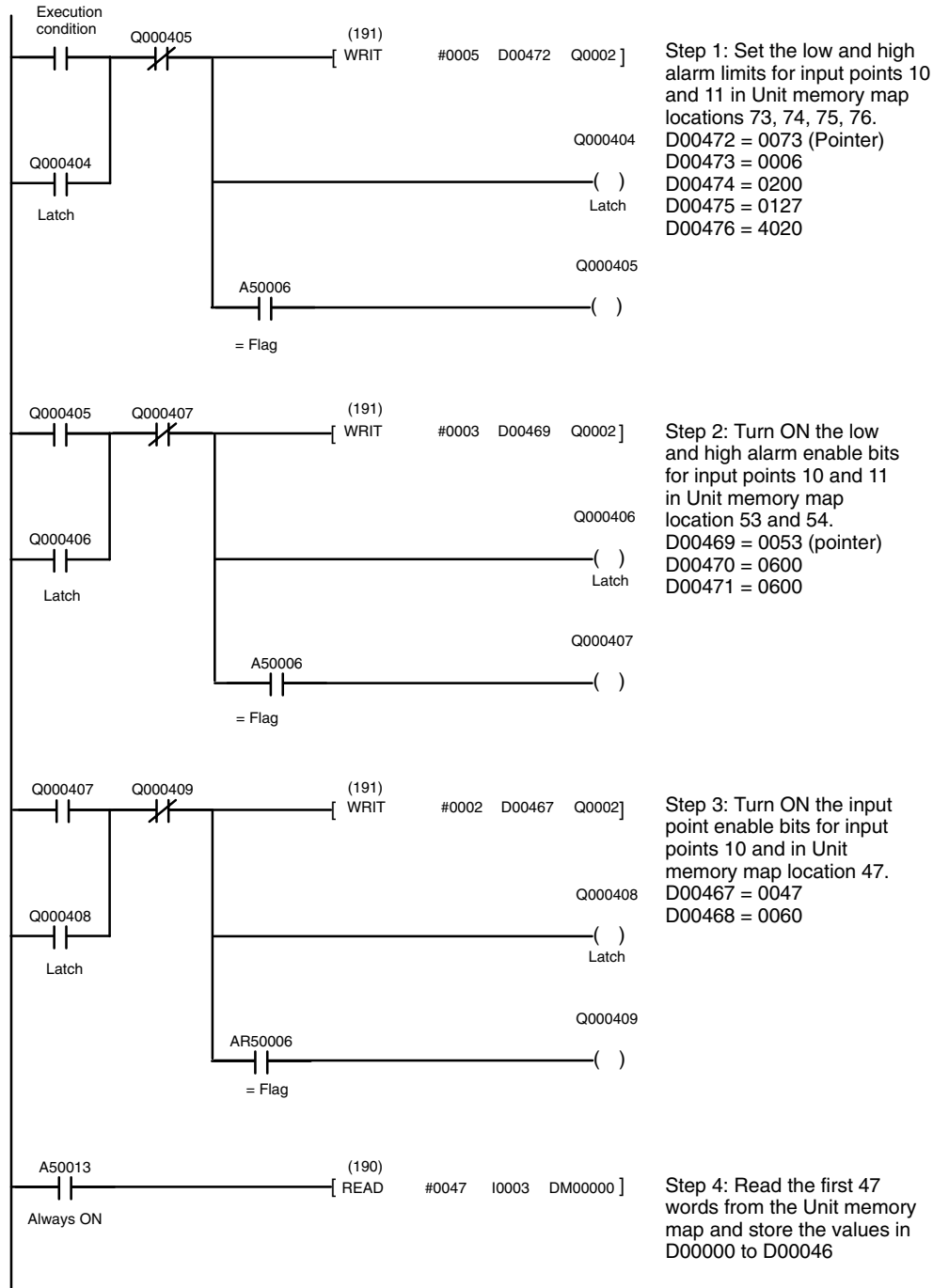

Example 3: Configuring the Filtering Function

This example shows how to configure the filtering function for specific input points. Refer to 5-6-4 *Filtering* for information on using the filtering function.

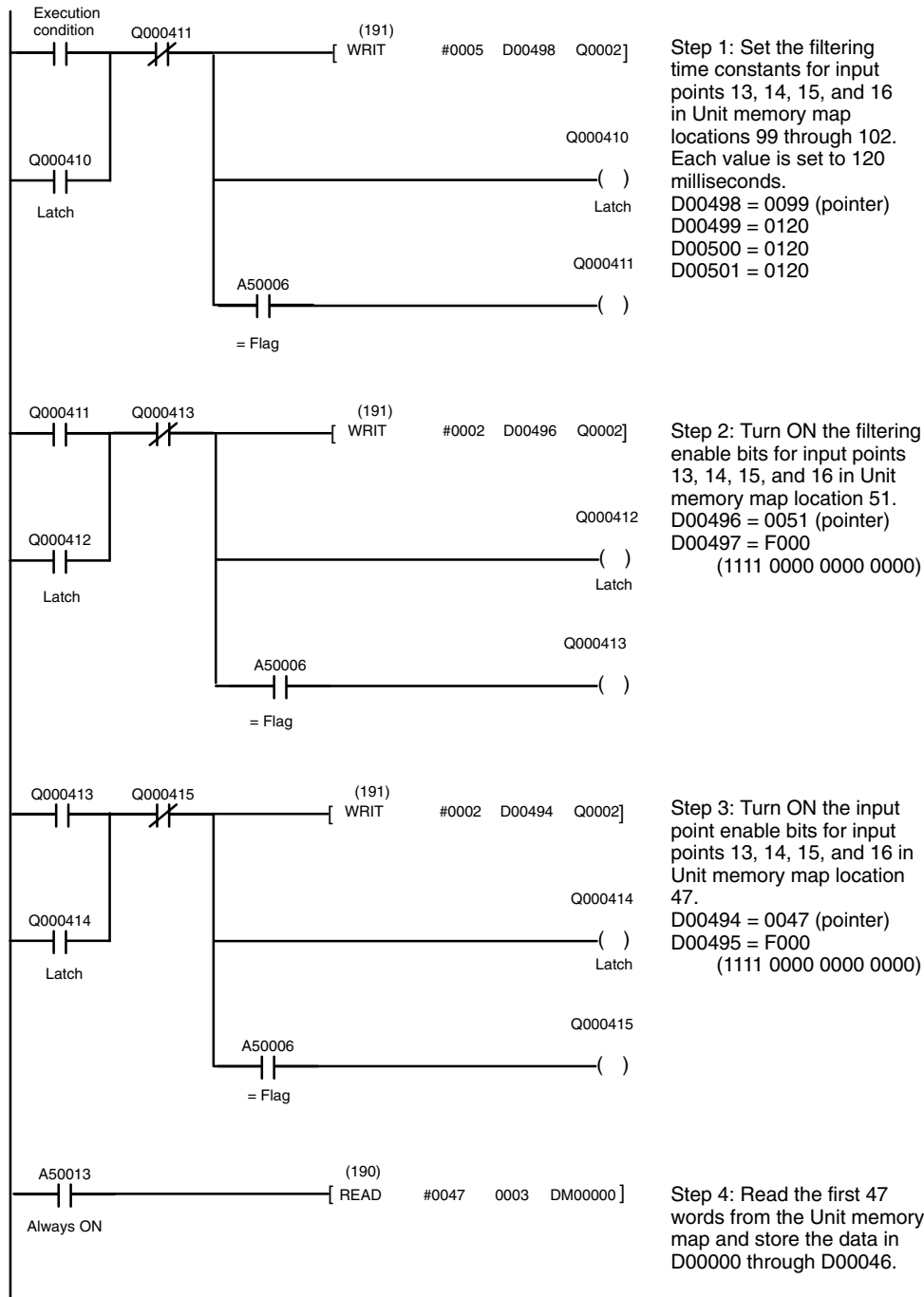

Example 4: Configuring the Averaging Function

This example shows how to configure the averaging function for specific input points. Refer to 5-6-3 *Averaging* for information on using the averaging function.

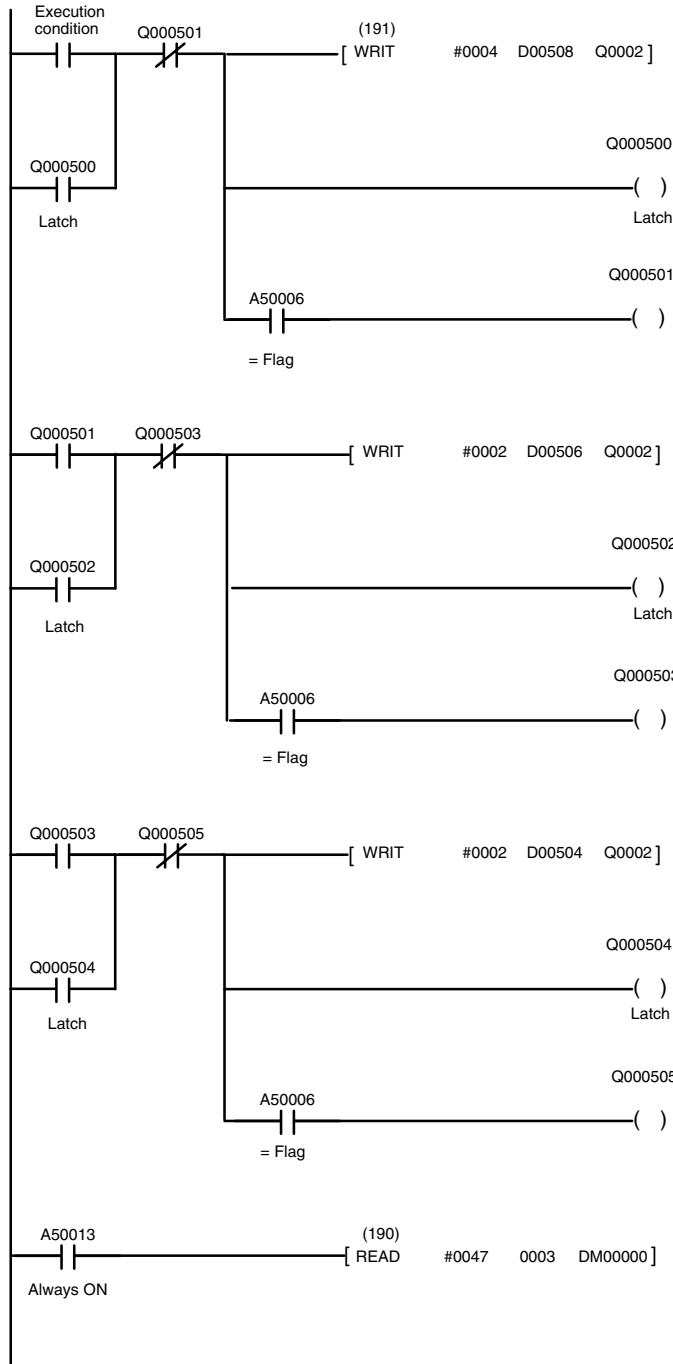

Step 1: Set the averaging sample counts for input points 7, 8, and 9 in Unit memory map locations 109, 110, and 111. The value is 25.
 D00508 = 0109 (pointer)
 D00509 = 0025
 D00510 = 0025
 D00511 = 0025

Step 2: Turn ON the averaging enable bits for input points 7, 8, and 9 in Unit memory map location 50.
 D00506 = 0050 (pointer)
 D00507 = 01C0
 (0000 0001 1100 0000)

Step 3: Turn ON the input point enable bits for input points 7, 8, and 9 in Unit memory map location 47.
 D00504 = 0047 (pointer)
 D00505 = 01C0
 (0000 0001 1100 0000)

Step 4: Read the first 47 words from the Unit memory map and store the values in D00000 to D00046.

SECTION 6

3G2A5-DA001 to 3G2A5-DA005 Analog Output Units

This section provides information on 3G2A5-DA001 to 3G2A5-DA005 Analog Output Units including the specifications, connections, IR/CIO bit allocations, and applications.

6-1	Specifications and General Information	106
6-1-1	Specifications	106
6-1-2	Description of Parts	107
6-1-3	Block Diagram	108
6-1-4	Wiring	109
6-2	IR/CIO Bit Allocations	110
6-3	Functions and User Programs	110
6-3-1	Output Signals and Converted Data	110
6-3-2	Ladder Programming Example	112

6-1 Specifications and General Information

6-1-1 Specifications

General Specifications

All general specifications of the 3G2A5-DA001 through 3G2A5-DA005 Analog Output Units conform to those of the C Series, except the following:

- Insulation between the External Terminals and the Frame:
5 M Ω min. at 250 VDC
- Breakdown Voltage between the External Terminals and the Frame:
500 VAC, 50-60 Hz for 1 minute

Performance Specifications

Item	Specification		
Number of analog outputs	2		
Output signal range	Voltage output	DA001	1 to 5 V
		DA002	0 to 10 V
		DA003	0 to 5 V
		DA004	-10 to 10 V
		DA005	-5 to 5 V
	Current output	DA001	4 to 20 mA
Max. output current	Voltage output	15 mA	
External output impedance	Voltage output	0.5 Ω max.	
Max. load resistance	Current output	550 Ω max.	
Resolution	1/4095 (full scale)		
PC signal (See note 1)	12-bit binary		
Linearity error	$\pm 1/2$ LSB max. (at 25°C)		
Accuracy	$\pm 0.2\%$ max. (full scale at 25°C)		
Accuracy temperature coefficient	± 50 PPM/°C		
Conversion time (See note 2)	5 ms max.		
Conversion cycle	CPU Unit program cycle time		
Words allocated	2 output words		
External connections	17-pin terminal block (not removable)		
Power consumption	550 mA max. at 5 VDC		
External dimensions	34.5 x 250 x 113 mm (W x H x D)		
Weight	600 g max.		

- Note**
1. A sign bit + 11 data bits binary data for Units with -10 to 10 V and -5 to 5 V range.
 2. Incorrect data results if the writing cycle is faster than the conversion time.

6-1-2 Description of Parts

3G2A5-DA001 to 3G2A5-DA005

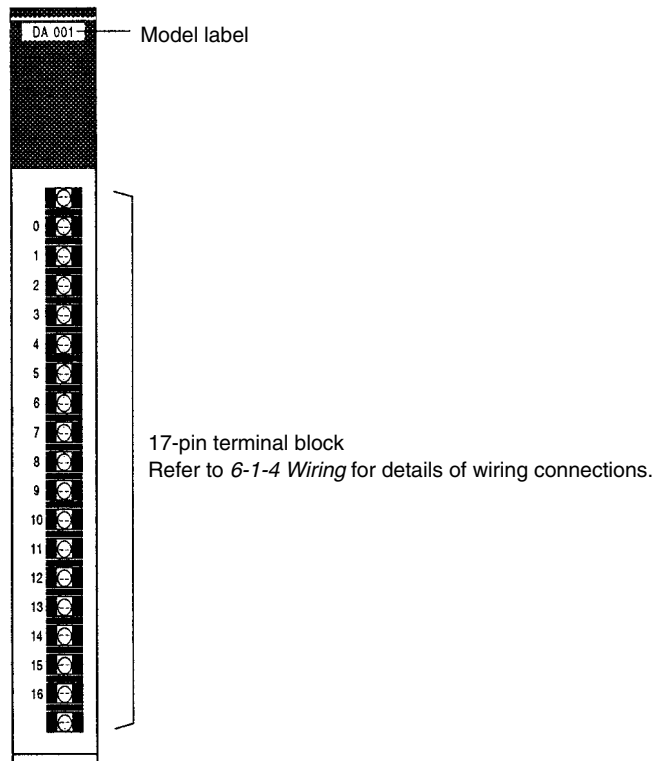

6-1-3 Block Diagram

The following diagram shows the basic internal connections of the Unit.

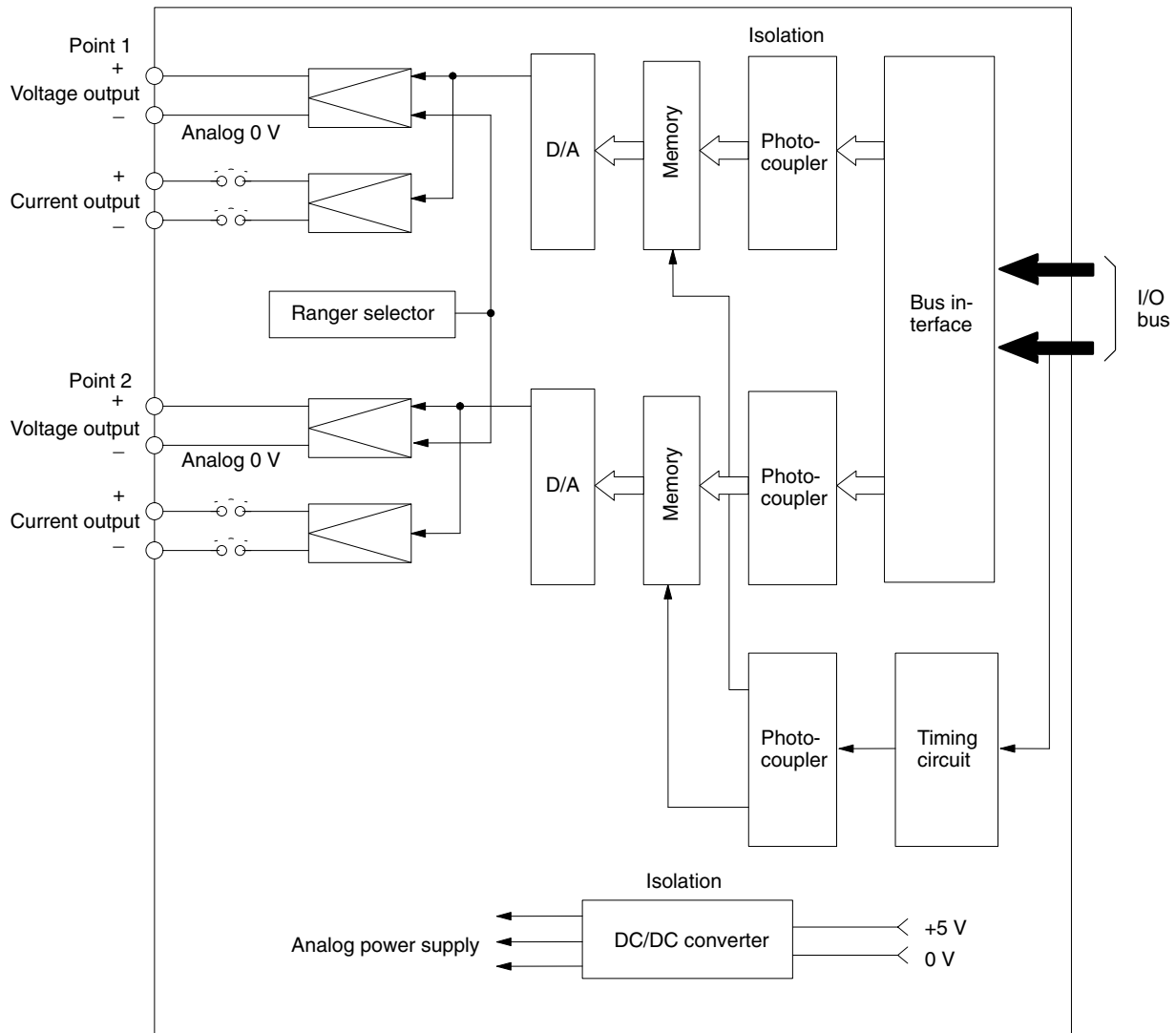

The current outputs are not connected in Units whose voltage output range is other than 1 to 5V.

6-1-4 Wiring

Voltage Outputs

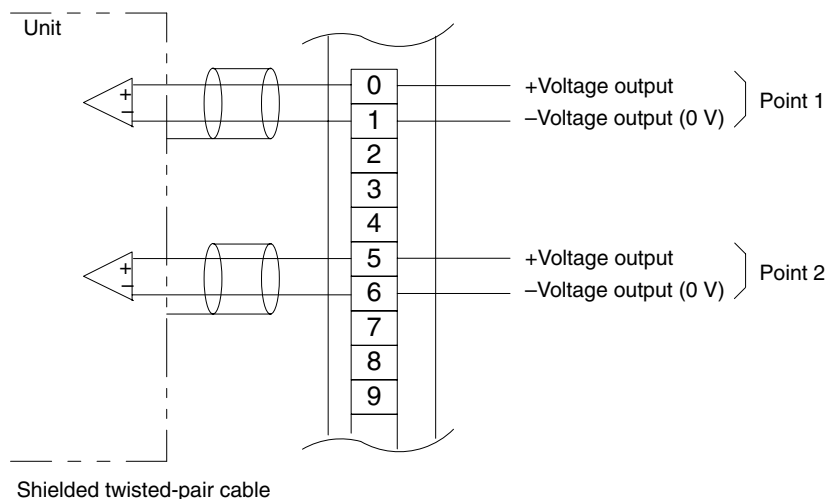

Current Outputs

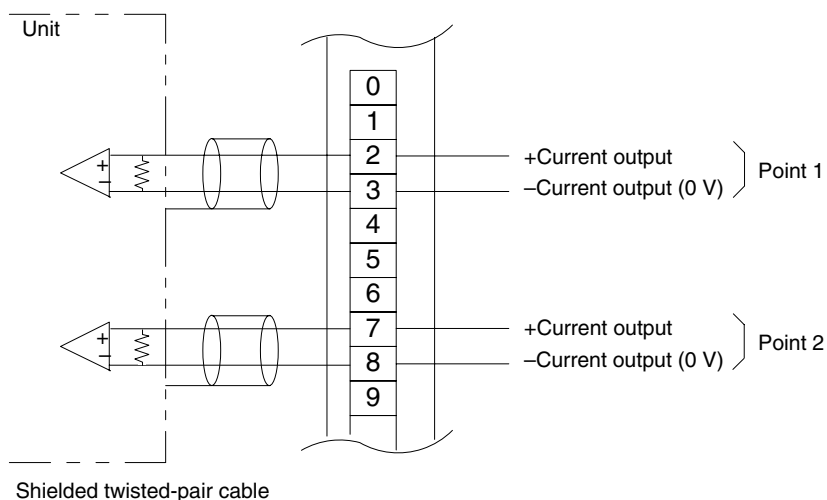

Precautions

- 1, 2, 3... 1. Use shielded twisted-pair cable for external connections.
2. Ground the shields to the load for both voltage and current outputs.
3. For current outputs, isolate the signal lines for each output point. These signal lines must also be isolated from the signal lines of other output circuits. If a negative current output terminal is shared between points 1 and 2, or if the negative current output terminal of a point is connected to another output circuit, interference will occur between both points or between a point and another output circuit, resulting in incorrect outputs.
4. A voltage (current) may be output momentarily from the output terminal when the power supply to the PC is turned ON or OFF. A maximum of 10 V will be output for several hundred milliseconds after the power is turned OFF and will gradually drop down to 0 V. If this causes a problem, provide countermeasures so that the power supply or output timing of external devices differs from the ON/OFF timing of the power supply at the PC.

6-2 IR/CIO Bit Allocations

Bit allocations for words that contain the values that will be converted to analog values for output from each Analog Output Unit output point are shown below.

Bit	Output words	
	IR/CIO n: Point 1	IR/CIO n+1: Point 2
0	D/A conversion data 2^0	D/A conversion data 2^0
1	D/A conversion data 2^1	D/A conversion data 2^1
2	D/A conversion data 2^2	D/A conversion data 2^2
3	D/A conversion data 2^3	D/A conversion data 2^3
4	D/A conversion data 2^4	D/A conversion data 2^4
5	D/A conversion data 2^5	D/A conversion data 2^5
6	D/A conversion data 2^6	D/A conversion data 2^6
7	D/A conversion data 2^7	D/A conversion data 2^7
8	D/A conversion data 2^8	D/A conversion data 2^8
9	D/A conversion data 2^9	D/A conversion data 2^9
10	D/A conversion data 2^{10}	D/A conversion data 2^{10}
11	D/A conversion data 2^{11}	D/A conversion data 2^{11}
12	0	0
13	0	0
14	0	0
15	0	0

Note For bipolar outputs, bit 11 is OFF for positive output values and ON for negative output values.

6-3 Functions and User Programs

6-3-1 Output Signals and Converted Data

The Analog Output Unit converts digital output data to analog signals. It converts the 12-bit binary data output by the CPU Unit program to either an voltage or current output. Five models are available to support different output ranges.

The analog output signals can be unipolar outputs which are positive, or bipolar outputs which are positive and negative. The resolution differs according to the output range.

Unipolar Output

Output Ranges: 1 to 5 V	3G2A5-DA001
4 to 20 mA	3G2A5-DA001
0 to 10 V	3G2A5-DA002
0 to 5 V	3G2A5-DA003

Converted Data: 12-bit binary input data

Relationship Between Input Data and Output Signals:

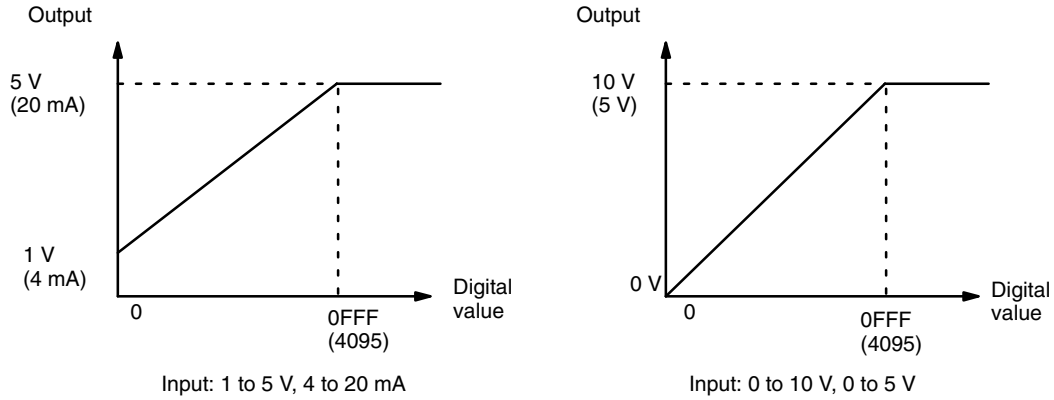

Note Data exceeding FFF_{Hex} (4095) cannot be converted.

Bipolar Output

Output Ranges: -10 to 10 V 3G2A5-DA004
 -5 to 5 V 3G2A5-DA005
 Converted Data: 1 sign bit + 11 bits binary input data
 Bit 11 is the sign bit: OFF for positive values
 ON for negative values

Relationship Between Input Data and Output Signals

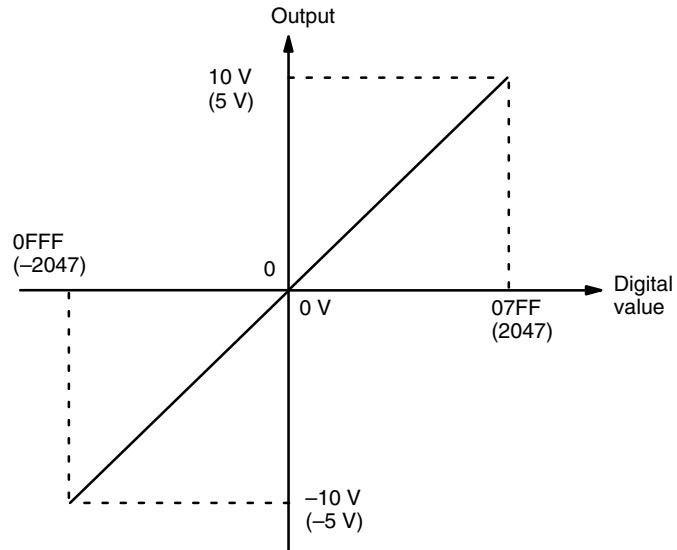

Note The numbers 2048 to 4095 (800_{Hex} to FFF_{Hex}) represent the values 0 to -2047. Data exceeding FFF_{Hex} (4095) cannot be converted.

6-3-2 Ladder Programming Example

The following example program converts two different 4-digit BCD values (4095 maximum) to analog signals and outputs the result.

Connections

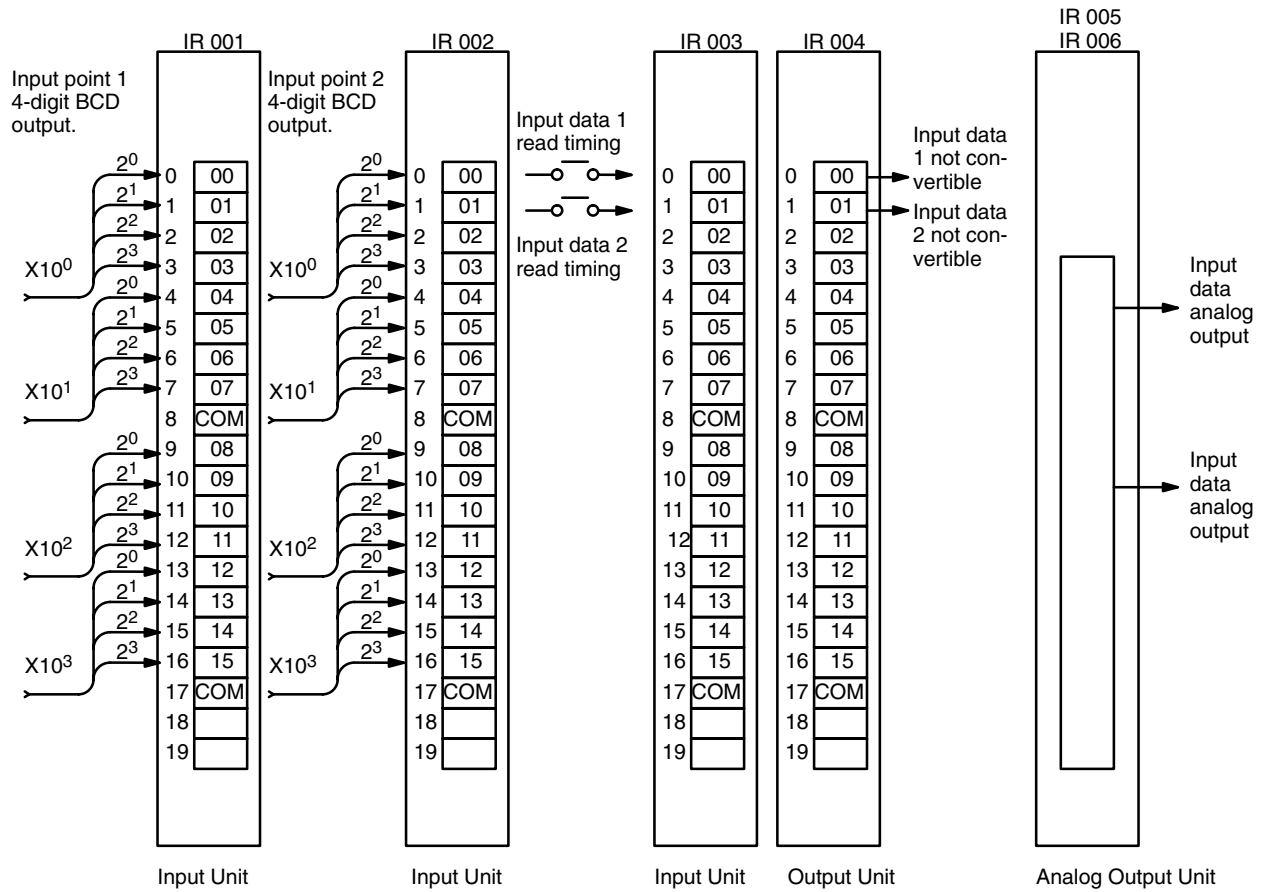

Programming Example Using C1000H

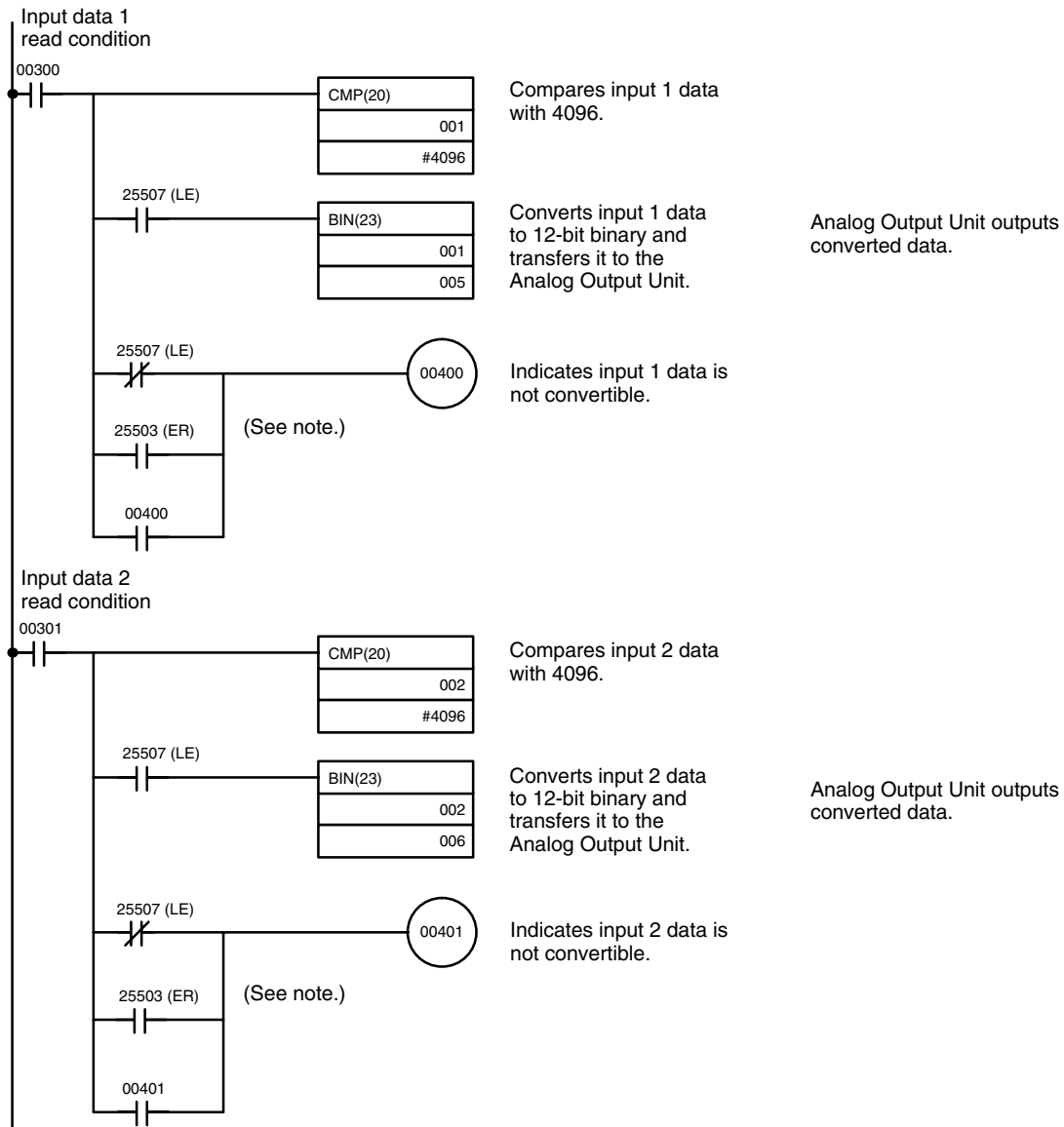

Note The Error Flag turns ON if the input data is not in BCD form.

SECTION 7

C500-DA101 Analog Output Unit

This section provides information on the C500-DA101 Analog Output Unit including the specifications, connections, IR/CIO bit allocations, and applications.

7-1	Specifications and General Information	116
7-1-1	Specifications	116
7-1-2	Description of Parts	117
7-1-3	Block Diagram	118
7-1-4	Setting Output Range	119
7-1-5	Wiring	120
7-2	IR/CIO Bit Allocations	122
7-3	Functions and User Programs	123
7-3-1	Operational Flow	123
7-3-2	Functions	123
7-3-3	Ladder Programming Example	124

7-1 Specifications and General Information

7-1-1 Specifications

General Specifications

All general specifications of the C500-DA101 Analog Output Unit conform to those of the C Series.

Performance Specifications

Item	Specification	
Number of analog outputs	4	
Output signal range	Voltage output	1 to 5 V 0 to 10 V
	Current output	4 to 20 mA
Max. output current	Voltage output	10 mA
External output impedance	Voltage output	0.5 Ω max.
Max. load resistance	Current output	400 Ω max.
Resolution	1/4095 (full scale)	
PC signal	12-bit binary	
Overall accuracy	25°C	$\pm 0.5\%$ max. (full scale, including linearity error)
	0 to 55°C	$\pm 1.0\%$ max. (full scale, including linearity error)
Conversion time (see note)	10 ms max./4 words (also 1 word)	
Words allocated	4 output words	
External connections	17-pin terminal block (not removable)	
Isolation	Between output terminals and CPU Unit: Photocoupler (no isolation between outputs)	
Power consumption	1.3 A max. at 5 VDC	
External dimensions	34.5 x 250 x 113 mm (W x H x D)	
Weight	650 g max.	

Note The conversion time is defined as the time to convert the output data written to the Analog Output Unit to full range (e.g., 1 to 10 V). Incorrect data results if the writing cycle is faster than the conversion time.

7-1-2 Description of Parts

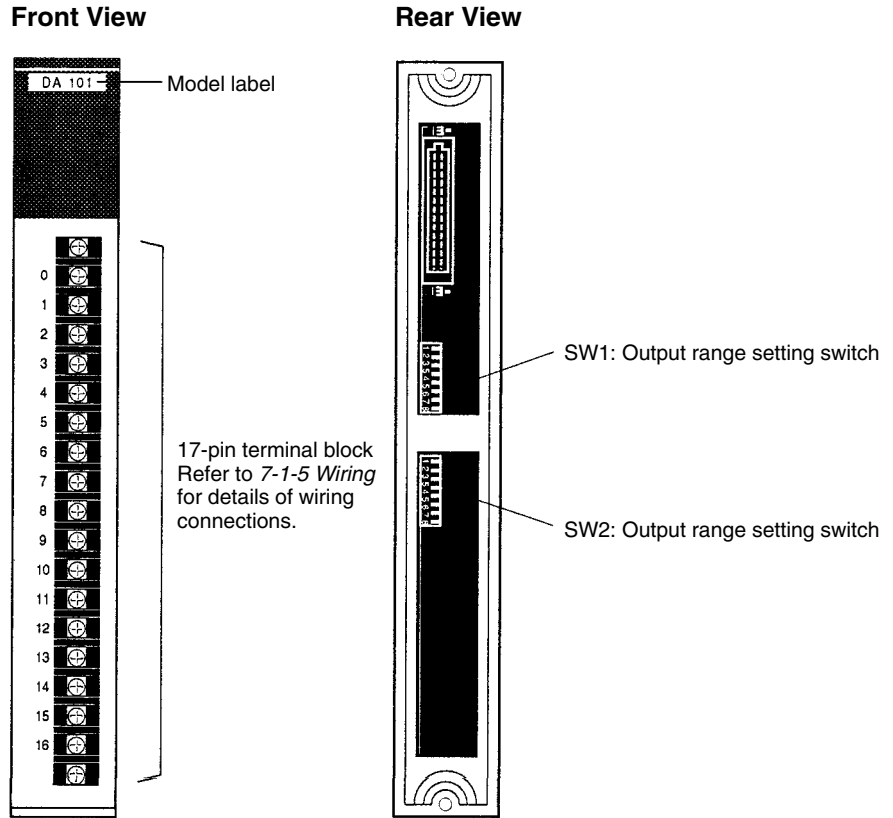

7-1-3 Block Diagram

The following diagram shows the basic internal connections of the Unit.

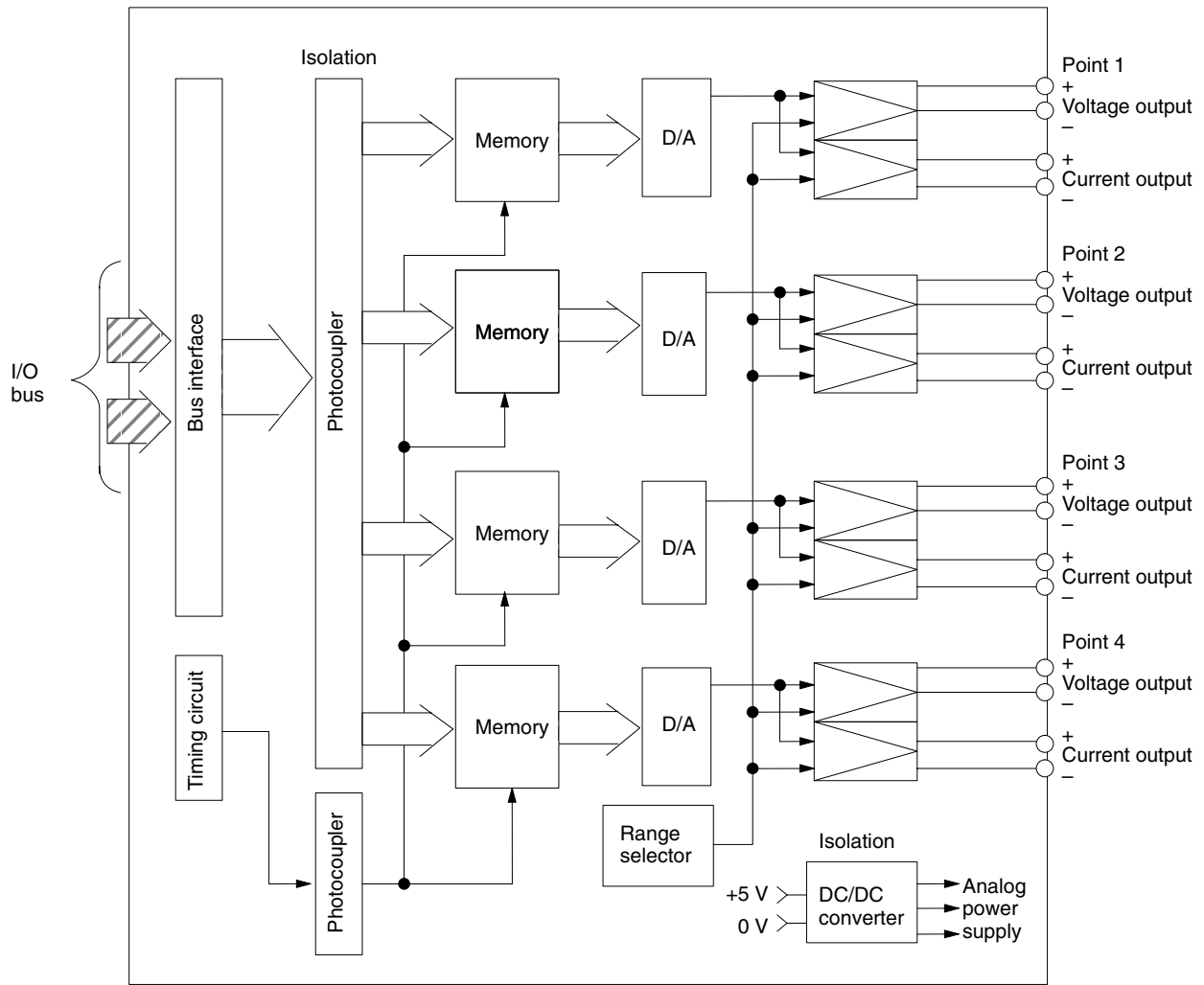

7-1-4 Setting Output Range

Set the output range for each output point using the DIP switches on the back of the Analog Output Unit.

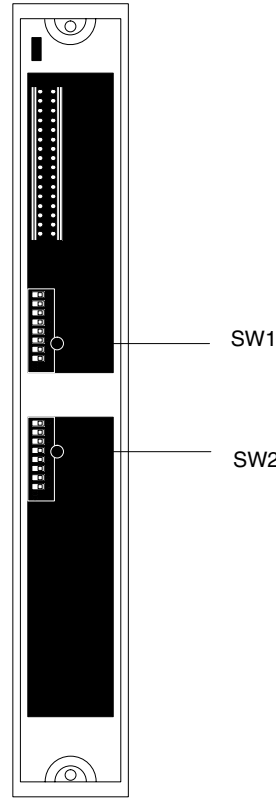

Back of Unit

DIP switch	Port	Pin	Output range		
			0 to 10 V	1 to 5 V	4 to 20 mA
SW1	1	1	OFF	ON	ON
		2	OFF	ON	ON
		3	OFF	OFF	ON
		4	ON	OFF	OFF
	2	5	OFF	ON	ON
		6	OFF	ON	ON
		7	OFF	OFF	ON
		8	ON	OFF	OFF
SW2	3	1	OFF	ON	ON
		2	OFF	ON	ON
		3	OFF	OFF	ON
		4	ON	OFF	OFF
	4	5	OFF	ON	ON
		6	OFF	ON	ON
		7	OFF	OFF	ON
		8	ON	OFF	OFF

The DIP switches are factory-set to the 1 to 5 V range. Change the switch settings to set the 1 to 5 V, 4 to 20 mA range.

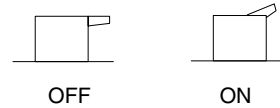

7-1-5 Wiring

Terminal Allocations

The terminals used depend on whether the output port 1 to 4 is a voltage output or current output.

Point	Output	Polarity	Terminal
1	Voltage output	+	0
		-	1
	Current output	+	2
		-	3
2	Voltage output	+	4
		-	5
	Current output	+	6
		-	7
3	Voltage output	+	8
		-	9
	Current output	+	10
		-	11
4	Voltage output	+	12
		-	13
	Current output	+	14
		-	15
Not used.			16

Wiring

Voltage Outputs

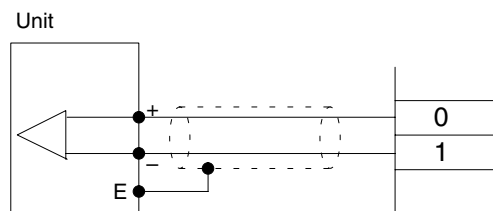

Current Outputs

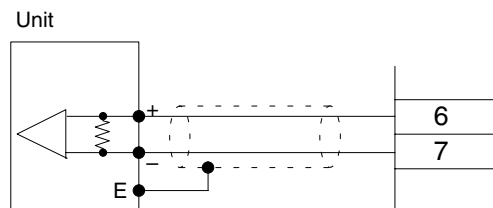

Precautions

- 1, 2, 3... 1. Use shielded twisted-pair cable for external connections to prevent induction and noise.
2. Do not run the Unit cables or near, or bundle them to, the main circuit cables or high-voltage cables.
3. Do not use the same cable for signal lines and AC wiring to external devices.
4. Ground shields to the Unit.

5. A voltage (current) may be output momentarily from the output terminal when the power supply to the PC is turned ON or OFF.
Approximately 1 V will be output for several hundred milliseconds after the power is turned ON or OFF.
If this causes a problem, provide countermeasures so that the power supply or output timing of external devices differs from the ON/OFF timing of the power supply at the PC.

7-2 IR/CIO Bit Allocations

Each C500-DA101 Analog Output Unit is allocated four words.

I/O bit	Output words			
	IR/CIO n: Point 1	IR/CIO n+1: Point 2	IR/CIO n+2: Point 3	IR/CIO n+3: Point 4
0	D/A conversion data 2^0	D/A conversion data 2^0	D/A conversion data 2^0	D/A conversion data 2^0
1	D/A conversion data 2^1	D/A conversion data 2^1	D/A conversion data 2^1	D/A conversion data 2^1
2	D/A conversion data 2^2	D/A conversion data 2^2	D/A conversion data 2^2	D/A conversion data 2^2
3	D/A conversion data 2^3	D/A conversion data 2^3	D/A conversion data 2^3	D/A conversion data 2^3
4	D/A conversion data 2^4	D/A conversion data 2^4	D/A conversion data 2^4	D/A conversion data 2^4
5	D/A conversion data 2^5	D/A conversion data 2^5	D/A conversion data 2^5	D/A conversion data 2^5
6	D/A conversion data 2^6	D/A conversion data 2^6	D/A conversion data 2^6	D/A conversion data 2^6
7	D/A conversion data 2^7	D/A conversion data 2^7	D/A conversion data 2^7	D/A conversion data 2^7
8	D/A conversion data 2^8	D/A conversion data 2^8	D/A conversion data 2^8	D/A conversion data 2^8
9	D/A conversion data 2^9	D/A conversion data 2^9	D/A conversion data 2^9	D/A conversion data 2^9
10	D/A conversion data 2^{10}	D/A conversion data 2^{10}	D/A conversion data 2^{10}	D/A conversion data 2^{10}
11	D/A conversion data 2^{11}	D/A conversion data 2^{11}	D/A conversion data 2^{11}	D/A conversion data 2^{11}
12	0	0	0	0
13	0	0	0	0
14	0	0	0	0
15	0	0	0	0

7-3 Functions and User Programs

7-3-1 Operational Flow

The C500-DA101 Analog Output Unit converts 12-bit binary data to voltage or current analog output signals. The Unit has four output points, each of which can be independently set to one of three ranges: 1 to 5 V or 0 to 10 V voltage output, or 4 to 20 mA current output.

The basic operational flow is described below.

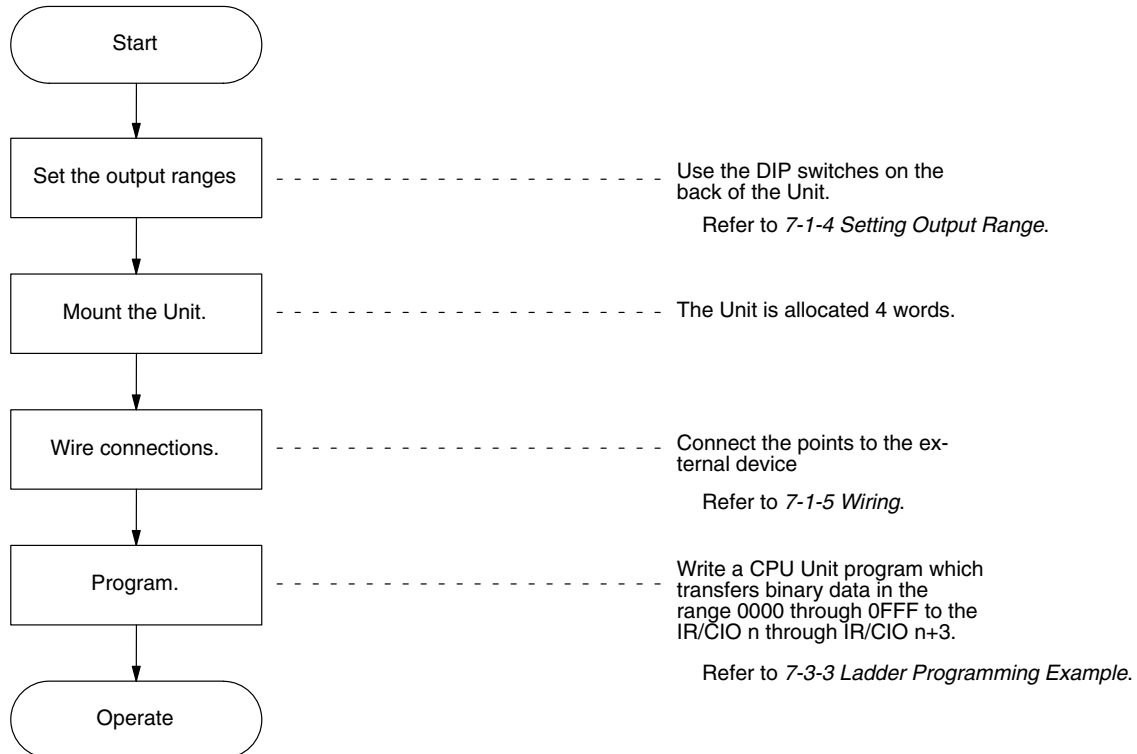

7-3-2 Functions

D/A Conversion

This Unit converts 3-digit hexadecimal values (0000 to 0FFF) from the specified words (IR/CIO n to n+3) for output from the Analog Output Unit. The output range depends on the setting of the DIP switches.

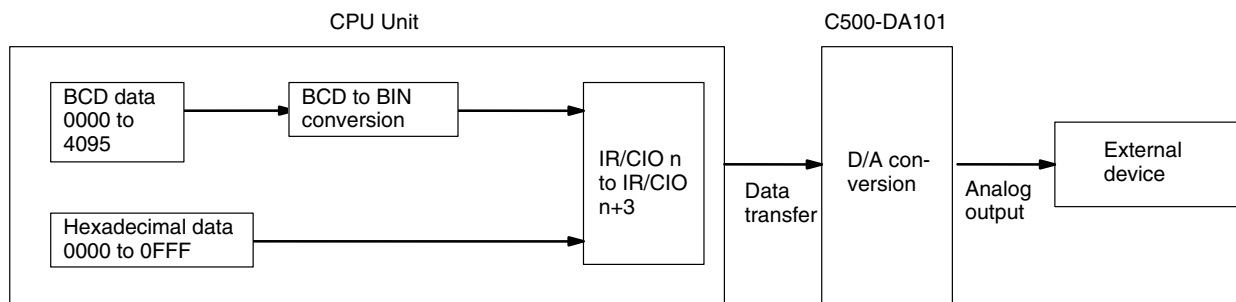

Relationship Between Input Data and Output Signals

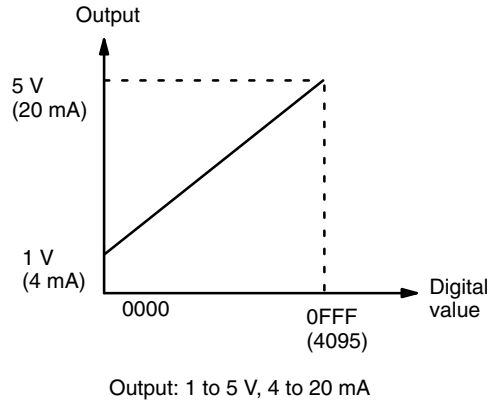
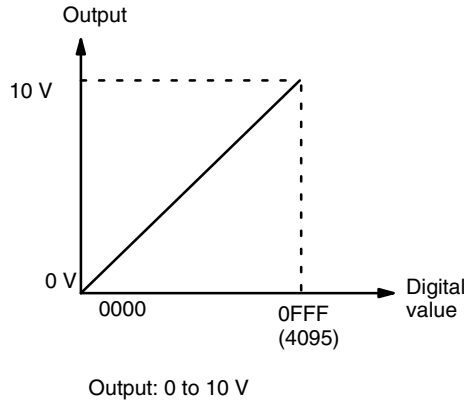

7-3-3 Ladder Programming Example

Example programs are shown below for the C500-DA101 Analog Output Unit mounted in the C1000H.

The conversion data is stored in DM 0100. The Unit uses IR 010 through IR 013. Only the programming for point 1 (IR 010) is shown.

Programming Examples Using C1000H

Program for BCD Data:

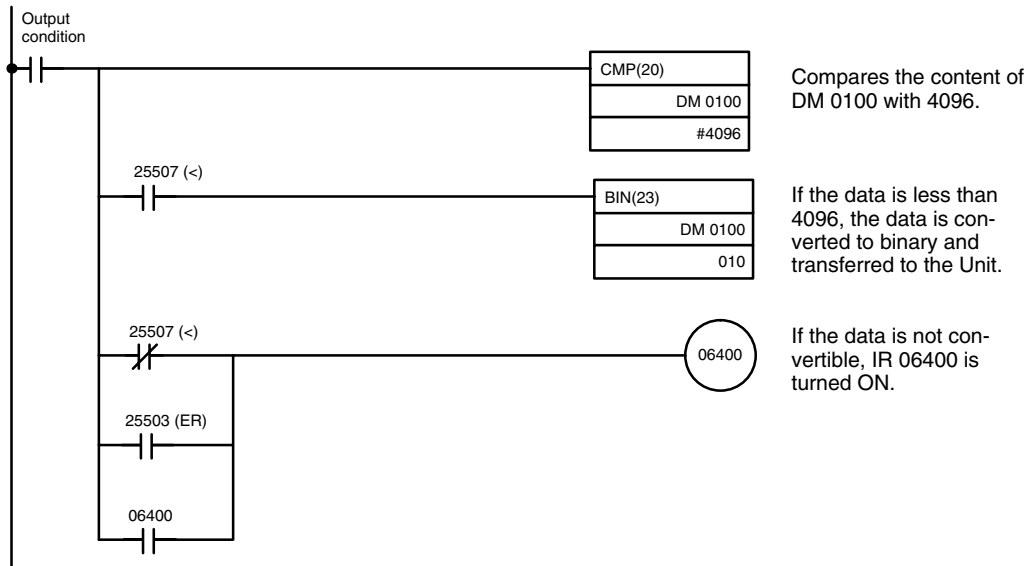

Program for Binary Data:

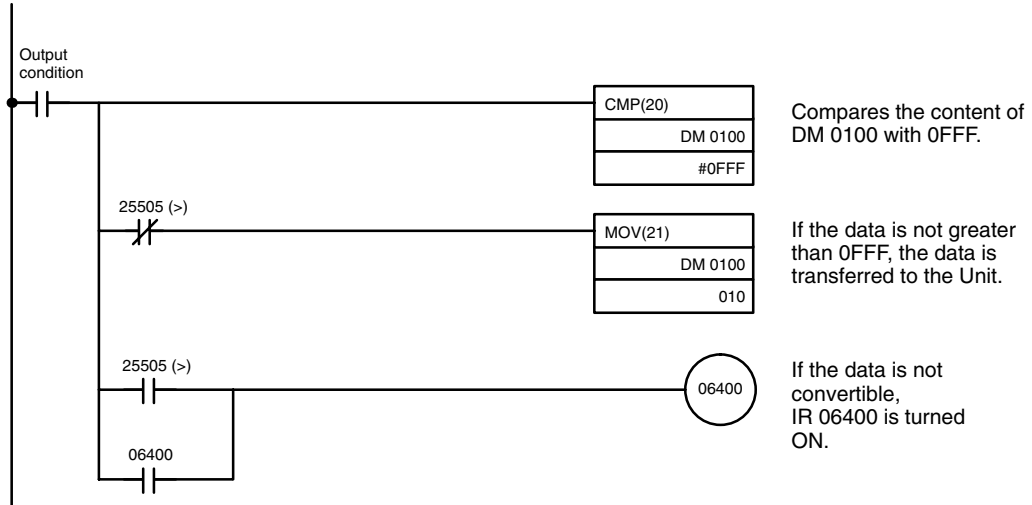

SECTION 8

C500-DA103 Analog Output Unit

This section provides information on the C500-DA103 Analog Output Unit including the specifications, connections, IR/CIO bit allocations, and applications.

8-1	Specifications and General Information	128
8-1-1	Specifications	128
8-1-2	Description of Parts	129
8-1-3	Block Diagram	130
8-1-4	Wiring	131
8-2	IR/CIO Bit Allocations	132
8-3	Functions and User Programs	132
8-3-1	Conversion Data and Output Signals	132
8-3-2	Ladder Programming Example	133

8-1 Specifications and General Information

8-1-1 Specifications

General Specifications

All general specifications of the C500-DA103 Analog Output Unit conform to those of the C Series.

Performance Specifications

Item	Specification	
Number of analog outputs	4	
Output signal range	Voltage output	−10 to 10 V
Max. output current	±5 mA	
External output impedance	0.5 Ω max.	
Resolution	1/4095 (full scale)	
PC signal	1 sign bit + 11-bit binary	
Overall accuracy	25°C	±0.5% max. (full scale, including linearity error)
	0 to 55°C	±1.0% max. (full scale, including linearity error)
Conversion time	10 ms max./4 words (also 1 word)	
Words allocated	4 output words	
External connections	17-pin terminal block (not removable)	
Isolation	Between output terminals and CPU Unit: Photocoupler (no isolation between outputs)	
Power consumption	1.3 A max. at 5 VDC	
External dimensions	34.5 x 250 x 113 mm (W x H x D)	
Weight	650 g max.	

Note The conversion time is defined as the time to convert the output data written to the Analog Output Unit to full range (e.g., −10 to 10 V). Incorrect data results if the writing cycle is faster than the conversion time.

8-1-2 Description of Parts

C500-DA103

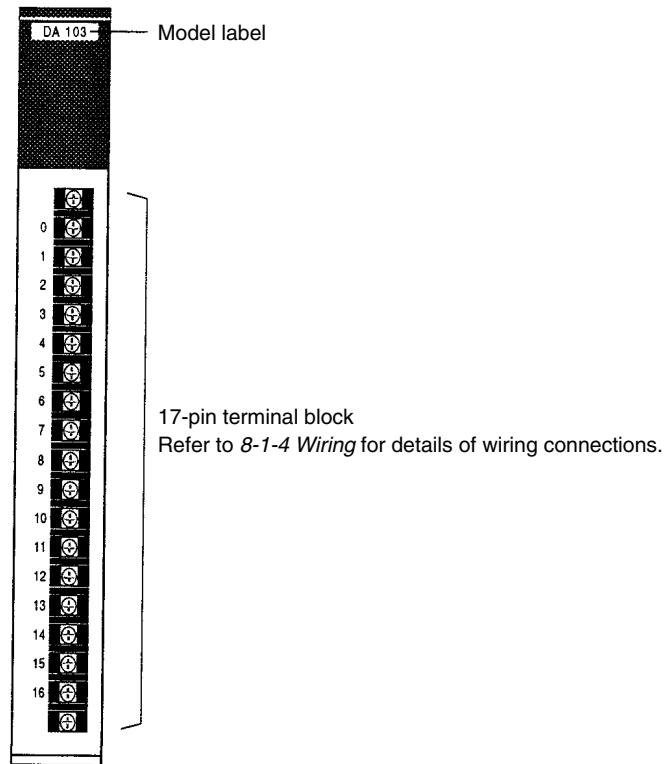

8-1-3 Block Diagram

The following diagram shows the basic internal connections of the Unit.

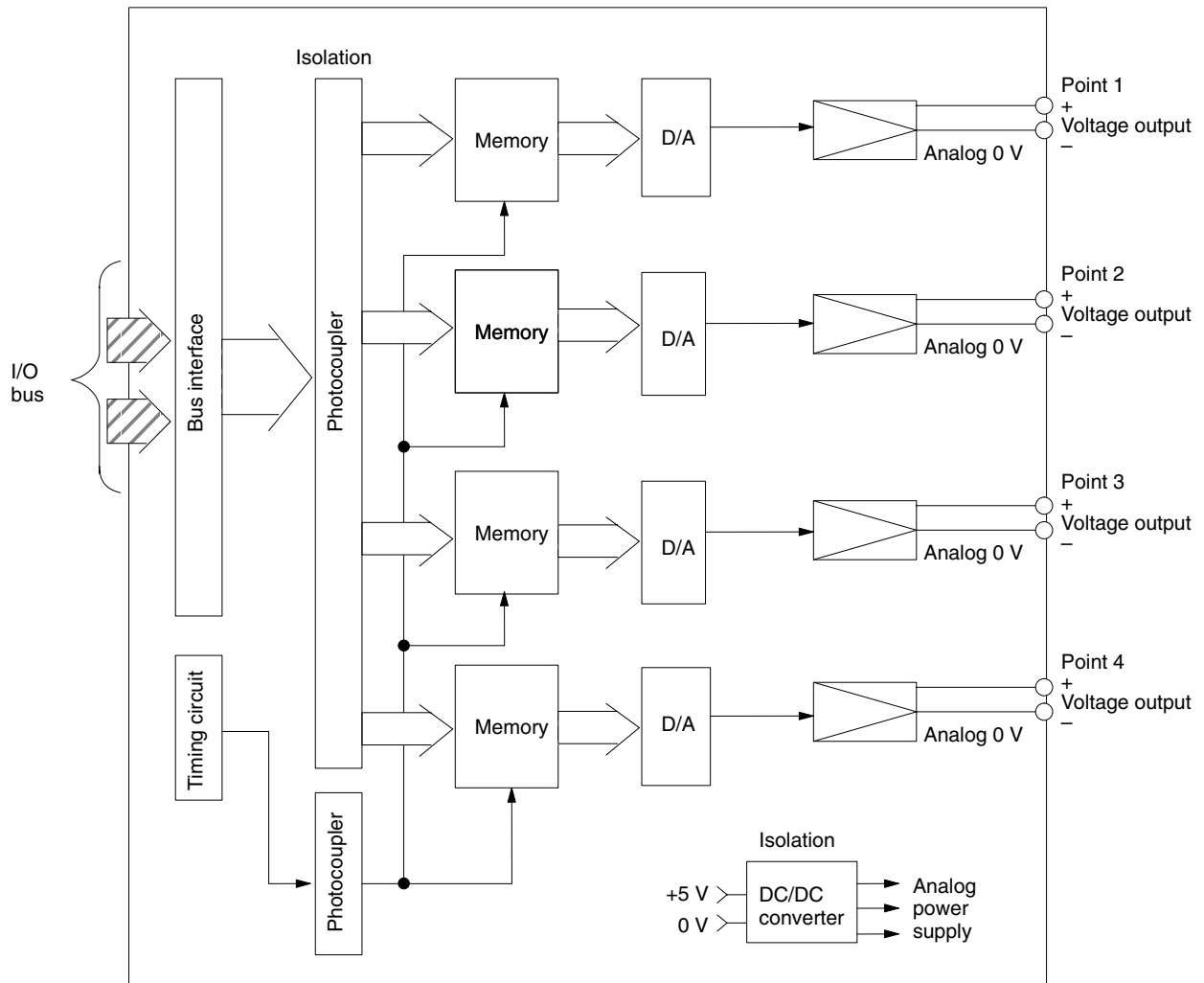

8-1-4 Wiring

Terminal Allocations

Terminal Number	Description
0	+Voltage output for point 1
1	-Voltage output for point 1
2	Not used
3	Not used
4	+Voltage output for point 2
5	-Voltage output for point 2
6	Not used
7	Not used
8	+Voltage output for point 3
9	-Voltage output for point 3
10	Not used
11	Not used
12	+Voltage output for point 4
13	-Voltage output for point 4
14	Not used
15	Not used
16	Not used

Voltage Outputs

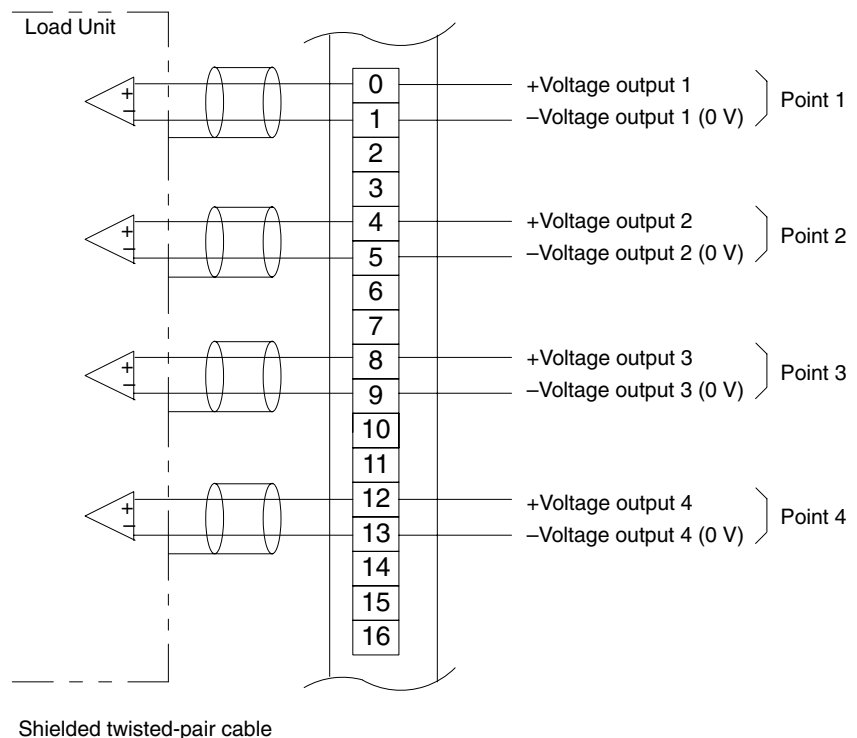

Precautions

- 1, 2, 3... 1. Use shielded twisted-pair cable for external connections to prevent induction and noise.
2. Ground shields to the Load Unit.
3. Consider the Load Unit impedance to ensure that the current does not exceed the prescribed limit.
4. Pass the output wires through a different duct from the high-voltage and power cables.

8-2 IR/CIO Bit Allocations

IR/CIO Bit Allocations

Each C500-DA103 Analog Output Unit is allocated four words.

Bit	Output words			
	IR/CIO n: Point 1	IR/CIO n+1: Point 2	IR/CIO n+2: Point 3	IR/CIO n+3: Point 4
0	D/A conversion data 2^0	D/A conversion data 2^0	D/A conversion data 2^0	D/A conversion data 2^0
1	D/A conversion data 2^1	D/A conversion data 2^1	D/A conversion data 2^1	D/A conversion data 2^1
2	D/A conversion data 2^2	D/A conversion data 2^2	D/A conversion data 2^2	D/A conversion data 2^2
3	D/A conversion data 2^3	D/A conversion data 2^3	D/A conversion data 2^3	D/A conversion data 2^3
4	D/A conversion data 2^4	D/A conversion data 2^4	D/A conversion data 2^4	D/A conversion data 2^4
5	D/A conversion data 2^5	D/A conversion data 2^5	D/A conversion data 2^5	D/A conversion data 2^5
6	D/A conversion data 2^6	D/A conversion data 2^6	D/A conversion data 2^6	D/A conversion data 2^6
7	D/A conversion data 2^7	D/A conversion data 2^7	D/A conversion data 2^7	D/A conversion data 2^7
8	D/A conversion data 2^8	D/A conversion data 2^8	D/A conversion data 2^8	D/A conversion data 2^8
9	D/A conversion data 2^9	D/A conversion data 2^9	D/A conversion data 2^9	D/A conversion data 2^9
10	D/A conversion data 2^{10}	D/A conversion data 2^{10}	D/A conversion data 2^{10}	D/A conversion data 2^{10}
11	0	0	0	0
12	0	0	0	0
13	0	0	0	0
14	0	0	0	0
15	Sign bit	Sign bit	Sign bit	Sign bit

Note Bit 15 is the sign bit: OFF for positive values
ON for negative values

8-3 Functions and User Programs

8-3-1 Conversion Data and Output Signals

The C500-DA103 Analog Output Unit converts digital data to analog output signals.

Function

This Unit converts 4-digit hexadecimal values (0000 to 07FF or 8000 to 87FF) from the specified words (IR/CIO n to n+3) for output from the Analog Output Unit.

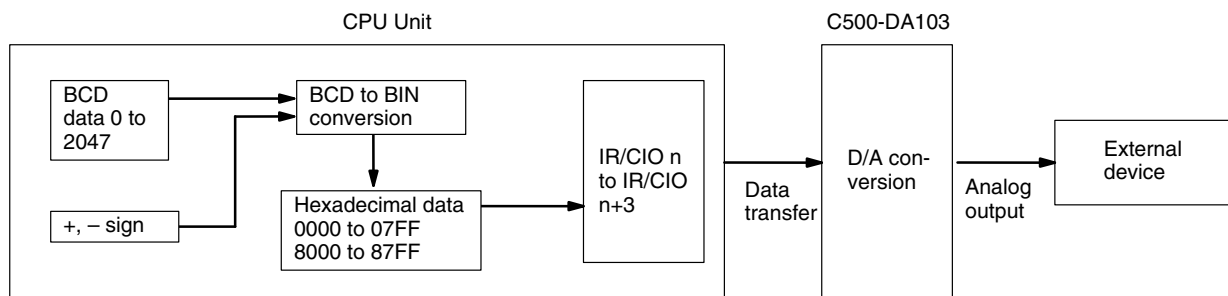

Relationship Between Input Data and Output Signals

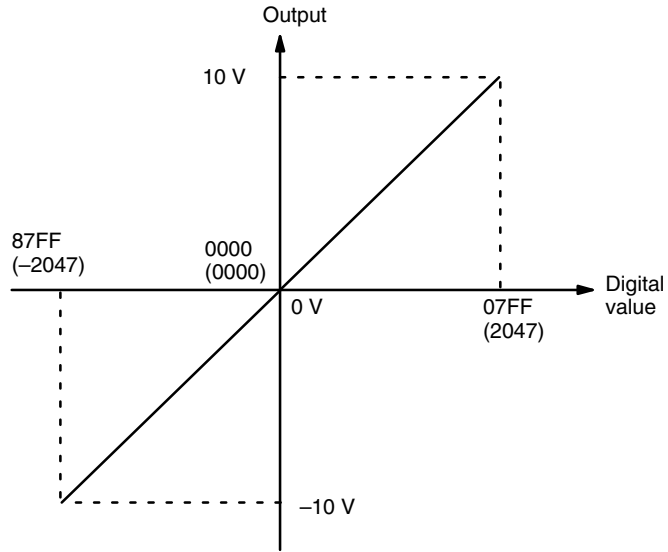

$07FF_{Hex} = 2047$ is converted to 10 V
 0000_{Hex} and $8000_{Hex} = 0$ and -0 are converted to 0 V
 $87FF_{Hex} = -2047$ is converted to -10 V
 Data cannot be converted in ranges 0800_{Hex} to $7FFF_{Hex}$ or 8800_{Hex} to $FFFF_{Hex}$.

8-3-2 Ladder Programming Example

Example programs are shown below for the C500-DA103 Analog Output Unit mounted in the C1000H.
 The conversion data is stored in DM 0100. The Unit uses IR 000 through IR 003.
 Only the programming for point 1 (IR 000) is shown.

Programming Example Using C1000H

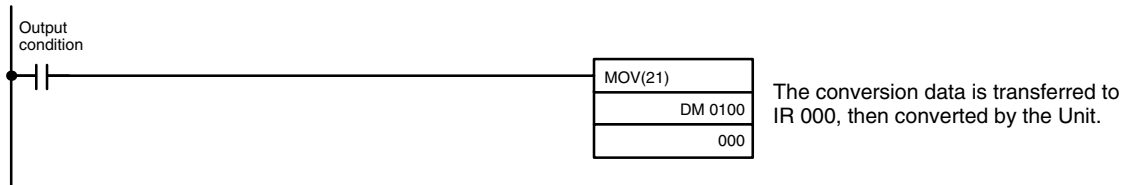

SECTION 9

C500-DA501 Analog Output Unit

This section describes information on the C500-DA501 Analog Output Unit including the specifications, connections, I/O word allocations, and applications.

9-1	Specifications and General Information	136
9-1-1	Specifications	136
9-1-2	Overview	141
9-1-3	Description of Parts	142
9-1-4	Indicators	142
9-1-5	Block Diagram	143
9-1-6	Internal Structure	144
9-1-7	Operation Flow	146
9-2	Settings and Wiring	147
9-2-1	Setting the Output Signal Ranges	147
9-2-2	Setting the Two-word or Four-word Operating Mode	149
9-2-3	Setting the Output Signals at PC Power Interruption and Recovery	150
9-2-4	Wiring	151
9-3	Data Exchange with CPU Unit	153
9-3-1	Basic Operation	154
9-3-2	IR/CIO Bit Allocations	163
9-3-3	Memory Map	167
9-4	Functions	175
9-4-1	BCD/Binary Mode	175
9-4-2	Scaling	175
9-4-3	Output Ramps	177
9-4-4	Upper/Lower Limits	179
9-5	User Programming Examples	182
9-5-1	Two-word Operating Mode	182
9-5-2	Four-word Operating Mode	184
9-5-3	Using Pulse Signals	189
9-5-4	Writing EEPROM	190

9-1 Specifications and General Information

9-1-1 Specifications

General Specifications

All general specifications of the C500-DA501 Analog Output Unit conform to those of the C Series, except the following:

Item	Specification
Ambient operating temperature	8 points with voltage outputs: 0 to 55°C
	4 points with voltage or current outputs: 0 to 50°C
	8 points with current outputs: 0 to 45°C

Performance Specifications

Item	Specification		
Number of analog output points	8		
Output signal range	Voltage outputs	0 to 10 V 0 to 5 V -5 to 5 V -10 to 10 V	Settable as shown on the left for each output point. (All 8 output points are factory-set to 0 to 10 V.) Voltage outputs: The range is set using the DIP switches on the rear panel and the voltage output range short-circuit pins on the front panel. Current outputs: The range is set using the DIP switches on the rear panel.
	Current outputs	0 to 20 mA 4 to 20 mA	
Max. output current	Voltage outputs	10 mA	
External output impedance	Voltage outputs	0.5 Ω max.	
Max. load resistance	Current outputs	750 Ω max.	
	Voltage outputs	10 kΩ min.	
Power supply from PC	5 VDC (supplied from Backplane)		
External power supply	24 VDC ±5%		
Resolution	1/4095 (full scale)		
Conversion data ranges	Without Scaling		
	Voltage outputs	0 to 10 V 0 to 5 V	BCD mode: Unsigned decimal values in BCD, 0 to 4095 (0000 to 4095 _{Hex}) Binary mode: Unsigned decimal values in binary, 0 to 4095 (0000 to 0FFF _{Hex}) (BCD or binary can be set for each output point.)
		Current outputs	
	Voltage outputs	-5 to 5 V -10 to 10 V	BCD mode: Signed decimal values in BCD, -2048 to 2047 (A048 to 2047 _{Hex}) Binary mode: Signed decimal values in binary, -2048 to 2047 (F800 to 07FF _{Hex}) (BCD or binary can be set for each output point.)
		With Scaling	
Range: Scaling lower limit to scaling upper limit (see note below) The upper and lower limits must be within the following ranges. BCD mode: Decimal values -7999 to 7999 (F999 to 7999 _{Hex}) Binary mode: Decimal values -32767 to 32767 (8001 to 7FFF _{Hex}) Note: The scaling lower limit can be greater than the scaling upper limit, in which case reverse scaling will be performed.			

Item	Specification		
Overall accuracy (full scale)	Voltage outputs	0 to 10 V 0 to 5 V -5 to 5 V -10 to 10 V	0.1% (at 25°C), 0.4% (at 0 to 55°C)
	Current outputs	0 to 20 mA 4 to 20 mA	0.4% (at 0 to 55°C)
Reproducibility	0.0047% (full range)		
Conversion time	Normal/BCD mode: 13.4 ms (With output ramp and upper/lower limits: 16.6 ms) High-speed mode: 3.4 ms		
Words allocated	2 words (1 input word and 1 output word) or 4 words (2 input words and 2 output words) Set using the two/four-word operating mode short-circuit pins on the front panel. Factory-set to two-word operating mode.		
Data exchange with CPU Unit	Two-word operating mode (factory setting): The CPU Unit directly accesses the Memory Map in RAM using the I/O WRITE and I/O READ instructions, WRIT and READ. Four-word operating mode: The CPU Unit accesses the Memory Map in RAM via the allocated I/O words using the MOV and other instructions.		
Internal memory	RAM	62 words: Consists of data that can be accessed by CPU Unit using the above instructions, including conversion data, scaling upper/lower limits, upper/lower limit values, BCD mode parameters, binary mode parameters, etc.	
	EEPROM	Contains parameter data that can be written from RAM. It transfers data back to RAM when the power is turned ON.	
Mountable Racks	Two-word operating mode: CPU Rack, Expansion CPU Rack, Expansion I/O Rack, and SYSMAC BUS/2 Slave Rack (Cannot be mounted to a SYSMAC BUS Slave Rack.) Four-word operating mode: CPU Rack, Expansion CPU Rack, Expansion I/O Rack, and SYSMAC BUS Slave Rack		
Special functions	BCD/binary mode selection (Set for each point)	Specifies whether conversion data, scaling upper and lower limits, upper and lower limit values, and output ramp set time are to be handled as BCD or binary data.	
	Scaling (Set for each point)	Initially sets 16-bit upper and lower limits as a scale and automatically performs scaling for conversion data (converts it to a rate of 0% to 100%) according to the initial settings. If lower limit > upper limit, reverse scaling will be performed (lower limit: 100%, upper limit: 0%). BCD mode: Decimal values -7999 to 7999 (F999 to 7999 _{Hex}) (see note 1) Binary mode: Decimal values -32767 to 32767 (B001 to 7FFF _{Hex}) (see note 2) Note 1: Bit 15 is the sign (0: +, 1: -). Note 2: Two's complement	
	Output ramp (Set for each point)	Makes output signals change at a specified rate to prevent sudden changes in response to changes in the present value. Set the time required to change a present value to a new value. BCD mode: 8 to 7,999 ms Binary mode: 8 to 32,767 ms (see 4-3 Two-word Operation for details.)	
	Upper/lower limits (Set for each point)	Makes output signal values constant when conversion data goes beyond a certain range. (This function can be combined with the scaling function.) The upper and lower limits can be set within the set data or scaling data range provided that the upper limit is greater than the lower limit.	
	Conversion time switching	Switches the D/A conversion time between normal speed and high speed.	
	EEPROM	Writes data from RAM to EEPROM (according to the EEPROM Write Bit setting in the allocated I/O words). Data is automatically read from EEPROM to RAM when the power is turned ON. This makes it unnecessary to transfer parameter data from the ladder program each time.	

Item	Specification
Output signals when PC is turned OFF	0 V or 0 mA (factory setting) Output signal value immediately before power is interrupted is maintained as long as 5-V power from PC to Unit is ON, and then 0 V or 0 mA is output. Either 0 V or 0 mA can be selected using the toggle switch on the back of the Unit.
External connections	38-pin terminal block (detachable)
Isolation	Between output terminal and power supply, between output terminals, between external power supply and power supply: Photocoupler Between external power supply and output terminal: Transformer
Power consumption	Power supply from Rack: 0.3 A max. at 5 VDC External power supply: 0.8 A max. at 24 VDC
Dimensions	34.5 × 250 × 120 mm (W × H × D)
Weight	700 g max.

Output Specifications

The output specifications of the C500-DA501 Analog Output Unit without scaling are shown below.

Voltage Outputs

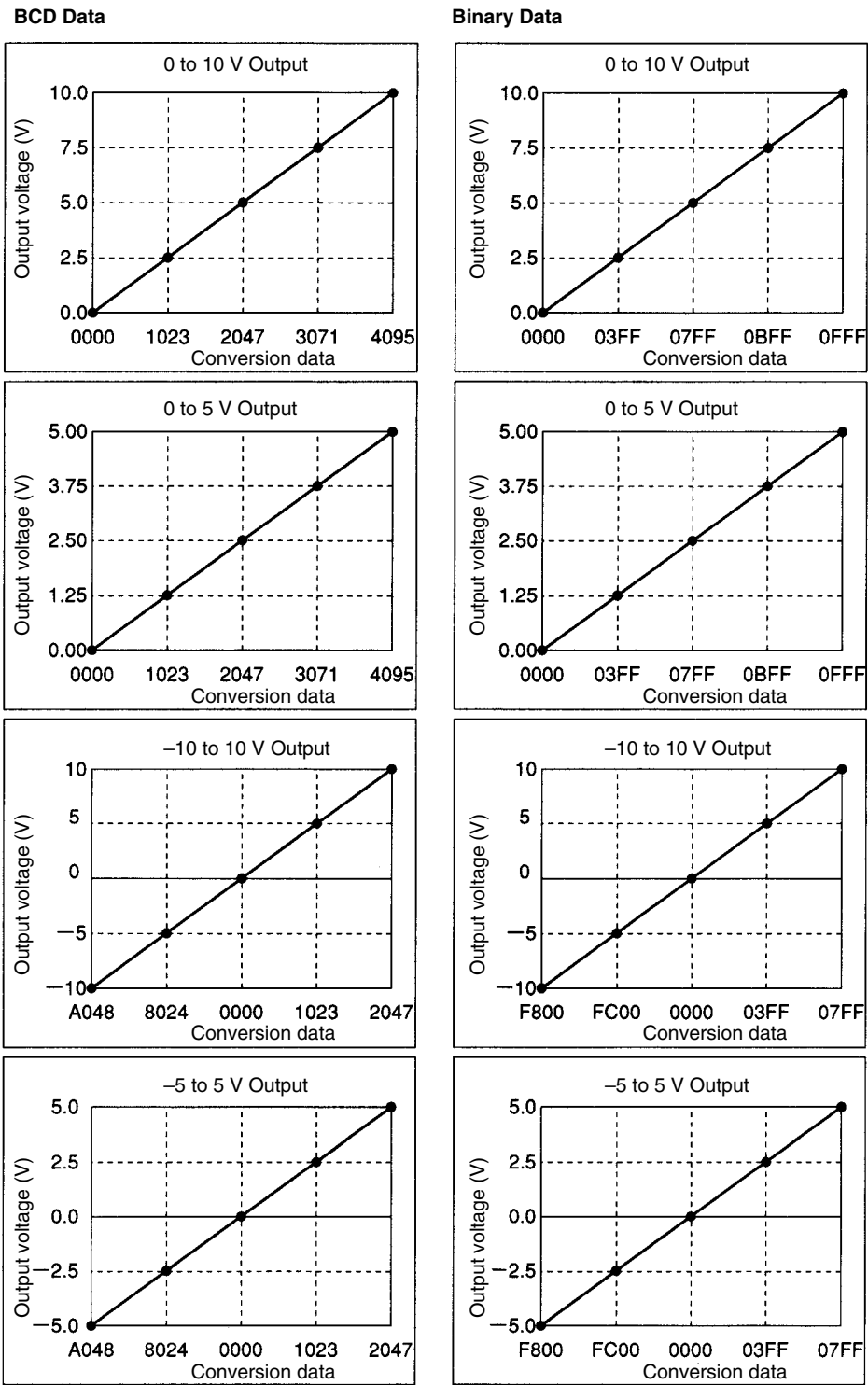

Current Outputs

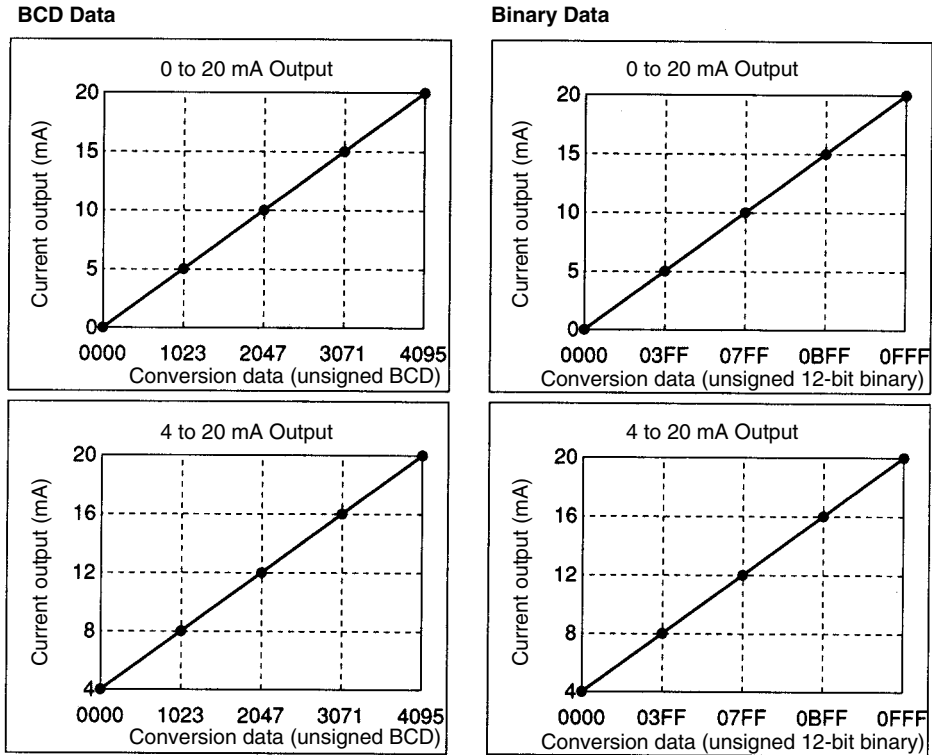

The output specifications of the C500-DA501 Analog Output Unit with scaling are shown below. Values between the scaling upper limit and lower limit are set as conversion data in engineering units.

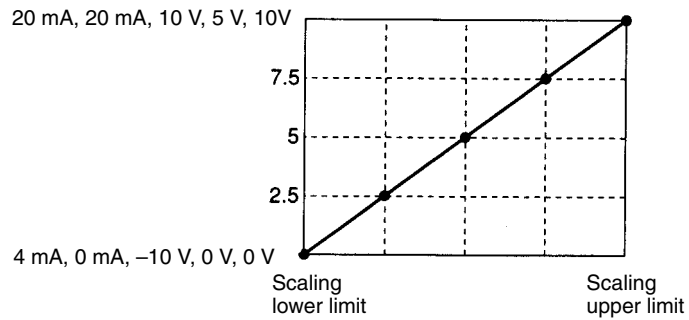

Conversion Data Limits (in BCD or Binary Mode)

Limits	BCD mode	Binary mode
Setting range between scaling upper limit and lower limit	-7999 to 7999 (F999 to 7999 _{Hex})	-32767 to 32767 (8001 to 7FFF _{Hex})

9-1-2 Overview

The C500-DA501 is a Special I/O Unit for the C500, C1000H, C2000H, CVM1, and CV-series PCs. It has eight analog output points and the following functions.

- Output signal range can be selected for each output point (0 to 10 V, 0 to 5 V, -5 to 5 V, -10 to 10 V, 0 to 20 mA, or 4 to 20 mA).
- Either BCD or binary format can be selected for the conversion data for each output point.
- Scaling can be set for each output point.
- Upper/lower limits can be set for each output point.
- An output ramp can be set for each output point.
- High-speed conversion can be set for all eight output points (only when scaling, upper/lower limits, and output ramps are not used).

Output Signal Range Selection

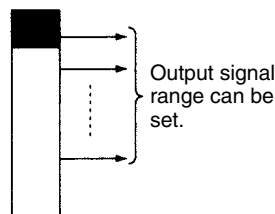

BCD/Binary Mode Selection

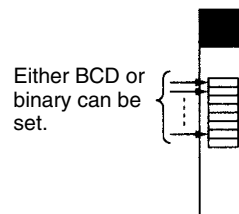

Scaling

Conversion data can be set in engineering units. The scaling upper and lower limits are set.

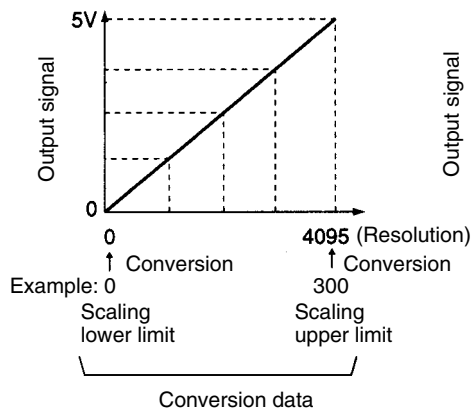

Upper/Lower Limits

Output signals remain constant when conversion data exceeds the upper limit or drops below the lower limit.

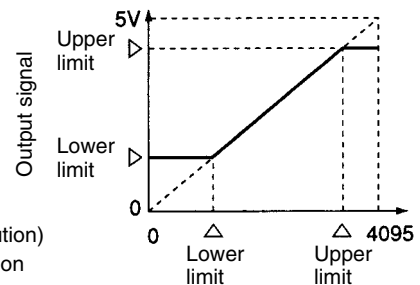

Note Reverse scaling (lower limit: 100%, upper limit: 0%) is also possible.

Output Ramps

Output ramps can be used to make output signals change at a specified rate to prevent sudden changes in response to changes in conversion data.

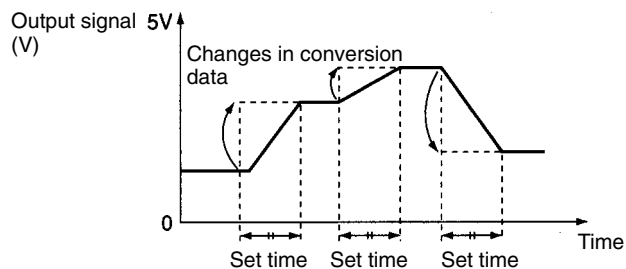

9-1-3 Description of Parts

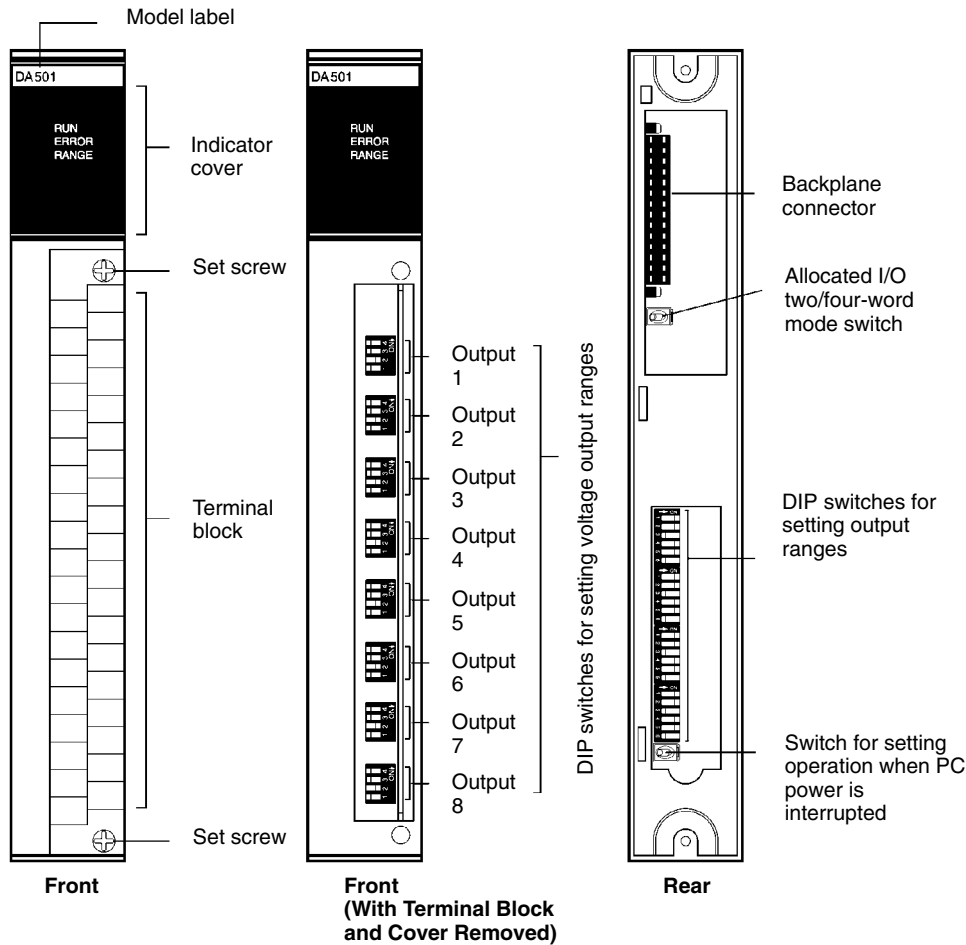

9-1-4 Indicators

Indicator	Color	Function
RUN	Green	Lit while the Unit is operating normally. Turns OFF when an error occurs. The Unit will stop operating. This indicator flashes when the total number of write operations to EEPROM reaches 5,000 or 10,000.
ERROR	Red	Lights or flashes in the following situations. Internal memory error. Incorrect data settings. Disconnected external 24 VDC power supply.
RANGE	Red	With Scaling Output signal range of 0 to 10 V, 0 to 5 V, 0 to 20 mA, or 4 to 20 mA: Lights when conversion data is smaller than 0 or greater than 4095, and turns OFF when conversion data is between 0 and 4095. Output signal range of -5 to 5 V or -10 to 10 V: Lights when conversion data is smaller than -2048 or greater than 2047, and turns OFF when conversion data is between -2048 and 2047. Without Scaling Lights when conversion data is smaller than the scaling lower limit or greater than the scaling upper limit, and turns OFF when conversion data is between the scaling lower limit and upper limit.

9-1-5 Block Diagram

The following diagram shows the basic internal connections of the Unit.

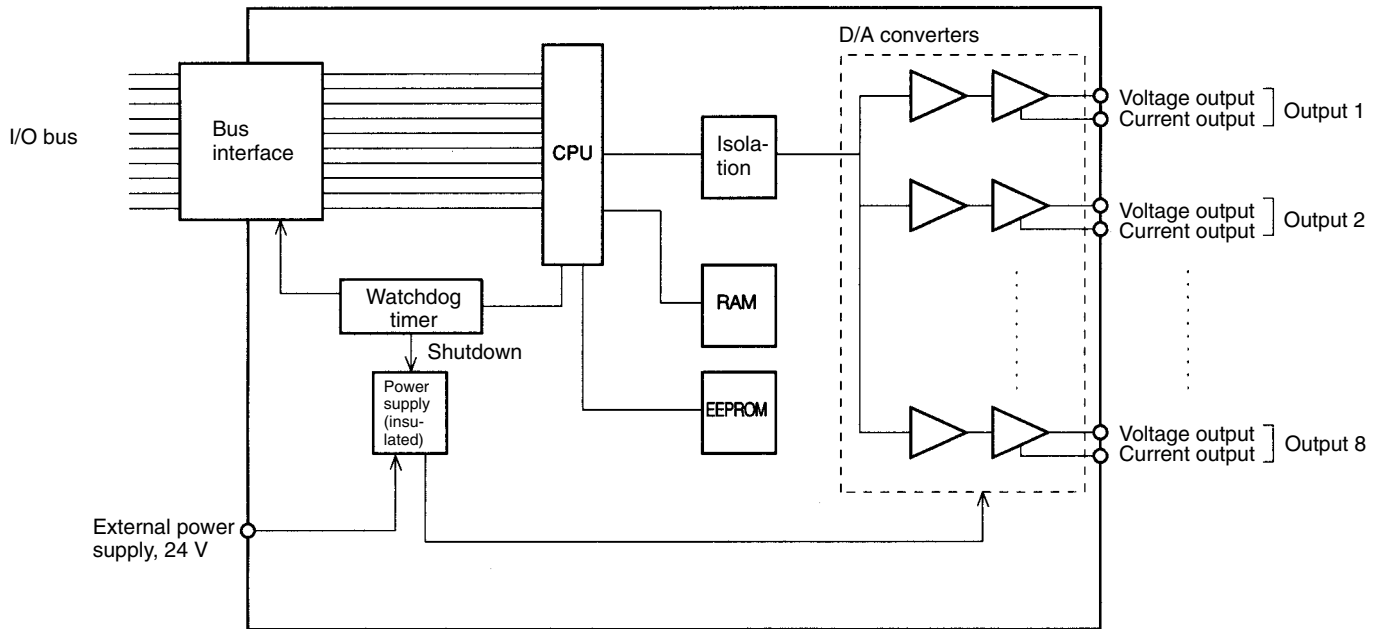

9-1-6 Internal Structure

The C500-DA501 Analog Output Unit has an internal 62-word Memory Map in RAM which contains conversion data, parameters, and status data. It is also allocated either 2 or 4 I/O words as a Special I/O Unit.

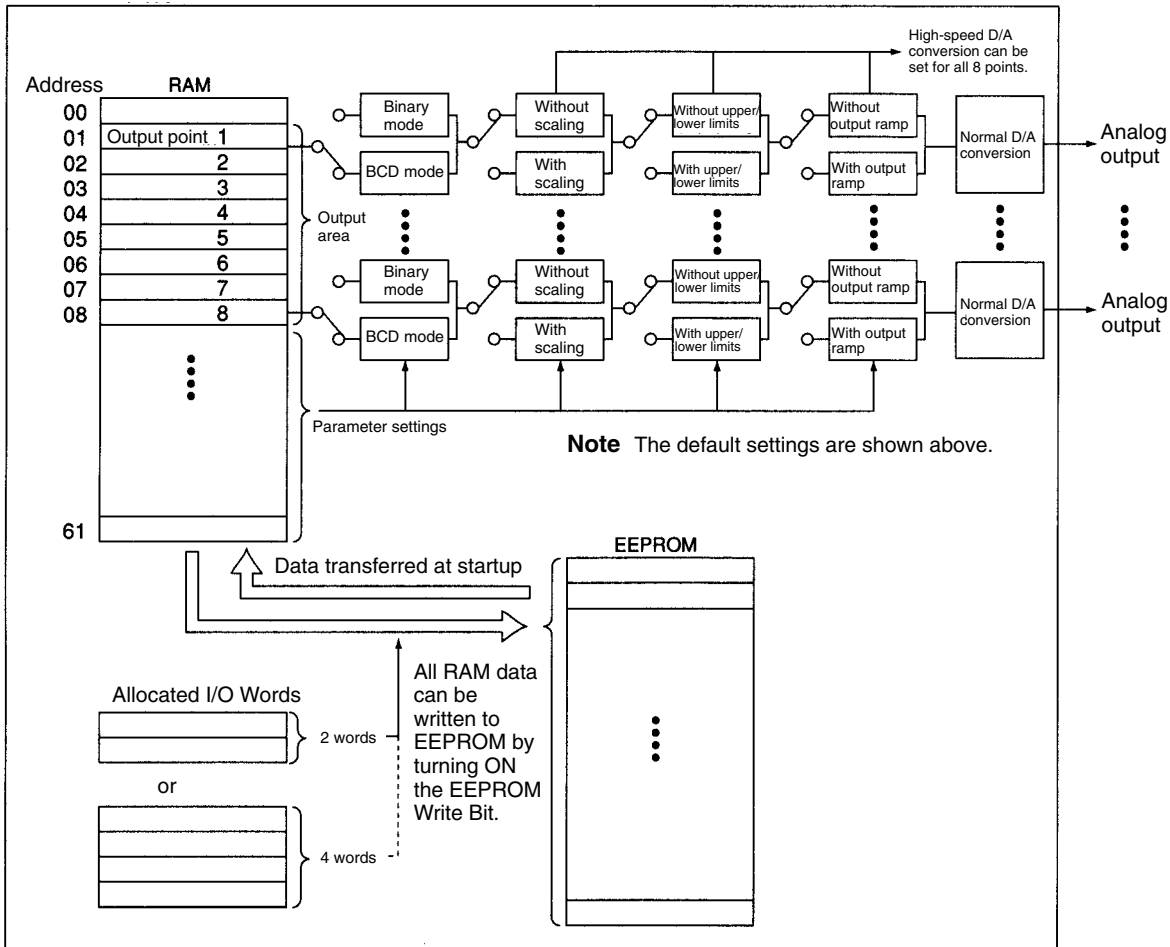

In two-word operating mode, the CPU Unit executes the I/O WRITE Instruction, WRIT, to directly set data in the output area with addresses 01 to 08 in RAM. In four-word operating mode, the CPU Unit executes a transfer instruction such as MOV to set data in the above output area through the allocated I/O words. When the scaling function is enabled, data in scaling-based engineering units (between the scaling lower and upper limits) is set in the output area.

Likewise, the CPU Unit sets data in each parameter area of RAM.

Note If parameter data is to be read from EEPROM at power-ON instead of transferring it from the ladder program each time, shift the EEPROM Write Flag from 0 to 1. All data will be automatically written from RAM to EEPROM when the power is turned ON.

Relationship with CPU Unit

When two words are allocated, the CPU Unit uses the I/O WRITE and I/O READ instructions, WRIT and READ, to directly access RAM. When four I/O words are allocated, the CPU Unit uses the MOV or OUT instruction to access RAM through the allocated I/O words.

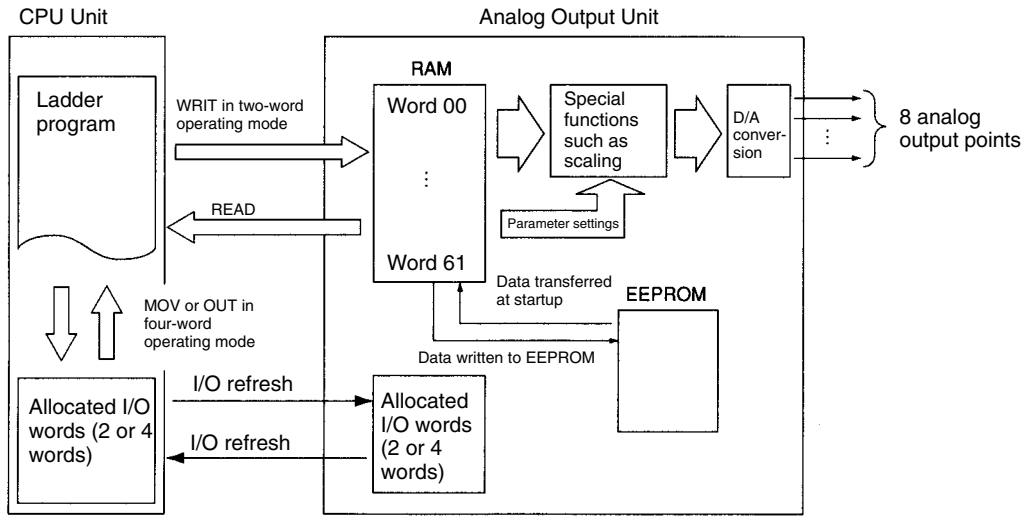

Memory Map

Memory Map in the Analog Output Unit consists of 62 words. It contains conversion data, status flags, and parameter setting data.

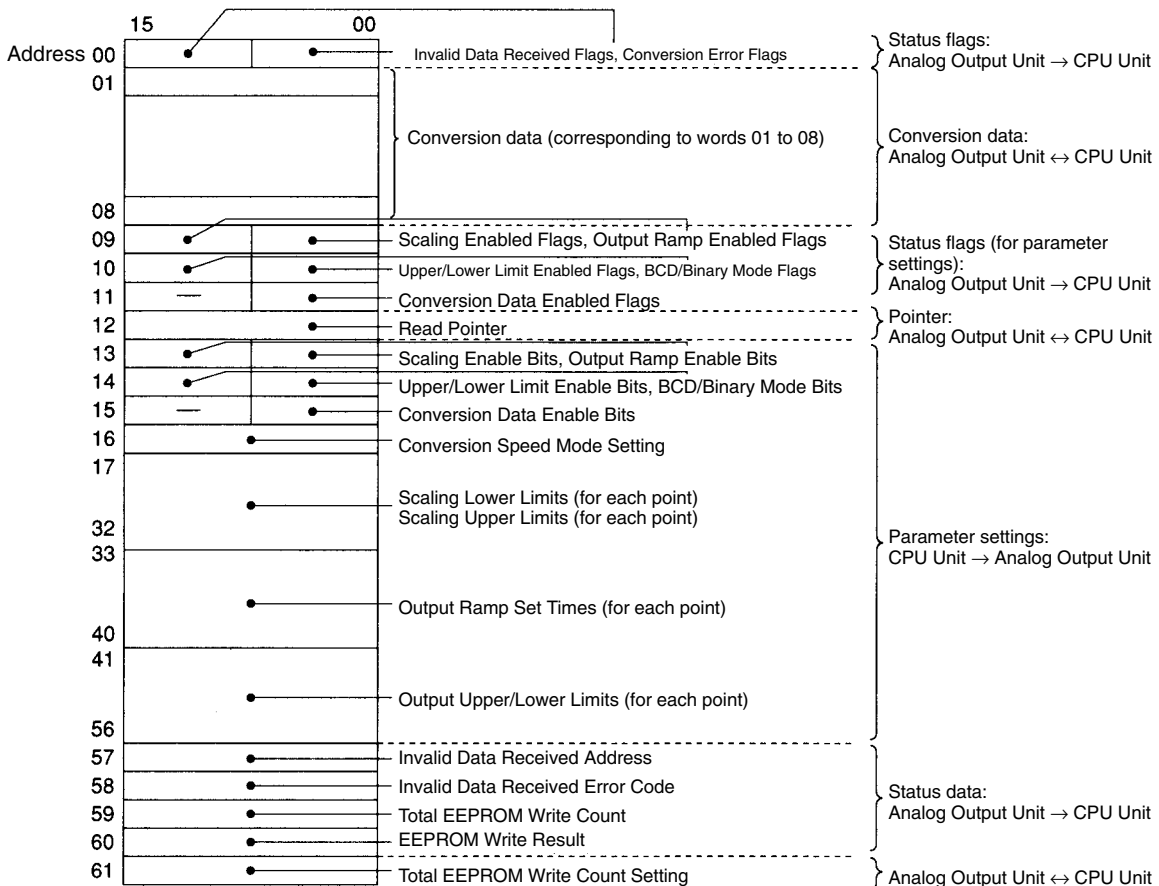

9-1-7 Operation Flow

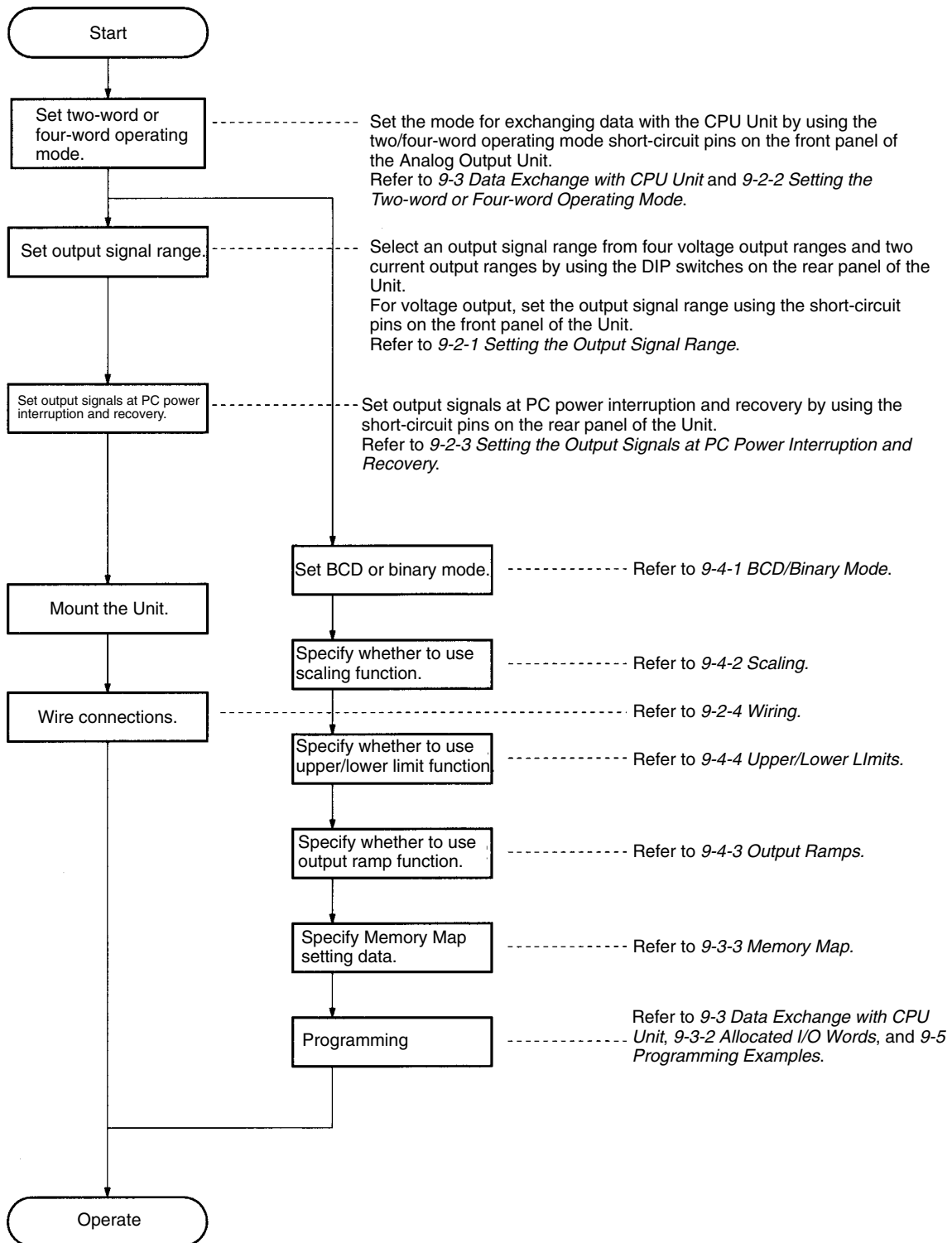

9-2 Settings and Wiring

9-2-1 Setting the Output Signal Ranges

The output signal ranges are set by using the DIP switches for output signal range settings and for voltage output range settings (for voltage outputs only).

Note Be sure to turn OFF the power to the PC before removing or mounting the terminal block or before changing the DIP switch settings.

DIP Switches for Setting Output Signal Ranges

There are four DIP switches on the back of the Unit with a total of 24 pins. As shown in the following diagram, they correspond in order from top to bottom to outputs 1 to 8. In the factory settings, all points are set to the 0 to 10 V range. Use an implement such as a ballpoint pen to set the DIP switch pins.

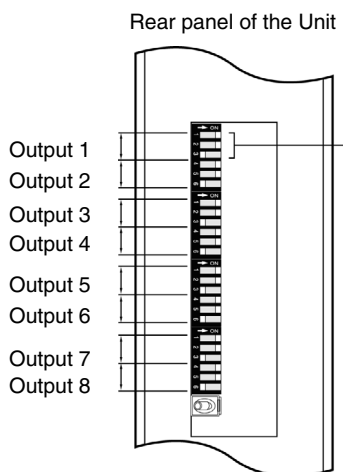

DIP switch pin No.	Output signal						Factory setting	
	Voltage output				Current output			
	0 to 10 V	0 to 5 V	-5 to 5 V	-10 to 10 V	0 to 20 mA	4 to 20 mA	0 to 10 V	
1	4	ON	ON	ON	ON	OFF	OFF	ON
2	5	ON	ON	OFF	OFF	ON	ON	ON
3	6	OFF	ON	ON	OFF	OFF	ON	OFF
DIP switches for setting voltage output ranges		Setting required (see note 1).				Setting not required (see note 1).		

- Note**
1. When a voltage output is set, it is also necessary to set the voltage output range DIP switch pins beneath the terminal block on the back of the Unit. Set the same voltage output range specifications on both DIP switches. Operation will not be correct if different specifications are set.
 2. When the output signal range is set to 4 to 20 mA or to 0 to 20 mA, the outputs will not be affected by the settings of the voltage output range DIP switch pins on the back of the Unit.
 3. The DIP switch settings are made valid when the PC is turned ON.

DIP Switches for Setting Voltage Output Ranges

When a voltage output is set, it is also necessary to set the voltage output range DIP switch pins under the terminal block on the back of the Unit to the same voltage output range.

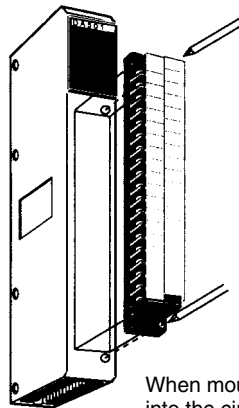

When mounting the terminal block, insert the connector correctly into the circuit board and then push the terminal block all the way in.

As shown in the following diagram, the DIP switches correspond in order from top to bottom to outputs 1 to 8. In the factory settings, all outputs are set to the 0 to 10 V range.

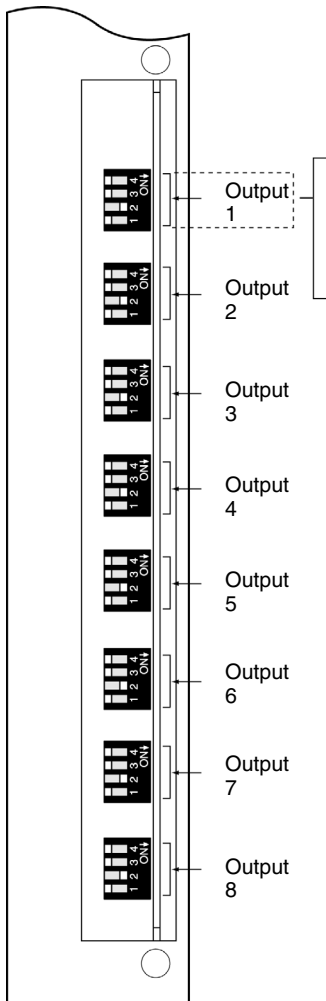

DIP switch pin No.	Voltage mode	ON	OFF	Factory setting
4	-10 to 10 V	Enabled	Disabled	OFF
3	-5 to 5 V	Enabled	Disabled	OFF
2	0 to 10 V	Enabled	Disabled	ON
1	0 to 5 V	Enabled	Disabled	OFF

- Note**
1. Outputs will not be correct if more than one DIP switch pin is turned ON. Turn ON only one of the pins shown above.
 2. When the output signal range is set to 4 to 20 mA or to 0 to 20 mA, the outputs will not be affected by the settings of these DIP switch pins.
 3. Voltage output range DIP switch settings are enabled when the power supply to the PC is turned ON.

Mounting the Terminal Block

When the output signal range has been set, mount the terminal block and tighten the upper and lower set screws.

Mounting the Unit

When mounting the Unit on the Backplane, make sure that the Unit is correctly inserted in the slot, then tighten the upper and lower mounting screws.

9-2-2 Setting the Two-word or Four-word Operating Mode

There is a toggle switch on the back of the Unit for selecting either two-word or four-word mode for the I/O allocations. The factory setting is for two-word mode.

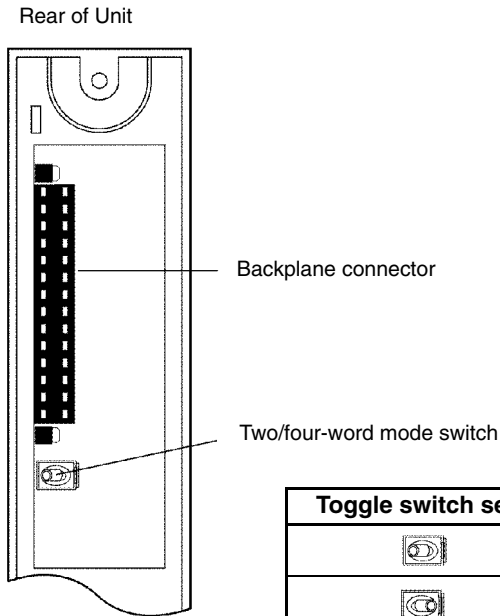

Toggle switch setting	Allocated I/O mode	Remarks
	Two-word mode	Factory setting
	Four-word mode	---

9-2-3 Setting the Output Signals at PC Power Interruption and Recovery

A toggle switch on the back of the Unit can be used to set the output signals from the Analog Output Unit when power to the PC (i.e., to the Power Supply Unit) is turned OFF. The factory setting is for 0 V or 0 mA whether power to the PC is OFF or ON.

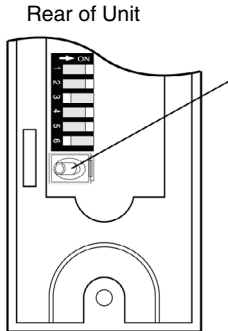

Switch for setting operation when PC power is turned OFF

Toggle switch setting	Output signal			Remarks
	When PC power is turned ON	When PC power is turned OFF	When 5 V power from Rack to Unit is turned OFF	
	0 V or 0 mA	0 V or 0 mA	0 V or 0 mA	Factory setting
	0 V or 0 mA	Output signal value at power interruption	0 V or 0 mA	See note.

Note With this setting, the output signal status is as shown in the following diagrams.

When power is turned OFF

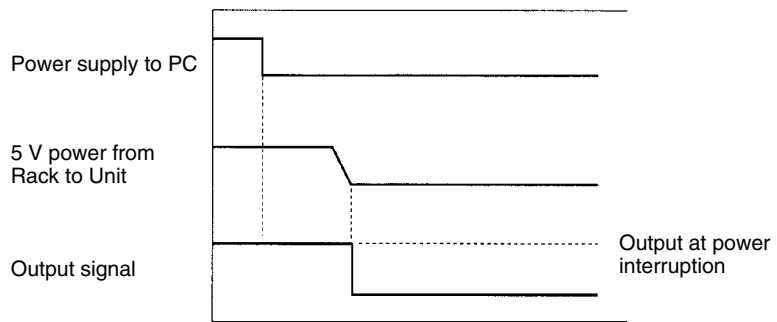

9-2-4 Wiring

The terminal arrangement is as shown in the following diagram.

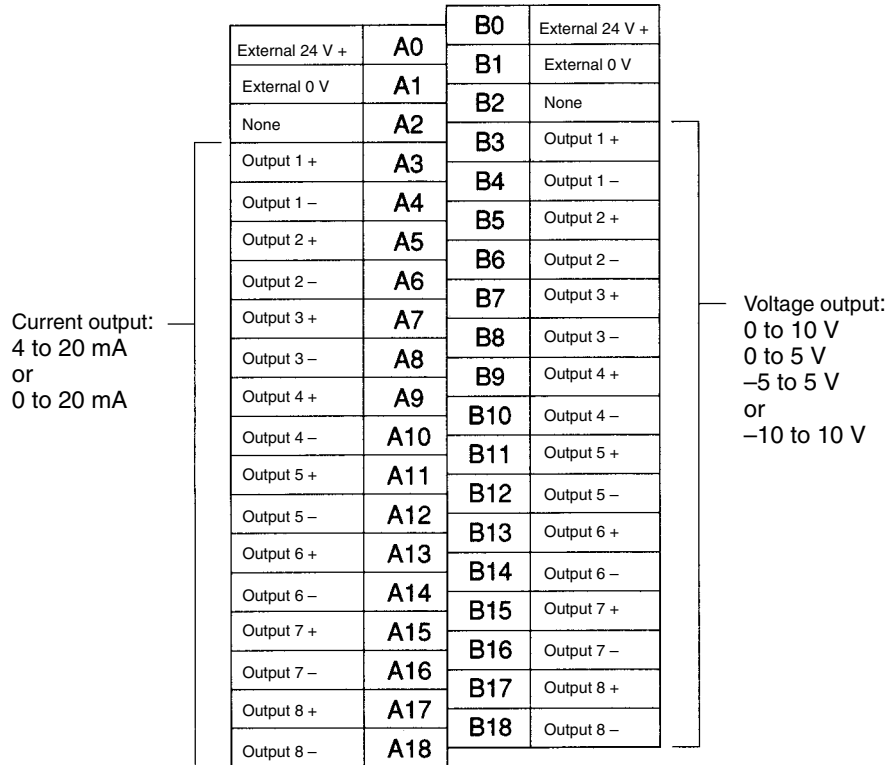

External Power Supply

This Analog Output Unit must receive an external power supply of 24 VDC $\pm 5\%$. The current consumption is 0.8 A.

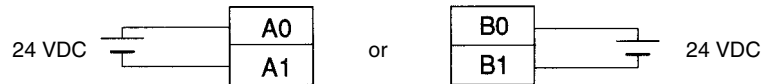

Note The external power supply to be used must meet the following specifications.

- Output voltage: 24 V
- Voltage adjustment range: $\pm 5\%$ min.
- Constant-voltage output accuracy: $\pm 3\%$ max.
- Output ripple: 400 mV_{p-p} max.
- Current capacity: 1 A min. per Unit

When using the external power supply, adjust the output voltage between A0 and A1 or between B0 and B1 to 24 ± 0.3 V.

Output Connections

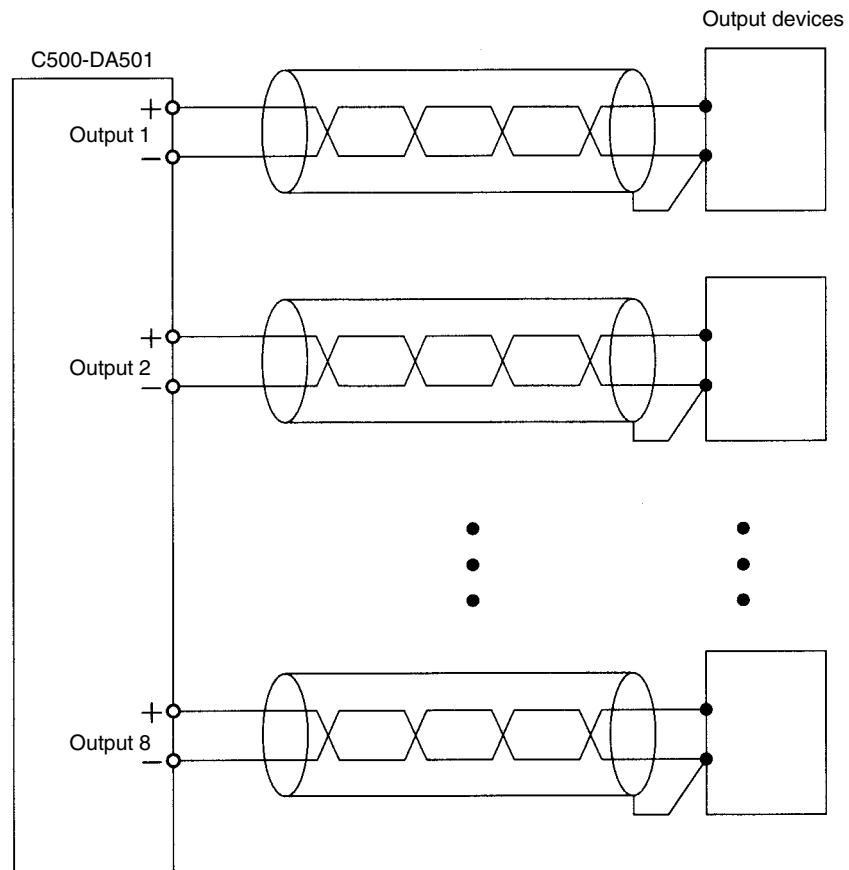

Precautions

Observe the following precautions when connecting cables to the Unit.

- Use shielded twisted pair cables as signal lines.
- Connect the shield to the output device. However, if doing so makes the negative terminal shared between the C500-DA501 and the output device and this fails to ensure insulation between output points, connect the shield to the C500-DA501.
- Use as short a cable as possible.
- The analog output signal cable contains a positive signal line and a negative signal line. Be careful to identify each signal line correctly.
- Do not route low-voltage cables, such as analog output signal cables, near high-voltage cables.
- Use wiring ducts to house cables. Use separate ducts for signal lines and power lines.
- Do not bend cables at acute angles.
- Do not route cables in places subject to vibration.

9-3 Data Exchange with CPU Unit

Overview

This section describes differences in data exchange with the CPU Unit between two-word and four-word operating modes. The two/four-word operating mode short-circuit pins on the front panel of the Unit are used to switch between two-word and four-word operating modes.

Two-word Operating Mode

The I/O READ and I/O WRITE instructions, READ and WRIT, are used to directly access RAM in the Analog Output Unit. More than one word can be read and written at a time. Data is exchanged when an instruction is executed.

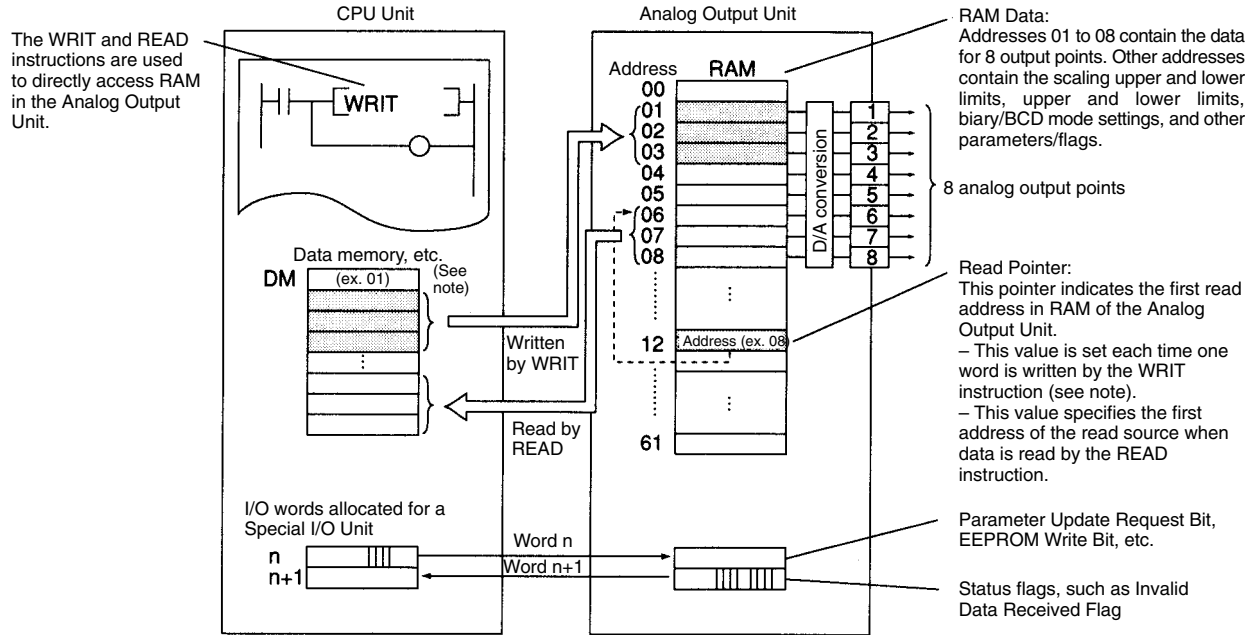

Note This value is not used when more than one word is written by the WRIT instruction. Instead, data in the first write word is used as the first RAM address.

Four-word Operating Mode

The MOV, OUT, and other generic instructions are used to read and write RAM data in the Analog Output Unit through the allocated I/O words. One word is read or written at a time. Data is exchanged at I/O refresh.

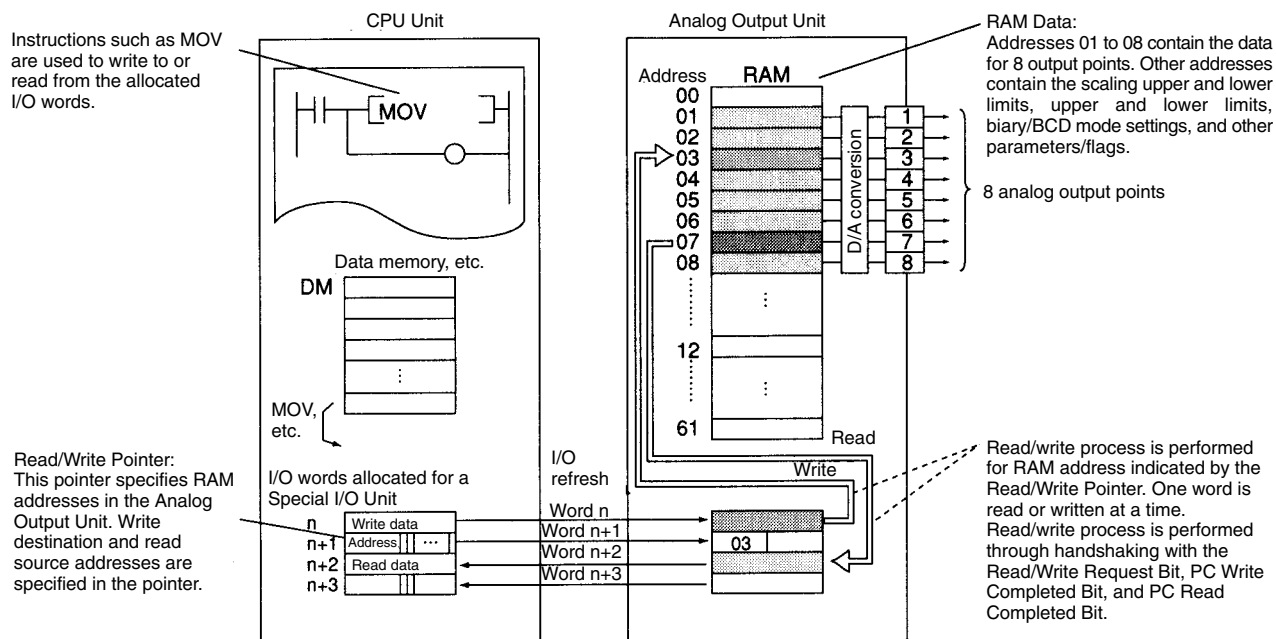

Comparison between Two-word and Four-word Operating Modes

Operating mode	Instructions available	Access to RAM	Data exchange	Word access	Restrictions
Two-word operation	I/O READ (READ) and I/O WRITE (WRIT)	Each time an instruction is executed. High-speed processing is possible.	63 words max.	Direct access	Cannot be used for Units on SYSMAC BUS Slave Racks.
Four-word operation	MOV, OUT, and other instructions	At the I/O refresh	One word at a time	Indirect access (via the allocated I/O words)	Can be used for Units on SYSMAC BUS Slave Racks.

9-3-1 Basic Operation

Two-word Operating Mode

- 1, 2, 3... 1. Use the I/O WRITE instruction, WRIT, to write parameters to the specified addresses in the Analog Output Unit.
2. After 100 ms (internal processing time required for the Analog Output Unit), use the WRIT instruction to write conversion data to addresses 02 to 08 in the Analog Output Unit.

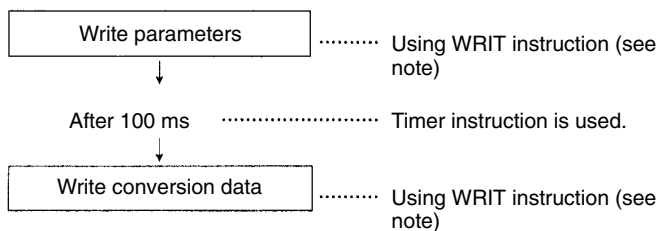

Note Specify a value greater than 1 as the number of words transferred in the WRIT instruction.

Using the I/O WRITE Instruction, WRIT

The function of the WRIT instruction depends on the number of words transferred (1 or more than 1) as described below. When writing parameters and conversion data directly to RAM in the Analog Operation Unit, set the number of words transferred to a value greater than 1.

When executing the WRITE instruction with the First Cycle Flag, there is a possibility that the Analog I/O Unit's internal processing may not be completed, and the WRITE instruction is not executed. When executing the WRITE instruction immediately after operation is started, use either of the following as the execution condition of the WRITE instruction:

- Bit 2 of word n+1 (A/D Write Completed Flag)
- A timer of at least 3 s.

All data written by the WRIT instruction is checked regardless of whether a function is enabled. If setting errors are detected, none of the data will be written. Therefore, only the data required for settings should be written individually.

If a series of data containing the settings of the functions not to be used is written, make settings so that the default values will be written as the settings for unused functions. This must be done before executing the WRIT instruction.

When the Number of Words Transferred is 1

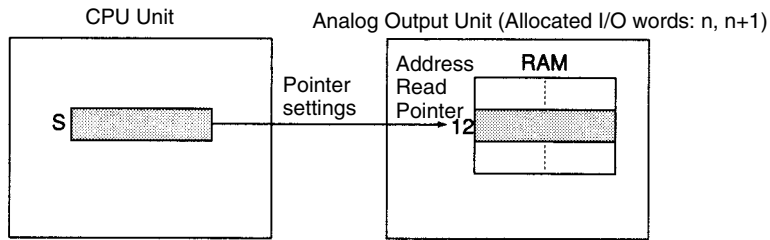
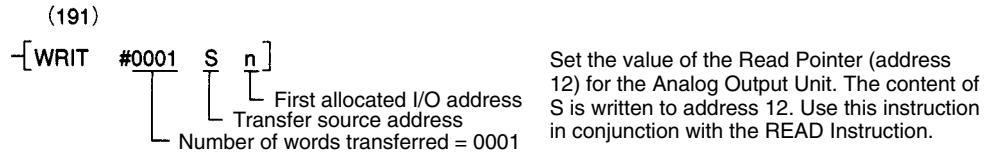

Example:

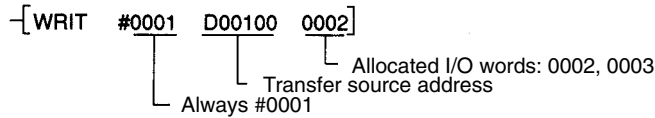

The content of D00100 is written to the Read Pointer (address 12).

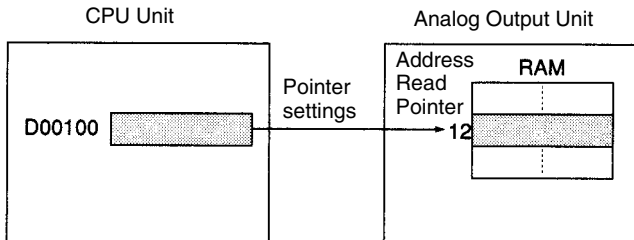

The I/O READ instruction, READ, uses the set value of the Read Pointer to read data from the specified number of words starting from the specified address in RAM.

The value of the Read Pointer remains valid until the next WRIT instruction is executed with the number of words transferred is turned ON, until the power is

turned OFF and then ON, or until the Unit is restarted. This value is turned OFF when the power is turned OFF and then ON or when the Unit is restarted.

When the Number of Words Transferred is Greater than 1

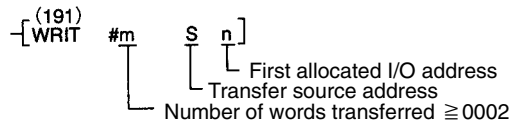

(m - 1) words starting from word S+1 are written by using the content of word S as the first RAM address of the Analog Output Unit. Use this instruction when writing parameters and conversion data directly to the Unit.

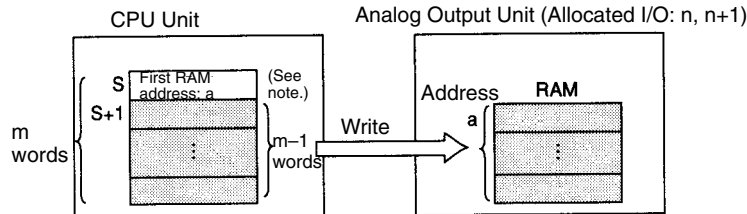

Note The specified first RAM address is not set in the Read Pointer (address 12) in RAM.

Example:

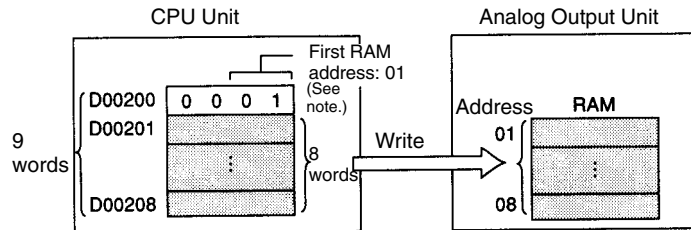
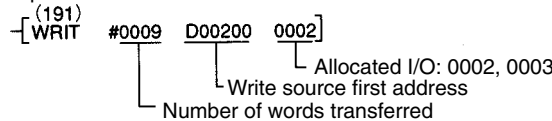

Using the I/O READ Instruction, READ

The READ instruction reads the specified number of words by using the content of the Read Pointer (address 12) in RAM of the Analog Output Unit as the first RAM address.

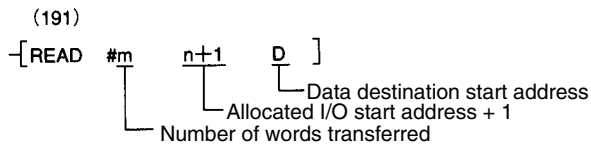

The READ instruction uses the value of the Read Pointer in RAM as the first RAM address to read data from m words and write it to words D to D+(m-1). Before executing the READ instruction, set the value of the Read Pointer in the WRIT instruction with the number of words transferred set to 1.

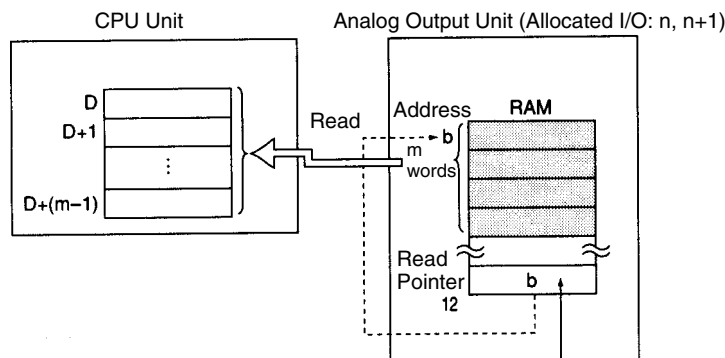

Set using the WRIT instruction with the number of words transferred set to 1.

Ladder Programming

Insert the WRIT instruction in a ladder program as follows:

- When the input conditions are met, a self-holding (latched) bit must be used to keep the execution condition ON until the WRIT instruction has been completed normally.
- While a WRIT instruction is being executed, a NC condition for the = Flag (which turns ON when the WRIT instruction has completed normally) must be used as an execution to prevent the next WRIT instruction from being executed.

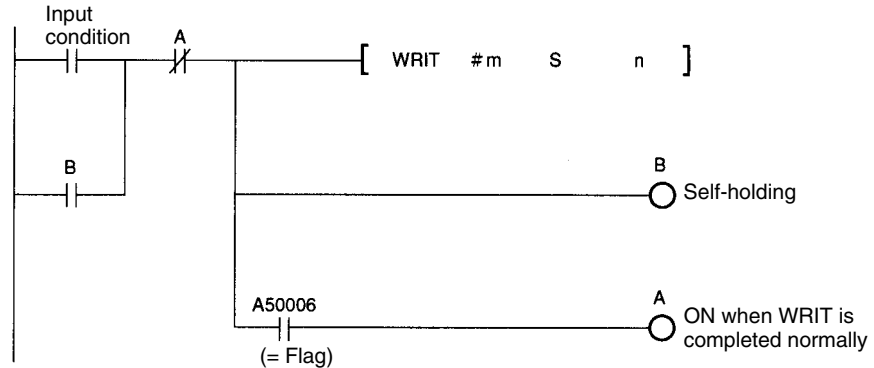
**READ/WRIT Execution Restrictions**

- 1, 2, 3... 1. The differentiated READ and WRIT instructions cannot be executed for Special I/O Units on SYSMAC BUS/2 Slave Racks. The READ and WRIT instructions must be executed until the = Flag (A50006) turns ON indicating that the execution is completed.
2. The READ and WRIT instructions cannot be simultaneously executed for the same Special I/O Unit. In such cases, execute WRIT first, and after the execution is completed, execute READ.
3. One SYSMAC BUS/2 Remote I/O Master Unit can simultaneously handle up to two READ and WRIT instructions. If two READ and WRIT instructions are executed for Units mounted to SYSMAC BUS/2 Slave Racks and an attempt is made to execute a READ or WRIT instruction for a third Unit, the CY Flag (A50004) will be turned ON without executing the third instruction.
4. Therefore, when continuously executing READ instructions, you can use the READ and WRIT instructions for a maximum of two Special I/O Units under each SYSMAC BUS/2 Remote I/O Master Unit.
5. Up to four SYSMAC BUS/2 Remote I/O Master Units can be mounted to the CV1000 or CV2000. In this case, therefore, up to eight READ and WRIT instructions can be executed simultaneously.
6. Up to 255 words can be transferred using a READ or WRIT instruction.

If the program writes conversion data after parameters, design the program as follows: Even if an attempt is made to write conversion data immediately after parameters, such as scaling upper and lower limits, upper and lower limits, and binary/BCD mode settings, are written, the data may not be correctly written due to the internal processing of the Analog Output Unit. For this reason, design the program so that it writes conversion data at least 100 ms after parameters have been written. Also, the Parameter Update Bit must be turned ON to make the written parameters valid.

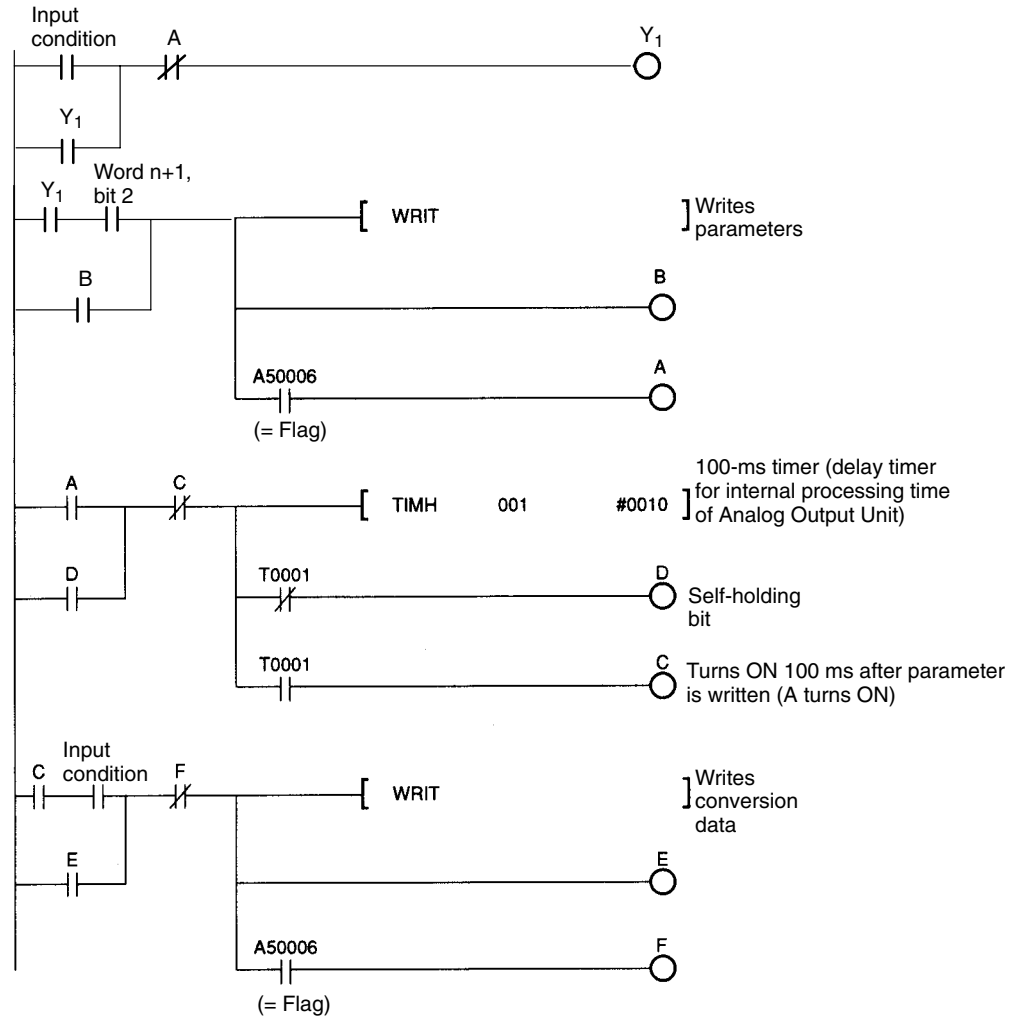

If write data, such as the first RAM addresses, parameters, and conversion data, is to be set in the data memory immediately before the WRIT instruction is executed, design the program as shown in the following diagram.

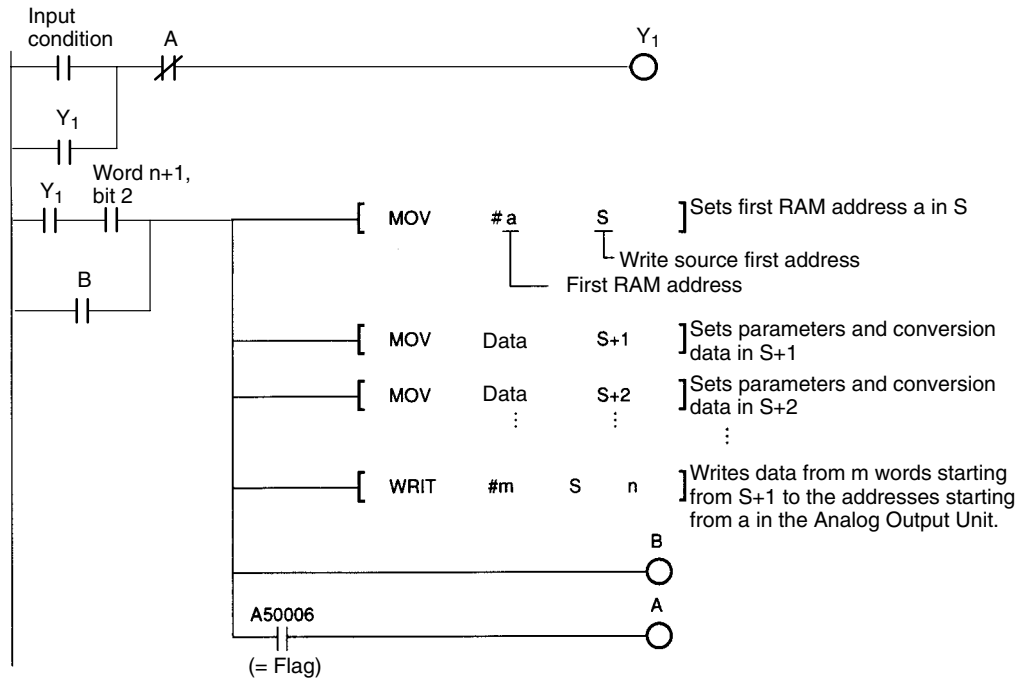

Four-word Operating Mode

Writing Data

- 1, 2, 3... 1. The CPU Unit uses MOV or another similar instruction to set data in word n of the allocated I/O words.
2. The CPU Unit sets RAM address of the Analog Output Unit in the leftmost byte of word n+1 (bits 08 to 15: Read/Write Pointer).
3. The CPU Unit sets bit 00 of word n+1 (Read/Write Request Bit: OFF for read, ON for write) to 1.
4. The CPU Unit turns ON bit 06 of word n+1 (PC Write Completed Bit).
5. The Analog Output Unit reads data from word n of the allocated I/O words to the specified RAM address.
6. When the Analog Output Unit reads the data, bit 06 of word n+3 (Analog Output Unit Read Completed Flag) in the allocated I/O words is turned ON.
7. The CPU Unit verifies that bit 06 of word n+3 is turned ON, then turns OFF bit 06 of word n+1 (PC Write Completed Bit).
8. When bit 06 of word n+1 turns OFF, bit 06 of word n+3 (Analog Output Unit Read Completed Flag) turns OFF again.

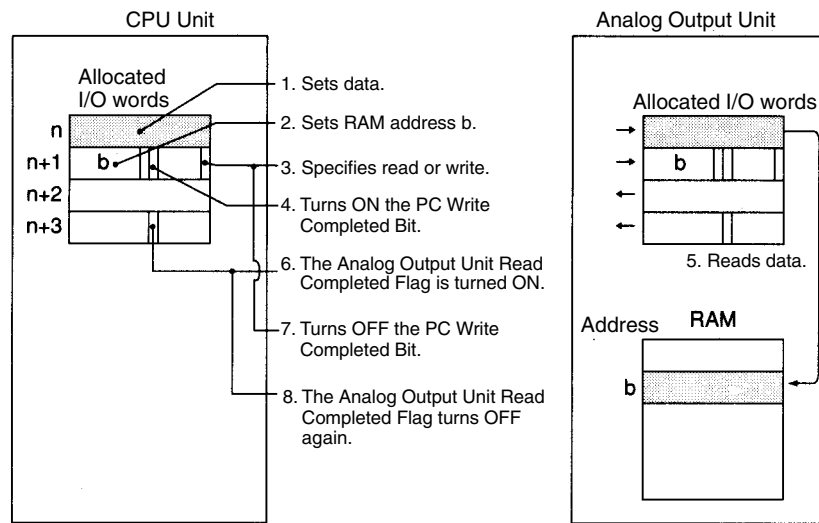

Timing Chart

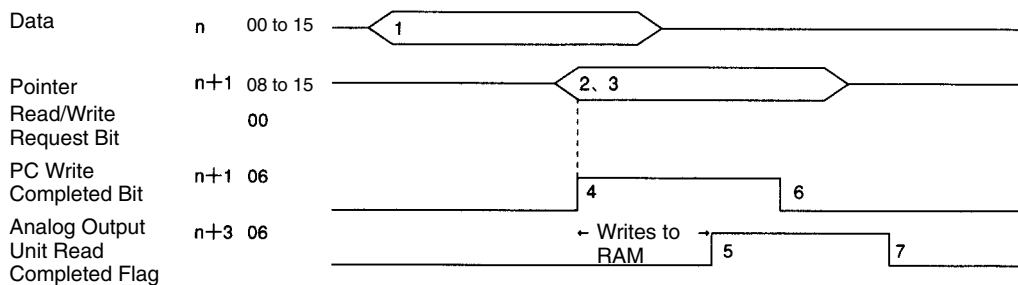

Ladder Programming

An example of data write processing and write completion monitoring programs is shown below.

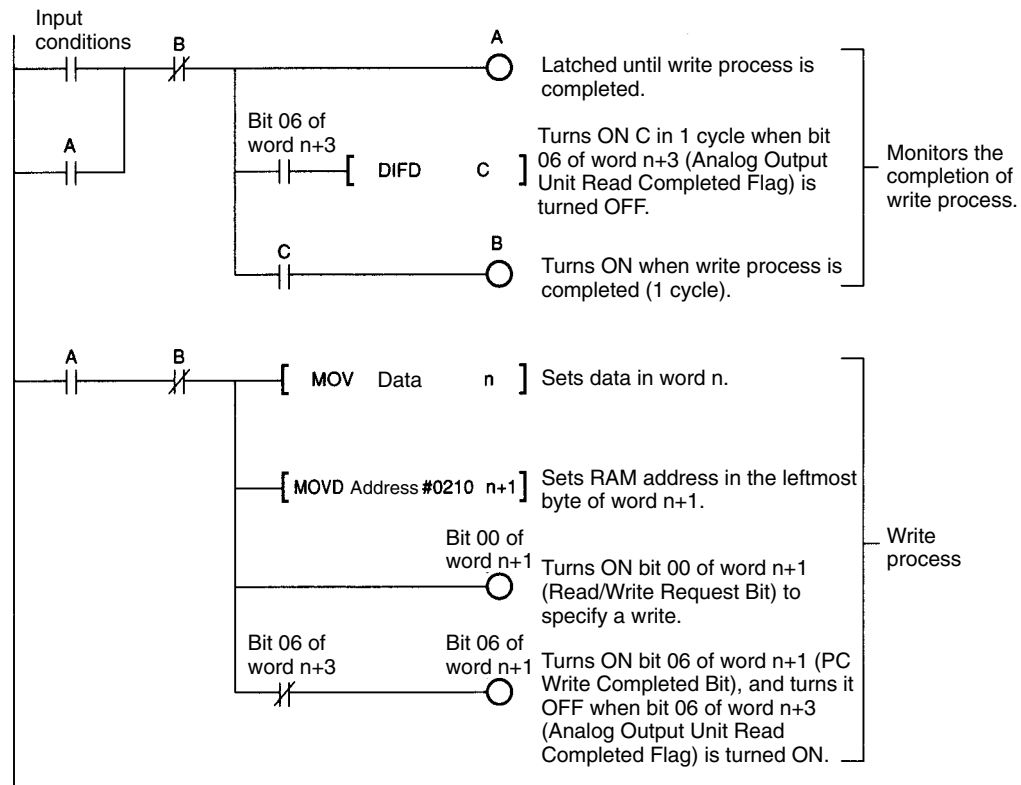
**Reading Data**

- 1, 2, 3...
 1. The CPU Unit sets RAM address of the Analog Output Unit in the leftmost byte of word n+1 (bits 08 to 15: Read/Write Pointer) in the allocated I/O words.
 2. The CPU Unit turns OFF bit 00 of word n+1 (Read/Write Request Bit: OFF for read, ON for write).
 3. The CPU Unit turns ON bit 06 of word n+1 (PC Write Completed Bit) to notify the Analog Output Unit that RAM address has been set.
 4. When the Analog Output Unit reads RAM address, bit 06 of word n+3 (Analog Output Unit Read Completed Flag) is turned ON.
 5. The CPU Unit verifies that bit 06 of word n+3 is turned ON, then turns OFF bit 06 of word n+1 (PC Write Completed Bit).
 6. When bit 06 of word n+1 is turned OFF, bit 06 of word n+3 (Analog Output Unit Read Completed Flag) turns OFF again.
 7. When the Analog Output Unit reads data from the specified address and sets it in word n+2, bit 07 of word n+3 (Analog Output Unit Write Completed Flag) is turned ON.
 8. The CPU Unit verifies that bit 07 of word n+3 is ON, then reads data from word n+2. At the same time, it turns ON bit 07 of word n+1 (PC Read Completed Bit).
 9. When bit 07 of word n+1 is turned ON, bit 07 of word n+3 (Analog Output Unit Write Completed Flag) turns OFF again.

10. The CPU Unit verifies that bit 07 of word n+3 is OFF, then turns OFF bit 07 of word n+1 (PC Read Completed Bit).

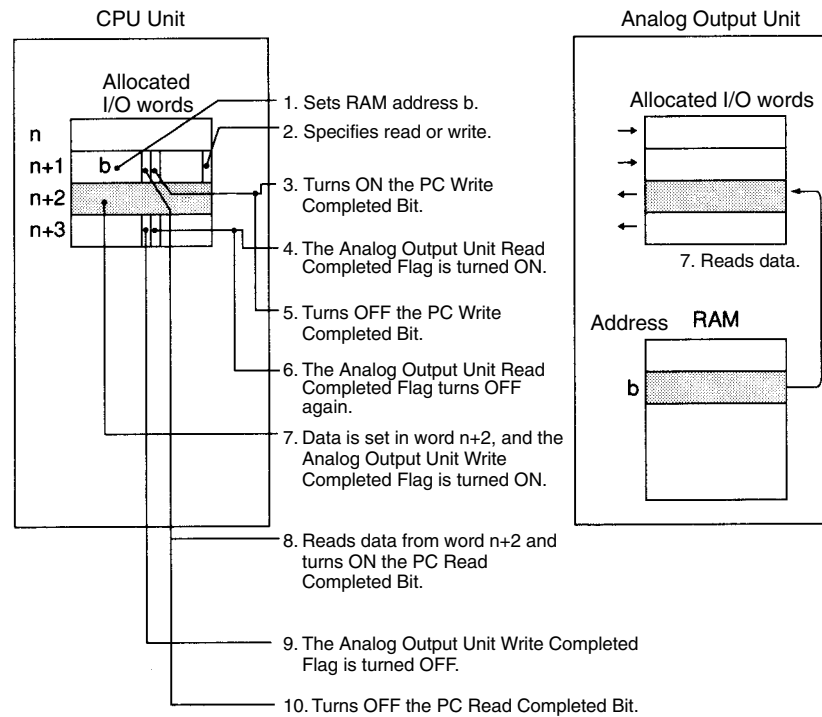

Timing Chart

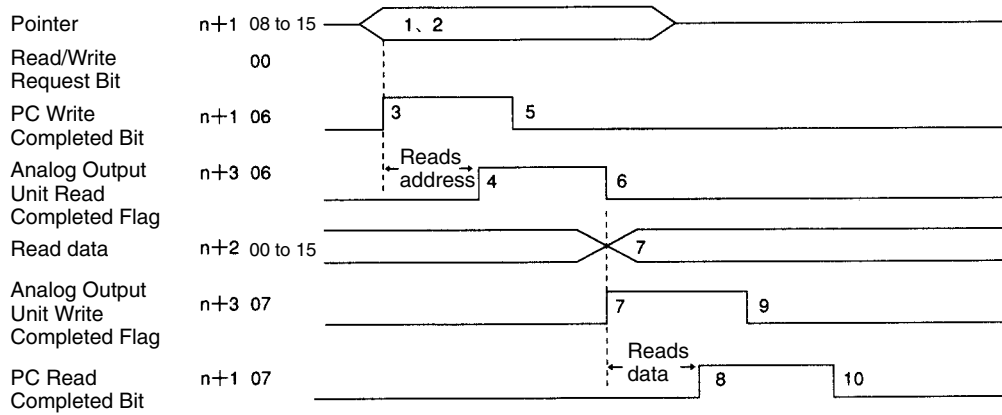

9-3-2 IR/CIO Bit Allocations

Two-word Operating Mode

Output Words (CPU Unit → Analog Output Unit)

Allocated I/O word	Bit	Name	Function
n	0	PC Busy	These bits operate automatically when executing I/O READ/WRITE instructions. It is not possible for the user to write to these bits. Set to 0 when outputting word n using an output instruction, such as the MOV instruction.
	1	PC Write Complete	
	2	PC Read Complete	
	3	EEPROM Write Bit	When this bit is turned ON, the content of RAM is written to EEPROM. The data is automatically read from EEPROM back to RAM when the power is turned ON.
	4	Reserved	---
	5	Parameter Update Bit	When this bit is turned ON, the last set parameters such as the scaling function, output ramp function, upper/lower limit function, and binary/BCD mode are made valid. Due to the internal processing time of the Analog Output Unit, turn ON this bit at least 100 ms after the parameters have been written.
	6	Reserved	---
	7	Reserved	---
	8	Reserved	---
	9	Reserved	---
	10	Reserved	---
	11	Reserved	---
	12	Reserved	---
	13	Reserved	---
	14	Reserved	---
	15	Reserved	---

Input Words (Analog Output Unit → CPU Unit)

Allocated I/O word	Bit	Name	Function
n+1	0	D/A Busy	These bits operate automatically when executing I/O READ/WRITE instructions.
	1	D/A Read Complete	
	2	D/A Write Complete	
	3	Invalid Data Received Flag	This flag is turned ON when invalid data is received from the I/O WRITE instruction, WRIT. The Analog Output Unit will return to the original configuration and ignore all data containing errors. This flag is turned OFF when valid data is written.
	4	Conversion Error Flag	This flag is turned ON when a conversion error is detected in the Analog Output Unit. The Analog Output Unit will return to the original configuration and ignore all data containing errors. This flag is turned OFF when valid data is written.
	5	Conversion Speed Mode Flag	This flag is used to select either of the following conversion speed modes. OFF: Normal ON: High-speed
	6	Reserved	---
	7	Reserved	---
	8	Upper/Lower Limit Over Flag	This flag is turned ON when conversion data exceeds the upper limit or drops below the lower limit. It is cleared when conversion data between the upper and lower limits is written.
	9	External Power Supply ON Flag	This flag is turned ON when external power supply is turned ON.
	10	Reserved	---
	11	Pulse Signal Flag	The Analog Output Unit generates ON-OFF signals with a frequency of 1 Hz and a load cycle of 50% (ON for 0.5 second, OFF for 0.5 second) during normal operation. It temporarily stops outputting pulse signals while data is being written to EEPROM, and restarts outputting signals when the write operation has been completed.
	12	Analog Output Unit OK Flag	This flag is turned ON when the internal diagnostic function ends normally. It is turned OFF when an internal error has been detected. If turning the power OFF and then ON does not turn OFF this flag, replace the Unit.
	13	Reserved	---
	14	Reserved	---
15	Reserved	---	

Four-word Operating Mode**Output Words (CPU Unit → Analog Output Unit)**

Allocated I/O word	Bit	Name	Function
n	00 to 15	Write Data	This data is automatically written to RAM addresses specified by the Read/Write Pointer (bits 08 to 15 of word n+1) while a write cycle is being performed for the Analog Output Unit.
n+1	00	Read/Write Request Bit	This bit specifies whether access to the Analog Output Unit is a read request (OFF) or a write request (ON). When a read request is specified, data in RAM addresses specified by the Read/Write Pointer (bits 08 to 15 of word n+1) is read and stored as read data in word n+2. When a write request is specified, write data in word n is written to RAM addresses specified by the Read/Write Pointer (bits 08 to 15 of word n+1).
	01	Reserved	---
	02	Reserved	---
	03	EEPROM Write Bit	When this bit is turned ON, data is transferred from RAM to EEPROM. Due to the internal processing time of the Analog Output Unit, turn ON this bit at least 100 ms between each write operation.
	04	Reserved	---
	05	Parameter Update Bit	When this bit is turned ON, the last set parameters, such as the scaling function, output ramp function, upper/lower limit function, and binary/BCD mode, are made valid. Due to the internal processing time of the Analog Output Unit, turn ON this bit at least 100 ms after the parameters have been written.
	06	PC Write Completed Bit	This bit is turned ON in the CPU Unit to notify the Analog Output Unit that there is new data in words n and n+1. After verifying that the Analog Output Unit Read Completed Flag (bit 06 of word n+3) is ON, the CPU Unit turns OFF this bit. When this bit is turned OFF, the Analog Output Unit Read Completed Flag turns OFF again. If an attempt is made to write data without turning ON this bit, it will be ignored.
	07	PC Read Completed Bit	This bit is turned ON in the CPU Unit to notify the Analog Output Unit that data has been read from words n+2 and n+3. When this bit is turned ON, the Analog Output Unit Write Completed Flag (bit 07 of word n+3) turns OFF again. After verifying that the Analog Output Unit Write Completed flag is turned OFF, the CPU Unit turns OFF this bit.
	08 to 15	Read/Write Pointer	This pointer specifies a RAM address. BCD values between 00 and 61 are valid.
15	Reserved	---	

Input Words (Analog Output Unit → CPU Unit)

Allocated I/O word	Bit	Name	Function
n+2	00 to 15	Read Data	This data is automatically read from RAM addresses specified by the Read/Write Pointer (bits 08 to 15 of word n+1) when a read cycle is performed for the Analog Output Unit.
n+3	00 to 02	Reserved	---
	03	Invalid Data Received Flag	This flag is turned ON when invalid data is sent to the Analog Output Unit. The Analog Output Unit will return to the original configuration and ignore all data containing errors. This flag is turned OFF when valid data is written.
	04	Conversion Error Flag	This flag is turned ON when a conversion error is detected in the Analog Output Unit. The Analog Output Unit will return to the original configuration and ignore all data containing errors. This flag is turned OFF when valid data is written.
	05	Conversion Speed Mode Flag	This flag is used to select either of the following conversion speed modes. ON: Normal OFF: High-speed
	06	Analog Output Unit Read Completed Flag	This flag is turned ON when the Analog Output Unit reads data from words n and n+1. The Analog Output Unit uses this flag to notify the CPU Unit that data has been read from words n and n+1.
	07	Analog Output Unit Write Completed Flag	This flag is turned ON when the Analog Output Unit writes data to word n+2. The Analog Output Unit uses this flag to notify the CPU Unit that data has been written to word n+2.
	08	Upper/Lower Limit Over Flag	This flag is turned ON when conversion data exceeds the upper limit or drops below the lower limit. It is turned OFF when conversion data between the upper and lower limits is written.
	09	External Power Supply ON Flag	This flag is turned ON when external power supply is turned ON.
	10	Data Transfer Sequence Error Flag	This flag indicates a transfer protocol error. It is turned ON when the data transfer sequence ends abnormally. This flag is turned OFF by setting or resetting the PC Read Completed Bit (bit 07 of word n+1). All read and write operations are ignored until this flag is turned OFF.
	11	Pulse Signal Flag	The Analog Output Unit generates ON-OFF signals with a frequency of 1 Hz and a load cycle of 50% (ON for 0.5 second, OFF for 0.5 second) during normal operation. It temporarily stops outputting pulse signals while data is being written to EEPROM, and restarts outputting signals when the write operation is completed.
	12	Analog Output Unit OK Flag	This flag is turned ON when the internal diagnostic function ends normally. It is turned OFF when an internal error is detected. If turning the power OFF and then ON does not turn OFF this flag, replace the Unit.
	13	Reserved	---
14	Reserved	---	
15	Reserved	---	

9-3-3 Memory Map

The Analog Output Unit has a 62-word RAM which contains 16-bit data, 1-bit control bits, and 1-bit flags.

RAM contains data in BCD or binary format. Use the BCD/Binary Mode Bit to specify the data format (BCD or binary) for each output point. By default, all output points are set to BCD format. All data for each point will be in the same format (BCD or binary).

The sign (signed/unsigned) and range of data in BCD or binary format depend on the data format in RAM, as shown in the following table.

Data format	Decimal notation	Format in RAM	Data format			
			Conversion data, upper and lower limits			Output ramp set time
			Without scaling		With scaling	
			0 to 10 V 0 to 5 V 0 to 20 mA 4 to 20 mA	-5 to 5 V -10 to 10 V		
Sign			Unsigned	Signed	Signed	Unsigned
BCD	-7999	F999 (see note)	Not possible.	Not possible.	OK	Not possible.
	-2048	A048 (see note)	Not possible.	OK	OK	Not possible.
	-1	8001 (see note)	Not possible.	OK	OK	Not possible.
	0	0000	OK	OK	OK	OK
	2047	2047	OK	OK	OK	OK
	4095	4095	OK	Not possible.	OK	OK
	7999	7999	Not possible.	Not possible.	OK	OK
Binary	-32767	8001	Not possible.	Not possible.	OK	Not possible.
	-2048	F800	Not possible.	Not possible.	OK	Not possible.
	-1	FFFF	Not possible.	OK	OK	Not possible.
	0	0000	OK	OK	OK	OK
	2047	07FF	OK	OK	OK	OK
	4095	0FFF	OK	Not possible.	OK	OK
	32767	7FFF	Not possible.	Not possible.	OK	OK

Note Bit 15 is the sign bit.

Control Bits and Flags

In addition to data, RAM contains control bits and flags.

Control bits	Set in the CPU Unit to execute a specific function.
Flag	Set by the Analog Output Unit to notify the CPU Unit of status. OFF: Disabled or OFF ON: Enabled or ON

Both control bits and flags are arranged in the following format. Bits 0 to 7 and 8 to 15 correspond to output points 1 to 8.

Bit number	15	14	13	12	11	10	09	08	07	06	05	04	03	02	01	00
Output	8	7	6	5	4	3	2	1	8	7	6	5	4	3	2	1

Memory Map Contents

Words	Bits	Output points	Name	Description	Data	Default	Read: R Write: W
00	0 to 7	1 to 8	Invalid Data Received Flags	Turned ON by the Analog Output Unit when invalid data is written to an output point in RAM. Turned OFF when valid data is written to the same part of RAM. When this error occurs, bit 3 of word n+1 (bit 3 of word n+3) in the allocated I/O words is also turned ON.	ON: Error OFF: Normal	0	R
	8 to 15	1 to 8	Conversion Error Flags	Turned ON when a conversion error is detected in the Analog Output Unit. When this error occurs, bit 4 of word n+1 (bit 4 of word n+3) in the allocated I/O words is also turned ON.	ON: Error OFF: Normal	0	R
01 to 08	0 to 15	1 to 8	Conversion Data	Conversion source data for each output signal. conversion data can be in either BCD or binary (set in bits 8 to 15 of address 14 in RAM). If the scaling function is disabled, conversion data is taken immediately before conversion. If the scaling function is enabled, conversion data is in engineering units. (This data is scaled and then subject to conversion.) If the upper/lower limit function is enabled, the upper and lower limits are written whenever values above the upper limit or below the lower limit are set.	With No Scaling BCD: 0 to 4095 (0000 to 4095 _{Hex}) or -2048 to 2048 (A048 to 2048 _{Hex}) Binary: 0000 to 0FFF _{Hex} or F800 to 07FF _{Hex} With Scaling BCD: -7999 to 7999 (F999 to 7999 _{Hex}) Binary: -32767 to 32767 (8001 to 7FFF _{Hex})	0000 _{Hex}	R/W
09	0 to 7	1 to 8	Scaling Enabled Flags	Turned ON by the Analog Output Unit to indicate status of scaling specified in bits 00 to 07 of word 13.	ON: Enabled OFF: Disabled	0	R
	8 to 15	1 to 8	Output Ramp Enabled Flags	Turned ON by the Analog Output Unit to indicate status of the output ramps specified in bits 08 to 15 of word 13.	ON: Enabled OFF: Disabled	0	R
10	0 to 7	1 to 8	Upper/Lower Limit Enabled Flags	Turned ON by the Analog Output Unit to indicate status of the upper/lower limit function specified in bits 00 to 07 of word 14.	ON: Enabled OFF: Disabled	0	R
	8 to 15	1 to 8	BCD/Binary Mode Selection Flags	Turned ON by the Analog Output Unit to indicate selection of either the BCD or binary mode specified in bits 08 to 15 of word 14.	ON: BCD OFF: Binary	1	R
11	0 to 7	1 to 8	Conversion Data Enabled Flags	Turned ON by the Analog Output Unit to indicate the output points specified in bits 00 to 07 of word 15.	ON: Enabled OFF: Disabled	0	R

Words	Bits	Output points	Name	Description	Data	Default	Read: R Write: W
12	0 to 15		Read Pointer	Specifies the first RAM address from which data is to be read when the READ instruction is executed from the CPU Unit. It is set in the WRIT instruction with the number of words transferred set to 1.	0000 to 0061 (BCD)	0000 (BCD)	(Pointer)
13	0 to 7	1 to 8	Scaling Enable Bits	Set by the user to enable or disable the scaling for each output point.	ON: Enabled OFF: Disabled	0	R/W
	8 to 15	1 to 8	Output Ramp Enable Bits	Set by the user to enable or disable the output ramp for each output point.	ON: Enabled OFF: Disabled	0	R/W
14	0 to 7	1 to 8	Upper/Lower Limit Enable Bits	Set by the user to enable or disable the upper/lower limits for each output point.	ON: Enabled OFF: Disabled	0	R/W
	8 to 15	1 to 8	BCD/Binary Mode Bits	Set by the user to select either BCD or binary data. The same data format is used for all data for each output point. Conversion data: Addresses 01 to 08 Scaling upper and lower limits: Addresses 17 to 32 Output ramp set time: Addresses 33 to 40 Upper/lower limits: Addresses 41 to 56	ON: BCD OFF: Binary	1	R/W
15	0 to 7	1 to 8	Conversion Data Enable Bits	Set by the user to enable or disable each output point. Conversion will be performed for only the enabled output points.	ON: Enabled OFF: Disabled	1	R/W
16	0 to 15	1 to 8	Conversion Speed Mode Setting	Set by the user to select the conversion speed mode for all output points.	0000 _{Hex} : Normal FFFF _{Hex} : High-speed	0000 _{Hex}	R/W

Words	Bits	Output points	Name	Description	Data	Default	Read: R Write: W
17	0 to 15	1	Scaling Lower Limit for Output Point 1	Scaling lower limit for output point 1. Set in engineering units.	BCD: -7999 to 7999 (F999 to 7999 _{Hex})	Lower limit: 0000 _{Hex} Upper limit: 4095 _{Hex}	R/W
18	0 to 15		Scaling Upper Limit for Output Point 1	Scaling upper limit for output point 1. Set in engineering units.	Binary: -32767 to 32767 (8001 to 7FFF _{Hex})		
19	0 to 15	2	Scaling Lower Limit for Output Point 2	Scaling lower limit for output point 2. Set in engineering units.	Be sure to set values within the allowable range regardless of whether the scaling function is enabled. If values outside the range are set, the Invalid Data Received Flag and other related flags may turn ON.		
20	0 to 15		Scaling Upper Limit for Output Point 2	Scaling upper limit for output point 2. Set in engineering units.			
21	0 to 15	3	Scaling Lower Limit for Output Point 3	Scaling lower limit for output point 3. Set in engineering units.			
22	0 to 15		Scaling Upper Limit for Output Point 3	Scaling upper limit for output point 3. Set in engineering units.			
23	0 to 15	4	Scaling Lower Limit for Output Point 4	Scaling lower limit for output point 4. Set in engineering units.			
24	0 to 15		Scaling Upper Limit for Output Point 4	Scaling upper limit for output point 4. Set in engineering units.			
25	0 to 15	5	Scaling Lower Limit for Output Point 5	Scaling lower limit for output point 5. Set in engineering units.			
26	0 to 15		Scaling Upper Limit for Output Point 5	Scaling upper limit for output point 5. Set in engineering units.			
27	0 to 15	6	Scaling Lower Limit for Output Point 6	Scaling lower limit for output point 6. Set in engineering units.			
28	0 to 15		Scaling Upper Limit for Output Point 6	Scaling upper limit for output point 6. Set in engineering units.			
29	0 to 15	7	Scaling Lower Limit for Output Point 7	Scaling lower limit for output point 7. Set in engineering units.			
30	0 to 15		Scaling Upper Limit for Output Point 7	Scaling upper limit for output point 7. Set in engineering units.			
31	0 to 15	8	Scaling Lower Limit for Output Point 8	Scaling lower limit for output point 8. Set in engineering units.			
32	0 to 15		Scaling Upper Limit for Output Point 8	Scaling upper limit for output point 8. Set in engineering units.			

Words	Bits	Output points	Name	Description	Data	Default	Read: R Write: W
33	0 to 15	1	Output Ramp Set Time for Output Point 1	Output ramp set time for output point 1 (in ms). It must be 8 ms or more.	BCD: 8 to 7999 (0008 to 7999 _{Hex}) Binary: 8 to 32767 (0008 to 7FFF _{Hex})	0008 _{Hex}	R/W
34	0 to 15	2	Output Ramp Set Time for Output Point 2	Output ramp set time for output point 2 (in ms). It must be 8 ms or more.			
35	0 to 15	3	Output Ramp Set Time for Output Point 3	Output ramp set time for output point 3 (in ms). It must be 8 ms or more.			
36	0 to 15	4	Output Ramp Set Time for Output Point 4	Output ramp set time for output point 4 (in ms). It must be 8 ms or more.			
37	0 to 15	5	Output Ramp Set Time for Output Point 5	Output ramp set time for output point 5 (in ms). It must be 8 ms or more.			
38	0 to 15	6	Output Ramp Set Time for Output Point 6	Output ramp set time for output point 6 (in ms). It must be 8 ms or more.			
39	0 to 15	7	Output Ramp Set Time for Output Point 7	Output ramp set time for output point 7 (in ms). It must be 8 ms or more.			
40	0 to 15	8	Output Ramp Set Time for Output Point 8	Output ramp set time for output point 8 (in ms). It must be 8 ms or more.			

Words	Bits	Output points	Name	Description	Data	Default	Read: R Write: W
41	0 to 15	1	Output Lower Limit for Output Point 1	Output lower limit for output point 1. This is used to restrict the output signal range. When the scaling function is enabled, data is set in engineering units.	With No Scaling BCD: 0 to 4095 (0000 to 4095 _{Hex}) or -2048 to 2048 (A048 to 2048 _{Hex}) Binary: 0000 to 0FFF _{Hex} or F800 to 07FF _{Hex}	Lower limit: 0000 _{Hex} Upper limit: 4095 _{Hex}	R/W
42	0 to 15		Output Upper Limit for Output Point 1	Output upper limit for output point 1. This is used to restrict the output signal range. When the scaling function is enabled, data is set in engineering units.			
43	0 to 15	2	Output Lower Limit for Output Point 2	Output lower limit for output point 2. This is used to restrict the output signal range. When the scaling function is enabled, data is set in engineering units.	With Scaling BCD: -7999 to 7999 (F999 to 7999 _{Hex}) Binary: -32767 to 32767 (8001 to 7FFF _{Hex}) Be sure to set values within the allowable range regardless of whether the upper/lower limit function is enabled. If values outside the range are set, the Upper/Lower Limit Over Flag and other related flags may turn ON.		
44	0 to 15		Output Upper Limit for Output Point 2	Output upper limit for output point 2. This is used to restrict the output signal range. When the scaling function is enabled, data is set in engineering units.			
45	0 to 15	3	Output Lower Limit for Output Point 3	Output lower limit for output point 3. This is used to restrict the output signal range. When the scaling function is enabled, data is set in engineering units.			
46	0 to 15		Output Upper Limit for Output Point 3	Output upper limit for output point 3. This is used to restrict the output signal range. When the scaling function is enabled, data is set in engineering units.			
47	0 to 15	4	Output Lower Limit for Output Point 4	Output lower limit for output point 4. This is used to restrict the output signal range. When the scaling function is enabled, data is set in engineering units.			
48	0 to 15		Output Upper Limit for Output Point 4	Output upper limit for output point 4. This is used to restrict the output signal range. When the scaling function is enabled, data is set in engineering units.			

Words	Bits	Output points	Name	Description	Data	Default	Read: R Write: W
49	0 to 15	5	Output Lower Limit for Output Point 5	Output lower limit for output point 5. This is used to restrict the output signal range. When the scaling function is enabled, data is set in engineering units.	With No Scaling BCD: 0 to 4095 (0000 to 4095 _{Hex}) or -2048 to 2048 (A048 to 2048 _{Hex}) Binary: 0000 to 0FFF _{Hex} or F800 to 07FF _{Hex}	Lower limit: 0000 _{Hex} Upper limit: 4095 _{Hex}	R/W
50	0 to 15		Output Upper Limit for Output Point 5	Output upper limit for output point 5. This is used to restrict the output signal range. When the scaling function is enabled, data is set in engineering units.			
51	0 to 15	6	Output Lower Limit for Output Point 6	Output lower limit for output point 6. This is used to restrict the output signal range. When the scaling function is enabled, data is set in engineering units.	With Scaling BCD: -7999 to 7999 (F999 to 7999 _{Hex}) Binary: -32767 to 32767 (8001 to 7FFF _{Hex}) Be sure to set values within the allowable range regardless of whether the upper/lower limit function is enabled. If values outside the range are set, the Upper/Lower Limit Over Flag and other related flags may turn ON.		
52	0 to 15		Output Upper Limit for Output Point 6	Output upper limit for output point 6. This is used to restrict the output signal range. When the scaling function is enabled, data is set in engineering units.			
53	0 to 15	7	Output Lower Limit for Output Point 7	Output lower limit for output point 7. This is used to restrict the output signal range. When the scaling function is enabled, data is set in engineering units.			
54	0 to 15		Output Upper Limit for Output Point 7	Output upper limit for output point 7. This is used to restrict the output signal range. When the scaling function is enabled, data is set in engineering units.			
55	0 to 15	8	Output Lower Limit for Output Point 8	Output lower limit for output point 8. This is used to restrict the output signal range. When the scaling function is enabled, data is set in engineering units.			
56	0 to 15		Output Upper Limit for Output Point 8	Output upper limit for output point 8. This is used to restrict the output signal range. When the scaling function is enabled, data is set in engineering units.			
57	0 to 15	1 to 8	Invalid Data Received Address	The last RAM address that received invalid data	0000 to 0061 (BCD)	---	R

Words	Bits	Output points	Name	Description	Data	Default	Read: R Write: W
58	0 to 15	1 to 8	Invalid Data Received Error Code	Error when invalid data was received	0001 _{Hex} : Invalid BCD value 0002 _{Hex} : Outside the scaling limits 0003 _{Hex} : Outside the conversion range 0004 _{Hex} : Other than 0000 _{Hex} and FFFF _{Hex} 0005 _{Hex} : 8000 _{Hex} is invalid. 0006 _{Hex} : Scaling lower and upper limits are the same. 0007 _{Hex} : Negative values are invalid. 0008 _{Hex} : Lower limit is greater than upper limit.	---	R
59	0 to 15	1 to 8	Total EEPROM Write Count	Total number of write operations to EEPROM	0000 to 9999 (BCD)	---	R
60	0 to 15	1 to 8	EEPROM Write Result	An error flag for write operation to EEPROM	0002 _{Hex} : A total of 5,000 write operations performed for EEPROM. 0004 _{Hex} : A total of 10,000 write operations performed for EEPROM. 0008 _{Hex} , 0010 _{Hex} , 0020 _{Hex} , or 0040 _{Hex} : Error occurred in Unit during diagnosis after power was turned ON. Replace the Unit.	---	R
61	0 to 15	1 to 8	Total EEPROM Write Count Setting	The total EEPROM write count (address 59) is set in this word for writing data to EEPROM. If the EEPROM Write Bit (bit 3 of word n or n+1) is then turned ON, data will be written from RAM to EEPROM. At the same time, the total EEPROM write count (address 59) will be incremented by 1.	---	---	R/W

9-4 Functions

9-4-1 BCD/Binary Mode

The BCD/Binary Mode Bits (bits 8 to 15 of address 14) in RAM of the Analog Output Unit are used to select either BCD or binary mode for each output point. The default is BCD mode.

The data format is specified for the following four values in RAM by using the BCD/Binary Mode Bit.

1. Conversion data
2. Scaling upper and lower limits
3. Output ramp set time
4. Upper and lower limits

To enable the BCD/Binary Mode Bit, turn ON this bit, and turn ON the Parameter Update Bit in the allocated I/O words. Conversion data in RAM will be rewritten and the Analog Output Unit will generate output signals according to the new parameter settings.

BCD/Binary Mode Bits

The BCD/Binary Mode Bits are used to set either BCD or binary mode individually for each output point. Turning ON a bit sets BCD mode. In this case, all the conversion data, scaling upper and lower limits, output ramp set time, and upper and lower limits that are written to RAM will be handled in BCD format.

If there is inconvertible data, the Conversion Error Flag will be set. Data that has been written to RAM before the BCD/Binary Mode Bit is set is treated as BCD data and is not converted into BCD format. If data is invalid for BCD format, the Invalid Data Received Flag will be set and the entire data block containing the invalid data will be discarded.

Turning OFF the BCD/Binary Mode Bit sets binary mode. In this case, all the conversion data, scaling upper and lower limits, output ramp set time, and upper and lower limits that are written to RAM will be handled in binary format. Data that has been written to RAM before the BCD/Binary Mode Bit is set is treated as binary data and is not converted into binary format. No conversion or invalid data errors occur when data is converted into binary format.

BCD/Binary Mode Flag

The BCD/Binary Mode Flag is turned ON to notify the CPU Unit of the data format setting (BCD or binary). This flag is read-only.

9-4-2 Scaling

The scaling function automatically scales data set in engineering units (converts to a rate of 0% to 100%) and generates output signals. It can be set individually for each output point. Reverse scaling is also possible.

To enable scaling, set the scaling upper and lower limits, turn ON the Scaling Enable Bit, and turn ON the Parameter Update Bit in the allocated I/O words. Conversion data in RAM will be rewritten and the Analog Output Unit will generate output signals according to the new parameter settings.

Scaling Upper and Lower Limits

Limit	BCD	Binary
Scaling upper limit	F999 to 7999 _{Hex}	8001 to 7FFF _{Hex}
Scaling lower limit	(Decimal: -7999 to 7999)	(Decimal: -32767 to 32767)

When the scaling lower limit is smaller than the scaling upper limit, the lower limit corresponds to output signal level 0%, the upper limit corresponds to output signal level 100%, and positive scaling is performed.

When the scaling lower limit is greater than the scaling upper limit, the lower limit corresponds to output signal level 100%, the upper limit corresponds to output signal level 0%, and reverse scaling is performed.

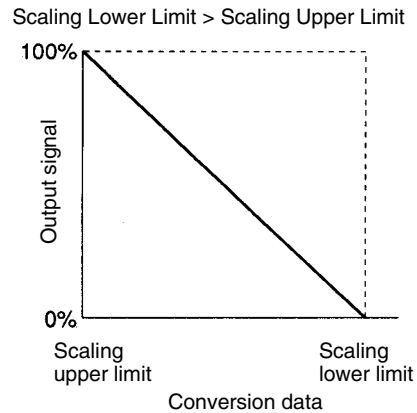
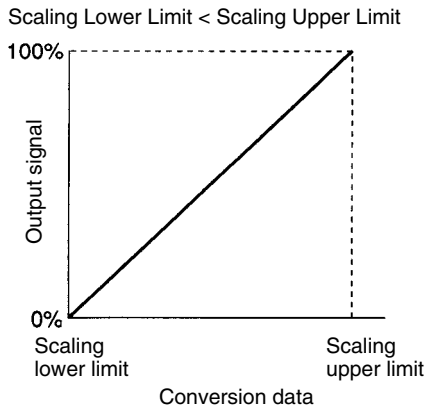

Output Signals

Conversion data set in engineering units is converted into a rate of 0% to 100% (0 to 4095) according to the scaling upper and lower limits, subject to conversion, and then generated as output signals.

Scaling Enable Bits

To enable scaling, turn ON the Scaling Enable Bit for each output point. These bits are read/write.

Scaling Enabled Flags

To check whether the scaling function is active, monitor the status of the Scaling Enabled Flag for each output point. These flags are read-only.

Examples of Positive Scaling

Example 1: 0 to 5 V output for 0 to 100%

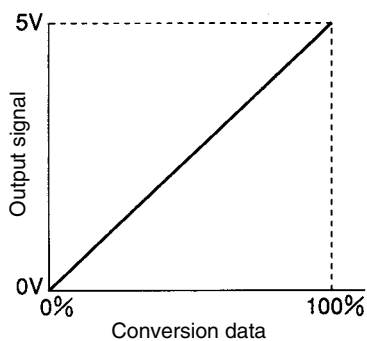

Example 2: 4 to 20 mA output for -100 to 200°C

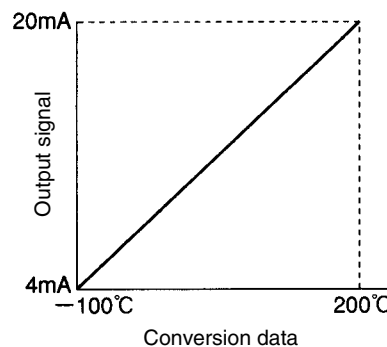

Output Point 1

Address	Bit	Function	Settings	
			Example 1	Example 2
13	0	Scaling Enable Bit	ON (Enabled)	ON (Enabled)
14	8	BCD/Binary Mode Bit	ON (BCD)	ON (BCD)
17	1 to 15	Scaling Lower Limit	0000 _{Hex}	8100 _{Hex}
18	1 to 15	Scaling Upper Limit	0100 _{Hex}	0200 _{Hex}

Examples of Reverse Scaling

Example 3: 0 to 5 V output for 0 to 100%

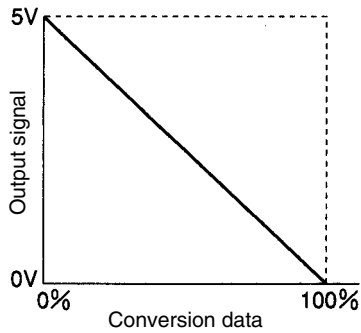

Example 4: 4 to 20 mA output for 300 to 0°C

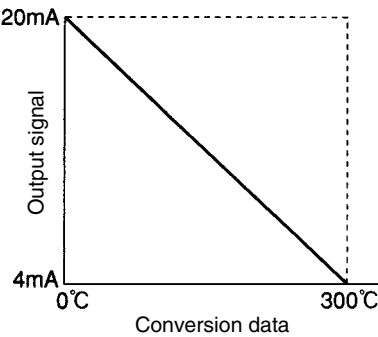

Output Point 3

Address	Bit	Function	Settings	
			Example 3	Example 4
13	2	Scaling Enable Bit	ON (Enabled)	ON (Enabled)
14	10	BCD/Binary Mode Bit	ON (BCD)	ON (BCD)
21	1 to 15	Scaling Lower Limit	0100 _{Hex}	0300 _{Hex}
22	1 to 15	Scaling Upper Limit	0000 _{Hex}	0000 _{Hex}

9-4-3 Output Ramps

The output ramps make output signals gradually change with time to prevent sudden changes in response to Conversion data fluctuations. The time required to change the present value to a new value is set in ms. This function can be set individually for each output point.

When an output signal reaches the new value after the ramp set time elapses, the output signal holds that value if there is no new change in the conversion data. Therefore, when using this function, change conversion data only if output needs to be changed.

To enable the output ramp function, set the output ramp set time, turn ON the Output Ramp Enable Bit, and turn ON the Parameter Update Bit in the allocated I/O words. Conversion data in RAM will be rewritten and the Analog Output Unit will generate output signals according to the new parameter settings.

Output Ramp Set Time

Set the output ramp set time in ms. The setting range depends on the data format (BCD or binary mode) as shown in the following table. The output ramp set time must be 8 ms or greater.

	BCD	Binary
Output ramp set time (Unit: ms)	0008 to 7999 _{Hex} (Decimal: 8 to 7999)	0008 to 7FFF _{Hex} (Decimal: 8 to 32767)

- Note**
1. If a value outside the setting range is set, other data will not be written (to RAM).
 2. Because conversion data is updated every 8 ms, the time required for an output signal to reach a new value is a multiple of 8 ms. Therefore, the maximum output ramp set time accuracy is + 8 ms.

Output Signals

When conversion data changes from the present value to a new value, the output signal is linearly changed to the new value within the output ramp set time instead of rapidly changing the output signal. Once the output signal reaches the new value, it remains unchanged until conversion data changes.

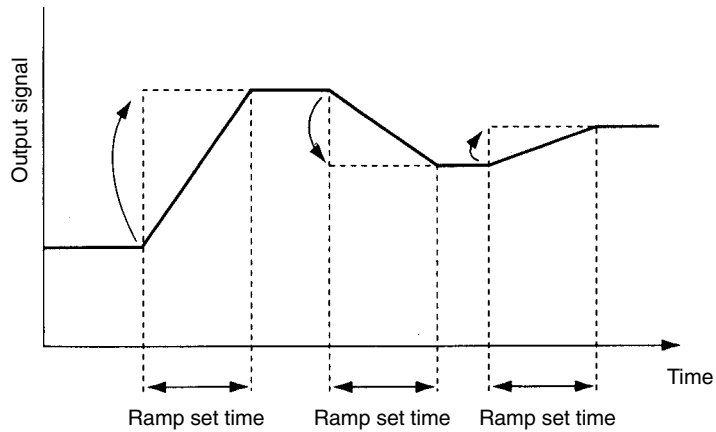

If conversion data changes before the output ramp set time is reached, a new output ramp operation will be started by using the output value at that point of time as the present value.

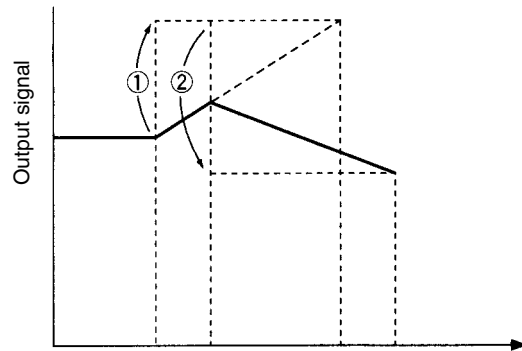

Output Ramp Enable Bits

To enable the output ramp function, turn ON the Output Ramp Enable Bit for each output point. These bits are read/write.

Output Ramp Enabled Flags

To check whether the output ramp function is active, monitor the status of the Output Ramp Enabled Flag for each output point. These flags are read-only.

Example: Output Ramp for 5 Seconds

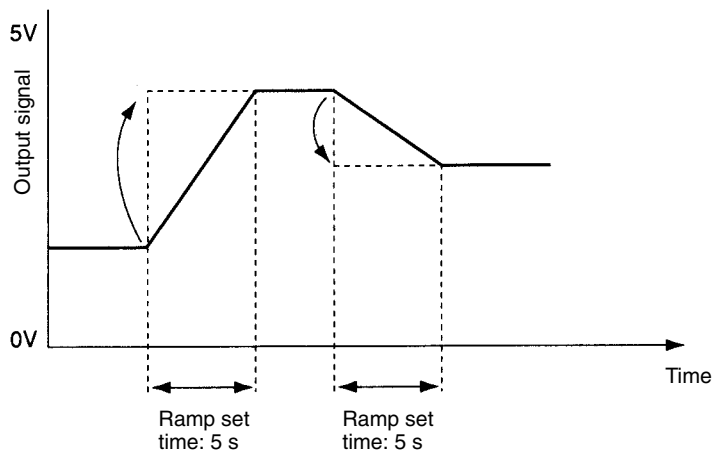

Output Point 1

Address	Bit	Function	Settings	
			BCD mode	Binary mode
13	8	Output Ramp Enable Bit	ON (Enabled)	ON (Enabled)
14	8	BCD/Binary Mode Bit	ON (BCD)	OFF (Binary)
33	1 to 15	Output Ramp Set Time (ms)	5000 _{Hex}	1388 _{Hex}

9-4-4 Upper/Lower Limits

The upper/lower limit function is used to restrict output signals so that conversion data above the upper limit or below the lower limit is made constant. This function can be set individually for each output point.

Even if data above the upper limit or below the lower limit is set as conversion data in RAM, the upper or lower limit value will be stored in RAM whichever applicable.

When the scaling function is enabled, set the upper and lower limits in engineering units. Even if reverse scaling is specified, the lower limit must be smaller than the upper limit.

To enable the upper/lower limit function, set the upper and lower limits, turn ON the Upper/Lower Limit Enable Bit, and turn ON the Parameter Update Bit in the allocated I/O words. Conversion data in RAM will be rewritten and the Analog Output Unit will generate output signals according to the new parameter settings.

Upper and Lower Limits

Limits	Scaling setting	Output signal	BCD	Binary
Upper and lower limits	Scaling disabled	0 to 10 V 0 to 5 V 0 to 20 mA 4 to 20 mA	0000 to 4095 (Decimal: 0 to 4095)	0000 to 0FFF (Decimal: 0 to 4095)
		-5 to 5 V -10 to 10 V	A048 to 2047 (Decimal: -2048 to 2047)	F800 to 07FF (Decimal: -2048 to 2047)
	Scaling enabled		F999 to 7999 _{Hex} (Decimal: -7999 to 7999)	8001 to 7FFF _{Hex} (Decimal: -32767 to 32767)

Output Signals

When conversion data exceeds the upper limit, the output signal remains at the upper limit. Likewise, when conversion data drops below the lower limit, the output signal remains at the lower limit.

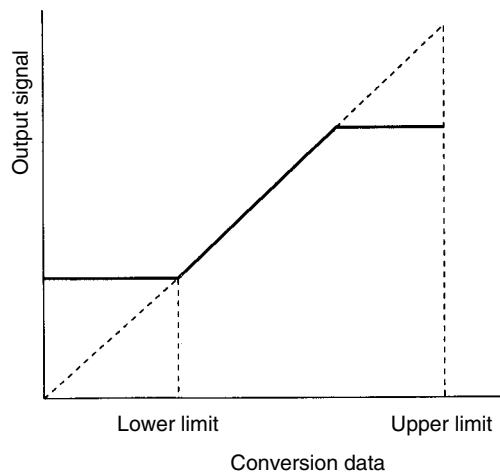

Upper/Lower Limit Enable Bits

To enable the upper/lower limit function, turn ON the Upper/Lower Limit Enable Bit for each output point. These bits are read/write.

Upper/Lower Limit Enabled Flags

To check whether the upper/lower limit function is active, monitor the status of the Upper/Lower Limit Enabled Flag for each output point. These flags are read-only.

Example: Output of 4 to 20 mA for 0 to 300°C

When the lower and upper limits are set to 45°C and 270°C, respectively, output signals will be restricted to 6.4 mA at 45°C or lower and to 18.4 mA at 270°C or higher.

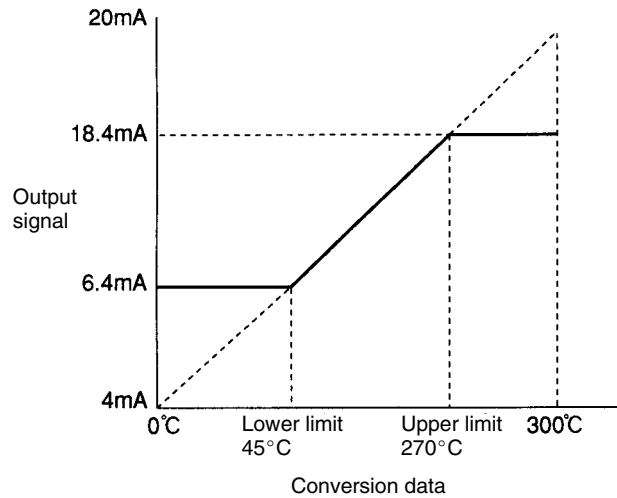

Output Point 1

Address	Bit	Function	Settings	
			BCD mode	Binary mode
14	0	Upper/Lower Limit Enable Bit	ON (Enabled)	ON (Enabled)
14	8	BCD/Binary Mode Bit	ON (BCD)	OFF (Binary)
41	1 to 15	Lower Limit	0045 _{Hex}	002D _{Hex}
42	1 to 15	Upper Limit	0270 _{Hex}	010E _{Hex}

Example: Reverse Output of 4 to 20 mA for 0 to 300°C

When the lower and upper limits are set to 45°C and 270°C, respectively, output signals will be restricted to 17.6 mA at 45°C or lower and to 5.6 mA at 270°C or higher.

The upper/lower limit function is valid for conversion data. Therefore, even if reverse scaling is specified, the lower limit must be smaller than the upper limit.

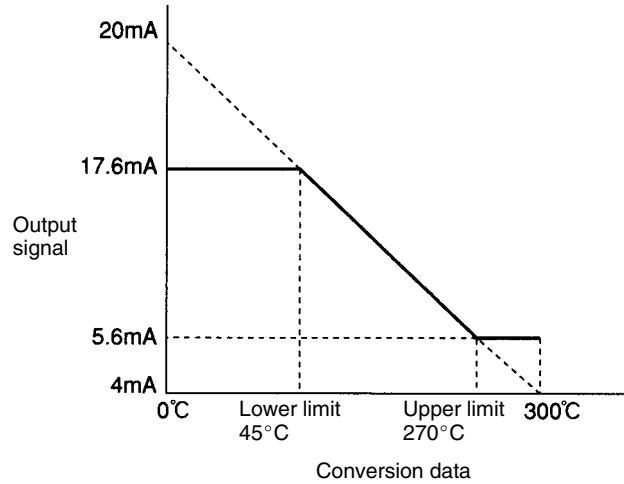

Output Point 1

Address	Bit	Function	Settings	
			BCD mode	Binary mode
14	0	Upper/Lower Limit Enable Bit	ON (Enabled)	ON (Enabled)
14	8	BCD/Binary Mode Bit	ON (BCD)	OFF (Binary)
41	1 to 15	Lower Limit	0045 _{Hex}	002D _{Hex}
42	1 to 15	Upper Limit	0270 _{Hex}	010E _{Hex}

9-5 User Programming Examples

9-5-1 Two-word Operating Mode

Writing Default Data and Conversion Data

Example:

Parameters are set in RAM addresses 13 to 18 of the Analog Output Unit and, 100 ms later, data is set in RAM address 01 (when the Analog Output Unit is allocated to words CIO 0002 to CIO 0003.)

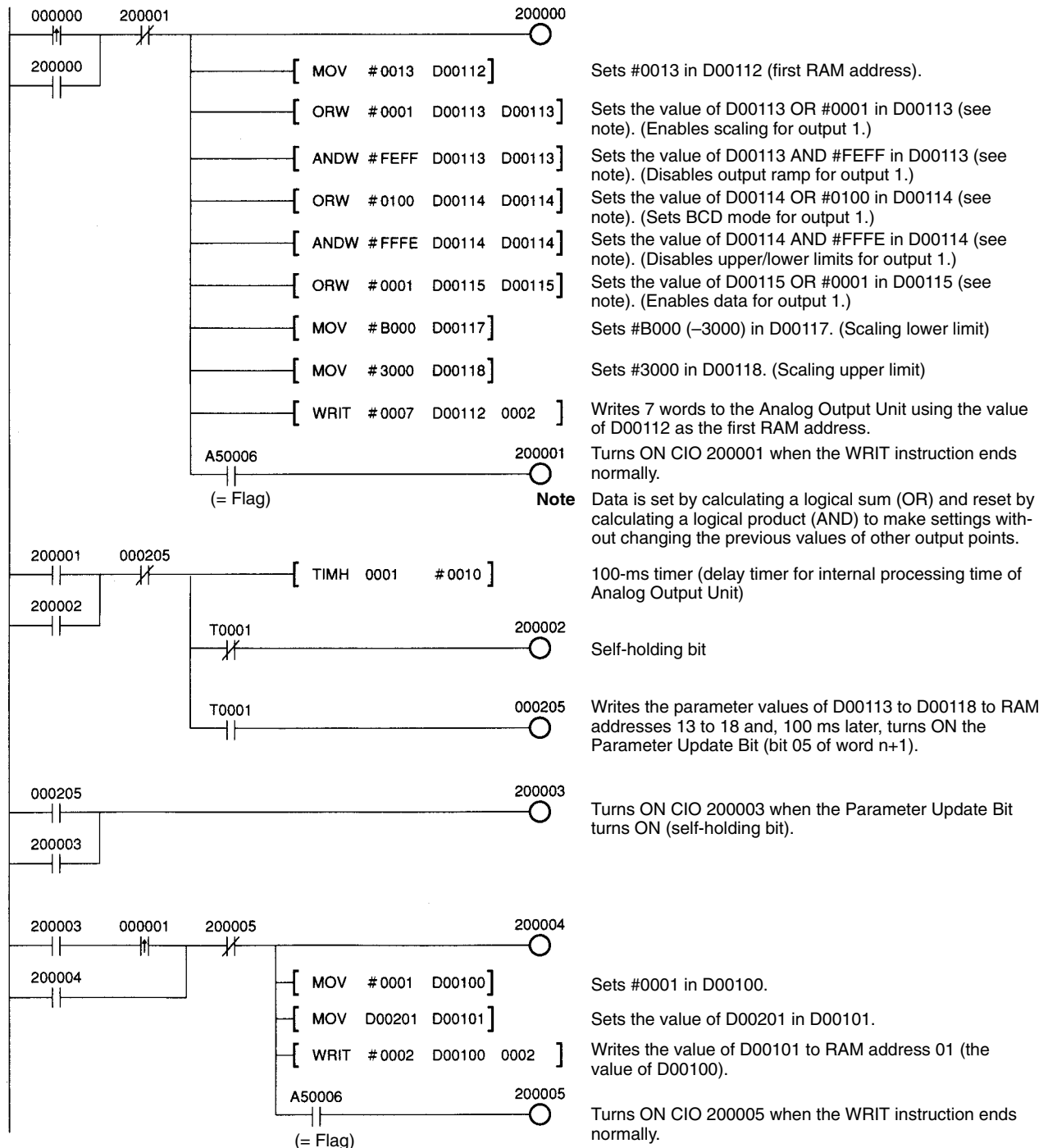

Reading Data

Reading Consecutive Data

Example:

A total of 62 words is read from RAM addresses 00 to 61 of the Analog Output Unit to addresses D00000 to D00061 (when the Analog Output Unit is allocated to words 0002 to 0003).

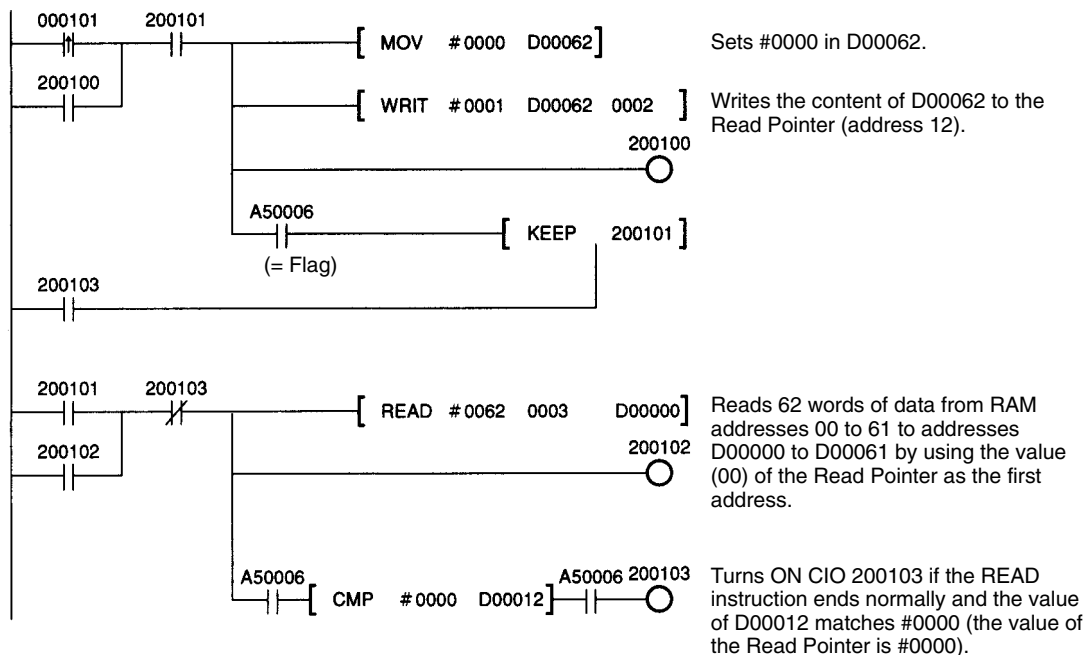

9-5-2 Four-word Operating Mode

Writing Data

Writing Default Data and Conversion Data

Example:

Parameters are set in RAM addresses 13 to 18 of the Analog Output Unit and, 100 ms later, data is set in RAM address 01 (when the Analog Output Unit is allocated to words CIO 0002 to CIO 0005.)

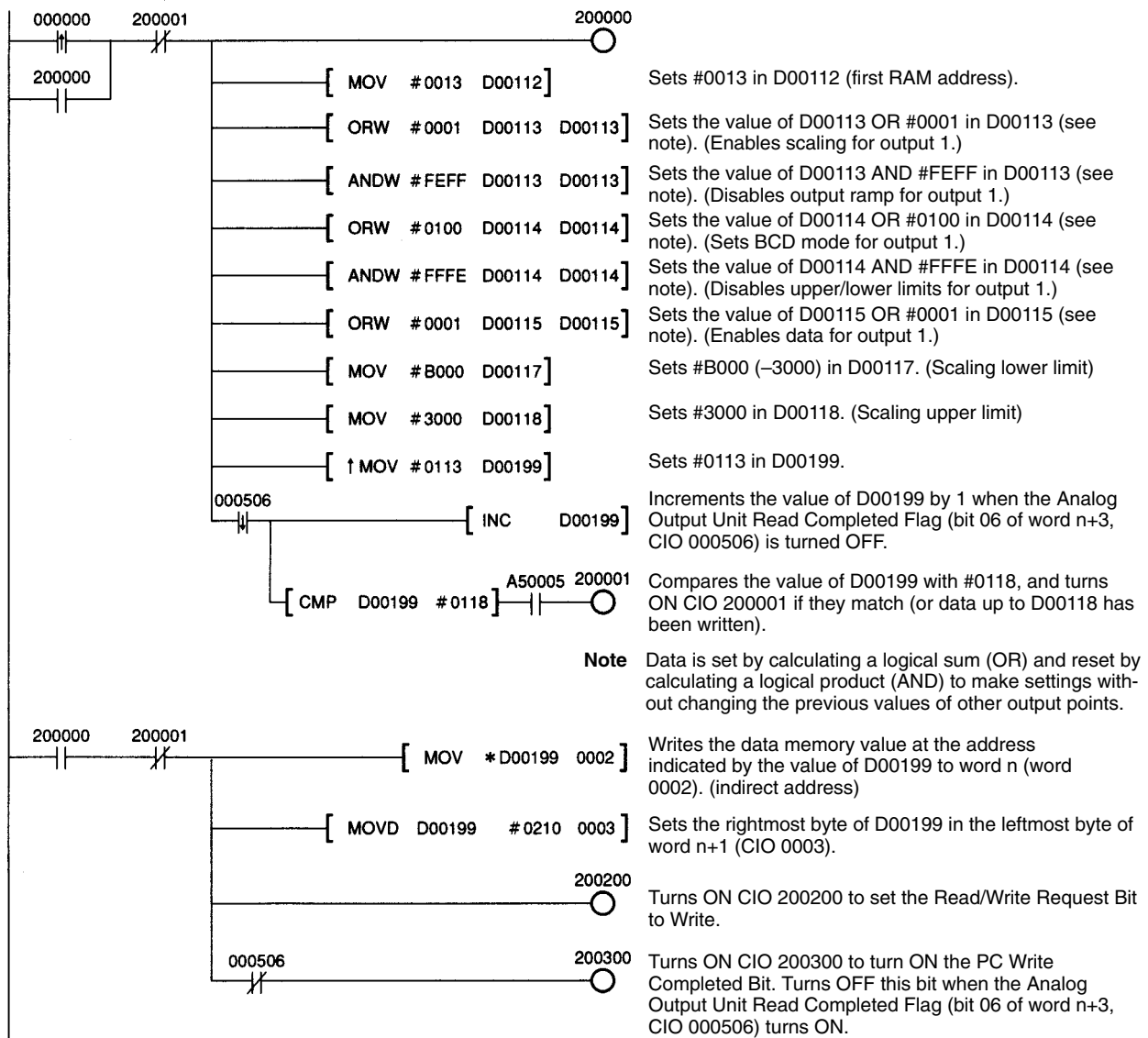

(Continued on next page)

(Continued from previous page)

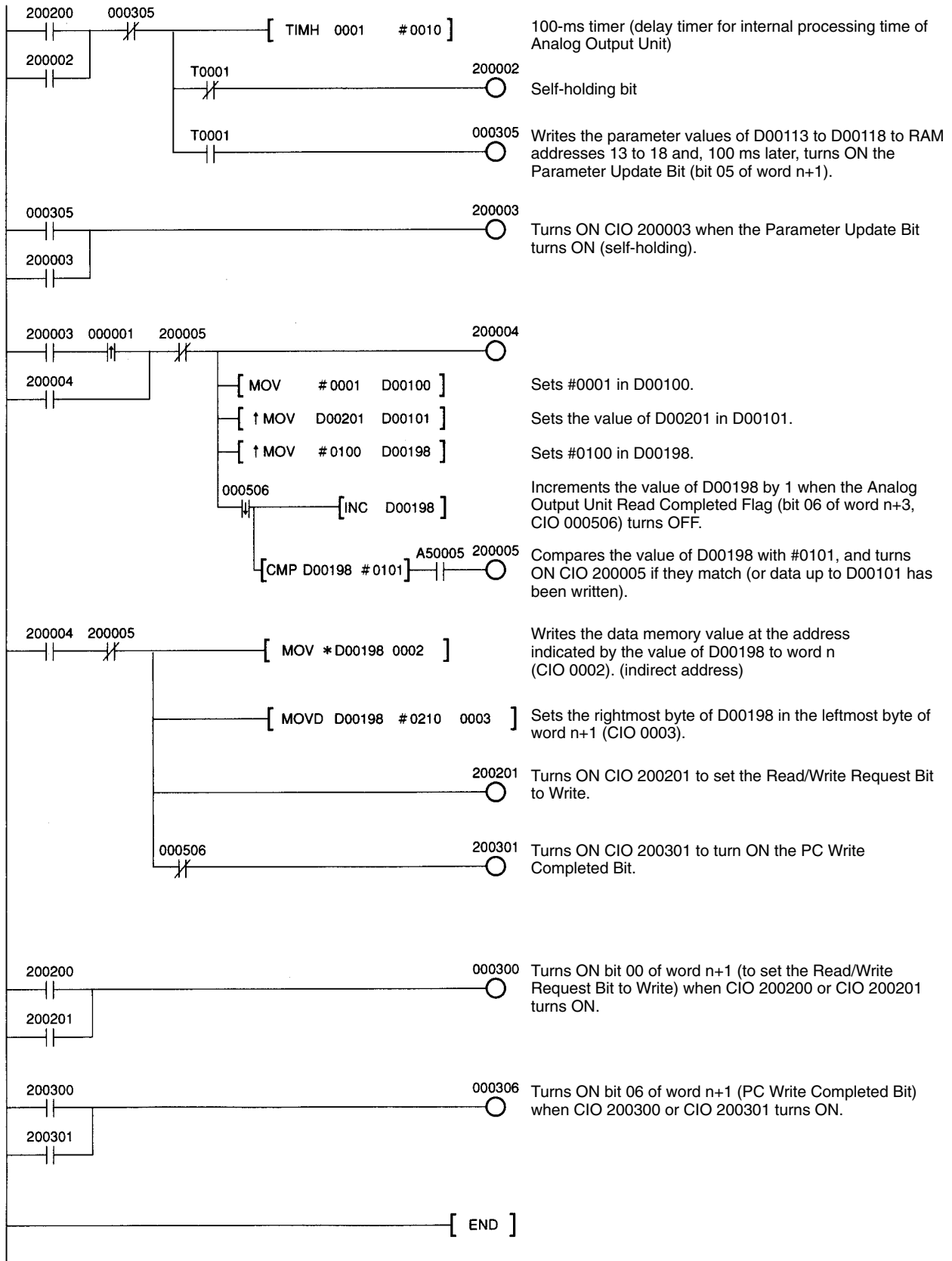

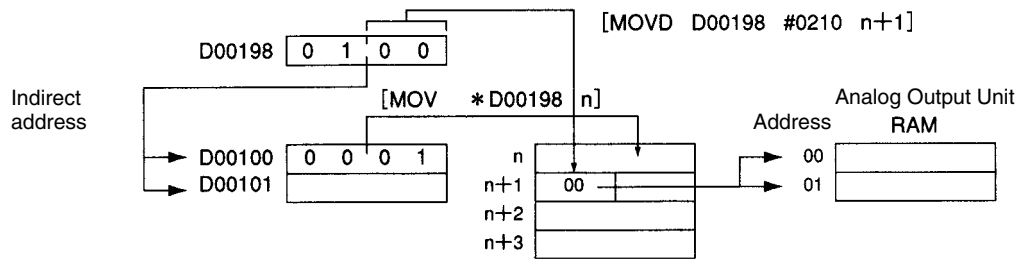
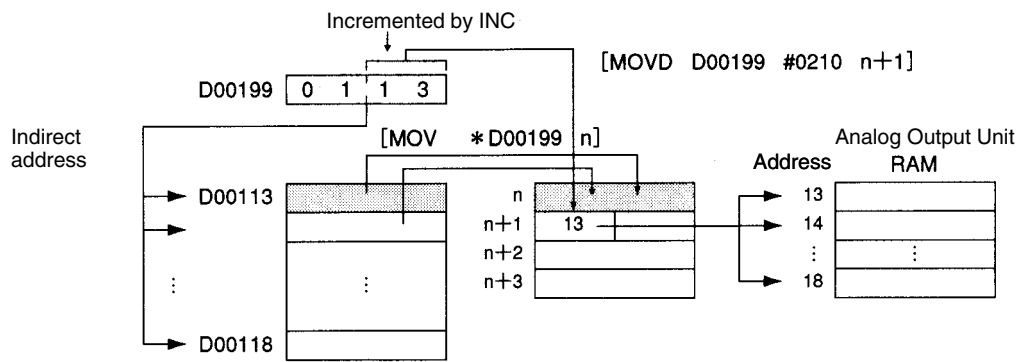

Reading Data

Example:

Data is read from RAM addresses 01 to 18 of the Analog Output Unit to addresses D00001 to D00018 (when the Analog Output Unit is allocated to words CIO 0002 to CIO 0005).

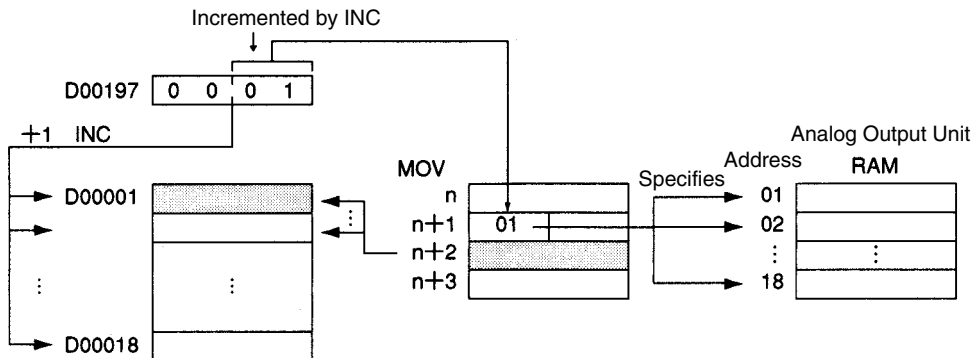
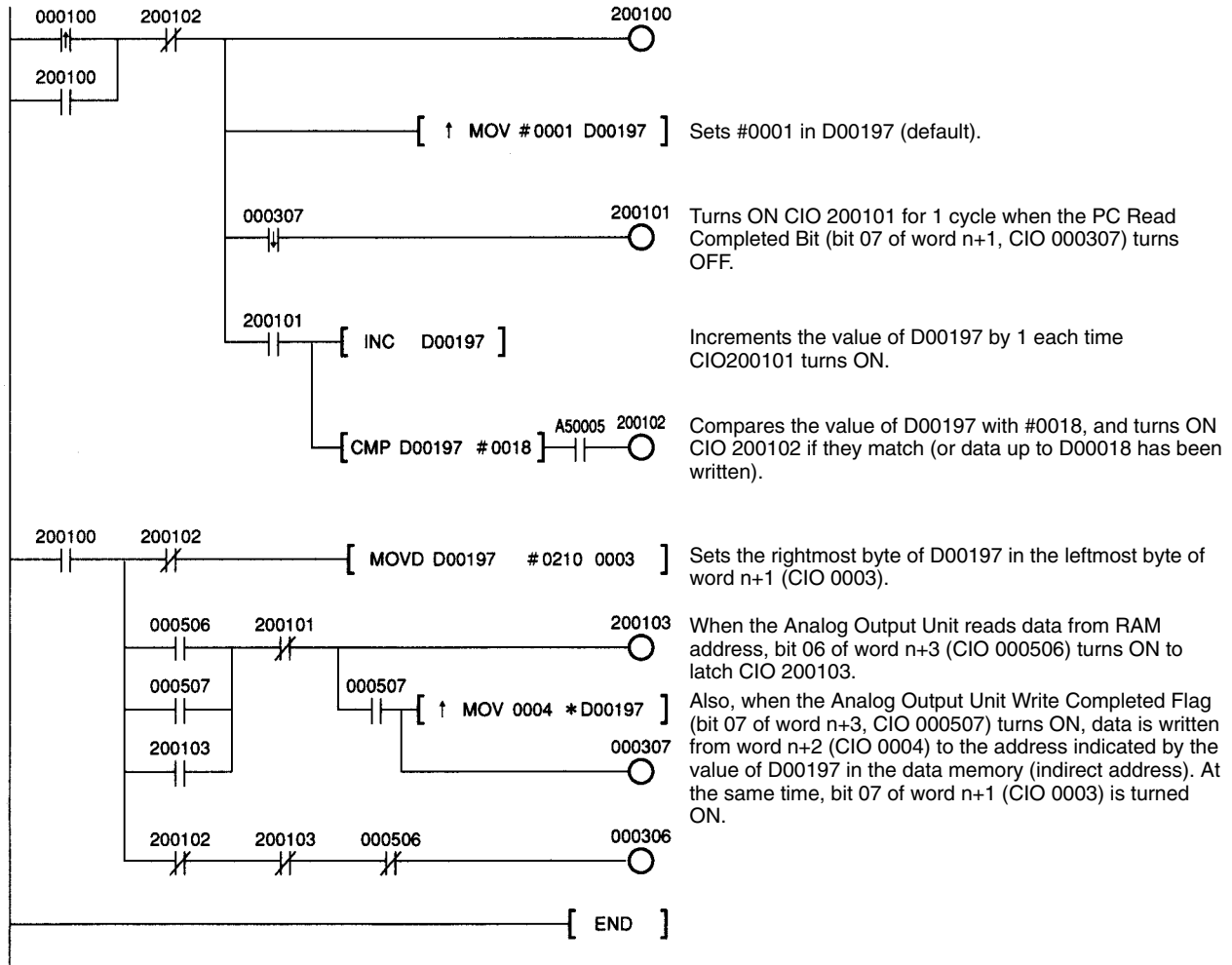

Programming Precautions in Four-word Operating Mode

In four-word operating mode, the same handshake bit in the allocated I/O words, the PC Write Completed Bit, is used for both write and read operations in the Analog Output Unit. Therefore, even if exclusive control is performed for each read and write process, when a block in a program turns ON the PC Write Completed Bit, other invalid blocks in the program may turn OFF the bit.

To prevent this problem, the following two methods are available.

- 1, 2, 3...
1. The JUMP (JMP) instruction should be used to prevent invalid blocks in the program from turning OFF the PC Write Completed Bit.
 2. Write and read processes should not be concurrently executed. Instead, only one process should be executed at a time. Also, the PC Write Completed Bit should not be directly turned ON or OFF by each write and read process. Instead, the process result should be reflected in word bits, and the PC Write Completed Bit should be turned ON or OFF according to the OR of these bits.

Method 1

In this method, execution conditions for each program block are specified in the JMP instruction to jump over invalid program blocks.

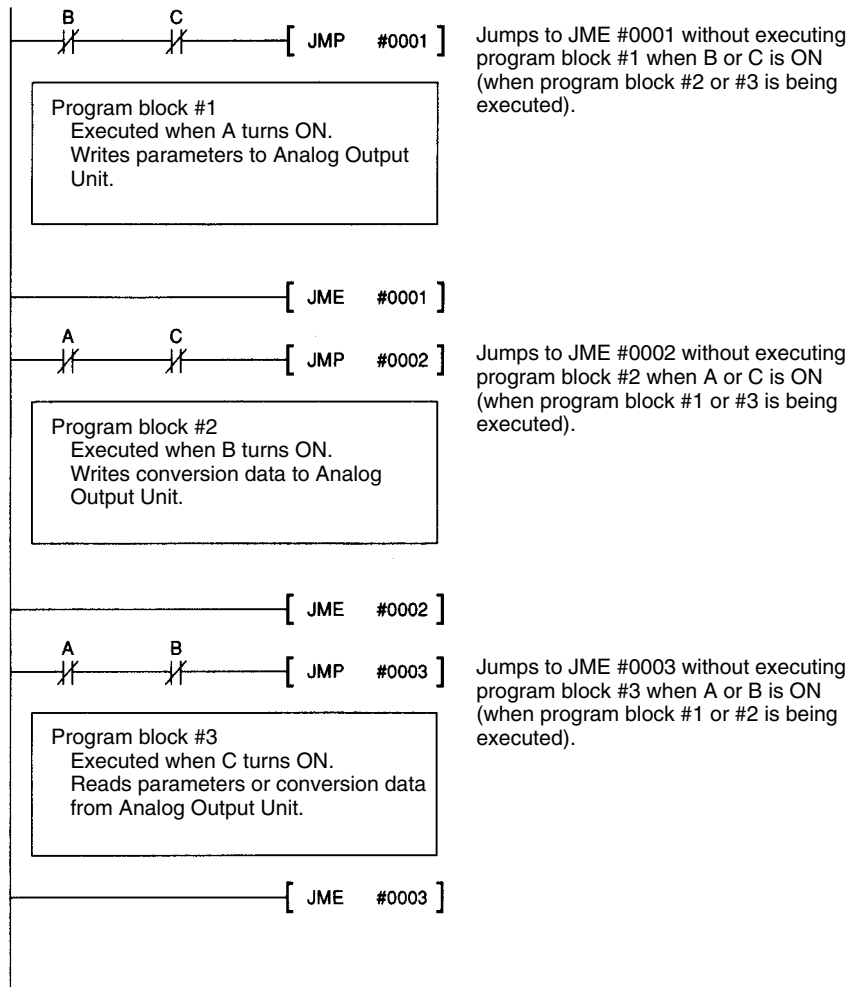

Method 2

In this method, each work bit is turned ON when PC write process is completed, and the result is set in the PC Write Completed Bit according to an OR of these bits. This prevents the PC Write Completed Bit turned ON by one program block from being turned OFF by another program block.

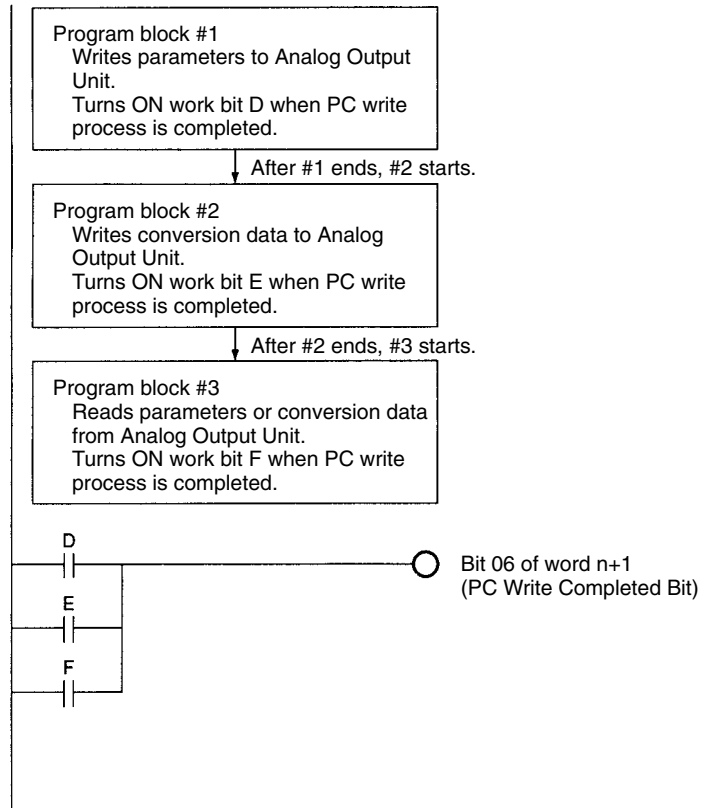
**9-5-3 Using Pulse Signals**

In the C500-DA501 Analog Output Unit, a pulse signal that turns ON and OFF every 0.5 second is output to the allocated I/O words during normal operation. These pulse signals are not output when operation is abnormal. Therefore, the CPU Unit can use this flag as an input condition to check reliability of conversion data from the Analog Output Unit.

An example of a simple program for monitoring the pulse signal is shown below.

Pulse Signal Flag: (Two-word operating mode: Bit 11 of word n+1)
 (Four-word operating mode: Bit 11 of word n+3)

Example:

A 1.5-s timer is used to monitor pulse signal ON timing. Bit A remains OFF when the pulse signal is normal, but is turned ON when pulse signal is abnormal.

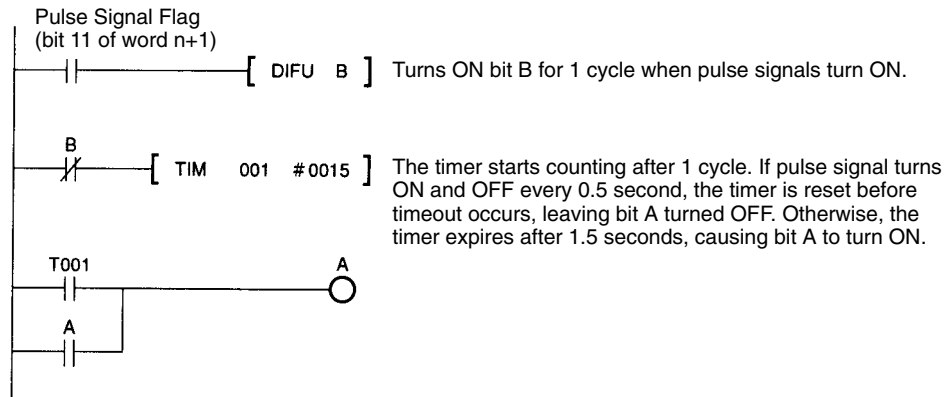

Normal Operation

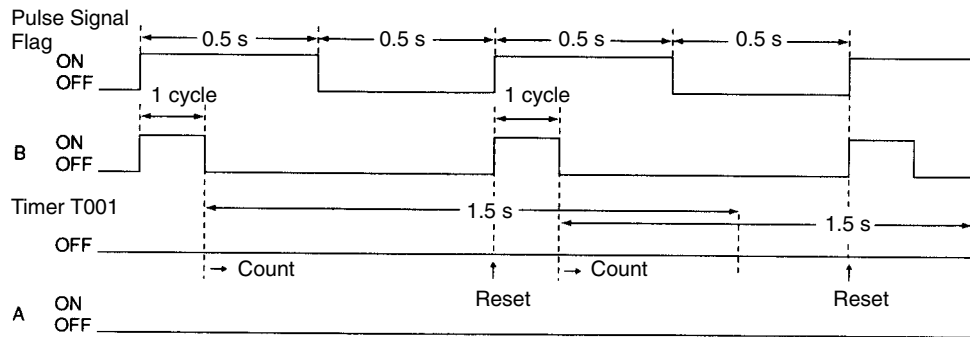

Abnormal Operation

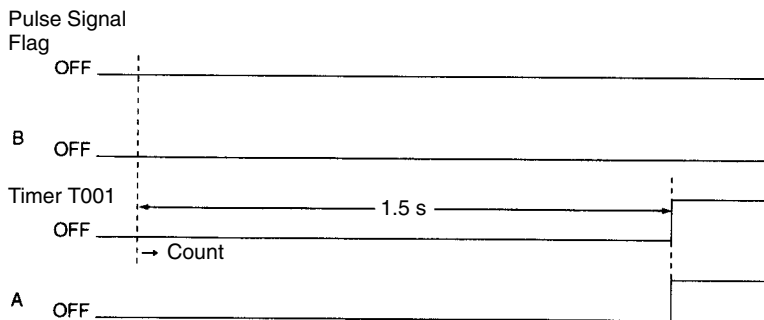

If pulse signal OFF timing is also to be monitored, a 0.8-s timer is used to monitor both pulse signal ON and OFF timing.

9-5-4 Writing EEPROM

Function

Data can be written from RAM to EEPROM. Data in RAM will be lost when the power is turned OFF. Therefore, if data needs to be stored, use this function to write it to EEPROM.

Setting Procedure

- 1, 2, 3...
1. Word 59 in RAM or EEPROM (Total EEPROM Write Count) is read and stored in DM.
 2. The value stored in DM is written to word 61 in RAM (Total EEPROM Write Count Setting).

3. Bit 3 of word n (EEPROM Write Bit) is turned ON to write data from RAM to EEPROM. When the write process has been completed, word 59 in RAM or EEPROM (Total EEPROM Write Count) is incremented by 1.

For programming examples, see *EEPROM Write Programming Example* on page 192.

EEPROM Write Count

There is a limit to the EEPROM write count. When the total EEPROM count exceeds 9,999, the RUN indicator will flash. If this occurs, replace the Unit.

EEPROM Write Result

The following bits of word 60 in RAM turn ON according to the result of the EEPROM write process.

Bit	Status
01	Turns ON when the total EEPROM write count reaches 5,000 (see note).
02	Turns ON when the total EEPROM write count reaches 10,000. At the same time, the RUN indicator flashes. Replace the Unit.
03 04 05 06	Turn ON when an internal diagnostic error occurs at startup. At the same time, the ERROR indicator lights. Replace the Unit.

Note When the total write count reaches 5,000, write 4F43 (one word only) to enable writing beyond 5,000 times. If 4F43 is not written, further writing to EEPROM will not be possible.

EEPROM Write Programming Example

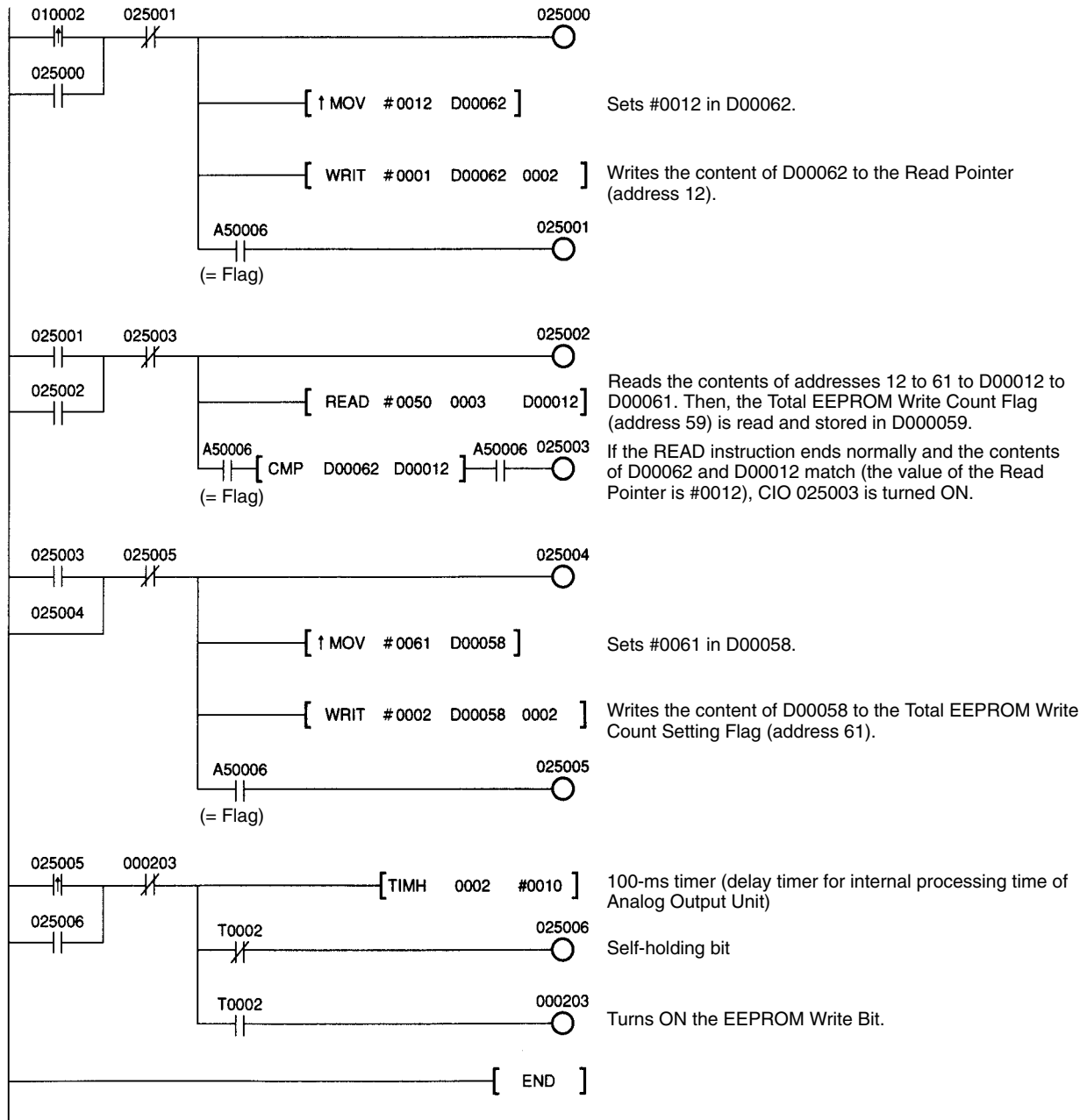

Appendix A

DM Memory Coding Sheets

C500-AD101 Analog Input Unit

DM				Data				Description	
		0	0					Specify points for mean function	Specify points to be used
		1	0			0	0	Specify points for scaling function	0 0
								Mean value 1	
								Mean value 2	
								Mean value 3	
								Mean value 4	
								Mean value 5	
								Mean value 6	
								Mean value 7	
								Mean value 8	
								Scaling offset 1	
								Scaling gain 1	
								Scaling offset 2	
								Scaling gain 2	
								Scaling offset 3	
								Scaling gain 3	
								Scaling offset 4	
								Scaling gain 4	
								Scaling offset 5	
								Scaling gain 5	
								Scaling offset 6	
								Scaling gain 6	
								Scaling offset 7	
								Scaling gain 7	
								Scaling offset 8	
								Scaling gain 8	



Caution

Input the mean value and scaling values only for points for which the mean and/or scaling function has been designated. If one of these is not needed for a point, move all other parameters up one word to replace it. For example, if a mean value is not required for input point 3 but is required for points 1, 2, and 4, the mean value for point 4 would be placed in DM m+ 04 instead of DM m+5.

C500-AD501 Analog Input Unit

Input Signal Range Settings

Input signal range	Input number															
	16	15	14	13	12	11	10	9	8	7	6	5	4	3	2	1
0 to 5 V																
0 to 10 V																
-5 to 5 V																
-10 to 10 V																
0 to 20 mA																
-20 to 20 mA																

Input range	DIP switch pin settings				Slide switch settings
	5	6	7	8	
	1	2	3	4	
0 to 5 V	OFF	OFF	ON	ON	Voltage input
0 to 10 V	OFF	OFF	OFF	OFF	
-5 to 5 V	ON	ON	ON	ON	
-10 to 10 V	ON	ON	OFF	OFF	
0 to 20 mA	OFF	OFF	ON	ON	Current input
-20 to 20 mA	ON	ON	ON	ON	

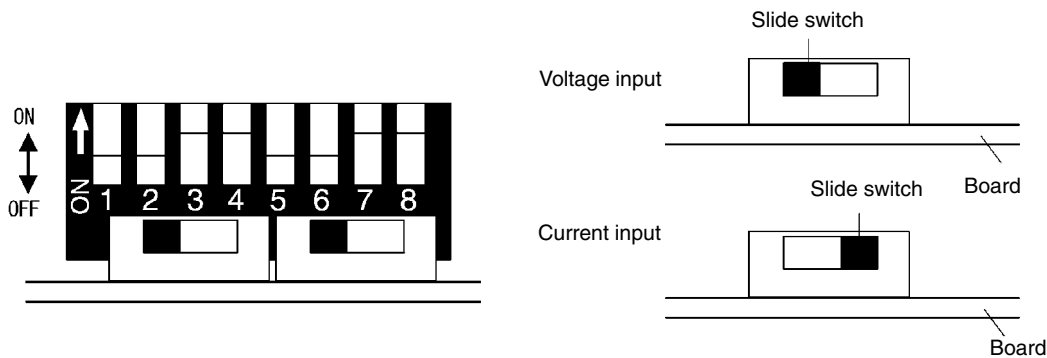

- Note**
1. Turn OFF the power to the PC before changing the above settings.
 2. The above settings are enabled when the power supply to the PC is turned ON.

DM word	Unit memory map	Function	Decimal value	Hex/BCD value			
	75	Low alarm limit – input point 11					
	76	High alarm limit – input point 11					
	77	Low alarm limit – input point 12					
	78	High alarm limit – input point 12					
	79	Low alarm limit – input point 13					
	80	High alarm limit – input point 13					
	81	Low alarm limit – input point 14					
	82	High alarm limit – input point 14					
	83	Low alarm limit – input point 15					
	84	High alarm limit – input point 15					
	85	Low alarm limit – input point 16					
	86	High alarm limit – input point 16					
	87	Filtering time constant – input point 1					
	88	Filtering time constant – input point 2					
	89	Filtering time constant – input point 3					
	90	Filtering time constant – input point 4					
	91	Filtering time constant – input point 5					
	92	Filtering time constant – input point 6					
	93	Filtering time constant – input point 7					
	94	Filtering time constant – input point 8					
	95	Filtering time constant – input point 9					
	96	Filtering time constant – input point 10					
	97	Filtering time constant – input point 11					
	98	Filtering time constant – input point 12					
	99	Filtering time constant – input point 13					
	100	Filtering time constant – input point 14					
	101	Filtering time constant – input point 15					
	102	Filtering time constant – input point 16					
	103	Averaging sample counts – input point 1					
	104	Averaging sample counts – input point 2					
	105	Averaging sample counts – input point 3					
	106	Averaging sample counts – input point 4					
	107	Averaging sample counts – input point 5					
	108	Averaging sample counts – input point 6					
	109	Averaging sample counts – input point 7					
	110	Averaging sample counts – input point 8					
	111	Averaging sample counts – input point 9					
	112	Averaging sample counts – input point 10					
	113	Averaging sample counts – input point 11					
	114	Averaging sample counts – input point 12					
	115	Averaging sample counts – input point 13					

DM word	Unit memory map	Function	Decimal value	Hex/BCD value			
	116	Averaging sample counts – input point 14					
	117	Averaging sample counts – input point 15					
	118	Averaging sample counts – input point 16					
	119	Scaling low limit – input point 1					
	120	Scaling high limit – input point 1					
	121	Scaling low limit – input point 2					
	122	Scaling high limit – input point 2					
	123	Scaling low limit – input point 3					
	124	Scaling high limit – input point 3					
	125	Scaling low limit – input point 4					
	126	Scaling high limit – input point 4					
	127	Scaling low limit – input point 5					
	128	Scaling high limit – input point 5					
	129	Scaling low limit – input point 6					
	130	Scaling high limit – input point 6					
	131	Scaling low limit – input point 7					
	132	Scaling high limit – input point 7					
	133	Scaling low limit – input point 8					
	134	Scaling high limit – input point 8					
	135	Scaling low limit – input point 9					
	136	Scaling high limit – input point 9					
	137	Scaling low limit – input point 10					
	138	Scaling high limit – input point 10					
	139	Scaling low limit – input point 11					
	140	Scaling high limit – input point 11					
	141	Scaling low limit – input point 12					
	142	Scaling high limit – input point 12					
	143	Scaling low limit – input point 13					
	144	Scaling high limit – input point 13					
	145	Scaling low limit – input point 14					
	146	Scaling high limit – input point 14					
	147	Scaling low limit – input point 15					
	148	Scaling high limit – input point 15					
	149	Scaling low limit – input point 16					
	150	Scaling high limit – input point 16					

C500-DA501 Analog Output Unit

Output Signal Range Settings

Enter circles in applicable cells.

Output point	Output signal range						Factory setting
	0 to 10 V	0 to 5 V	-5 to 5 V	-10 to 10 V	0 to 20 mA	4 to 20 mA	
1							0 to 10 V
2							
3							
4							
5							
6							
7							
8							

Output Signal Range Setting DIP Switch (on the Back of the Unit)

Settings

DIP switch pin No.		Output signal range						Factory setting
		0 to 10 V	0 to 5 V	-5 to 5 V	-10 to 10 V	0 to 20 mA	4 to 20 mA	0 to 10 V
1	4	ON	ON	ON	ON	OFF	OFF	ON
2	5	ON	ON	OFF	OFF	ON	ON	ON
3	6	OFF	ON	ON	OFF	OFF	ON	OFF

DIP Switches for Setting Voltage Output Ranges (on the Front of the Unit)

DIP switch pin No.	Voltage output	ON	OFF	Factory setting
4	-10 to 10 V	Enabled	Disabled	OFF
3	-5 to 5 V	Enabled	Disabled	OFF
2	0 to 10 V	Enabled	Disabled	ON
1	0 to 5 V	Enabled	Disabled	ON

- Note**
1. When a voltage output is set, set the same output signal range on the output signal range DIP switch and the voltage output range DIP switch.
 2. Outputs will not be correct if more than one DIP switch pin is turned ON. Turn ON only one of the pins shown above.
 3. When the output signal range is set to 4 to 20 mA or to 0 to 20 mA, the output will not be affected by the settings of these DIP switch pins.

DIP Switch Settings

Enter circles in applicable cells.

Output point	Pin	ON	OFF
Output point 1	1		
	2		
	3		
Output point 2	4		
	5		
	6		
Output point 3	1		
	2		
	3		
Output point 4	4		
	5		
	6		
Output point 5	1		
	2		
	3		
Output point 6	4		
	5		
	6		
Output point 7	1		
	2		
	3		
Output point 8	4		
	5		
	6		

RAM Data Memory Encoding Sheet

Word	Bit	Output point	Value	Name	Description	Data	Default
01	0 to 15	1		Conversion Data	Conversion source data for each output signal. Conversion data can be in either BCD or binary (set in bits 8 to 15 of address 14 in RAM). If the scaling function is disabled, conversion data is taken immediately before D/A conversion. If the scaling function is enabled, conversion data is in engineering units. (This data is scaled and then subject to D/A conversion.) If the upper/lower limit function is enabled, the upper and lower limits are written whenever values above the upper limit or below the lower limit are set.	With No Scaling BCD: 0 to 4095 (0000 to 4095 _{Hex}) or -2048 to 2048 (A048 to 2048 _{Hex}) Binary: 0000 to 0FFF _{Hex} or F800 to 07FF _{Hex} With Scaling BCD: -7999 to 7999 (F999 to 7999 _{Hex}) Binary: -32767 to 32767 (8001 to 7FFF _{Hex})	0000 _{Hex}
02	0 to 15	2					
03	0 to 15	3					
04	0 to 15	4					
05	0 to 15	5					
06	0 to 15	6					
07	0 to 15	7					
08	0 to 15	8					
12	0 to 15	---		Read Pointer	Specifies the leading RAM address from which data is to be read when the READ instruction is executed in the CPU Unit. It is set using the WRIT instruction with the number of words transferred set to 1.	0000 to 0061 (BCD)	0000 (BCD)
13	0	1		Scaling Enable Bits	Enables or disables the scaling function for each output point.	ON: Enabled OFF: Disabled	0
	1	2					
	2	3					
	3	4					
	4	5					
	5	6					
	6	7					
	7	8					
13	8	1		Output Ramp Enable Bits	Enables or disables the output ramp function for each output point.	ON: Enabled OFF: Disabled	0
	9	2					
	10	3					
	11	4					
	12	5					
	13	6					
	14	7					
	15	8					

Word	Bit	Output point	Value	Name	Description	Data	Default
14	0	1		Upper/Lower Limit Enable Bits	Enables or disables the upper/lower limit function for each output point.	ON: Enabled OFF: Disabled	0
	1	2					
	2	3					
	3	4					
	4	5					
	5	6					
	6	7					
	7	8					
	8	1		BCD/Binary Mode Bits	Specifies either BCD (1) or binary (0) data. The same data format is used for all settings for each output point. Conversion data: Addresses 01 to 08 Scaling upper and lower limits: Addresses 17 to 32 Output ramp set time: Addresses 33 to 40 Upper/lower limit function: Addresses 41 to 56	ON: BCD OFF: Binary	1
	9	2					
	10	3					
	11	4					
	12	5					
	13	6					
	14	7					
15	8						
15	0	1		Conversion Data Enable Bits	Enables or disables each output point. D/A conversion will be performed for only the enabled output points.	ON: Enabled OFF: Disabled	1
	1	2					
	2	3					
	3	4					
	4	5					
	5	6					
	6	7					
	7	8					
16	0 to 15	1 to 8		D/A Conversion Speed Mode Bits	Sets the D/A conversion speed mode for all output points.	0000 _{Hex} : Normal FFFF _{Hex} : High-speed	0000 _{Hex}

Word	Bit	Output point	Value	Name	Description	Data	Default
17	0 to 15	1		Scaling Lower Limit (Output Point 1)	Scaling lower limit for output point 1. Set in engineering units.	BCD: –7999 to 7999 (F999 to 7999 _{Hex}) Binary: –32767 to 32767 (8001 to 7FFF _{Hex})	Lower limit: 0000 _{Hex} Upper limit: 4095 _{Hex}
18	0 to 15			Scaling Upper Limit (Output Point 1)	Scaling upper limit for output point 1. Set in engineering units.		
19	0 to 15	2		Scaling Lower Limit (Output Point 2)	Scaling lower limit for output point 2. Set in engineering units.		
20	0 to 15			Scaling Upper Limit (Output Point 2)	Scaling upper limit for output point 2. Set in engineering units.		
21	0 to 15	3		Scaling Lower Limit (Output Point 3)	Scaling lower limit for output point 3. Set in engineering units.		
22	0 to 15			Scaling Upper Limit (Output Point 3)	Scaling upper limit for output point 3. Set in engineering units.		
23	0 to 15	4		Scaling Lower Limit (Output Point 4)	Scaling lower limit for output point 4. Set in engineering units.		
24	0 to 15			Scaling Upper Limit (Output Point 4)	Scaling upper limit for output point 4. Set in engineering units.		
25	0 to 15	5		Scaling Lower Limit (Output Point 5)	Scaling lower limit for output point 5. Set in engineering units.		
26	0 to 15			Scaling Upper Limit (Output Point 5)	Scaling upper limit for output point 5. Set in engineering units.		
27	0 to 15	6		Scaling Lower Limit (Output Point 6)	Scaling lower limit for output point 6. Set in engineering units.		
28	0 to 15			Scaling Upper Limit (Output Point 6)	Scaling upper limit for output point 6. Set in engineering units.		
29	0 to 15	7		Scaling Lower Limit (Output Point 7)	Scaling lower limit for output point 7. Set in engineering units.		
30	0 to 15			Scaling Upper Limit (Output Point 7)	Scaling upper limit for output point 7. Set in engineering units.		
31	0 to 15	8		Scaling Lower Limit (Output Point 8)	Scaling lower limit for output point 8. Set in engineering units.		
32	0 to 15			Scaling Upper Limit (Output Point 8)	Scaling upper limit for output point 8. Set in engineering units.		

Word	Bit	Output point	Value	Name	Description	Data	Default
33	0 to 15	1		Output Ramp Set Time (Output Point 1)	Output ramp set time for output point 1 (in ms). It must be 8 ms or more.	BCD: 8 to 7999 (0008 to 7999 _{Hex}) Binary: 8 to 32767 (0008 to 7FFF _{Hex})	0008 _{Hex}
34	0 to 15	2		Output Ramp Set Time (Output Point 2)	Output ramp set time for output point 2 (in ms). It must be 8 ms or more.		
35	0 to 15	3		Output Ramp Set Time (Output Point 3)	Output ramp set time for output point 3 (in ms). It must be 8 ms or more.		
36	0 to 15	4		Output Ramp Set Time (Output Point 4)	Output ramp set time for output point 4 (in ms). It must be 8 ms or more.		
37	0 to 15	5		Output Ramp Set Time (Output Point 5)	Output ramp set time for output point 5 (in ms). It must be 8 ms or more.		
38	0 to 15	6		Output Ramp Set Time (Output Point 6)	Output ramp set time for output point 6 (in ms). It must be 8 ms or more.		
39	0 to 15	7		Output Ramp Set Time (Output Point 7)	Output ramp set time for output point 7 (in ms). It must be 8 ms or more.		
40	0 to 15	8		Output Ramp Set Time (Output Point 8)	Output ramp set time for output point 8 (in ms). It must be 8 ms or more.		

Word	Bit	Output point	Value	Name	Description	Data	Default
41	0 to 15	1		Output Lower Limit (Output Point 1)	Output lower limit for output point 1. This is used to restrict the output signal range. When the scaling function is enabled, data is set in engineering units.	With No Scaling BCD: 0 to 4095 (0000 to 4095 _{Hex}) or –2048 to 2048 (A048 to 2048 _{Hex}) Binary: 0000 to 0FFF _{Hex} or F800 to 07FF _{Hex} With Scaling BCD: –7999 to 7999 (F999 to 7999 _{Hex}) Binary: –32767 to 32767 (8001 to 7FFF _{Hex})	Lower limit: 0000 _{Hex} Upper limit: 4095 _{Hex}
42	0 to 15			Output Upper Limit (Output Point 1)	Output upper limit for output point 1. This is used to restrict the output signal range. When the scaling function is enabled, data is set in engineering units.		
43	0 to 15	2		Output Lower Limit (Output Point 2)	Output lower limit for output point 2. This is used to restrict the output signal range. When the scaling function is enabled, data is set in engineering units.		
44	0 to 15			Output Upper Limit (Output Point 2)	Output upper limit for output point 2. This is used to restrict the output signal range. When the scaling function is enabled, data is set in engineering units.		
45	0 to 15	3		Output Lower Limit (Output Point 3)	Output lower limit for output point 3. This is used to restrict the output signal range. When the scaling function is enabled, data is set in engineering units.		
46	0 to 15			Output Upper Limit (Output Point 3)	Output upper limit for output point 3. This is used to restrict the output signal range. When the scaling function is enabled, data is set in engineering units.		
47	0 to 15	4		Output Lower Limit (Output Point 4)	Output lower limit for output point 4. This is used to restrict the output signal range. When the scaling function is enabled, data is set in engineering units.		
48	0 to 15			Output Upper Limit (Output Point 4)	Output upper limit for output point 4. This is used to restrict the output signal range. When the scaling function is enabled, data is set in engineering units.		

Word	Bit	Output point	Value	Name	Description	Data	Default
49	0 to 15	5		Output Lower Limit (Output Point 5)	Output lower limit for output point 5. This is used to restrict the output signal range. When the scaling function is enabled, data is set in engineering units.	With No Scaling BCD: 0 to 4095 (0000 to 4095 _{Hex}) or –2048 to 2048 (A048 to 2048 _{Hex}) Binary: 0000 to 0FFF _{Hex} or F800 to 07FF _{Hex} With Scaling BCD: –7999 to 7999 (F999 to 7999 _{Hex}) Binary: –32767 to 32767 (8001 to 7FFF _{Hex})	Lower limit: 0000 _{Hex} Upper limit: 4095 _{Hex}
50	0 to 15			Output Upper Limit (Output Point 5)	Output upper limit for output point 5. This is used to restrict the output signal range. When the scaling function is enabled, data is set in engineering units.		
51	0 to 15	6		Output Lower Limit (Output Point 6)	Output lower limit for output point 6. This is used to restrict the output signal range. When the scaling function is enabled, data is set in engineering units.		
52	0 to 15			Output Upper Limit (Output Point 6)	Output upper limit for output point 6. This is used to restrict the output signal range. When the scaling function is enabled, data is set in engineering units.		
53	0 to 15	7		Output Lower Limit (Output Point 7)	Output lower limit for output point 7. This is used to restrict the output signal range. When the scaling function is enabled, data is set in engineering units.		
54	0 to 15			Output Upper Limit (Output Point 7)	Output upper limit for output point 7. This is used to restrict the output signal range. When the scaling function is enabled, data is set in engineering units.		
55	0 to 15	8		Output Lower Limit (Output Point 8)	Output lower limit for output point 8. This is used to restrict the output signal range. When the scaling function is enabled, data is set in engineering units.		
56	0 to 15			Output Upper Limit (Output Point 8)	Output upper limit for output point 8. This is used to restrict the output signal range. When the scaling function is enabled, data is set in engineering units.		

Appendix B

Dimensions

All dimensions are in millimeters.

3G2A5-AD001 to 3G2A5-AD007 Analog Input Units
3G2A5-DA001 to 3G2A5-DA005 Analog Output Units
C500-DA101 and C500-DA103 Analog Output Units

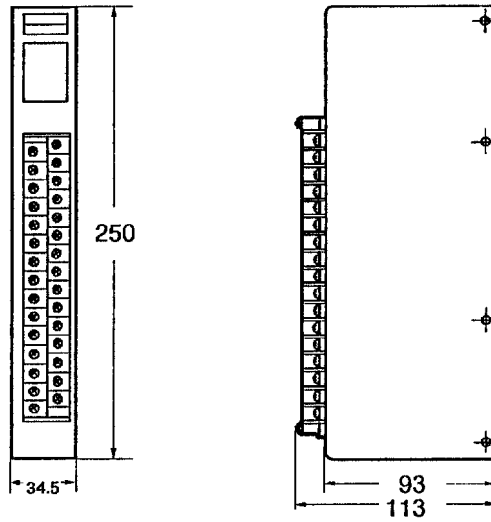

C500-AD101 Analog Input Unit

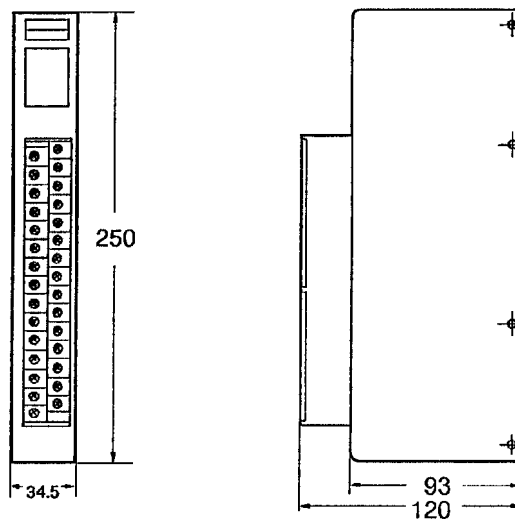

C500-AD501 Analog Input Unit
C500-DA501 Analog Output Unit

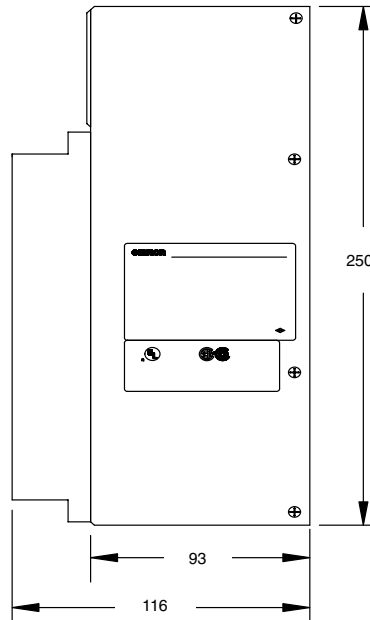
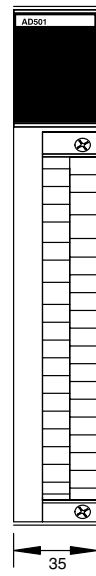

Index

A

alarms, C500-AD501, 79, 82, 83, 84, 85, 92, 101

allocations

See also memory allocations

DM, C500-AD101, 40

IR/CIO bits

3G2A5-AD001 to 3G2A5-AD005, 13

3G2A5-AD006 and 3G2A5-AD007, 23

3G2A5-DA001 to 3G2A5-DA005, 110

C500-AD101, 39, 50

C500-AD501, 78

C500-DA101, 122

C500-DA501, 163

C500-DA103, 132

averaging

See also mean value

C500-AD501, 83, 84, 86, 91, 103

B

bipolar inputs, 3G2A5-AD001 to 3G2A5-AD005, 14

bipolar outputs, 3G2A5-DA001 to 3G2A5-DA005, 111

block diagrams

3G2A5-AD001 to 3G2A5-AD005, 10

3G2A5-AD006 and 3G2A5-AD007, 20

3G2A5-DA001 to 3G2A5-DA005, 108

C500-AD101, 30

C500-AD501, 69

C500-DA101, 118

C500-DA501, 143

C500-DA103, 130

C

common mode input signals, 3G2A5-AD001 to 3G2A5-AD005, 11

configuration worksheets

C500-AD101, 193

C500-AD501, 194

C500-DA501, 198

DM memory, C500-AD101, 193

configurations, 5

servomotor positioning system, 6

temperature regulating system, 5

conversion data

3G2A5-DA001 to 3G2A5-DA005, 110

C500-DA101, 122

C500-DA103, 132

C500-DA501, 168

conversion errors, C500-DA501, 164, 166

conversion speed, C500-DA501, 164, 166, 169

converted data

3G2A5-AD001 to 3G2A5-AD005, 13

3G2A5-AD006 and 3G2A5-AD007, 23

C500-AD101, 42, 51

C500-AD501, 82

CPU Unit, communications

C500-AD101, 37, 50

C500-AD501, 76

C500-DA501, 145, 153

current inputs

3G2A5-AD001 to 3G2A5-AD005, 11

3G2A5-AD006 and 3G2A5-AD007, 21

C500-AD101, 37

data conversion, C500-AD101, 32

current outputs

3G2A5-DA001 to 3G2A5-DA005, 109

C500-DA501, 140

C500-DA101, 120

D

data coding. *See* configuration worksheets

data conversion

3G2A5-AD001 to 3G2A5-AD005, 14

3G2A5-DA001 to 3G2A5-DA005, 110

3G2A5-AD006 and 3G2A5-AD007, 23

C500-AD101, 32

C500-AD501, 63

C500-DA101, 123

C500-DA501, 139

C500-DA103, 132

enabling, C500-DA501, 168, 169

data format

BCD or binary

C500-AD501, 64, 84

C500-DA501, 140

selection

C500-AD501, 83

C500-DA501, 167, 168, 169, 175

differential output signals, 3G2A5-AD001 to 3G2A5-AD005, 11, 12

dimensions, 207

DIP switches, C500-DA501, 147

disconnection detection, C500-AD101, 32, 42, 51

DM allocation, C500-AD101, 40

data reading area, 41, 42

data writing area, 40

E

EEPROM

C500-AD501, 79, 86, 93

C500-DA501, 163, 165, 174, 190

error flags

- C500-AD501, 79, 80
- C500-DA501, 164, 166, 168, 174, 175
- no error flags, C500-DA501, 164, 166

F

features

- Analog Input Units, 2
- Analog Output Units, 3

filtering, C500-AD501, 83, 84, 85, 91, 102

functions

- See also* features
- C500-AD101, 32
- C500-AD501, 65, 87
- C500-DA501, 141, 175

I

I/O READ and I/O WRITE instructions

- C500-AD101, 37
- C500-AD501, 76, 94
- C500-DA501, 145, 153, 155, 156

indicators

- C500-AD501, 67
- C500-DA501, 142

input point specification

- C500-AD101, 41, 51
- C500-AD501, 83, 84

input ranges, 2, 3

- error flags, C500-AD501, 82
- errors, C500-AD501, 79
- settings
 - C500-AD101, 34
 - C500-AD501, 70

internal structure, C500-DA501, 144

invalid data, C500-DA501, 166, 168, 173, 174

L

ladder programming

- C500-DA501, 157, 161
- examples
 - 3G2A5-AD001 to 3G2A5-AD005, 15
 - 3G2A5-AD006 and 3G2A5-AD007, 24
 - 3G2A5-DA001 to 3G2A5-DA005, 112
 - C500-AD101, 43, 51
 - C500-DA101, 124
 - C500-AD501, 94, 100
 - C500-DA501, 182
 - C500-DA103, 133

M

mean value

- See also* averaging
- C500-AD101, 32, 41, 51

memory allocations

- See also* allocations
- 3G2A5-AD001 to 3G2A5-AD005, 13
- 3G2A5-AD006 and 3G2A5-AD007, 23
- 3G2A5-DA001 to 3G2A5-DA005, 110
- C500-AD101
 - four-word operation, 50
 - two-word operation, 39
- C500-AD501, 78
- C500-DA101, 122
- C500-DA501, 163
- C500-DA103, 132

memory map

- C500-AD501, 80
- C500-DA501, 145, 167

O

operation

- C500-AD101, 31, 33
- C500-DA501, 146, 149, 154
- C500-DA101, 123

output ramps, C500-DA501, 141, 168, 169, 171, 177

output ranges, 2, 4

- 3G2A5-DA001 to 3G2A5-DA005, 110
- enabling limits, C500-DA501, 169
- errors, C500-DA501, 164
- limits, 168
 - C500-DA501, 166, 172, 173, 179
- settings
 - C500-DA101, 119
 - C500-DA501, 147

P

parameters, updating, C500-DA501, 163, 165

parts, description

- 3G2A5-AD001 to 3G2A5-AD005, 9
- 3G2A5-AD006 and 3G2A5-AD007, 19
- 3G2A5-DA001 to 3G2A5-DA005, 107
- C500-AD101, 29
- C500-AD501, 66
- C500-DA101, 117
- C500-DA501, 142
- C500-DA103, 129

PC write delay

- 3G2A5-AD001 to 3G2A5-AD005, 9
- 3G2A5-AD006 and 3G2A5-AD007, 18

peak hold

- C500-AD101, 32, 39, 51
- C500-AD501, 79, 83, 84, 92

pointer word
 C500-AD501, 84, 95
 C500-DA501, 165, 169

power consumption, C500-AD501, 70

power supply, flag, C500-DA501, 164, 166

precautions
 applications, xvii
 averaging and alarms, C500-AD501, 88
 C500-AD101
 mean values, 41
 scaling, 42
 general, xv, xvi
 operating environment, xvii
 programming, C500-DA501, 188
 safety, xvi
 system configuration, 6
 wiring, 6
 3G2A5-AD001 to 3G2A5-AD005, 12, 13
 3G2A5-AD006 and 3G2A5-AD007, 22
 3G2A5-DA001 to 3G2A5-DA005, 109
 C500-DA101, 120
 C500-AD501, 75
 C500-DA501, 152
 C500-DA103, 131

programming. *See* ladder programming

pulse signals, applications, C500-DA501, 189

R

reading data
 automatic, C500-DA501, 166
 C500-AD101, 41, 42
 C500-AD501, 98
 C500-DA501, 161, 183, 187
 completing, C500-DA501, 165, 166
 requesting read/write, C500-DA501, 165

S

scaling
 C500-AD101, 33, 42
 C500-AD501, 83, 84, 86, 88, 100
 C500-DA501, 168, 169, 170, 175

serial port, enabling, C500-AD501, 79

servomotor positioning system, 6

specifications
 general
 3G2A5-AD001 to 3G2A5-AD005, 8
 3G2A5-AD006 and 3G2A5-AD007, 18
 3G2A5-DA001 to 3G2A5-DA005, 106
 C500-AD101, 28
 C500-AD501, 62
 C500-DA101, 116
 C500-DA501, 136
 C500-DA103, 128
 input, C500-AD501, 63
 output, C500-DA501, 139

performance
 3G2A5-AD001 to 3G2A5-AD005, 8
 3G2A5-AD006 and 3G2A5-AD007, 18
 3G2A5-DA001 to 3G2A5-DA005, 106
 C500-AD101, 28
 C500-AD501, 62
 C500-DA101, 116
 C500-DA501, 136
 C500-DA103, 128

switch settings
 C500-AD101, 34
 input ranges, 35
 C500-AD501, 68
 input ranges, 70
 C500-DA501, 150
 output ranges, 147

T

temperature regulating system, 5

terminal connections
 C500-AD101, 36
 C500-DA501, 151
 C500-DA101, 120
 C500-DA103, 131

U

unconfirmed data, C500-AD101, 39

unipolar inputs
 3G2A5-AD001 to 3G2A5-AD005, 14
 3G2A5-AD006 and 3G2A5-AD007, 23

unipolar outputs, 3G2A5-DA001 to 3G2A5-DA005, 110

Unit locations
 C500-AD501, 70
 C500-DA501, 149

V

voltage inputs
 3G2A5-AD001 to 3G2A5-AD005, 11, 12
 3G2A5-AD006 and 3G2A5-AD007, 21
 C500-AD101, 36
 data conversion, C500-AD101, 32

voltage outputs
 3G2A5-DA001 to 3G2A5-DA005, 109
 C500-DA501, 139
 C500-DA101, 120
 C500-DA103, 131

W

wiring
 C500-AD501, 72
 C500-DA501, 151

current inputs
 3G2A5-AD001 to 3G2A5-AD005, 11, 13
 3G2A5-AD006 and 3G2A5-AD007, 21
 C500-AD101, 37

- current outputs
 - 3G2A5-DA001 to 3G2A5-DA005, 109
 - C500-DA101, 120
- diagrams, C500-AD501, 73
- precautions
 - 3G2A5-AD001 to 3G2A5-AD005, 12, 13
 - 3G2A5-AD006 and 3G2A5-AD007, 22
 - 3G2A5-DA001 to 3G2A5-DA005, 109
 - C500-DA101, 120
 - C500-AD501, 75
 - C500-DA501, 152
 - C500-DA103, 131
- terminal connections
 - C500-AD101, 36
 - C500-DA101, 120
 - C500-DA103, 131
- voltage inputs
 - 3G2A5-AD001 to 3G2A5-AD005, 11
 - 3G2A5-AD006 and 3G2A5-AD007, 21
 - C500-AD101, 36
- voltage outputs
 - 3G2A5-DA001 to 3G2A5-DA005, 109
 - C500-DA101, 120
 - C500-DA103, 131
- writing data
 - C500-AD101, 40
 - C500-AD501, 95
 - C500-DA501, 160, 182, 184
 - completing, C500-DA501, 165, 166
 - requesting read/write, C500-DA501, 165
 - setting contents, C500-AD101, 41

Revision History

A manual revision code appears as a suffix to the catalog number on the front cover of the manual.

Cat. No. W258-E1-05

The following table outlines the changes made to the manual during each revision. Page numbers refer to the previous version.

Revision code	Date	Revised content
1	July 1995	Original production
1A	December 1995	Page 49: Last two lines of the program corrected.
2	July 1999	C500-AD501 Analog Input Unit added (from W259) to section 1, as a new section, section 5, and to the appendices. C500-DA501 Analog Output Unit added to section 1, as a new section, section 9, and to the appendices. Modified terminology to agree with other manuals. Added PLP section. Added two appendices. Page 6 and 33: Corrected wording of cautions on Slave Racks. Page 32: Added information on disconnection detection. Page 38: Added information on restrictions for READ/WRITE.
3	July 2001	The insert providing precautionary information was moved to pages 105 and 116. In addition, the following changes were made. Page xiii: Minor change to wording of <i>Application Precautions</i> . Pages 53 and 57: Changes made to ladder diagrams. Page 75: Information added to step 5. Page 77, 156, and 157: Changes made to tables. Page 94: Note added and changes made to ladder diagram. Page 149: Information added after first paragraph. Page 152: Changes made to ladder programs. Page 170: Note added.

Revision History

Revision code	Date	Revised content
04	April 2003	<p>The following changes were made.</p> <p>Page 30: Callouts changed.</p> <p>Page 53: Program concept diagram and timing chart added.</p> <p>Page 91: Item 0 for 152 removed from table and item 5 removed from list.</p> <p>Page 172: Data changed for word 60.</p> <p>Page 189: Bit 00 removed from table.</p>
05	August 2007	<p>The following changes were made to reflect changes in C500-AD501 and C500-DA501 specifications.</p> <p>Page xi: Added <i>Warranty and Limitations of Liability</i>.</p> <p>Page xiv: Added <i>Conformance to EC Directives</i>.</p> <p>Page 62: Updated information for the input signal ranges and added notes below the table.</p> <p>Page 66: Replaced the figures.</p> <p>Page 67: Deleted the top paragraph, modified the table, and replaced the figures.</p> <p>Page 68: Modified the text and replaced the figures.</p> <p>Page 69: Replaced the figures.</p> <p>Pages 70 and 71: Modified the texts, tables and figures.</p> <p>Page 72: Replaced the figures.</p> <p>Page 138: Updated information on the output signals when PC is turned OFF.</p> <p>Pages 142 and 143: Replaced the figures and modified the table.</p> <p>Pages 147, 148, 149, and 150: Modified the texts, tables, and figures.</p> <p>Page 194: Added information on input signal range settings.</p> <p>Page 197: Modified information on the output signal range setting DIP switch.</p>

Terms and Conditions of Sale

- Offer; Acceptance.** These terms and conditions (these "Terms") are deemed part of all quotes, agreements, purchase orders, acknowledgments, price lists, catalogs, manuals, brochures and other documents, whether electronic or in writing, relating to the sale of products or services (collectively, the "Products") by Omron Electronics LLC and its subsidiary companies ("Omron"). Omron objects to any terms or conditions proposed in Buyer's purchase order or other documents which are inconsistent with, or in addition to, these Terms.
- Prices; Payment Terms.** All prices stated are current, subject to change without notice by Omron. Omron reserves the right to increase or decrease prices on any unshipped portions of outstanding orders. Payments for Products are due net 30 days unless otherwise stated in the invoice.
- Discounts.** Cash discounts, if any, will apply only on the net amount of invoices sent to Buyer after deducting transportation charges, taxes and duties, and will be allowed only if (i) the invoice is paid according to Omron's payment terms and (ii) Buyer has no past due amounts.
- Interest.** Omron, at its option, may charge Buyer 1-1/2% interest per month or the maximum legal rate, whichever is less, on any balance not paid within the stated terms.
- Orders.** Omron will accept no order less than \$200 net billing.
- Governmental Approvals.** Buyer shall be responsible for, and shall bear all costs involved in, obtaining any government approvals required for the importation or sale of the Products.
- Taxes.** All taxes, duties and other governmental charges (other than general real property and income taxes), including any interest or penalties thereon, imposed directly or indirectly on Omron or required to be collected directly or indirectly by Omron for the manufacture, production, sale, delivery, importation, consumption or use of the Products sold hereunder (including customs duties and sales, excise, use, turnover and license taxes) shall be charged to and remitted by Buyer to Omron.
- Financial.** If the financial position of Buyer at any time becomes unsatisfactory to Omron, Omron reserves the right to stop shipments or require satisfactory security or payment in advance. If Buyer fails to make payment or otherwise comply with these Terms or any related agreement, Omron may (without liability and in addition to other remedies) cancel any unshipped portion of Products sold hereunder and stop any Products in transit until Buyer pays all amounts, including amounts payable hereunder, whether or not then due, which are owing to it by Buyer. Buyer shall in any event remain liable for all unpaid accounts.
- Cancellation; Etc.** Orders are not subject to rescheduling or cancellation unless Buyer indemnifies Omron against all related costs or expenses.
- Force Majeure.** Omron shall not be liable for any delay or failure in delivery resulting from causes beyond its control, including earthquakes, fires, floods, strikes or other labor disputes, shortage of labor or materials, accidents to machinery, acts of sabotage, riots, delay in or lack of transportation or the requirements of any government authority.
- Shipping; Delivery.** Unless otherwise expressly agreed in writing by Omron:
 - Shipments shall be by a carrier selected by Omron; Omron will not drop ship except in "break down" situations.
 - Such carrier shall act as the agent of Buyer and delivery to such carrier shall constitute delivery to Buyer;
 - All sales and shipments of Products shall be FOB shipping point (unless otherwise stated in writing by Omron), at which point title and risk of loss shall pass from Omron to Buyer; provided that Omron shall retain a security interest in the Products until the full purchase price is paid;
 - Delivery and shipping dates are estimates only; and
 - Omron will package Products as it deems proper for protection against normal handling and extra charges apply to special conditions.
- Claims.** Any claim by Buyer against Omron for shortage or damage to the Products occurring before delivery to the carrier must be presented in writing to Omron within 30 days of receipt of shipment and include the original transportation bill signed by the carrier noting that the carrier received the Products from Omron in the condition claimed.
- Warranties.** (a) **Exclusive Warranty.** Omron's exclusive warranty is that the Products will be free from defects in materials and workmanship for a period of twelve months from the date of sale by Omron (or such other period expressed in writing by Omron). Omron disclaims all other warranties, express or implied. (b) **Limitations.** OMRON MAKES NO WARRANTY OR REPRESENTATION, EXPRESS OR IMPLIED, ABOUT NON-INFRINGEMENT, MERCHANTABILITY OR FITNESS FOR A PARTICULAR PURPOSE OF THE PRODUCTS. BUYER ACKNOWLEDGES THAT IT ALONE HAS DETERMINED THAT THE PRODUCTS WILL SUITABLY MEET THE REQUIREMENTS OF THEIR INTENDED USE. Omron further disclaims all warranties and responsibility of any type for claims or expenses based on infringement by the Products or otherwise of any intellectual property right. (c) **Buyer Remedy.** Omron's sole obligation hereunder shall be, at Omron's election, to (i) replace (in the form originally shipped with Buyer responsible for labor charges for removal or replacement thereof) the non-complying Product, (ii) repair the non-complying Product, or (iii) repay or credit Buyer an amount equal to the purchase price of the non-complying Product; provided that in no event shall Omron be responsible for warranty, repair, indemnity or any other claims or expenses regarding the Products unless Omron's analysis confirms that the Products were properly handled, stored, installed and maintained and not subject to contamination, abuse, misuse or inappropriate modification. Return of any Products by Buyer must be approved in writing by Omron before shipment. Omron Companies shall not be liable for the suitability or unsuitability or the results from the use of Products in combination with any electrical or electronic components, circuits, system assemblies or any other materials or substances or environments. Any advice, recommendations or information given orally or in writing, are not to be construed as an amendment or addition to the above warranty. See <http://www.omron247.com> or contact your Omron representative for published information.
- Limitation on Liability; Etc.** OMRON COMPANIES SHALL NOT BE LIABLE FOR SPECIAL, INDIRECT, INCIDENTAL, OR CONSEQUENTIAL DAMAGES, LOSS OF PROFITS OR PRODUCTION OR COMMERCIAL LOSS IN ANY WAY CONNECTED WITH THE PRODUCTS, WHETHER SUCH CLAIM IS BASED IN CONTRACT, WARRANTY, NEGLIGENCE OR STRICT LIABILITY. Further, in no event shall liability of Omron Companies exceed the individual price of the Product on which liability is asserted.
- Indemnities.** Buyer shall indemnify and hold harmless Omron Companies and their employees from and against all liabilities, losses, claims, costs and expenses (including attorney's fees and expenses) related to any claim, investigation, litigation or proceeding (whether or not Omron is a party) which arises or is alleged to arise from Buyer's acts or omissions under these Terms or in any way with respect to the Products. Without limiting the foregoing, Buyer (at its own expense) shall indemnify and hold harmless Omron and defend or settle any action brought against such Companies to the extent based on a claim that any Product made to Buyer specifications infringed intellectual property rights of another party.
- Property; Confidentiality.** Any intellectual property in the Products is the exclusive property of Omron Companies and Buyer shall not attempt to duplicate it in any way without the written permission of Omron. Notwithstanding any charges to Buyer for engineering or tooling, all engineering and tooling shall remain the exclusive property of Omron. All information and materials supplied by Omron to Buyer relating to the Products are confidential and proprietary, and Buyer shall limit distribution thereof to its trusted employees and strictly prevent disclosure to any third party.
- Export Controls.** Buyer shall comply with all applicable laws, regulations and licenses regarding (i) export of products or information; (ii) sale of products to "forbidden" or other proscribed persons; and (iii) disclosure to non-citizens of regulated technology or information.
- Miscellaneous.** (a) **Waiver.** No failure or delay by Omron in exercising any right and no course of dealing between Buyer and Omron shall operate as a waiver of rights by Omron. (b) **Assignment.** Buyer may not assign its rights hereunder without Omron's written consent. (c) **Law.** These Terms are governed by the law of the jurisdiction of the home office of the Omron company from which Buyer is purchasing the Products (without regard to conflict of law principles). (d) **Amendment.** These Terms constitute the entire agreement between Buyer and Omron relating to the Products, and no provision may be changed or waived unless in writing signed by the parties. (e) **Severability.** If any provision hereof is rendered ineffective or invalid, such provision shall not invalidate any other provision. (f) **Setoff.** Buyer shall have no right to set off any amounts against the amount owing in respect of this invoice. (g) **Definitions.** As used herein, "including" means "including without limitation"; and "Omron Companies" (or similar words) mean Omron Corporation and any direct or indirect subsidiary or affiliate thereof.

Certain Precautions on Specifications and Use

- Suitability of Use.** Omron Companies shall not be responsible for conformity with any standards, codes or regulations which apply to the combination of the Product in the Buyer's application or use of the Product. At Buyer's request, Omron will provide applicable third party certification documents identifying ratings and limitations of use which apply to the Product. This information by itself is not sufficient for a complete determination of the suitability of the Product in combination with the end product, machine, system, or other application or use. Buyer shall be solely responsible for determining appropriateness of the particular Product with respect to Buyer's application, product or system. Buyer shall take application responsibility in all cases but the following is a non-exhaustive list of applications for which particular attention must be given:
 - Outdoor use, uses involving potential chemical contamination or electrical interference, or conditions or uses not described in this document.
 - Use in consumer products or any use in significant quantities.
 - Energy control systems, combustion systems, railroad systems, aviation systems, medical equipment, amusement machines, vehicles, safety equipment, and installations subject to separate industry or government regulations.
 - Systems, machines and equipment that could present a risk to life or property. Please know and observe all prohibitions of use applicable to this Product.

NEVER USE THE PRODUCT FOR AN APPLICATION INVOLVING SERIOUS RISK TO LIFE OR PROPERTY OR IN LARGE QUANTITIES WITHOUT ENSURING THAT THE SYSTEM AS A WHOLE HAS BEEN DESIGNED TO
- ADDRESS THE RISKS, AND THAT THE OMRON'S PRODUCT IS PROPERLY RATED AND INSTALLED FOR THE INTENDED USE WITHIN THE OVERALL EQUIPMENT OR SYSTEM.
- Programmable Products.** Omron Companies shall not be responsible for the user's programming of a programmable Product, or any consequence thereof.
- Performance Data.** Data presented in Omron Company websites, catalogs and other materials is provided as a guide for the user in determining suitability and does not constitute a warranty. It may represent the result of Omron's test conditions, and the user must correlate it to actual application requirements. Actual performance is subject to the Omron's Warranty and Limitations of Liability.
- Change in Specifications.** Product specifications and accessories may be changed at any time based on improvements and other reasons. It is our practice to change part numbers when published ratings or features are changed, or when significant construction changes are made. However, some specifications of the Product may be changed without any notice. When in doubt, special part numbers may be assigned to fix or establish key specifications for your application. Please consult with your Omron's representative at any time to confirm actual specifications of purchased Product.
- Errors and Omissions.** Information presented by Omron Companies has been checked and is believed to be accurate; however, no responsibility is assumed for clerical, typographical or proofreading errors or omissions.



OMRON ELECTRONICS LLC

1 Commerce Drive
Schaumburg, IL 60173
847.843.7900
For US technical support or
other inquiries: 800.556.6766

OMRON CANADA, INC.

885 Milner Avenue
Toronto, Ontario M1B 5V8
416.286.6465

OMRON ON-LINE

Global - www.omron.com
USA - www.omron247.com
Canada - www.omron.ca
Brazil - www.omron.com.br
Latin America - www.espanol.omron.com

UNITED STATES

To locate a Regional Sales Office, local Distributor or
to obtain product information, call: 847.843.7900

MEXICO SALES OFFICES

Mexico, D.F.	555.660.3144
Ciudad Juárez	656.623.7083
Monterrey, N.L.	818.377.4281
Querétaro	442.135.4510

BRAZIL SALES OFFICE

Sao Paulo	55.11.2101.6310
-----------	-----------------

ARGENTINA SALES OFFICE

Cono Sur	54.114.787.1129
----------	-----------------

OTHER LATIN AMERICAN SALES

mela@omron.com