

Contents

CX-Automation Suite	E-2
CX-Server Runtime	E-3
CX-Programmer	E-4
CX-Simulator	E-9
CX-Protocol	E-10
CX-Motion	E-11
CX-Position	E-12
CX-Supervisor	E-13
CX-ServerLITE	E-14
CX-ServerOPC	E-15
Hand-Held Programmings	E-16
Cables and Connection Diagrams	E-18

Easy-to-use Software and Programming Tools

Shorten setup and diagnostic time with powerful software from Omron's CX-Automation suite. Design custom HMI projects to match production. Use hand-held programmers as compact, efficient troubleshooting tools.



One Package Programs Most PLCs

- Learn to program just once
- Same look and feel to programs for micros to large rack systems
- More efficient: uses fewer programming steps than competitors
- Flexible instruction set substitutes application-specific ones for unused ones
- Easy to upgrade field installations

Easy Migration Among PLC Platforms

- Responsive to changing needs in hardware to handle more I/O or faster processing
- Programming migrates using a conversion utility built into CX-Programmer
- Omron engineering support assures smooth transition—full menu of services available to jump-start your productivity
- Compact Flash memory cards simplify transfer of programs, recipes among PLCs

Design Custom HMI Projects

- Complete CX-Supervisor package for fast, efficient graphic design of projects
- Extensive library of graphics and symbols with drag-and-drop screen development
- CX-ServerLITE offers ActiveX control to exchange data with Omron PLCs and industrial PCs
- CX-ServerOPC provides OPC client/server support for legacy third-party HMI systems



CX-Automation Suite

This section describes the software available for programming, communicating with and performing data collection with Omron programmable controllers.

Hand-held programmers provide a compact alternative to a laptop computer for plant floor diagnostics and testing.

Programming an Omron controller?	Choose CX-Programmer Software	Page E-4
Can't physically hook up an Omron controller to test programs?	Choose CX-Simulator Software	Page E-9
Using serial communications and need to get a serial device to exchange data with the PLC?	Use CX-Protocol software to develop serial device protocols	Page E-10
Setting up and programming MC series motion modules?	Choose CX-Motion	Page E-11
Want to shorten setup for single- and multi-axis position control?	Choose CX-Position	Page E-12
Designing a full-featured PC-based HMI for automation equipment?	Choose CX-Supervisor	Page E-13
Need an ActiveX control for Omron controllers?	Choose CX-ServerLITE	Page E-14
Need an OPC server for Omron products?	Choose CX-ServerOPC	Page E-15
Need a hand-held programmer for plant floor diagnostics and debugging?	Choose CQM1H-PRO01-E or C200H-PRO27-E	Page E-16
Need cables to connect Omron PLCs to PCs for programming, networking, and HMI; also connecting operator interface terminals?	Using serial port Using peripheral port Connection diagrams	Page E-18

Overview

Omron continues to expand its growing family of software products for programming, communications, and data collection to interface with our full line of programmable controllers. CX-Automation Suite is Omron's family of software products that maximize productivity, simplifying the already easy to use Omron industrial automation products.

- Suite products use Omron's CX-Server for powerful and reliable communications
- Support all Omron communication protocols
- All programs have a common look and feel
- Develop a single I/O point (tag) database for your PLC program using CX-Programmer and import it directly to CX-Supervisor or other CX-Automation Suite products

CX-Automation Suite Software Packages

For detailed descriptions of functionality, review the individual data sheet or manual for each product. Visit Omron's Knowledge Center at www.knowledge.omron.com, select Programmable Logic Controllers, then search for documentation by the literature number in the right-hand column.

Software Package	Function	Literature
CX-Programmer	Program development tool for Omron PLCs	W425
CX-Simulator	Virtual PLC for program testing/debugging	W366
CX-Protocol	Serial protocol development tool for use with Omron serial modules	W344
CX-Motion	Programming/monitoring for single or multi-axis MC motion modules	N/A
CX-Position	Programming/monitoring for single or multi-axis NC Positioning modules	W398
CX-Supervisor	Full featured PC-based HMI for Microsoft® Windows®	DS04P1
CX-ServerLITE	ActiveX control for all Omron communication protocols	DS10P1
CX-ServerOPC	OPC Server for all Omron controllers	DS09P1

CX-Automation Suite Architecture

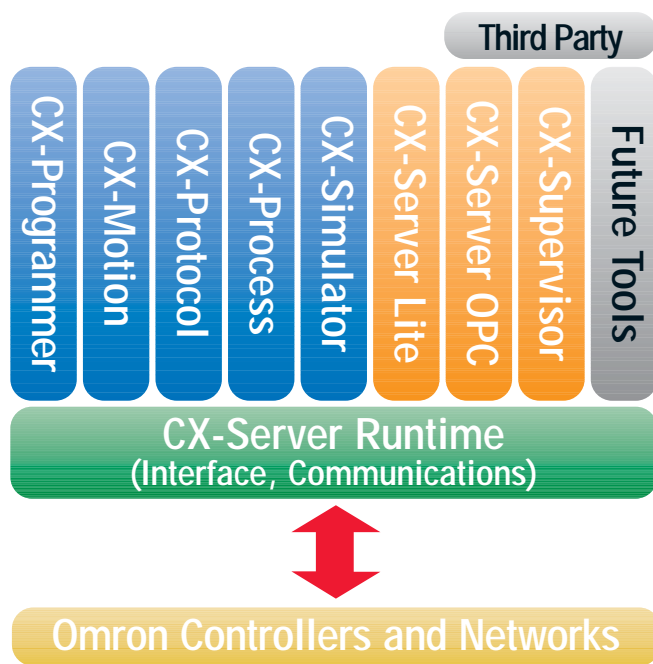

CX-Server Runtime

At the core of Omron's CX-Automation Suite is CX-Server Runtime, a common framework that all suite products use and share. A solid piece of middleware built on a Windows® 32-bit platform, CX-Server Runtime.

- Supports all Omron communication protocols
- Shares a common I/O point database between suite products
- Includes diagnostic tools to aid in installing and using Omron control components.

CX-Server Runtime makes setting up communications easy, using a Windows Explorer® style Smart Configurator: Choose controller types, communication networks and assign I/O points, and the configurator takes care of the rest. I/O points can also be imported/exported using Microsoft® Excel. An entire network of Omron controllers can be configured for communications and data exchange in no time at all.

CX-Server Runtime includes all the Omron communication protocols: Toolbus, Host Link (SYSMAC Way), SYSMAC Net, SYSMAC Link, Controller Link, Ethernet, and can act as a gateway to FINS. It also offers a dynamic data exchange (DDE) Client/Server, and diagnostic tools such as the "Performance Monitor" which displays communication throughput usage to assist in network optimization.

CX-Programmer

*Enhanced Design and
Development Environment*



■ Applications

Omron's CX-Programmer makes working with an Omron PLC so easy.

With CX-Programmer, You Can Do All This and More

- Develop, write, modify and debug programs online/offline
- Import and upgrade existing legacy programs (used in older Omron programming packages) using the file conversion utility
- Set up hardware
- Set up and perform communications
- Set up PLC networks
- Perform diagnostics, testing and debugging
- Monitor data and networks
- Generate reports
- Share tag data with other CX-Automation Suite products

One software tool for ALL Omron PLCs, CX-Programmer is the only software program needed.

CX-Programmer structure offers flexibility in managing programs. It's Windows Explorer® style interface makes the task of creating logic programs easy. Multiple window displays, tree style overviews, "watch and output" windows, and standard Windows® menus all help to make it simple and intuitive to use.

It's packed with powerful features like support for legacy Omron programming software – you can import PLC programs created in SYSWIN, CPT, SSS, CVSS, and LSS directly; perform advanced diagnostics; you can *trace data* and run *timing charts* or set up network routing tables and much more.

■ Key Features

- Program all Omron Controllers and support network setup in one package
- Programming software is compatible with Windows® 95/98/NT4.0 Systems 2000/XP
- Built-in CX-Net and CX-Server network configuration utilities simplify communications between PLCs and PCs

■ Ordering Information

Product Description	Version Type	Language Support	Operating System	Model Number
CX-Programmer, single license	Full version	English, Japanese, Chinese (PRC)	WIN XPPro, 2KPro, NT4.0 (sp 3+), 95, 98	WS02-CXPC1-E-V□.□
CX-Programmer, 3-pack license	Full version	English, Japanese, Chinese (PRC)	WIN XPPro, 2KPro, NT4.0 (sp 3+), 95, 98	WS02-CXPC1-E03-V□.□
CX-Programmer, 10-pack license	Full version	English, Japanese, Chinese (PRC)	WIN XPPro, 2KPro, NT4.0 (sp 3+), 95, 98	WS02-CXPC1-E10-V□.□
CX-Programmer Junior,* single license	Full version	English, Japanese, Chinese (PRC)	WIN XPPro, 2KPro, NT4.0 (sp 3+), 95, 98	WS02-CXPC1-EJ-V□.□
CX-Programmer, single license	Upgrade version	English, Japanese, Chinese (PRC)	WIN XPPro, 2KPro, NT4.0 (sp 3+), 95, 98	WS02-CXPC1-EUP-V□.□
CX-Programmer, 3-pack license	Upgrade version	English, Japanese, Chinese (PRC)	WIN XPPro, 2KPro, NT4.0 (sp 3+), 95, 98	WS02-CXPC1-EUP03-V□.□
CX-Programmer, 10-pack license	Upgrade version	English, Japanese, Chinese (PRC)	WIN XPPro, 2KPro, NT4.0 (sp 3+), 95, 98	WS02-CXPC1-EUP10-V□.□
CX-Programmer Junior,* single license	Upgrade version	English, Japanese, Chinese (PRC)	WIN XPPro, 2KPro, NT4.0 (sp 3+), 95, 98	WS02-CXPC1-EUPJ-V□.□
CX-Programmer, All version 3 users, no license	Upgrade version	English, Japanese, Chinese (PRC)	WIN XPPro, 2KPro, NT4.0 (sp 3+), 95, 98	WS02-CXPC1-EUPL-V□.□**

*Note: CX-Programmer Junior support for Omron micro PLC line only CPM1 (CPM1A), CPM2□ (All, except CPM2C-S), SRM1, SRM1-V2

**Note: Available in Canada only.

CX-Programmer

Provides a Wealth of Functionality in an Efficient and Intuitive Environment

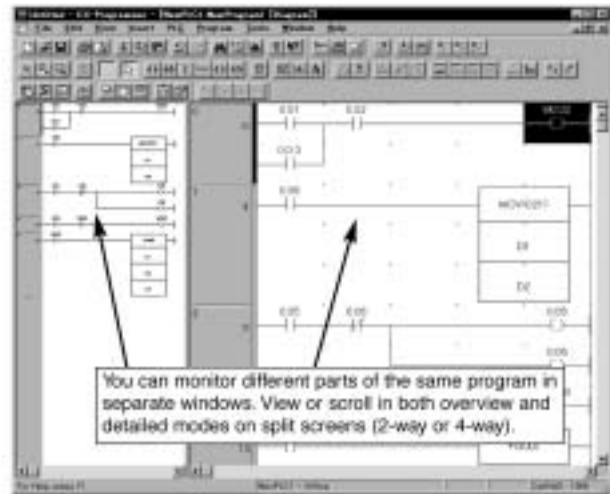
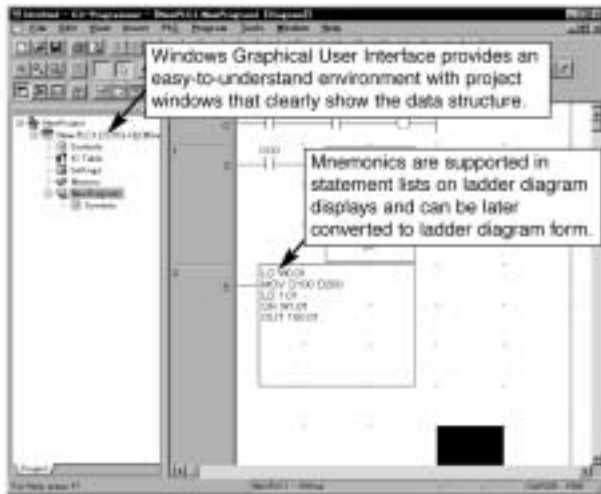

■ Easy Operation

- Operations with mouse or function keys.
- Windows Explorer® style interface.
- Advanced Find/Replace functions.
- Display operand input ranges.
- Convert text inputs to ladder diagrams. Either enter mnemonics into ladder diagram displays or convert text from text editors.
- Copy/paste I/O data to and from MS Excel® for creation/editing.

■ Numerous Display and Monitoring Options

- Monitor present values of specified addresses.
- Watch Windows enable monitoring of specific address locations.
- Output Windows can display: errors, search results, file read errors, and program comparison results.

■ Data Compatibility with Windows Applications

- Import I/O table data such as name, address, and I/O comments from Microsoft® Excel spreadsheets.

■ Flexible Maintenance Functions

- Force-setting/resetting.
- Differential monitoring.
- Timer/Counter set value changes.
- Cross-references.
- Data trace and time chart monitoring.
- Online editing of multiple locations and controllers.
- Online editing of different tasks from different computers.

■ Remote Programming and Monitoring

- Access any PLC located on a network from a single location (single port multiple access).
- Access remote PLCs via modem connections.
- Store/read CPU data (programs, parameters, memory contents, or comments) in memory files on optional Flash memory cards or built-in data file (EM) file memory.
- Display time-stamped error histories (including user-generated error logs) from the CPU.
- Protect programs for access using passwords.

CX-Programmer

■ Import/Export I/O Allocations, Comments and Symbol Names Using Microsoft® Excel

Reduce costs of program development with Microsoft® Excel.

I/O tables, including symbols, address and I/O comments can be copied and pasted directly from CX-Programmer to MS Excel® or from MS Excel® to CX-Programmer.

Microsoft® Excel Spreadsheet

Numeric table in CX-Programmer

IC Symbol	Address	I/O comment
X Seq Vals NC1_n0	2020.3C	Sequence_NO_Val0(Memory_Opr)(Device)
X Act NC1_n0	2020.01	Activation(Memory_Opr)(Device)(Unit No.0)
X Alone Act NC1_n0	2020.02	Stand-alone_Activation(Memory_Opr)(Device)(Unit No.0)
X Abs_Cmnd NC1_n0	2020.05	Abs_Command(Direct_Opr)(Device)(Unit No.0)
X Inr_Cmnd NC1_n0	2020.04	Inr_Command(Direct_Opr)(Device)(Unit No.0)
X Inr_Fc_Feed NC1_n0	2020.04	InrEmat_Feed_Length_Feed(Direct_Opr)(Device)(Unit No.0)
X Orig_Srch NC1_n0	2020.04	Origin_Search(Event)(Unit No.0)
X Orig_Ret NC1_n0	2020.03	Origin_Return(Event)(Unit No.0)
X Preset NC1_n0	2020.04	Present_Position_Preset(Device)(Unit No.0)
X Jog NC1_n0	2020.04	Jog_Feed(Event)(Unit No.0)
X J_Dr NC1_n0	2020.1F	Jog_Direction_refine(Event)(Unit No.0)
X Teaching NC1_n0	2020.11	Teaching(Event)(Unit No.0)
X Pulse_Inh_Rel NC1_n0	2020.12	Pulse_Out_Inhibit_Release(Event)(Unit No.0)
X Err_Reset NC1_n0	2020.13	ErrCounter_ResetOutput_Corrig adjust_OUT
X Override NC1_n0	2020.14	Override_Val(Event)(Unit No.0)
X Decel_Stop NC1_n0	2020.15	Decel_Stop(Event)(Unit No.0)
X Compul_Act NC1_n0	2020.16	Compulsory_Activation(Event)(Unit No.0)
X Data_Write NC1_n0	2020.17	Data_Write(Event)(Unit No.0)

1. Copy I/O allocation tables and other data with MS-Excel.

2. Paste the data into a numeric table.

3. Select from the numeric table when entering instruction operands. Use the presrch function to make program development even easier.

Entering Operands for Instructions

CX-Programmer

■ Use Automatic Address Allocations for Increased Flexibility

CX-Programmer can automatically allocate I/O addresses. Assign a memory block size to any of the available data types, and CX-Programmer will auto allocate and increment addresses with the block.

Local or Global Variable Table

Name	Type	Address/Value	Data Location	Usage	Comment
module1	BOOL	W0.00 [Auto]		Work execution module1	
module2	BOOL	W0.01 [Auto]		Work execution module2	
LS1	BOOL	0.00		Work limit SW1	
LS2	BOOL	0.01		Work limit SW2	

1. Enter symbols into the variable table, omitting specific addresses.

Automatic Address Allocation Dialog Box

2. Specify allocation word ranges in the automatic address allocation dialog box.

3. Addresses will be automatically allocated to local or global variables memory areas.

CX-Programmer

■ Network Configurations Made Easy

Configuring a network of PLCs couldn't be easier, with the CX-NET network configuration tool, setup PLC network routing tables, I/O tables, and data link tables.

Quickly connect to any PLC on the network.

From any single location along the network using Omron's single-port multiple-access (SPMA) technology, you can:

- See devices present on the network.
- Run network diagnostics.
- Create and transfer network routing and data link tables.

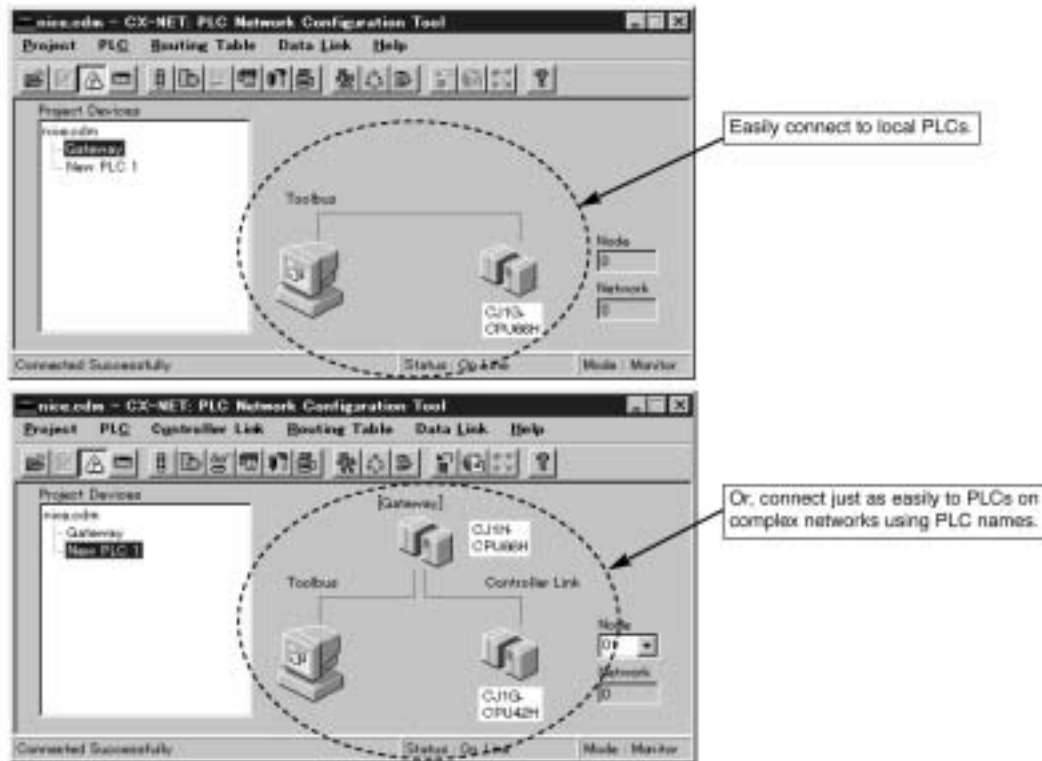

CX-Simulator

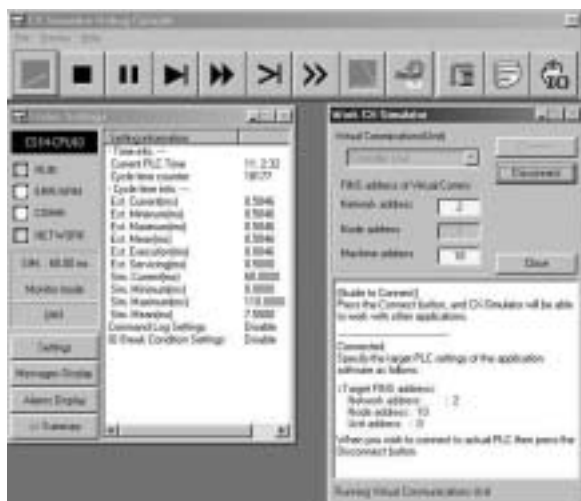

■ Key Features

- Transfer logic programs using CX-Programmer just as with actual CJ1 or CS1 PLC connected.
- Simulate input conditions.
- Single step logic programs.
- Set break points.
- Filter for I/O conditions.
- Test/debug serial devices with “Live” connections through serial port.
- Send/receive FINS commands.
- Test/debug HMI/SCADA applications.
- Easy connections to CX-Programmer from toolbar menu.

CX-Simulator is a powerful software tool that functions as a virtual CJ1/CS1 PLC. It's the ultimate tool for CX-Programmer developers to efficiently design, test and debug program logic as well as serial and network connections. The program runs on a Windows® -based PC.

Use CX-Simulator prior to project startup when physical connections to the hardware are not available. Developed programs can be run and edited, I/O can be simulated to conform to field devices, network communications can be tested and program scan rates can be calculated. Existing programs can also be evaluated, providing the most efficient means of improving system performance.

Leverage all the debugging features of CX-Programmer and more. Download ladder programs to CX-Simulator's virtual CJ1/CS1 just as you would an actual Omron CJ1 or CS1 CPU and work “online” with CX-Programmer editing and testing.

Create I/O expressions, or a debugging ladder logic program to simulate virtual external inputs. It's even possible to input an actual PLC “Data Trace” or collect “Time Chart Monitor” data from CX-Programmer for input simulation.

■ Ordering Information

Product Description	Version Type	Language Support	Operating System	Model Number
CX-Simulator, single license	Full version	English, Japanese	WIN XPro, 2KPro, NT4.0 (sp 3+), 95, 98, Me	WS02-SIMC1-E
CX-Simulator, 3-pack license	Full version	English, Japanese	WIN XPro, 2KPro, NT4.0 (sp 3+), 95, 98, Me	WS02-SIMC1-EL03
CX-Simulator, 10-pack license	Full version	English, Japanese	WIN XPro, 2KPro, NT4.0 (sp 3+), 95, 98, Me	WS02-SIMC1-EL10

CX-Protocol

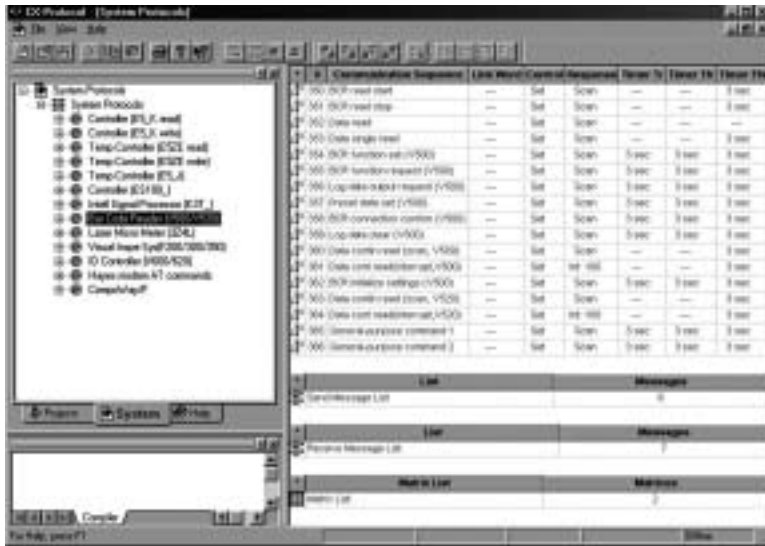

■ Key Features

- Communicate with serial RS-232 and RS-422/485 devices.
- Supports half-duplex or full-duplex modes.
- Assignable error check code to send/receive commands.
- Conversions for ASCII and Hex numerical data.
- Pre-built functions for inserting into command strings.
- Programmable flow control.
- Includes protocols for Omron temperature controllers, panel meters, bar code readers, vision sensors, and Hayes compatible modems.
- “Live” monitoring of transmissions for testing/debugging command strings.
- Combine with C200Hα, CJ1, or CS1 series Serial Communications Modules.

When it is time to connect a serial device to a C200Hα, CJ1, or CS1 series PLC and exchange data, use CX-Protocol to make the job simple and easy.

It doesn't matter if it's an Omron or non-Omron product; communicate to any serial device through a C200Hα, CJ1, or CS1 series Serial Communications modules with both RS-232 and RS-422/485 ports.

With CX-Protocol, develop the communication protocol for any serial device and transfer it to a C200Hα, CJ1, or CS1 series serial module's processor just like a logic program.

All the serial command processing is executed from within the module, not from the CPU. To call a created protocol for use in a program, select the CX-Programmer Protocol Macro (PMCR) command to exchange data between the serial device and logic program running on the CJ1 PLC CPU.

■ Ordering Information

Product Description	Version Type	Language Support	Operating System	Model Number
CX-Protocol, single license	Full version	English, Japanese	WIN XPPro, 2KPro, NT4.0 (sp 3+), 95, 98, Me	WS02-PSTC1-E

CX-Motion



■ Key Features

- Full 32-bit Windows® application.
- Windows style interface.
- Powerful editing features maximize design and programming efficiency.
- Advanced monitoring, display, and debugging functions reduce engineering time and implementation costs.
- Extensive, context sensitive help system.
- Import program files, parameters, and position data created in previous versions of Omron's MC Support Software.
- Create projects containing one or more MC unit.
- Data is displayed in a tree format in the project workspace.
- User defined mnemonics or G codes for programming.
- An automatic loading function enables easy downloading of MC programs and position data stored on a personal computer, providing support for systems requiring more programs or position data than the MC module can store on its own.
- A Servo Trace function simplifies system tuning and setup. This function enables the user to trace speed reference, present speed, and error counter with a specified starting condition and specified sampling period of 2-100ms up to 500 samples.

CX-Motion is an easy-to-use software tool that allows users to quickly set up and program Omron's Motion Control (MC) modules in an intuitive Windows-based environment. Customers can reuse existing programs written for the new CS1W motion modules, C200H-MC221, and CV500-MC221/421 modules. This software tool has features that simplify MC module setup, including a servo trace function that allows users to trace speed reference, present speed, and error counter, a programming choice of G codes or mnemonics, and an automatic downloading function that allows users to download MC programs and position data to a PC. CX-Motion also enables users to create projects containing multiple MC units and then displays the data in a 'tree' format in the project workspace.

Note: CX-Motion software must be used to program CS1W motion modules.

■ Ordering Information

Product Description	Version Type	Language Support	Operating System	Model Number
CX-Motion, single license	Full version	English, Castilian Spanish, French, German, Italian	Windows® 95, 98, 2000, NT	WS02-MCTC1-E

CX-Position



Key Features

- CX-Position makes entering parameters easy and reduces engineering time. (See screen capture.)
- CX-Position allows you to create backup files on your PC and to document program parameters.
- Windows® Explorer style Interface.
- Easily and quickly configure parameters such as soft limits, homing methods, display units, and max. speed.
- Setup motion sequences, acceleration/deceleration profiles, speeds, dwell times, zone flags, etc.
- Monitor single or multiple modules for position, I/O status (e.g. limits, origin sensors position completed) error log sequences in progress and more.

Simplify configuring and monitoring of motion parameters for the single and multi-axis CJ1W-NC Position Control modules using CX-Position software. These modules provide flexible motion control of servo and stepper drives using pulse-train command outputs.

CX-Position has the added ability of handling multiple PLCs with multiple modules all in one project. Furthermore, it will now be possible to easily move NC data and perform copy and paste functions in the project.

Ordering Information

Product Description	Version Type	Language Support	Operating System	Model Number
CS1W-NC support software, single license	Full version	English	Windows® 95, 98, 2000, NTv4.0	WS02-NCTC1-E

CX-Supervisor



■ HMI Solutions for Data Acquisition and Control

Omron offers *three software solutions* (CX-Supervisor, CX-ServerLite, CX-ServerOPC) for gathering and displaying data on a Windows®-based PC. **CX-Supervisor** provides a *complete solution* with tools to develop an HMI project from start to finish for Omron programmable controllers, across *all* Omron network protocols.

- Need the “hook” for third-party HMI/SCADA communications to Omron controllers and networks? Use **CX-ServerLite**. It provides the ActiveX control required to exchange data.
- If the legacy third-party HMI system uses an OPC client/server approach, use **CX-ServerOPC**.

Note: CX-ServerLITE and CX-ServerOPC offer the additional benefits of creating HMI projects in Microsoft Excel and Visual Basic depending on the developer’s skill level.

Each of the Three Software Packages:

- Allows convenient drag-and-drop development of HMI screens using a library of images (switches, lamps, gauges) and other ActiveX characters/images.
- Provides complete access to all Omron programmable controller platforms, network protocols and controller memory areas. Project developers no longer have the tedious tasks of writing and testing code for communications and building graphical objects for control and display.
- Developers can reuse the I/O point database already created with CX-Programmer to exchange data quickly and easily.

■ CX-Supervisor Tops the List of HMI Solutions

Are you looking for a Windows®-based HMI software package packed with features and large I/O tag counts to interface to Omron PLCs? CX-Supervisor is it!

CX-Supervisor is flexible enough for supervision and control of a single PLC or an entire manufacturing environment of PLCs. Windows Explorer-style development environment makes building the most sophisticated graphical interfaces simple. Intuitive Wizards and an extensive on-line help make it even easier.

More than just a HMI product, CX-Supervisor includes powerful alarm functionalities, logging, trending, database connectivity, and advanced scripting options all contained in one package.

CX-Supervisor supports Microsoft COM/DCOM, DDE, OPC, OLE, activeX, and ADO/OLEDB standard technologies.

■ Key Features

- Objects/animation, simple drawing object or more complex OLE objects.
- Includes many ActiveX controls.
- Libraries of over 3000 graphic symbols.
- Create recipes for transferring process data to and from Omron PLCs.
- Alarming provides notification for unwanted conditions of I/O points.
- Security levels limit access to specific project actions for single users or groups.
- Re-uses I/O point database from other CX-Automation Suite products.
- “ActiveX” container.
- Choice of three languages: CX-Supervisor base script, VBA script, and JAVA script OPC client.
- DDE Client/Server data trending.
- Data logging.
- Data base connections using ADO/OLEDB.

■ Ordering Information

Product Description	Version Type	Language Support	Operating System	Model Number
CX-Supervisor demonstration, no license	Demo	English, French, German, Italian, Spanish	WIN XPPro, 2KPro, NT4.0 (sp 3+), 95, 98	CX-SUPERVISOR-DEMO-V□.□
CX-Supervisor project development studio, single license	Full version	English, French, German, Italian, Spanish	WIN XPPro, 2KPro, NT4.0 (sp 3+), 95, 98	CX-SUPERVISOR-V□.□*
CX-Supervisor runtime software and single license	Full version	English, French, German, Italian, Spanish	WIN XPPro, 2KPro, NT4.0 (sp 3+), 95, 98	CX-SUPERVISOR-RUN-HL-V□.□
CX-Supervisor, single license only	Full version	English, French, German, Italian, Spanish	WIN XPPro, 2KPro, NT4.0 (sp 3+), 95, 98	CX-SUPERVISOR-HL-V□.□*
CX-Supervisor, single license	Upgrade version	English, French, German, Italian, Spanish	WIN XPPro, 2KPro, NT4.0 (sp 3+), 95, 98	CX-SUPERVISOR-UPGR-V□.□**

*Note: Part number CX-SUPERVISOR-HL-V□.□ needed to active run/test projects developed with part number CX-SUPERVISOR-V□.□

**Note: Available in Canada only.

CX-ServerLITE



CX-ServerLITE contains an ActiveX communication control to interface to CX-Server Runtime providing Windows PC-based applications communication to Omron PLCs and temperature controllers. The ActiveX control can be used within a Microsoft-compliant ActiveX container making it especially easy when deployed within Excel or Visual Basic. In addition ActiveX control also includes a set of graphical Omron ActiveX controls, making it not only easy for exchange of data but creation of custom HMI applications.

■ Key Features

- “ActiveX” communication control for Omron PLCs.
- Create HMI applications using Microsoft Excel and Visual Basic.
- Set of Omron ActiveX graphical controls.
- Works with third-party ActiveX controls.
- Script command set.
- Drag-and-drop toolbar.
- Proven and reliable connections to Omron hardware.
- Reuse I/O point database with other CX-Automation Suite products.

■ Omron PLC Communications

Easily connect Windows PC-based applications to Omron hardware. No custom code to write or debug.

Graphical “ActiveX” Controls

Turns Microsoft Excel into a PC-based HMI and saves time in Visual Basic.

I/O Point Database

Reuse I/O point data from CX-Programmer and other CX-Automation Suite products. Allows direct importing of CX-Programmer CDM file to CX-ServerLITE project saving valuable engineering development time.

Omron Network Service Boards (NSB)

FINS Gateway drivers for all Omron Network Service boards included.

Third-Party “ActiveX” Controls

Use your favorite Microsoft compliant ActiveX control. Connect it to CX-ServerLITE using the Omron ActiveX Linker control. Configure it through the Linker control properties menu; there is no code to write.

Script Command Set

For more advanced users, ActiveX communication control can be accessed through Visual Basic script. Powerful commands are available for such things as sending and receiving FINS messages to/from Omron PLCs as well as reading and writing arrays of data. The command set is available in the included manual and online help. Sample applications of Microsoft Excel and Visual Basic are included to help demonstrate the use of these commands.

■ Ordering Information

Product Description	Version Type	Language Support	Operating System	Model Number
CX-ServerLITE Omron ActiveX control, no license	Demo Version	English, French, German, Italian, Spanish	WIN XPPro, 2KPro, NT4.0 (sp 3+), 95, 98	CX-SERVER-LITE-DEMO-V□.□
CX-ServerLITE Omron ActiveX control, single license, supports Omron serial network protocol connections only	Serial Network Version	English, French, German, Italian, Spanish	WIN XPPro, 2KPro, NT4.0 (sp 3+), 95, 98	CX-SERVER-LITE-SERIAL-V□.□
CX-ServerLITE Omron ActiveX control, single license, supports all Omron network protocols	All Network Version	English, French, German, Italian, Spanish	WIN XPPro, 2KPro, NT4.0 (sp 3+), 95, 98	CX-SERVER-LITE-V□.□

CX-ServerOPC



Why OPC?

HMI and SCADA applications communicate with control networks using drivers designed to different vendor specifications. In the past, this meant that each HMI vendor had to create a multitude of drivers and driver interfaces to their products. This created a product development and support nightmare.

The OPC standard was created to solve this problem. Now, an HMI vendor can create a single OPC client interface for their software. This OPC client can interface to any OPC server on the market. Vendors, such as Omron, have created reliable OPC servers that support their networks. So, when an OPC client is connected to the OPC server, the HMI package freely exchanges data.

Key Features

- Omron OPC Server providing third-party OPC Client HMI/SCADA applications connectivity to Omron PLCs, Omron's other PLCs and Networks.
- OPC Client ActiveX controls turns Microsoft Excel & Visual Basic into OPC Client applications.
- Bridge between multiple vendor OPC Servers using OPC Client ActiveX control.
- Set of Omron ActiveX graphical controls.
- Works with third-party ActiveX controls.
- Script command set.
- Drag-and-drop toolbar.
- Proven and reliable connections to Omron hardware.
- Reuse I/O point database with other CX-Automation Suite products.

Ordering Information

Product Description	Version Type	Language Support	Operating System	Model Number
CX-ServerOPC Omron OPC Server no license	Demo Version	English, French, German, Italian, Spanish	WIN XPPro, 2KPro, NT4.0 (sp 3+), 98	CX-SERVER-OPC-DEMO-V□.□
CX-ServerOPC Omron OPC Server, single license, supports Omron serial network protocol connections only	Serial Network Version	English, French, German, Italian, Spanish	WIN XPPro, 2KPro, NT4.0 (sp 3+), 98	CX-SERVER-OPC-SERIAL-V□.□
CX-ServerOPC Omron OPC Server, single license, supports all Omron network protocols	All Network Version	English, French, German, Italian, Spanish	WIN XPPro, 2KPro, NT4.0 (sp 3+), 98	CX-SERVER-OPC-V□.□

Three CX-ServerOPC Components

Omron OPC Server

CX-ServerOPC provides an Omron OPC Server for customers needing to exchange data between Omron PLC and Temperature controllers and OPC Client applications, typically HMI/SCADA packages.

IMPORTANT:

The Omron OPC Server supports version 2.0 of the OPC specification only, OPC Client applications must support OPC v2.0 Data Access (DA) of the OPC specification to be used with the Omron OPC Server.

CX-ServerOPC supports all Omron communication protocols and all the available memory locations for a specific PLC. Developed projects can easily be converted from one communication protocol to another without having to rewrite the application

OPC Client ActiveX Control

CX-ServerOPC also includes an OPC Client ActiveX control for Microsoft® Excel and Visual Basic (VB).

Using the ActiveX control customers can create their own OPC Client HMI/SCADA from Excel or VB without having to write any of the underlying code for the OPC data exchange between the OPC Server and OPC Client.

The OPC Client ActiveX control can be used with the Omron OPC Server as well as any compliant third-party OPC Server.

An Excel or Visual Basic OPC Client application can be developed to exchange data between multiple vendor OPC Servers at the same time acting as a bridge between different vendor OPC Servers.

This means that through using the Omron OPC Client ActiveX control, a single Excel or Visual Basic application can be developed to interface to Omron PLCs and someone else's at the same time. When you have applications with multiple PLC vendors in a manufacturing environment needing a simple way to exchange and share data, this is the answer!

Graphical ActiveX Controls

Graphical ActiveX controls provide pushbuttons, data displays, and a data-logging viewer. They can be used in Excel or Visual Basic, an Excel spread sheet can be made into a "front end" to PLCs, saving development time in Visual Basic providing pre-built controls.

Hand-Held Programmiers

Compact, Hand-Held Programmiers for All Omron Programmable Controllers



- Monitor PLC operations on the factory floor and perform troubleshooting diagnostics.
- Write, modify and debug programs.
- Backlit LCD on C200H-PRO27-E allows easy viewing under all lighting conditions.

■ Hand-Held Programmiers

Description	Model Number
Hand-held programming console with cable attached, 2 m length; connects directly to mini-peripheral port	CQM1H-PRO01-E
Hand-held programming console with back light (cable not included)	C200H-PRO27-E

■ Connecting Cables For Hand-Held Programmiers

Description	Length	Model Number
PLC-to-programmer cable for C200H-PRO27-E (for all PLCs except CPM1A and CPM2A)	2 m	CS1W-CN224
	6 m	CS1W-CN624
CPM1A/CPM2A PLC-to-programmer cable for C200H-PRO27-E	2 m	C200H-CN222

■ Accessories

Description	Model Number
Mounting bracket for C200H-PRO27-E	C200H-ATT01
CJ1 and CS1 key sheet for C200H-PRO27-E	CS1W-KS001-E

■ CQM1H-PRO01-E Programming Console

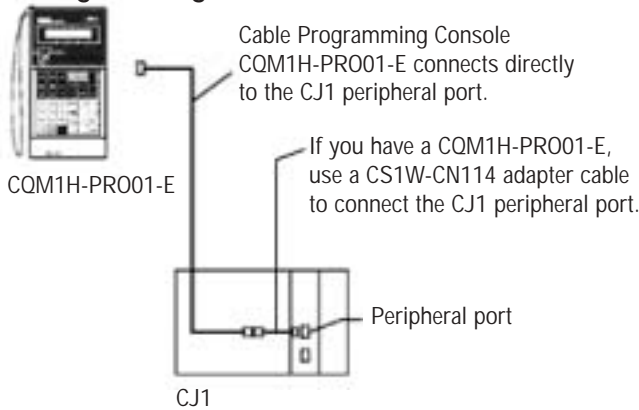

■ C200H-PRO27-E Programming Console

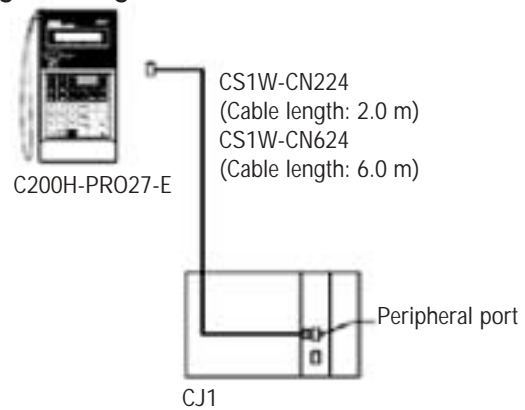

■ Dimensions

Unit: mm (inch)

CQM1H-PRO01-E

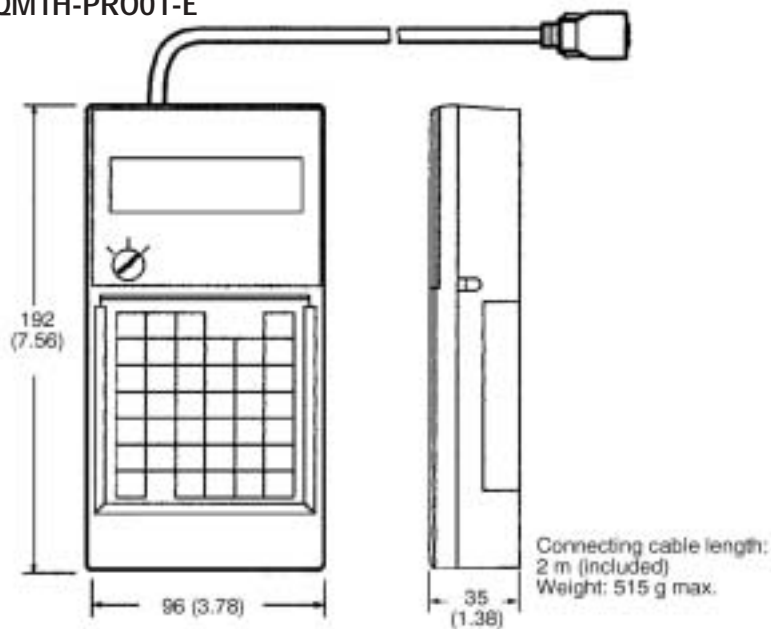

C200H-PRO27-E

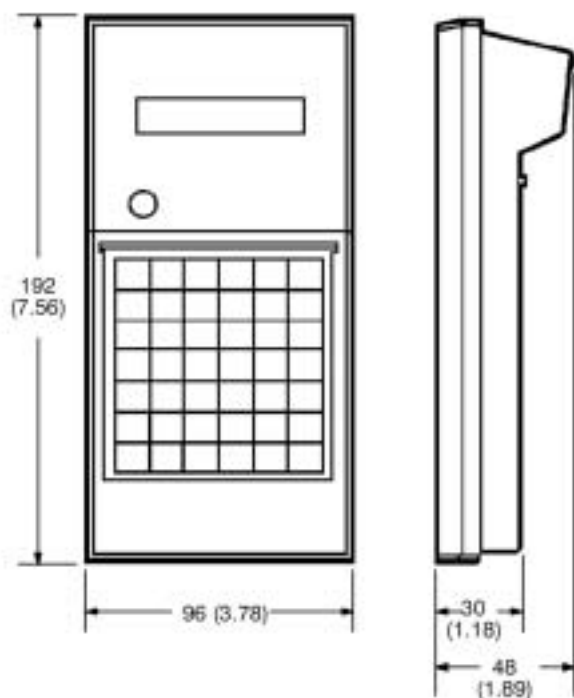

C200H-CN224/CN624 Connecting Cable

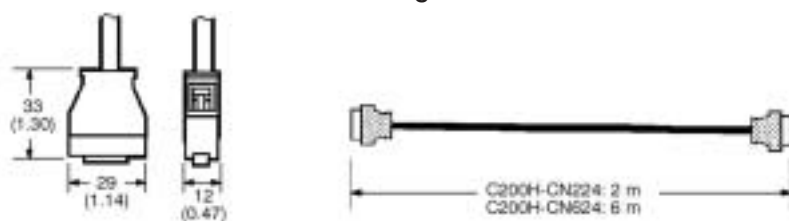

■ **Software Programming Cables**

Description	Length	Model Number
Serial port DB9-pin on computer to PLC peripheral port	2 m	CS1W-CN226
	6 m	CS1W-CN626
Serial port DB9-pin on computer to Omron DB9-pin serial port	2 m	C200HS-CN229-EU
Peripheral port adapter (converts between RS-232C cable and peripheral port)	0.1 m	CS1W-CN118
Cable-mounted communication adapter converts peripheral port to DB9-pin serial port	3.3 m	CQM1-CIF02
Converts CQM1-CIF02 DB9-pin serial connector for CQM1H peripheral port	0.05 m	CS1W-CN114
USB connector to serial converter. Requires CS1W-CN226/626	0.5 m	CS1W-CIF31

■ **Cable Compatibility from Computer RS-232 Serial Port to PLC Port**

CPU Type	Cable Model Number	PLC Port Type
CPM1A	CQM1-CIF02	Peripheral
CPM2A	CQM1-CIF02	Peripheral
CPM2C	CS1W-CN226/626	Mini Peripheral
CPM2C-S	CS1W-CN226/626	Mini Peripheral
CPM2B	CS1W-CN226/626	Mini Peripheral
CQM1H	CS1W-CN226/626	Mini Peripheral
CJ1	CS1W-CN226/626	Mini Peripheral
CS1	CS1W-CN226/626	Mini Peripheral
CS1D	CS1W-CN226/626	Mini Peripheral

■ **Omron Personnel Computer USB to Serial Port Converter**

Description	Model Number
PC USB to Serial converter	CS1W-CIF31

Note: CS1W-CIF31 does not provide direct connections to PLC peripheral port. Use with any of the above "PC RS-232 - to -PLC port" to provide connections for programming CPU types.

Connecting to the Peripheral Port

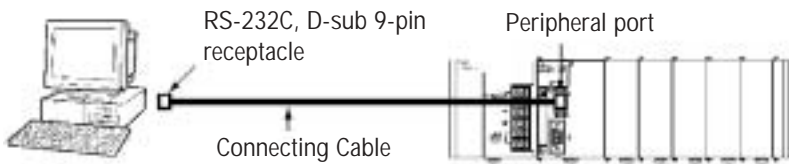

Peripheral Port Connecting Cables

Cable	Length	Computer connector
CS1W-CN226	2 m	D-sub, 9-pin male
CS1W-CN626	6 m	

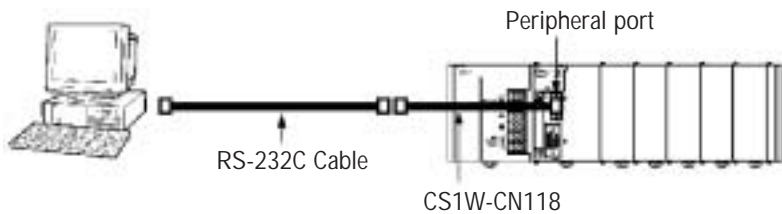

Connecting to the RS-232C Port

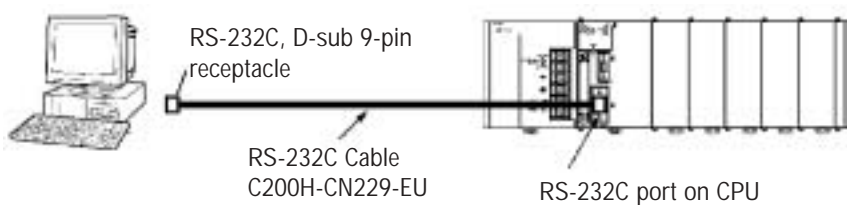

RS-232C Port Connecting Cables

Cable	Length	Computer connector
C200H-CN229-EU	2 m	D-sub, 9-pin male

Certain Terms and Conditions of Sale

1. **Offer; Acceptance.** These terms and conditions (these "Terms") are deemed part of all catalogs, manuals or other documents, whether electronic or in writing, relating to the sale of goods or services (collectively, the "Goods") by Omron Electronics LLC and its subsidiary companies ("Seller"). Seller hereby objects to any terms or conditions proposed in Buyer's purchase order or other documents which are inconsistent with, or in addition to, these Terms. Please contact your Omron representative to confirm any additional terms for sales from your Omron company.
2. **Prices.** All prices stated are current, subject to change without notice by Seller. Buyer agrees to pay the price in effect at time of shipment.
3. **Discounts.** Cash discounts, if any, will apply only on the net amount of invoices sent to Buyer after deducting transportation charges, taxes and duties, and will be allowed only if (i) the invoice is paid according to Seller's payment terms and (ii) Buyer has no past due amounts owing to Seller.
4. **Orders.** Seller will accept no order less than \$200 net billing.
5. **Governmental Approvals.** Buyer shall be responsible for, and shall bear all costs involved in, obtaining any government approvals required for the importation or sale of the Goods.
6. **Taxes.** All taxes, duties and other governmental charges (other than general real property and income taxes), including any interest or penalties thereon, imposed directly or indirectly on Seller or required to be collected directly or indirectly by Seller for the manufacture, production, sale, delivery, importation, consumption or use of the Goods sold hereunder (including customs duties and sales, excise, use, turnover and license taxes) shall be charged to and remitted by Buyer to Seller.
7. **Financial.** If the financial position of Buyer at any time becomes unsatisfactory to Seller, Seller reserves the right to stop shipments or require satisfactory security or payment in advance. If Buyer fails to make payment or otherwise comply with these Terms or any related agreement, Seller may (without liability and in addition to other remedies) cancel any unshipped portion of Goods sold hereunder and stop any Goods in transit until Buyer pays all amounts, including amounts payable hereunder, whether or not then due, which are owing to it by Buyer. Buyer shall in any event remain liable for all unpaid accounts.
8. **Cancellation; Etc.** Orders are not subject to rescheduling or cancellation unless Buyer indemnifies Seller fully against all costs or expenses arising in connection therewith.
9. **Force Majeure.** Seller shall not be liable for any delay or failure in delivery resulting from causes beyond its control, including earthquakes, fires, floods, strikes or other labor disputes, shortage of labor or materials, accidents to machinery, acts of sabotage, riots, delay in or lack of transportation or the requirements of any government authority.
10. **Shipping; Delivery.** Unless otherwise expressly agreed in writing by Seller:
 - a. Shipments shall be by a carrier selected by Seller;
 - b. Such carrier shall act as the agent of Buyer and delivery to such carrier shall constitute delivery to Buyer;
 - c. All sales and shipments of Goods shall be FOB shipping point (unless otherwise stated in writing by Seller), at which point title to and all risk of loss of the Goods shall pass from Seller to Buyer, provided that Seller shall retain a security interest in the Goods until the full purchase price is paid by Buyer;
 - d. Delivery and shipping dates are estimates only.
 - e. Seller will package Goods as it deems proper for protection against normal handling and extra charges apply to special conditions.
11. **Claims.** Any claim by Buyer against Seller for shortage or damage to the Goods occurring before delivery to the carrier must be presented in writing to Seller within 30 days of receipt of shipment and include the original transportation bill signed by the carrier noting that the carrier received the Goods from Seller in the condition claimed.
12. **Warranties.** (a) **Exclusive Warranty.** Seller's exclusive warranty is that the Goods will be free from defects in materials and workmanship for a period of twelve months from the date of sale by Seller (or such other period expressed in writing by Seller). Seller disclaims all other warranties, express or implied. (b) **Limitations.** SELLER MAKES NO WARRANTY OR REPRESENTATION, EXPRESS OR IMPLIED, ABOUT NON-INFRINGEMENT, MERCHANTABILITY OR FITNESS FOR A PARTICULAR PURPOSE OF THE GOODS. BUYER ACKNOWLEDGES THAT IT ALONE HAS DETERMINED THAT THE GOODS WILL SUITABLY MEET THE REQUIREMENTS OF THEIR INTENDED USE. Seller further disclaims all warranties and responsibility of any type for claims or expenses based on infringement by the Goods or otherwise of any intellectual property right. (c) **Buyer Remedy.** Seller's sole obligation hereunder shall be to replace (in the form originally shipped with Buyer responsible for labor charges for removal or replacement thereof) the non-complying Good or, at Seller's election, to repay or credit Buyer an amount equal to the purchase price of the Good; provided that in no event shall Seller be responsible for warranty, repair, indemnity or any other claims or expenses regarding the Goods unless Seller's analysis confirms that the Goods were properly handled, stored, installed and maintained and not subject to contamination, abuse, misuse or inappropriate modification. Return of any goods by Buyer must be approved in writing by Seller before shipment. Seller shall not be liable for the suitability or unsuitability or the results from the use of Goods in combination with any electrical or electronic components, circuits, system assemblies or any other materials or substances or environments. Any advice, recommendations or information given orally or in writing, are not to be construed as an amendment or addition to the above warranty.
13. **Damage Limits; Etc.** SELLER SHALL NOT BE LIABLE FOR SPECIAL, INDIRECT OR CONSEQUENTIAL DAMAGES, LOSS OF PROFITS OR PRODUCTION OR COMMERCIAL LOSS IN ANY WAY CONNECTED WITH THE GOODS, WHETHER SUCH CLAIM IS BASED IN CONTRACT, WARRANTY, NEGLIGENCE OR STRICT LIABILITY. Further, in no event shall liability of Seller exceed the individual price of the Good on which liability is asserted.
14. **Indemnities.** Buyer shall indemnify and hold harmless Seller, its affiliates and its employees from and against all liabilities, losses, claims, costs and expenses (including attorney's fees and expenses) related to any claim, investigation, litigation or proceeding (whether or not Seller is a party) which arises or is alleged to arise from Buyer's acts or omissions under these Terms or in any way with respect to the Goods. Without limiting the foregoing, Buyer (at its own expense) shall indemnify and hold harmless Seller and defend or settle any action brought against Seller to the extent that it is based on a claim that any Good made to Buyer specifications infringed intellectual property rights of another party.
15. **Property; Confidentiality.** The intellectual property embodied in the Goods is the exclusive property of Seller and its affiliates and Buyer shall not attempt to duplicate it in any way without the written permission of Seller. Notwithstanding any charges to Buyer for engineering or tooling, all engineering and tooling shall remain the exclusive property of Seller. All information and materials supplied by Seller to Buyer relating to the Goods are confidential and proprietary, and Buyer shall limit distribution thereof to its trusted employees and strictly prevent disclosure to any third party.
16. **Miscellaneous.** (a) **Waiver.** No failure or delay by Seller in exercising any right and no course of dealing between Buyer and Seller shall operate as a waiver of rights by Seller. (b) **Assignment.** Buyer may not assign its rights hereunder without Seller's written consent. (c) **Amendment.** These Terms constitute the entire agreement between Buyer and Seller relating to the Goods, and no provision may be changed or waived unless in writing signed by the parties. (d) **Severability.** If any provision hereof is rendered ineffective or invalid, such provision shall not invalidate any other provision. (e) **Setoff.** Buyer shall have no right to set off any amounts against the amount owing in respect of this invoice. (f) As used herein, "including" means "including without limitation".

Certain Precautions on Specifications and Use

1. **Suitability of Use.** Seller shall not be responsible for conformity with any standards, codes or regulations which apply to the combination of the Good in the Buyer's application or use of the Good. At Buyer's request, Seller will provide applicable third party certification documents identifying ratings and limitations of use which apply to the Good. This information by itself is not sufficient for a complete determination of the suitability of the Good in combination with the end product, machine, system, or other application or use. The following are some examples of applications for which particular attention must be given. This is not intended to be an exhaustive list of all possible uses of this Good, nor is it intended to imply that the uses listed may be suitable for this Good:
 - (i) Outdoor use, uses involving potential chemical contamination or electrical interference, or conditions or uses not described in this document.
 - (ii) Energy control systems, combustion systems, railroad systems, aviation systems, medical equipment, amusement machines, vehicles, safety equipment, and installations subject to separate industry or government regulations.
 - (iii) Systems, machines and equipment that could present a risk to life or property. Please know and observe all prohibitions of use applicable to this Good.
2. **Programmable Products.** Seller shall not be responsible for the user's programming of a programmable Good, or any consequence thereof.
3. **Performance Data.** Performance data given in this catalog is provided as a guide for the user in determining suitability and does not constitute a warranty. It may represent the result of Seller's test conditions, and the user must correlate it to actual application requirements. Actual performance is subject to the Seller's Warranty and Limitations of Liability.
4. **Change in Specifications.** Product specifications and accessories may be changed at any time based on improvements and other reasons. It is our practice to change part numbers when published ratings or features are changed, or when significant construction changes are made. However, some specifications of the Good may be changed without any notice. When in doubt, special part numbers may be assigned to fix or establish key specifications for your application. Please consult with your Seller's representative at any time to confirm actual specifications of purchased Good.
5. **Errors and Omissions.** The information in this catalog has been carefully checked and is believed to be accurate; however, no responsibility is assumed for clerical, typographical or proofreading errors, or omissions.

NEVER USE THE PRODUCT FOR AN APPLICATION INVOLVING SERIOUS RISK TO LIFE OR PROPERTY WITHOUT ENSURING THAT THE SYSTEM AS A WHOLE HAS BEEN DESIGNED TO ADDRESS THE RISKS, AND THAT THE SELLER'S PRODUCT IS PROPERLY RATED AND INSTALLED FOR THE INTENDED USE WITHIN THE OVERALL EQUIPMENT OR SYSTEM.

Complete “Terms and Conditions of Sale” for product purchase and use are on Omron’s website at www.omron.com/oei – under the “About Us” tab, in the Legal Matters section.

ALL DIMENSIONS SHOWN ARE IN MILLIMETERS.

To convert millimeters into inches, multiply by 0.03937. To convert grams into ounces, multiply by 0.03527.

OMRON[®]**OMRON ELECTRONICS LLC**

One Commerce Drive
Schaumburg, IL 60173

847-843-7900

For US technical support or other inquiries:

800-556-6766**OMRON CANADA, INC.**

885 Milner Avenue
Toronto, Ontario M1B 5V8

416-286-6465**OMRON ON-LINE**

Global - <http://www.omron.com>

USA - <http://www.omron.com/oei>

Canada - <http://www.omron.ca>