



LIGHT ECO PLUS

Lighting Controller

Proven Technology - Real Savings

specialist designers and producers
of energy-saving lighting devices
and motor control

Light Eco Plus Save up to 40% on your lighting costs

- Save up to 40% on your lighting costs and see your electricity bill slashed
- See what you save at a glance or download your savings history
- Reduce your impact on the environment by cutting greenhouse gas emissions
- Fast return on investment - typical ROI within 12 to 18 months
- Quick and easy Installation
- Over 60,000 installations worldwide
- Suitable for any space that uses fluorescent lighting such as offices, warehouses, shops and factories
- Using world leading Australian innovation and technology

The proven energy and cost saver for fluorescent and high bay lighting

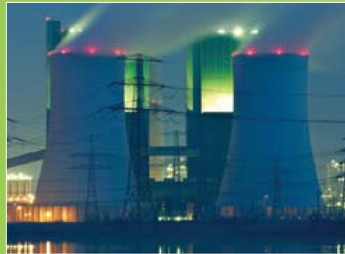

Case Study

20 fully loaded Light Eco Plus devices installed in a factory with 1400 tubes operating for 20 hours a day would achieve:

- £14,000 saving on the annual electricity bill
- CO² reduction of 52 tonnes
- 100% return on investment in 12 months*

*saving based on average kilowatt hour price of 12p

"The Energy Saving portfolio that Fairford Energy offers has been a great success for Energy Saving Solutions. The energy-saving technologies have been employed in the private and public sector and to date have been extremely successful. Following initial trials a major fast food restaurant chain has agreed to install lighting controls at 1052 of their sites, initial results show that they are achieving an average reduction in lighting cost of in excess of 36%" - Ian Mills - Energy Saving Solutions

Features

- Models from 10A to 20A standard. Larger units are available.
- LCD Display showing percentage saving, voltage, current and power.
- Bypass switch to allow manual bypass of unit during maintenance.
- External control option for use with PIR sensors, daylight sensor and BMS.
- USB option allows you to download the savings history and view real time data.
- HID version available.

How Does Light Eco Plus Work?

Light Eco Plus is a cost effective and compact controller that delivers significant energy savings by controlling the amount of electricity that reaches a fluorescent lighting circuit.

After fluorescent lights have been switched on and warmed up, they can operate effectively on a reduced power supply.

Light Eco Plus works by allowing lights to turn on at the standard utility voltage and then reducing the electricity supply to economy mode.

With Light Eco Plus the savings are easy to see. The LCD panel on the device clearly shows the savings being made and the information is stored so that the savings history is available for download*.

**requires optional hardware and software.*

Easy Installation

Light Eco Plus is easily installed into existing fluorescent lighting circuits and can be installed by an electrician in less than 30 minutes. Interruption and lighting downtime is a matter of minutes.

Light Eco Plus is designed for retro fitting into existing installations, eliminating the need for expensive modifications. Once installed, there are no ongoing costs - only ongoing savings.

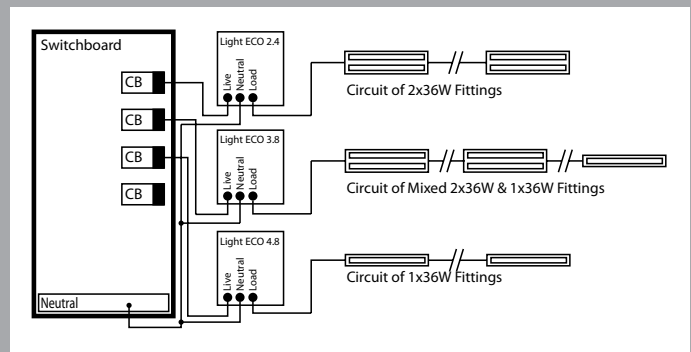

Manufactured by: ILUM-A-LITE PTY LTD
Authorised Distributor: Fairford Energy

Other Energy Saving Products from Fairford Energy



HFE

Single Phase Motor Energy Saving Soft Starter

- Automatic Energy Saving
- Easy Installation - 2 In 2 Out
- No Maintenance Needed
- **Save Up To 40%**



XFE

Three Phase Motor Energy Saving Soft Starter

- Automatic Energy Saving
- LCD Display
- Automatic Set Up
- **Save Up To 40%**



LED

Replacement for Halogen Bulbs

- **Save up to 80%**
- Lamp Life of 30,000+ Hours
- 100° Beam Angle
- Light Output of 60Lm/W



SAVE IT EASY

Energy Saving Retrofit Solution

- Converts conventional ballasts to high frequency ballast, capable of fitting T5 and T8 tubes.
- **Savings Up to 56%**
- Fast, Easy Installation



for more information contact us
now on tel: +44(0) 1548 857494
or email: info@fairfordenergy.co.uk
www.fairfordenergy.co.uk



Fairford Energy -
A division of Fairford Electronics Ltd,
Coombe Works, Derby Road, Kingsbridge, Devon.
TQ7 1JL United Kingdom

tel: + 44 (0) 1548 857494
fax + 44 (0) 1548 853118

info@fairfordenergy.co.uk
www.fairfordenergy.co.uk

Light Eco Plus – Installation and User Manual

Installation

Mounting

Light Eco Plus can be wall mounted vertically or horizontally, or ceiling mounted.

The unit must have adequate ventilation and should ***never be mounted upside down***

When mounted in rows the following ***minimum separation*** between units must be observed:

Horizontal space between units	50mm
Vertical space between units	100mm

Electrical Connection

Electrical connections are made at the terminal block under the small cover at the base of the unit.

Only qualified Electrical Contractors may connect Light Eco Plus to the lighting circuits. Before connecting, lighting circuits must be measured for current (amp) load with all lights turned on. Maximum load permitted for each unit is:

Light Eco Plus 2.4 - 8 amps

Light Eco Plus 3.8 - 14 amps

Light Eco plus 4.8 - 18 amps

Typical connection for well loaded lighting circuits

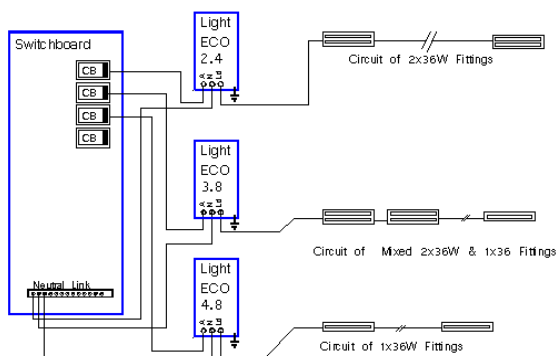

Connection for lightly loaded circuits where some circuits can be combined

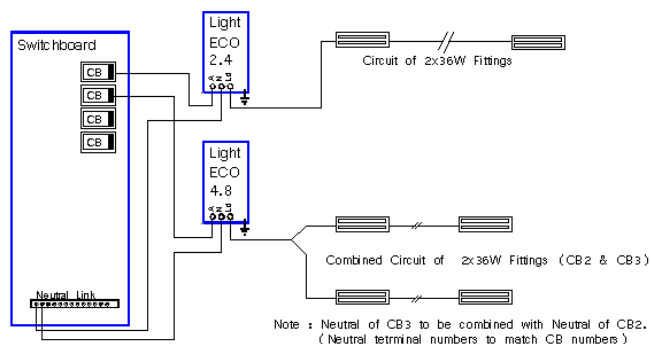

Operation

Light Eco Plus is fully automatic and requires no user operation to perform its intended task of saving more than 25% of the lighting power on the circuit.

Principle of operation

Discharge lighting such as fluorescent lighting requires high power to start up but once operating at full temperature and output, can operate at reduced power with minimal impact on performance while saving more than 25% of power.

Light Eco Plus is a microprocessor controlled device which allows the lights to power up correctly and, when conditions are appropriate, switches to **economy mode** and automatically reduces the power to the lights.

While in **economy mode** Light Eco Plus constantly monitors the power and returns to **full power mode** if required. Typically this will be due to another bank of lights being turned on or a critical drop in supply power. It may also be because of an operator intervention to perform lamp maintenance.

User Display

Light Eco Plus has a display on the front panel which gives immediate indication of its operation and energy saving.

Condition	Display	Description
Lights off	Lights Off	Lights are off and unit is in standby
Lights switched on New lighting load After bypass or programming	Warm Up 240 V, 11 A, 2.1kW	Lights have just been turned on and are warming up. Unit in full power mode. Volts, Amps and Power (in Kilowatts) is displayed
Economy	Eco Saves 28% 240 V, 7.9 A, 1.5kW,	Unit is in economy mode. Volts, Amps, Power (in Kilowatts) and percentage power saving is displayed
Supply voltage too low	Low Mains Voltage 216 V, 10 A, 1.9kW	Unit has detected critical drop in Mains Voltage. Unit in full power mode. Volts, Amps and Power (in Kilowatts) is displayed
Overload	Overload (<i>flashing</i>) 245 V, 21 A, 4.1kW	Unit in full power safe mode. Circuit breaker on lights is likely to trip
Bypass switch activated	Bypass Mode 43 minutes	Unit has been commanded into Bypass Mode for lamp maintenance. Unit in full power mode. Unit will return to Economy mode in 43 minutes

Bypass function

Light Eco Plus is fitted with a switch which, when operated, commands the unit to **full power mode** for a preset time period. The main purpose of this is to allow maintenance and lamp changing to take place with lights operating at full power. It is also used in HID dimming applications to restore full light output.

Factory preset time is 60 minutes and a countdown timer is displayed to indicate time remaining. At the end of the period Light Eco Plus checks the lighting system and if operating conditions are correct, resumes **economy mode**.

Should the operator want to resume **economy mode** before the countdown timer runs out, pressing the bypass switch will cause Light Eco Plus to commence the cycle necessary to return to **economy mode**.

The 60 minute default timer can be changed up or down by a qualified technician using the programming options below.

Programming display

Light Eco Plus can be fitted with an optional USB access port to which a laptop or similar portable device may be attached with the appropriate software installed. When connected the programmer is able to change a number of parameters of the Light Eco Plus or download stored information about energy use and saving on the unit.

Connecting to the USB port will automatically cause the unit to switch to **full power mode**

Condition	Display	Description
External programming	Program Change	The unit has been accessed to change any one of the variable options
Data download	Data Transfer	Transferring stored data of V, A and W

Programmable options:

Option	Variable	Application
Warm up time	1-15 minutes	To adapt to ambient conditions or different light types such as HID
Current sensing	1-4 amps	To adjust the point at which the unit will switch to full power when a new bank of lights is switched on
Voltage Sensing	Voltage drop	Adjusts from factory preset levels at which the unit enters full power mode if supply voltage drops
Voltage Sensing	Voltage restore	Adjusts from factory preset levels at which the unit enters economy mode when supply voltage recovers
Bypass timer	Time 5 minutes to 12 hours	Time until economy mode is automatically resumed after the bypass button is pressed
Minimum current	Amps	The minimum number of amps deemed to be "Lights Off"

Note: Changing factory preset levels should only be done by a qualified technician who has been trained in the operation of Light Eco Plus. Changes made by an unqualified person may result in poor performance of the lighting or reduced energy saving from Light Eco Plus