

Type: **P3-100/V/SVB**  
 Article No.: **088558**  
 Sales text **CIRCUIT INTERRUPTER P3-100(UK)**



Ordering information			
			BME-CAT Fotos
Produktgruppen-Bezeichnung			T rotary switches, P switch-disconnectors, technical data
			Load current switches
			Main switches, maintenance switches
Design			Rear mounting
Basic type for ... insert mounting form			P3-100/...
Mounting form			V/SVB
No. of poles		M	3
Description			As Emergency-Stop device

General			
Standards			IEC/EN 60 947, VDE 0660, IEC/EN 60 204, CSA,UL Switch-disconnectors to IEC/EN 60 947-3 NEMA3R, NEMA12, NEMA13
Lifespan, mechanical	Operations	$\times 10^6$	0,1
Maximum operating frequency	Operations/h		50

Climatic proofing			Damp heat, constant, to IEC 60068–2–78; Damp heat, cyclical, to IEC 60068–2–30
Ambient temperature			
Open		°C	–25...50
Enclosed		°C	–25...40
Mounting position			As required
Mechanical shock resistance to IEC 60068–2–27	Half-sinusoidal shock 20 ms	g	> 15
<b>Contacts</b>			
Rated operational voltage	$U_e$	V AC	690
Rated impulse withstand voltage	$U_{imp}$	V AC	6000
Overvoltage category/pollution degree			III/3
Rated uninterrupted current			
open	$I_u$	A	100
Enclosed	$I_u$	A	100
Load rating with intermittent operation, class 12			
AB 25 % DF		$\times I_e$	2
AB 40 % DF		$\times I_e$	1,6
AB 60 % DF		$\times I_e$	1,3
Short-circuit rating			
Fuse		A gG/gL	100
Rated short-time withstand current (1 s current)	$I_{cw}$	$A_{rms}$	2000
Switching angles		°	90
Current heat loss per contact at $I_e$		W	7,5
<b>Terminal capacities</b>			
Solid or stranded		mm <sup>2</sup>	1 × (2.5 – 35) 2 × (2.5 – 10)
Flexible with ferrule to DIN 46228		mm <sup>2</sup>	1 × (1.5 – 25) 2 × (1.5 – 6)
Terminal screw			M5
Tightening torque		Nm	3
<b>Switching capacity</b>			
AC			
Rated making capacity $\cos \phi = 0.35$		A	950
Rated breaking capacity, motor			

load switch $\cos \phi = 0.35$			
230 V		A	760
400 V		A	740
500 V		A	880
690 V		A	520
Rated operational current 440 V load-break switch AC-21A	$I_e$	A	100
AC-3 motor load switch motor rating			
230 V	$P$	kW	22
400 V	$P$	kW	37
500 V	$P$	kW	45
690 V	$P$	kW	37
AC-23A Motor load switches (main switches maintenance switches)			
230 V	$P$	kW	30
400 V	$P$	kW	50
500 V	$P$	kW	65
690 V	$P$	kW	45
DC			
DC-1, Load-break switches L/R = 1 ms			
Rated operational current	$I_e$	A	100
Voltage per contact pair in series		V	60
DC-23A, motor load switch L/R = 15 ms			
24 V			
Rated operational current	$I_e$	A	50
Contacts		Quantity	1
48 V			
Rated operational current	$I_e$	A	50
Contacts		Quantity	2
60 V			
Rated operational current	$I_e$	A	50
Contacts		Quantity	3
120 V			
Rated operational current	$I_e$	A	25
Contacts		Quantity	3
<b>Notes</b>			

**Notes**

Main switch characteristics to IEC/EN 60204; positive opening of contacts, operator element positively located on shaft  
The rated uninterrupted current  $I_U$  is stated at max. connected cross-section.  
For terminal capacity solid, stranded and flexible:  
Max. 2 cross-section sizes difference admissible when using 2 conductors.

**Dimensions**

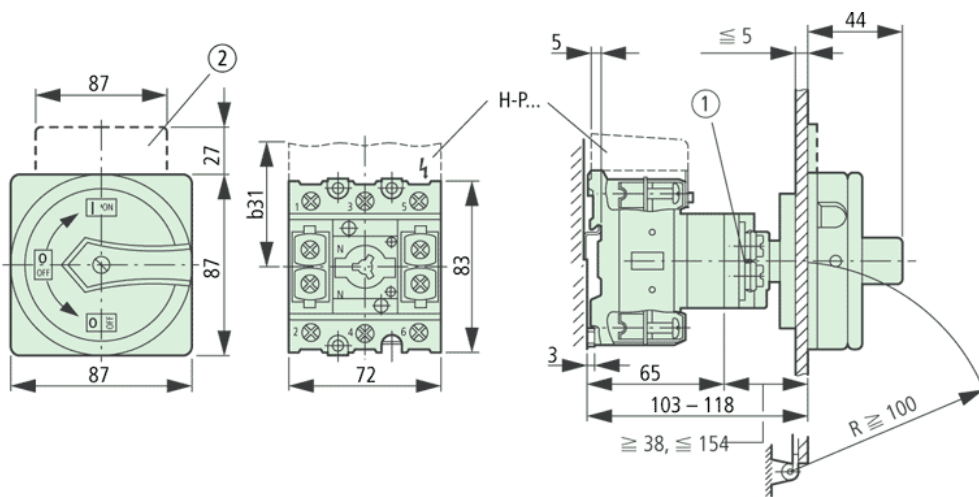

Shaft can be extended using ZVV-... + ZAV-..., max.  $F 4 \times 25 = 100$  mm  
Not included

**Dimensions**

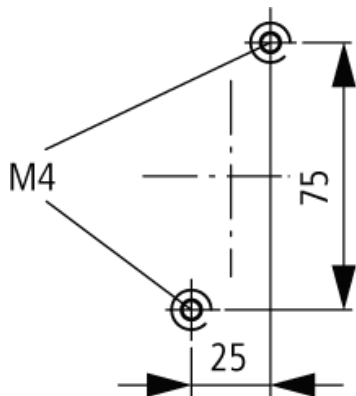

Diameter of drilled hole Bottom

**Dimensions**

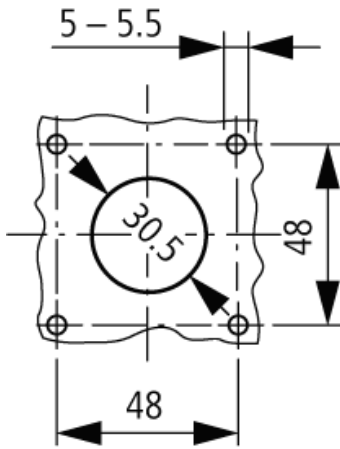

Diameter of drilled hole Door

### Dimensions

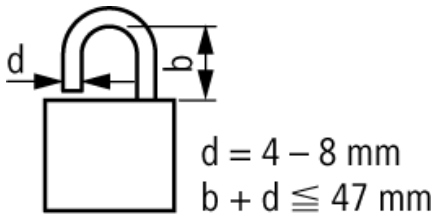

3 Padlocks

### Characteristic curve

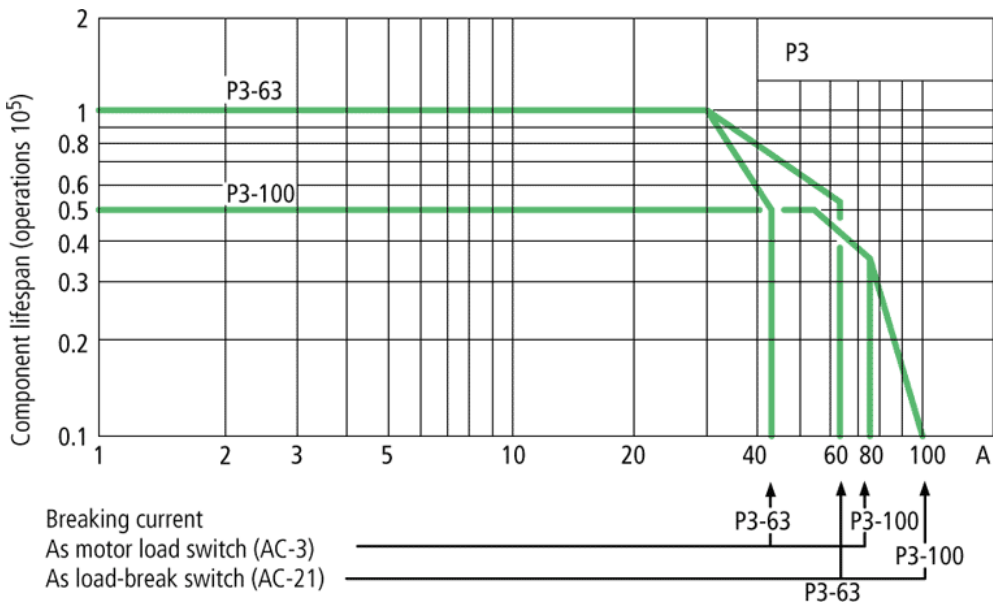

For utilisation category AC-4 (extreme load: 100 % inching, reversing or plugging)  
 The blocked rotor current of the motor should not exceed the rated current of the switch for AC-21A to ensure a reasonable device lifespan.

Moeller GmbH, Hein-Moeller-Str. 7-11, D-53115 Bonn

E-Mail: [catalog@moeller.net](mailto:catalog@moeller.net), Internet: [www.moeller.net](http://www.moeller.net), <http://catalog.moeller.net>  
HPL-C2007G V2.1 © 2007 by Moeller GmbH