

SDP1000 / SDP2000

Low Range Differential Pressure Sensor for Air and Non-Aggressive Gases



- For cost sensitive HVAC and medical OEM applications
- Unsurpassed performance thanks to CMOSens® technology
- Offset and hysteresis free
- Excellent accuracy and reproducibility even below 10 Pa
- Fully calibrated and temperature compensated
- Linear or square root extracted output characteristics available
- Not sensitive to the mounting orientation
- Direct PCB mounting with simple snap-on system



actual size

Data Sheet – v4.0

SDP1000 / SDP2000 Product Summary

The SDP1000 / SDP2000 differential pressure sensors for air cover the following measurement ranges: -5 to 125 Pa (0.5 inch H₂O), -20 to 500 Pa (2 inch H₂O), and -100 to 3500 Pa (14 inch H₂O).

Mounted in a rugged, chemically inert PPS housing the SDP1000 / SDP2000 differential pressure sensors feature a unique dynamic range, zero offset and unsurpassed long term stability. This makes it an ideal fit for demanding yet cost sensitive OEM applications in HVAC and medical equipment.

The devices are supplied with 5.0 V and provide a 0.25...4.0 V output. Although the output of the SDP1000 / SDP2000 differential pressure sensor is analog, the internal linearization and temperature compensation is performed digitally. This results in a superior accuracy, outstanding resolution (up to 0.05 Pa), and lowest temperature dependence. The SDP1000 is available with a linear or square root extracted output characteristics at the same price. Since fully exchangeable just a few external electronic components

around the SDP1000 / SDP2000 make a high quality differential sensor transmitter with e.g. an 0...10 V output or other interfaces (see Figure 8).

Its leading performance is based on Sensirion's proprietary CMOSens® sensor technology which combines the sensor element with amplification and A/D conversion on one single silicon chip. The differential pressure is measured by a thermal sensor element. In contrast to other thermal differential pressure sensors only a very small amount of air is required (see Figure 6). This leads to a reliable operation even under harsh conditions. In comparison to membrane based sensors the SDP1000 / SDP2000 differential pressure sensors show an extended measurement range, better offset stability and improved reproducibility even at lowest pressure ranges (see Figure 1 and 2). In addition the SDP1000 / SDP2000 is robust against pressure bursts and shows no sensitivity to the mounting orientation.

SDP1000 / SDP2000 is fully RoHS compliant.

Applications

- Medical
- HVAC
- Automotive
- Process Automation

Block Diagram

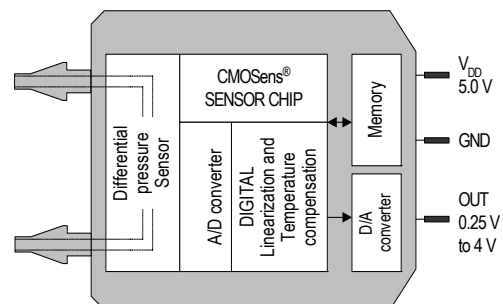

1 Specifications

Table 1: Sensor specifications (at 23°C and $p_{\text{absolute}} = 966 \text{ mbar}$, $V_{\text{DD}} = 5.0 \text{ V}$ unless otherwise noted).

Parameter	SDP1000-L025			SDP1000-L05			SDP1000-L			SDP1000-R			SDP2000-L			Unit
	Min	Typ	Max	Min	Typ	Max	Min	Typ	Max	Min	Typ	Max	Min	Typ	Max	
Measurement range	-62		62	-5		125	-20		500	-20		500	-100		3500	Pa
	-0.25		0.25	-0.02		0.5	-0.08		2	-0.08		2	-0.4		14	Inch water
Power supply (see Tab 4)	4.75	5.00	5.25	4.75	5.00	5.25	4.75	5.00	5.25	4.75	5.00	5.25	4.75	5.00	5.25	V
Full scale output (100 k Ω load)	Typ. 4.00V at +62Pa Typ. 0.20V at -62Pa			4.00			4.00			4.00			4.00			V
Zero Pressure Output		2.10			0.250			0.250			0.250			0.250		V
Accuracy (also see Figure 1)		0.5	0.6		0.2	0.3		0.1	0.2		0.2	0.3		0.1	0.2	% FS ⁽¹⁾⁽²⁾
		1.5	2		1.5	2		1	1.5		1	1.5		1	1.5	% m.v. ⁽¹⁾
Repeatability		0.3	0.5		0.3	0.5		0.3	0.5		0.3	0.5		0.3	0.5	% m.v. ⁽¹⁾
Offset stability		0	± 0.1		0	± 0.1		0	± 0.1		0	± 0.3		0	± 0.3	Pa / year
Additional error over temperature (T \neq 23°C)		0.003	0.006		0.003	0.006		0	0		0	0		0	0	% FS/ $^{\circ}\text{C}$ ⁽²⁾
		0.03	0.05		0.03	0.05		0.03	0.05		0.03	0.05		0.03	0.05	% m.v./ $^{\circ}\text{C}$
Resolution < 30% FS ⁽¹⁾							0.05	0.1	0.2	0.05	0.1	0.2	0.2	0.5	1	Pa
Resolution 30..70% FS ⁽¹⁾	0.05	0.1	0.2	0.05	0.1	0.2	0.2	0.5	1.5	0.2	0.5	1.5	1	2.5	8	Pa
Resolution > 70% FS ⁽¹⁾							1.5	2.2	3	1.5	2.2	3	8	11	14	Pa

⁽¹⁾ FS = full scale or span, m.v. = measured value, i.e. reading, whichever value is bigger

⁽²⁾ FS = full scale or span, i.e. for the SDP1000 it is 500 Pa (2 "H₂O), for the SDP2000 it is 3500 Pa (14 "H₂O)

⁽³⁾ See 2.2 Voltage Output formula for conversion

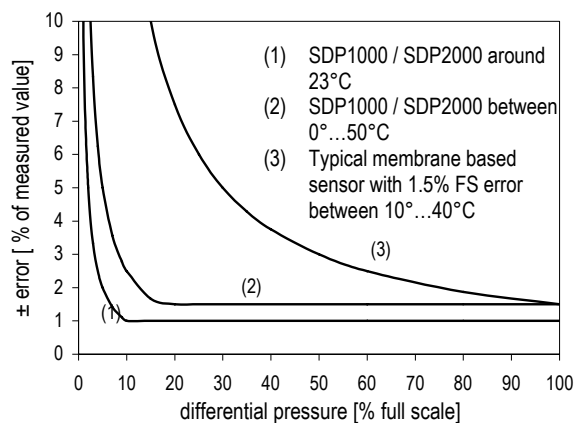

Figure 1: Accuracy (includes errors caused by offset, linearity, hysteresis and repeatability) of the SDP1000 -L (1), (2) compared with typical membrane sensors (3).

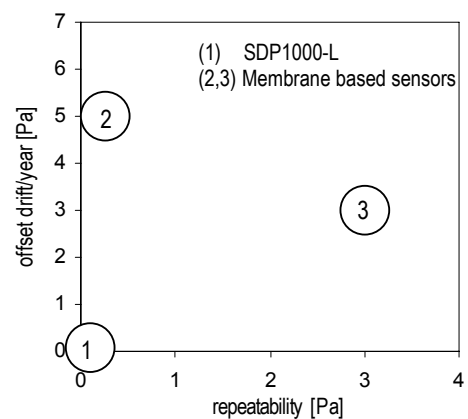

Figure 2: Max. repeatability and offset drift/year of the SDP1000-L (1) compared with two typical membrane based sensors (2,3).

Table 2: Additional sensor specifications.

Media	Air, N ₂ – for other gases contact Sensirion AG.
Operating Conditions: - Temperature - Humidity	-10 °C ... +60 °C / 14°F ... 140 °F non-condensing
Ambient storage conditions ¹	-40 °C ... +80 °C / -40°F ... 176 °F
Position sensitivity	below resolution
Response time	40 ms (for faster response time contact Sensirion)
Admissible overpressure (short term)	1 bar (14.5 PSI)
Burst Pressure Capability	2 bar (29 PSI)
Weight	14 g
Protection Class	IP 20
Wetted materials	Glass (silicon nitride, silicon oxide), Silicon, PPS (Polyphenylene Sulfide), PEEK (Polyetheretherketone), FR4, Silicone as static sealing, Epoxy, Gold
Gas flow through sensor	see Figure 6.
Lead free	The SDP1000 family is fully RoHS compliant

⁽¹⁾ For maximum 2 weeks

1.1 Temperature Compensation

The SDP1000 / SDP2000 differential pressure sensors feature a sophisticated built-in temperature compensation circuit. The temperature is measured on the CMOSens chip by means of a PTAT bandgap reference temperature sensor. Its data is fed into a compensation circuit which is also integrated on the CMOSens[®] sensor chip. No external temperature compensation is therefore required.

1.2 Altitude Correction

The SDP1000 / SDP2000 differential pressure sensors achieve their unsurpassed performance by using a dynamic measurement principle, i.e. an applied differential pressure forces a small air flow through the sensor. This results in a dependence of the indicated differential pressure on the ambient air density. While the temperature effect is compensated (see Paragraph 1.1) the altitude above sea level has an influence on the SDP1000 / SDP2000 output. If desired, this effect can be compensated by a correction factor according to the following equation:

$$Dp_{\text{eff}} = Dp_{\text{sensor}} \cdot P_{\text{cal}} / P_{\text{amb}}$$

where Dp_{eff} is the effective differential pressure, Dp_{sensor} the differential pressure indicated by the SDP1000 / SDP2000, P_{cal} the absolute pressure during calibration (966 mbar) and P_{amb} the actual ambient absolute pressure.

This leads to the following correction factors:

Table 3: Altitude correction factors.

Altitude [meter]	Ambient Pressure (P_{amb}) [mbar]	Correction Factor $P_{\text{cal}} / P_{\text{amb}}$
0	1013	0.95
250	984	0.98
425	966	1.00
500	958	1.01
750	925	1.04
1500	842	1.15
2250	766	1.26
3000	697	1.38

Example:

The SDP1000 is used at 750 m above sea level. The output of the SDP1000 shows 0.5 V, which corresponds to $Dp_{\text{sensor}} = 33.3$ Pa. Taking into account the correction factor $P_{\text{cal}} / P_{\text{amb}} = 1.04$ the effective differential pressure Dp_{eff} is $33.3 \text{ Pa} \cdot 1.04 = 34.6$ Pa.

Note:

In many HVAC applications such as filter monitoring, fan/ventilator control or air flow measurement the described effect is actually welcome since at the end the mass flow and not volume flow is the effective value to control.

2 Electrical Specifications

2.1 Power Supply

The SDP1000 / SDP2000 differential pressure sensors require a stable voltage supply of 5 V. Influence of the supply voltage variation on the offset and the sensitivity are given in Table 5.

2.2 Voltage Output

The SDP1000 / SDP2000 features a voltage output from 0.25 V to 4.0 V (Figure 2, 3). An output voltage below 0.25 V indicates a negative differential pressure. This range is not calibrated however. Exempt from this statement is the SDP1000-L025, which features a fully bidirectional calibration with 0.2 to 4.0 V output.

The resistive load at the output pin should be larger than 20 kOhm. The capacitive load at the output pin must not be larger than 200 pF. If the design shows a larger capacity at the output pin an additional resistor is required in series at the output (e.g. 620 Ohm).

Linear output

Formula: $P = \text{lfactor} * (\text{voltage}^{(1)} - 0.250)/3.750$

lfactor =	SDP1000-L05	SDP1000-L	SDP2000-L
Pascal	125	500	3500
Inch water	0.5	2	14

⁽¹⁾ voltage: measured output voltage in Volt.

Square Root output

Formula: $P = \text{rfactor} * (\text{voltage}^{(1)} - 0.250)^2$

rfactor =	SDP1000-R
Pascal	35.55556
Inch water	0.14222

⁽¹⁾ voltage: measured output voltage in Volt.

For bi-directional SDP1000-L025

Formular: $P = \text{lfactor} * (\text{voltage} - 2.10)/1.90$

lfactor = 62 Pa or 0.25 Inch water

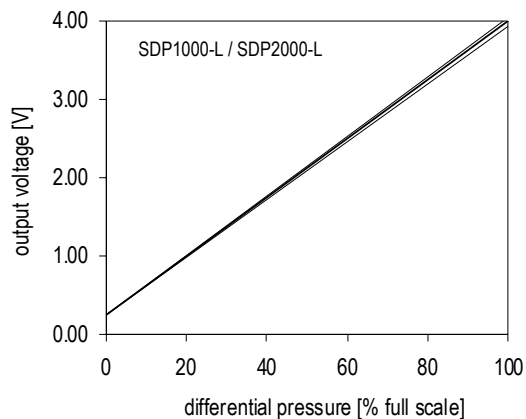

Figure 2: Linear output at 5 Vdc supply of the SDP1000-L and the SDP2000-L. The fine lines indicate the maximum tolerances including a temperature variation from 0 to 50°C.

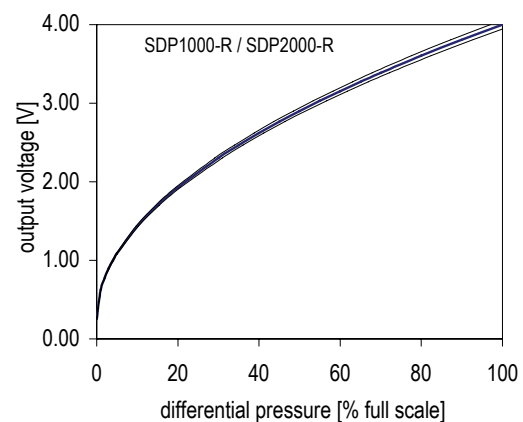

Figure 3: Square root extracted output of the SDP1000-R and the SDP2000-R at 5 Vdc supply. The fine lines indicate the maximum tolerances including a temperature variation from 0 to 50°C.

Table 4: SDP1000 / SDP2000 electrical characteristics.

Parameter	Conditions	Min.	Typ.	Max.	Units
Power Supply Voltage V_{DD}		4.75	5.0	5.25	VDC
Operating Current	5 V, no load, zero flow		4.3	5.2	mA
Output capacitive load C_{load}			20	200	pF
Recommended load R_{load}		20	100	∞	k Ω

Table 5: Typical power supply dependence of the offset and the sensitivity.

Parameter	Device	4.75 V	5.0 V	5.25 V	Units
Offset	SDP1000-L05	- 0.4		+ 0.4	Pa
	SDP1000-L	- 1.6		+ 1.6	
	SDP2000-L	- 10.3		+ 10.3	
Sensitivity	SDP1000-L05	28	30	32	mV/Pa
	SDP1000-L	7.1	7.5	7.9	
	SDP2000-L	1.01	1.07	1.13	

3 Physical Dimensions and Mounting Information

3.1 Housing

The SDP1000 / SDP2000 differential pressure sensor is mounted in chemically inert PPS housing. The rugged package has been designed to withstand continuous overpressures of at least 1 bar (14.5 PSI). Burst pressure is > 2 bar (29 PSI)

The physical dimensions and mounting information is given in Figure 4 and 5.

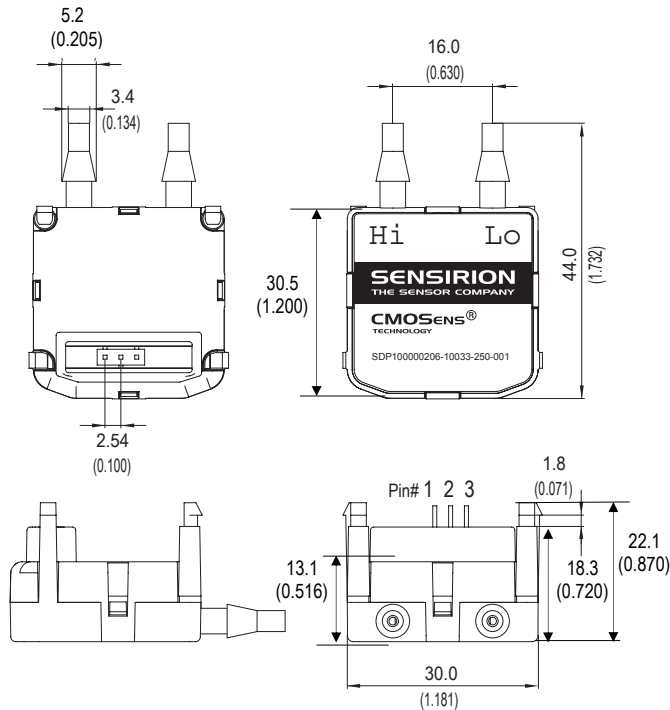

Pin#	Function
1	VDD (5 Vdc)
2	Ground
3	OUT (0.25...4 Vdc)

Figure 4: Pin out and physical dimensions in mm (inch). The drawing is not to scale.

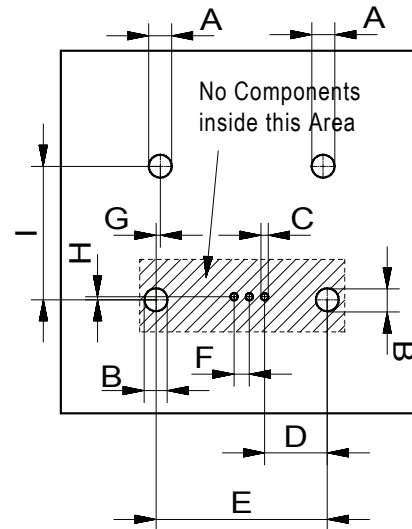

Dim.	[mm]	[inch]	[mil]
A	3.00	0.118	118
B	3.30	0.130	130
C	1.20	0.047	47
D	10.20	0.402	402
E	28.20	1.110	1110
F	2.54	0.100	100
G	0.60	0.024	24
H	0.50	0.020	20
I	22.70	0.894	894

Figure 5: SDP1000 / SDP2000 PCB footprint. The drawing is not to scale.

3.2 Soldering Instructions

The SDP1000 / SDP2000 differential pressure sensor can be wave soldered. Direct reflow soldering is not recommended since it may affect the accuracy. If reflow soldering is required Sensirion recommends to use an SMD connector (e.g. type Samtec SSM-

103-L-SV) and to mount the SDP1000 / SDP2000 after soldering.

3.3 Connecting Hose

Sensirion recommends a hose with an inner diameter of 1/8 to 3/20 inch (3.18 to 3.8mm). Due to the dynamic measurement principle, a small air flow is required (Figure 6) which

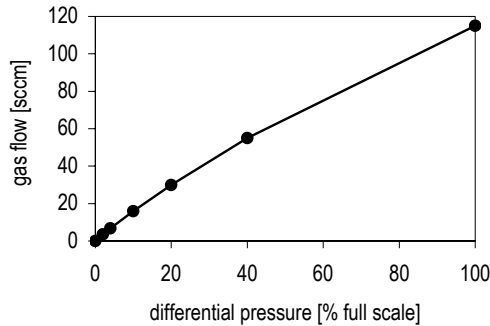

Figure 6: Typical air flow through the SDP1000 / SDP2000. Please note: 1 sccm = 1 cm³/min at 0°C and 1013 mbar pressure (1 sccm = 0.001 norm liter).

leads to a dependence on the length of the hose (Figure 7). Tubes up to 1 m show less than 1 % error of the measured value (Figure 7).

Length of the connecting hose	Deviation of Measured Value
0.5 m (20 inch)	- 0.4 %
1.0 m (40 inch)	- 0.8 %
2.0 m (80 inch)	- 1.6 %
4.0 m (160 inch)	- 3.2 %

Figure 7: Influence of the length of the connecting hose on the accuracy (using 3/16 inch inner diameter). Example: a 50 Pa difference pressure is shown as 49.8 Pa when using 0.5 m tube with 3/16 inch diameter.

4 Application Example: A High End Differential Pressure Sensor

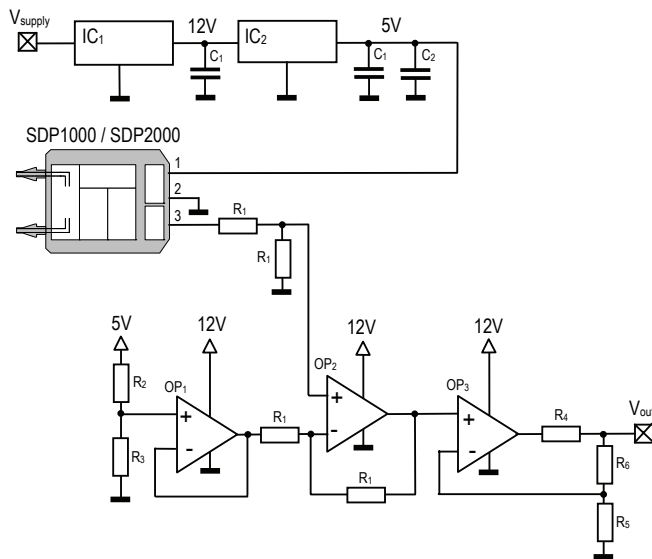

$$V_{out} = (V_{SDP} - 5V \cdot (R_3/(R_2+R_3))) \cdot (R_5+R_6)/R_5$$

Example:

Output V_{out} : 0... 10 Vdc
Range: 0...500 Pa, linear characteristics
Power supply V_{supply} : 14.5... 27 Vdc

Component	Value
IC ₁	LM78L12
IC ₂	LP2980
SDP	SDP1000
OP ₁ , OP ₂ , OP ₃	LMC6044
C ₁	200 nF
C ₂	2.2 uF
R ₁	10 kΩ (5%, 10 ppm)
R ₂	18 kΩ (5%, 10 ppm)
R ₃	1 kΩ (5%, 10 ppm)
R ₄	100 Ω
R ₅	6 kΩ (3x18 kΩ 5%, 10 ppm in parallel)
R ₆	10 kΩ (5%, 10 ppm)

Figure 8: Schematic of a high-end differential pressure transmitter using the SDP1000 / SDP2000. With only a few external components and no additional calibration the transmitter features an accurate and temperature compensated 0...10 Vdc output signal. (Component values not valid for SDP1000-L025.)

5 Ordering Information

When ordering SDP1000 / SDP2000 differential pressure sensors please refer to the following part names and article numbers. For the latest product information and local distributor check out Sensirion's website on <http://www.sensirion.com>

Table 6: Overview ordering information

Part Name	Output	Range (Full Scale)				Article Number
		\pm 62 Pa	\pm 62 mbar	\pm 0.25 "H ₂ O	\pm 0.009 PSI	
SDP1000-L025	Voltage 0.2 – 4.0 V, linear	\pm 62 Pa	\pm 62 mbar	\pm 0.25 "H ₂ O	\pm 0.009 PSI	1-100313-02
SDP1000-L05	Voltage 0.25 - 4.0 V, linear	125 Pa	1.25 mbar	0.5 "H ₂ O	0.018 PSI	1-100235-02
SDP1000-L	Voltage 0.25 - 4.0 V, linear	500 Pa	5 mbar	2 "H ₂ O	0.07 PSI	1-100110-02
SDP2000-L	Voltage 0.25 - 4.0 V, linear	3500 Pa	35 mbar	14 "H ₂ O	0.50 PSI	1-100113-02
SDP1000-R	Voltage 0.25 - 4.0 V, square root	500 Pa	5 mbar	2 "H ₂ O	0.07 PSI	1-100111-02
SDPx000-OEM	For high quantity OEM versions (e.g. with digital output), please contact Sensirion.					-

6 Revision history

Table 7: Revision history

Date	Version	Page(s)	Changes
November 2002	Preliminary v0.9	all	First preliminary release
January 2003	First release	all	Specifications, typos, various small modifications
December 2004	V2.6	all	Introduction type L05
Juni 2005	V2.7	all	Change of address, adjusted specifications for type L05
March 2006	V2.8	all	Introduction of Sensirion USA address, updated disclaimer
March 2006	V2.9	2,6	New Calibration temperature: 23°C. Change of barbs/ports diameter specification
October 2006	V3.0	1,8,9	RoHS statement, Introduction of revision history in this document
May 2008	V3.1	All	RoHS statement on page 3, New disclaimer on page 10, Contact addresses updated, Various small modifications, Inconsistency in Zero Pressure / Full Scale Output corrected
September 2008	V4.0	2-5,8	SDP2000-R discontinued, new SDP1000-L025 implemented, power consumption, power supply dependence and temperature dependence changed due to new SF04 sensor chip version, article number index counted up due to new sensor chip version. Small linguistic adaptations.

Notes:

Important Notices

Warning, personal injury

Do not use this product as safety or emergency stop devices or in any other application where failure of the product could result in personal injury (including death). Do not use this product for applications other than its intended and authorized use. Before installing, handling, using or servicing this product, please consult the data sheet and application notes. Failure to comply with these instructions could result in death or serious injury.

If the Buyer shall purchase or use SENSIRION products for any unintended or unauthorized application, Buyer shall defend, indemnify and hold harmless SENSIRION and its officers, employees, subsidiaries, affiliates and distributors against all claims, costs, damages and expenses, and reasonable attorney fees arising out of, directly or indirectly, any claim of personal injury or death associated with such unintended or unauthorized use, even if SENSIRION shall be allegedly negligent with respect to the design or the manufacture of the product.

ESD Precautions

The inherent design of this component causes it to be sensitive to electrostatic discharge (ESD). To prevent ESD-induced damage and/or degradation, take customary and statutory ESD precautions when handling this product.

See application note "ESD, Latchup and EMC" for more information.

Warranty

SENSIRION warrants solely to the original purchaser of this product for a period of 12 months (one year) from the date of delivery that this product shall be of the quality, material and workmanship defined in SENSIRION's published specifications of the product. Within such period, if proven to be defective, SENSIRION shall repair and/or replace this product, in SENSIRION's discretion, free of charge to the Buyer, provided that:

- notice in writing describing the defects shall be given to SENSIRION within fourteen (14) days after their appearance;
- such defects shall be found, to SENSIRION's reasonable satisfaction, to have arisen from SENSIRION's faulty design, material, or workmanship;
- the defective product shall be returned to SENSIRION's factory at the Buyer's expense; and

- the warranty period for any repaired or replaced product shall be limited to the unexpired portion of the original period.

This warranty does not apply to any equipment which has not been installed and used within the specifications recommended by SENSIRION for the intended and proper use of the equipment. EXCEPT FOR THE WARRANTIES EXPRESSLY SET FORTH HEREIN, SENSIRION MAKES NO WARRANTIES, EITHER EXPRESS OR IMPLIED, WITH RESPECT TO THE PRODUCT. ANY AND ALL WARRANTIES, INCLUDING WITHOUT LIMITATION, WARRANTIES OF MERCHANTABILITY OR FITNESS FOR A PARTICULAR PURPOSE, ARE EXPRESSLY EXCLUDED AND DECLINED.

SENSIRION is only liable for defects of this product arising under the conditions of operation provided for in the data sheet and proper use of the goods. SENSIRION explicitly disclaims all warranties, express or implied, for any period during which the goods are operated or stored not in accordance with the technical specifications.

SENSIRION does not assume any liability arising out of any application or use of any product or circuit and specifically disclaims any and all liability, including without limitation consequential or incidental damages. All operating parameters, including without limitation recommended parameters, must be validated for each customer's applications by customer's technical experts. Recommended parameters can and do vary in different applications.

SENSIRION reserves the right, without further notice, (i) to change the product specifications and/or the information in this document and (ii) to improve reliability, functions and design of this product.

Copyright© 2001-2008, SENSIRION.

CMOSens® is a trademark of Sensirion

All rights reserved

RoHS and WEEE Statement

The SDP1000 family complies with requirements of the following directives:

- EU Directive 2002/96/EC on waste electrical and electronic equipment (**WEEE**), OJ13.02.2003; esp. its Article 6 (1) with Annex II.
- EU Directive 2002/95/EC on the restriction of the use of certain hazardous substances in electrical and electronic equipment (**RoHS**), OJ 13.02.2003; esp. its Article 4.

Headquarters and Sales Offices

Sensirion AG
Laubisruetistrasse 50
CH-8712 Staefa ZH
Switzerland

Phone: + 41 44 306 40 00
Fax: + 41 44 306 40 30
e-mail: info@sensirion.com
Web: www.sensirion.com



SENSIRION Inc
Westlake Pl. Ctr. I, suite 240
2801 Townsgate Road
Westlake Village, CA 91361
USA

Phone: +1 805-409 4900
Fax: +1 805-435 0467
e-mail: michael.karst@sensirion.com
Web: www.sensirion.com

Sensirion Korea Co. Ltd.
#1414, Anyang Construction Twr B/D
1112-1, Bisan-dong, Anyang-city
Gyeonggi-Province,
South Korea

Phone: +82 31-440-9925~27
Fax: +82 31-440-9927
e-mail: info@sensirion.co.kr
Web: www.sensirion.co.kr

SENSIRION Japan
Sensirion Japan Co. Ltd.
Shinagawa Station Bldg. 7F
4-23-5 Takanawa
Minato-ku, Tokyo, Japan

phone: +81 3-3444-4940
fax: +81 3-3444-4939
e-mail: info@sensirion.co.jp
Web: www.sensirion.co.jp