



Features

- Self-contained Class 1 or Class 2 modulated visible laser diode emitters permit higher gain than LEDs and extended range in opposed-mode sensing systems.
- Narrow effective beam provides small-object detection and precise position control.
- Bright spot and multiple shapes provide great visual marking of objects.
- 10 to 30V dc operation; third wire extinguishes laser light when connected to +V correct dc.

Models

Models*	Laser Class	Laser Spot Shape	Supply Voltage	Excess Gain** at 15 m (50')	Typical Beam Size	
QS186LE	Class 1	Small Spot	10 to 30V dc	With receiver Q23SN6R: 7500 With receiver SM31RL: 340 With receiver QS18VN6R: 4500 With receiver VS3AN5R: 2100 With receiver VS2AN5R: 1100	See Figure 2	
QS186LE10		Circle		—		
QS186LE11		Vertical Line		—		
QS186LE12		Horizontal Line		—		
QS186LE14		Cross		—		
QS186LE2	Class 2	Small Spot		10 to 30V dc	With receiver Q23SN6R: 12200 With receiver SM31RL: 1200 With receiver QS18VN6R: 7000 With receiver VS3AN5R: 5500 With receiver VS2AN5R: 3600	See Figure 4
QS186LE210		Circle			—	
QS186LE211		Vertical Line			—	
QS186LE212		Horizontal Line			—	
QS186LE214		Cross	—			

*Standard 2 m (6.5') cable models are listed.

• 9 m (30') cable: add suffix "W/30" to the model number (e.g., QS18LE W/30).

• 4-pin Pico-style pigtail QD models: add suffix "Q" (e.g., QS18LEQ).

• 4-pin integral Pico-style QD models: add suffix "Q7" (e.g., QS18LEQ7).

QD models require a mating cordset; see page 7.

• 4-pin Euro-style pigtail QD models: add suffix "Q5" (e.g., QS18LEQ5).

• 4-pin integral Euro-style QD models: add suffix "Q8" (e.g., QS18LEQ8).

**Not recommended for dusty or dirty environments; the scattered light would greatly reduce excess gain.

WARNING . . . Not To Be Used for Personnel Protection

Never use these products as sensing devices for personnel protection. Doing so could lead to serious injury or death.

These sensors do NOT include the self-checking redundant circuitry necessary to allow their use in personnel safety applications. A sensor failure or malfunction can cause either an energized or de-energized sensor output condition. Consult your current Banner Safety Products catalog for safety products which meet OSHA, ANSI and IEC standards for personnel protection.



WORLD BEAM QS186LE Laser Emitter

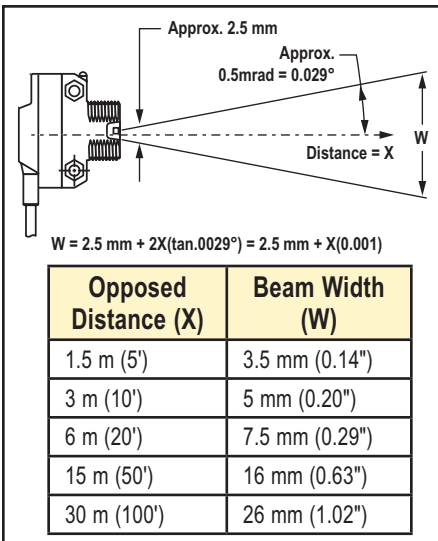

Figure 1. QS186LE laser emitter beam divergence at 25°C

Alignment

Conventional modulated infrared LED photoelectric emitters are designed with beam divergence angles of several degrees. As a result, most emitters are easily aligned to their receivers by simple line-of-sight methods.

The beam widths listed in Figure 1 are also the effective beam sizes at the receiver for model QS186LE. The effective beam size is equal to the minimum opaque object profile required to block the laser beam. The beam size at the emitter is 2.5 mm (0.1") diameter. Beam sizes at various distances for other models are shown in the tables below.

The effect of angular misalignment is dramatic (see Figure 3). The wide beam angles offered by conventional photoelectric emitters allow several degrees of misalignment between the optical axes of the emitter and receiver. This is not true for laser emitters, which require the beam center to directly strike the receiver lens. Figure 3 shows how far the laser beam will miss the center of the receiver lens for one degree of angular misalignment (in any plane). Note that even at a 5' range, one degree of misalignment will cause the laser beam to miss the lens of most receivers.

Small Spot (Model QS186LE)							
Distance	1.5 m (5')	3 m (10')	6 m (20')	15 m (50')	30 m (100')	—	—
Spot Size	3.5 mm (0.14")	5 mm (0.2")	7.5 mm (0.29")	16 mm (0.63")	26 mm (1.02")	—	—
Circle* (Model QS186LE10)							
Distance	0.4 m (1.3')	0.8 m (2.6')	1 m (3.3')	2 m (6.6')	3 m (10')	4 m (13')	5 m (16')
Circle Diameter	16 mm (0.63")	32 mm (1.26")	40 mm (1.57")	82 mm (3.23")	120 mm (4.72")	158 mm (6.22")	196 mm (7.72")
Vertical Line** (Model QS186LE11)							
Distance	0.2 m (0.6')	0.4 m (1.3')	0.6 m (1.9')	0.8 m (2.6')	1 m (3.3')	1.5 m (5')	2 m (6.6')
Line Size	80 x 3 mm (3.1" x 0.1")	145 x 3 mm (5.7" x 0.1")	210 x 3 mm (8.3" x 0.1")	270 x 3 mm (10.6" x 0.1")	330 x 3 mm (13.0" x 0.1")	480 x 3 mm (18.9" x 0.1")	600 x 3 mm (23.6" x 0.1")
Horizontal Line** (Model QS186LE12)							
Distance	0.2 m (0.6')	0.4 m (1.3')	0.6 m (1.9')	0.8 m (2.6')	1 m (3.3')	1.5 m (5')	2 m (6.6')
Line Size	95 x 2 mm (3.7" x 0.1")	175 x 2 mm (6.9" x 0.1")	252 x 2 mm (9.9" x 0.1")	333 x 2.5 mm (13.1" x 0.1")	418 x 2.5 mm (16.5" x 0.1")	613 x 3 mm (24.1" x 0.1")	765 x 3 mm (30.1" x 0.1")
Cross* (Model QS186LE14)							
Distance	0.4 m (1.3')	0.8 m (2.6')	1 m (3.3')	2 m (6.6')	3 m (10')	4 m (13')	5 m (16')
Line Size	60 mm (2.4")	125 mm (4.9")	155 mm (6.1")	310 mm (12.2")	460 mm (18.1")	615 mm (24.2")	760 mm (29.9")

*May contain a small collimated spot in the center of the pattern. For best focus, view circle at distances greater than 1 meter and cross at distances greater than 0.3 m (image is not crisp at closer distances).

**Light distribution is non-uniform, having less light at ends. The horizontal line is more uniform than the vertical line.

Figure 2. Typical Beam Size vs. Distance, Class 1 lasers

WORLD BEAM QS186LE Laser Emitter

Alignment Tip: The visible red beam of the laser emitter is easily seen in subdued lighting. At opposed distances of up to 10', attach a sheet of white paper directly in front of the receiver lens and mark the location of the lens center on the paper. Using the mark as an aiming target, sight along the beam from directly behind the laser emitter. Adjust the emitter mounting until the dot of red light is centered exactly on the mark. Remove the paper and check the response of the receiver.

For longer distances (up to 25'), replace the white paper with a 4" x 4" square of high-grade retroreflective tape (Banner model BRT-THG-4X4-5 or equivalent; see Figure 5). For greater distances, use a larger sheet of retroreflective material (see page 6).

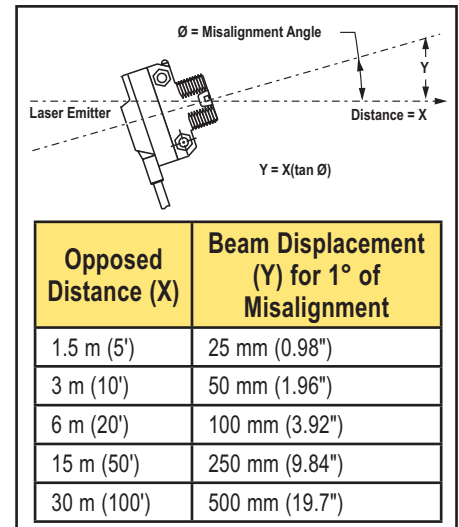

Figure 3. Beam displacement per degree of misalignment

Small Spot (Model QS186LE2)							
Distance	1.5 m (5')	3 m (10')	6 m (20')	15 m (50')	30 m (100')	—	—
Spot Size	3.8 mm (0.15")	5.1 mm (0.2")	10.2 mm (0.4")	17.8 mm (0.7")	30.5 mm (1.2")	—	—
Circle* (Model QS186LE210)							
Distance	0.4 m (1.3')	0.8 m (2.6')	1 m (3.3')	2 m (6.6')	3 m (10')	4 m (13')	5 m (16')
Circle Diameter	17.8 mm (0.7")	33 mm (1.3")	41.9 mm (1.65")	82.3 mm (3.25")	122 mm (4.8")	160 mm (6.3")	198 mm (7.8")
Vertical Line** (Model QS186LE211)							
Distance	0.2 m (0.6')	0.4 m (1.3')	0.6 m (1.9')	0.8 m (2.6')	1 m (3.3')	1.5 m (5')	2 m (6.6')
Line Size	72.1 x 2.5 mm (2.8" x 0.1")	150 x 2.5 mm (5.9" x 0.1")	208 x 2.5 mm (8.2" x 0.1")	284 x 2.5 mm (11.2" x 0.1")	350 x 2.5 mm (13.8" x 0.1")	502 x 2.5 mm (19.8" x 0.1")	660 x 2.5 mm (26" x 0.1")
Horizontal Line** (Model QS186LE212)							
Distance	0.2 m (0.6')	0.4 m (1.3')	0.6 m (1.9')	0.8 m (2.6')	1 m (3.3')	1.5 m (5')	2 m (6.6')
Line Size	74 x 2.5 mm (2.9" x 0.1")	159 x 2.5 mm (6.25" x 0.1")	224 x 2.5 mm (8.8" x 0.1")	330 x 2.5 mm (13" x 0.1")	406 x 2.5 mm (16" x 0.1")	610 x 2.5 mm (24" x 0.1")	800 x 2.5 mm (31.5" x 0.1")
Cross* (Model QS186LE214)							
Distance	0.4 m (1.3')	0.8 m (2.6')	1 m (3.3')	2 m (6.6')	3 m (10')	4 m (13')	5 m (16')
Line Size	61 mm (2.4")	125 mm (4.9")	155 mm (6.1")	312 mm (12.3")	467 mm (18.4")	620 mm (24.4")	760 mm (29.9")
*May contain a small collimated spot in the center of the pattern. For best focus, view circle at distances greater than 1 meter and cross at distances greater than 0.3 m (image is not crisp at closer distances).							
**Light distribution is non-uniform, having less light at ends. The horizontal line is more uniform than the vertical line.							

Figure 4. Typical Beam Size vs. Distance, Class 2 lasers

WORLD BEAM QS186LE Laser Emitter

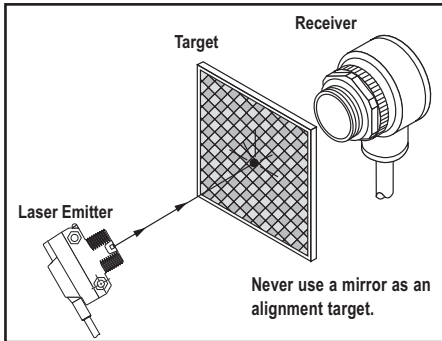

Figure 5. At long distances, use retroreflective tape to locate the beam at the desired location.

CAUTION

Use of controls or adjustments or performance of procedures other than those specified herein may result in hazardous radiation exposure; per EN 60825. **DO NOT attempt to disassemble this sensor for repair.** A defective unit must be returned to the manufacturer.

Description of Class 1 and Class 2 Lasers

Class 1

Lasers that are safe under reasonably foreseeable conditions of operation, including the use of optical instruments for intrabeam viewing.

Reference 60825-1 Amend. 2 © IEC:2001(E), section 8.2.

Class 1 Laser Characteristics:

Wavelength = 650 nm
Pulse Power \leq 1.9 milliwatts
Pulse Width = 5 microseconds
Rep Rate = 27 microseconds

CLASS 1 LASER PRODUCT

Complies with 21 CFR 1040.10 and 1040.11 except for deviations pursuant to Laser Notice No. 50, dated 7-26-01.

BANNER

Class 2

Low-power lasers are by definition incapable of causing eye injury within the duration of the blink (aversion response) of 0.25 seconds. They also must emit only visible wavelengths (400–700 nm). Therefore, an ocular hazard can exist only if an individual overcomes their natural aversion to bright light and stares directly into the laser beam.

For safe laser use:

- Do not permit a person to stare at the laser from within the beam.
- Do not point the laser at a person's eye at close range.
- The beam emitted by a Class 2 laser product should be terminated at the end of its useful path. Open laser beam paths should be located above or below eye level where practical.

Class 2 Laser Characteristics:

Wavelength = 650 nm
Pulse Power \leq 4.8 milliwatts
Pulse Width = 5 microseconds
Rep Rate = 27 microseconds

Pulse Power < 4 mW, 645 - 665 nm, 35 kHz, 5.1 uS Pulse. Complies TO 21 CFR 1040.10 & EN60825-1:2001 except for deviations pursuant to laser notice No. 50, dated 7-26-01.

LASER LIGHT - DO NOT STARE INTO BEAM
CLASS 2 LASER PRODUCT



Installation

To mount the QS186LE into bracket models SMB18A or SMB46A, insert the laser emitter into the hole in the bracket, then tighten the hex jam nut to the bracket, so the emitter is held snugly in place. Mount the bracket using your own screws or bolts (SMB18A uses M4 or #8 screws or bolts; SMB46A uses M5 or #10), and check for alignment, as described on pages 2 and 3.

If using the adjustable bracket (model SMB46A), tighten or loosen one or two of the precision alignment screws (use the supplied 2 mm Allen wrench) until the laser is accurately aligned.

WORLD BEAM QS186LE Laser Emitter

Specifications

Supply Voltage and Current	10 to 30V dc (10% maximum ripple) at less than 35 mA	
Supply Protection Circuitry	Protected against reverse polarity	
Delay at Power Up	Class 1 Models: 250 ms	Class 2 Models: 10 ms
Sensing Beam	Class 1 Laser : 650 nm visible red (temperature coefficient 0.2 nm/° C) Pulse Width: 5 microseconds Rep Rate: 27 microseconds Pulse Output Power: less than 1.9 milliwatts	Class 2 Laser: 650 nm visible red (temperature coefficient 0.25 nm/° C) Pulse Width: 5 microseconds Rep Rate: 27 microseconds Pulse Output Power: less than 4.8 milliwatts
Laser Control	Apply 0V dc to white wire to enable beam Apply +10 to 30V dc to white wire to inhibit beam Class 1 Enable Time: 240 ms; 100 ms disable time	Apply 0V dc to white wire to enable beam Apply +10 to 30V dc to white wire to inhibit beam Class 2 Enable Time: 8 ms; 1 ms disable time
Indicators	Green LED, indicates power applied	
Construction	ABS housing, PMMA window 3 mm mounting hardware included	
Environmental rating	NEMA 6; IEC IP67; UL Type 1	
Connections	PVC-jacketed 2 m (6.5') attached cable, or 4-pin Euro-style quick-disconnect (QD) fitting	
Operating Conditions	Temperature: -10° to +50° C (+14° to 122° F) Max. Relative Humidity: 90% at 50° C (non-condensing)	
Laser Classification	Class 1 / Class 2 laser product; complies with 21 CFR 1040.10, EN60825-1:2001 except for deviations pursuant to Laser Notice 50, dated 7-26-01	
Certifications		

Dimensions

Cabled Models

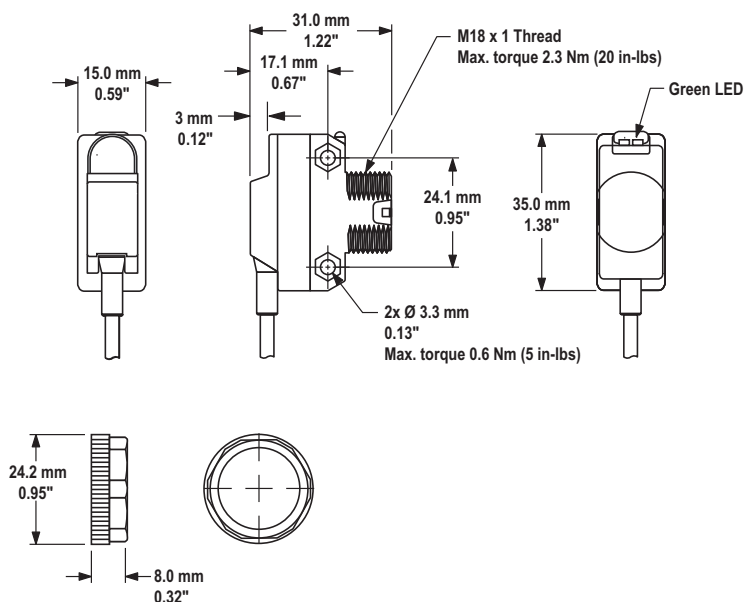

QD Models

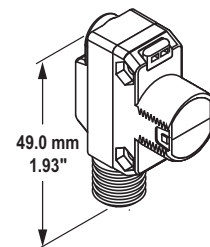

WORLD BEAM QS186LE Laser Emitter

Hookups

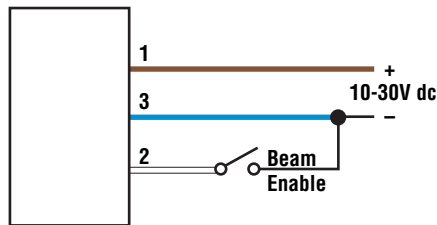

Key
 1 = Brown
 2 = White
 3 = Blue
 4 = Black†
 † Not Used

4-Pin Euro-Style Pinout (Cable Connector Shown)

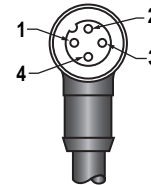

NOTE: Cable and QD hookups are functionally identical.

Accessories

Quick-Disconnect Cordsets

Style	Model	Length	Dimensions	Style	Model	Length	Dimensions
4-pin Euro-style straight	MQDC-406 MQDC-415 MQDC-430	2 m (6.5') 5 m (15') 9 m (30')		4-pin Pico-style straight	PKG4-2	2 m (6.5')	
4-pin Euro-style right-angle	MQDC-406RA MQDC-415RA MQDC-430RA	2 m (6.5') 5 m (15') 9 m (30')		4-pin Pico-style right-angle	PKW4-2	2 m (6.5')	

Retroreflective Tape

Used for laser alignment

Model	Reflectivity Factor	Maximum Temperature	Size	Unit	
BRT-THG-4X4-5	0.7	60° C (140° F)	100 x 100 mm (4" x 4")	Package of 5	
BRT-THG-8.5X11-2	0.7		216 x 280 mm (8.5" x 11")	Package of 2	
BRT-THG-18X36	0.7		457 x 914 mm (18" x 36")	Single Sheet	

WORLD BEAM QS186LE Laser Emitter

Mounting Brackets

SMB18A	<ul style="list-style-type: none"> • 12-gauge, stainless steel • Right-angle mounting bracket 	SMB312S	<ul style="list-style-type: none"> • Stainless steel • 2-axis, side-mounting bracket
<p>* Use 4 mm (#8) screws to mount bracket. Drill screw holes 24.2 mm (0.95") apart.</p>			
SMBQS18Y	<ul style="list-style-type: none"> • Die-cast bracket for mounting into 18 mm holes • Metal hex nut and lock washer included • Cabled units tilt $\pm 8^\circ$ • Bracket for P/N 68865 	SMB46A	<ul style="list-style-type: none"> • Adjustable 2-piece, 12-gauge, stainless steel bracket assembly • Includes 2 mm hex key for precision adjustment
SMBQS18A	<ul style="list-style-type: none"> • Stainless steel • Wrap-around bracket 		

WORLD BEAM QS186LE Laser Emitter



WARRANTY: Banner Engineering Corp. warrants its products to be free from defects for one year. Banner Engineering Corp. will repair or replace, free of charge, any product of its manufacture found to be defective at the time it is returned to the factory during the warranty period. This warranty does not cover damage or liability for the improper application of Banner products. This warranty is in lieu of any other warranty either expressed or implied.

P/N 109415 rev. F

Banner Engineering Corp., 9714 Tenth Ave. No., Minneapolis, MN USA 55441 • Phone: 763.544.3164 • www.bannerengineering.com • Email: sensors@bannerengineering.com