

NAIS

**LONG RANGE TRIGONOMETRIC
AREA REFLECTIVE
PHOTOELECTRIC SENSORS
(AC OR DC POWER)**

MR3/MR3-T Series



FEATURES

Long range sensors.

The first long distance optical triangulation photoelectric sensors for 1 m 3.281 ft. and

2 m 6.562 ft. applications. Suitable for detection of passing targets and positioning.

New added type with timer functions.

The 3-mode (ON-delay, OFF-delay, One-shot) timer function is built-in the MR3-T type, to prevent detection errors and make it easier to send a high speed signal to a PC etc. The control time range is from 0.1 to 5 sec.

AC or DC power

The DC type operates by 12 to 24 V DC and the AC-DC type by 12 to 240 V DC or 24 to 240 V AC power supply. This allows operation voltages world wide.

Accurately detects objects, regardless of colors, materials and shapes.

Area reflective type sensor permits the detection of white and black targets at the same distance. Also targets with mixed colors, difficult to detect with standard diffuse reflective type sensors, can be detected.

Unaffected background objects.

Area reflective type sensors do not detect objects beyond the set point. False detection, caused by movement beyond detectable objects, does not occur.

Tolerates dirty lens with consistent position detection.

There is virtually no variation in the operation even if the lens surface becomes dirty. Position detection of targets approaching from the front is always constant.

Various outputs selectable

Two outputs are provided for the DC type, NPN and PNP output, so that a single photoelectric sensor can match the polarity of the power supply wiring. The output section of the AC/DC type contains compact 1 Form A contact rated 3 A, 250 V AC (resistive).

Designed for easy installation and adjustment.

- Screw terminals for easy wiring.
- One-touch switch for mode selection.

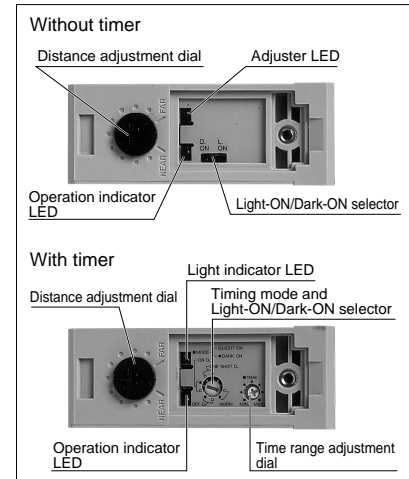

An output protection circuit is built-in the DC type.

Water protected construction (equivalent to IEC IP66).

APPLICATIONS

Detection of medium to large targets. Large product assembly lines, automatic vertical warehouses, personnel detection, etc.

SENSING RANGES

	Sensing range (m ft.)	
	1 3.281	2 6.562
MR3-M100 type	[Bar chart showing sensing range for MR3-M100 type]	
MR3-M200 type	[Bar chart showing sensing range for MR3-M200 type]	

PRODUCT TYPE

Detection method	Range	Rated operating voltage	Control output	Timer	Part number
Area reflective type	1 m 3.281 ft.	12 to 24 V DC	Transistor (NPN and PNP)	No	MR3-M100A-DC12-24V
				Yes	MR3-M100AT-DC12-24V
		12 to 240 V DC 24 to 240 V AC	1 from A relay (3 A 250 V AC)	No	MR3-M100P-12-240VCE
	Yes	MR3-M100PT-12-240VCE			
	2 m 6.562 ft.	12 to 24 V DC	Transistor (NPN-PNP)	No	MR3-M200A-DC12-24V
				Yes	MR3-M200AT-DC12-24V
12 to 240 V DC 24 to 240 V AC		1 from A relay (3 A 250 V AC)	No	MR3-M200P-12-240VCE	
Yes	MR3-M200PT-12-240VCE				

SPECIFICATIONS

DC type

1) Ratings

Type	Types without timer, MR3	Types with timer, MR3-T
Operating side	Rated operating voltage 12 to 24 V DC	
	Rated current consumption 55 mA or less (excluding load)	60 mA or less (excluding load)
Load side	Output current capacity 100 mA or less (NPN side), 100 mA or less (PNP side)	

2) Performance

Detection principle		Triangulation sensing method			
Detection method		Area reflective type			
Type		Amplifier selfcontained DC type without timer, MR3		Amplifier selfcontained DC type with timer, MR3-T	
Part number		MR3-M100A-DC12-24V	MR3-M200A-DC12-24V	MR3-M100AT-DC12-24V	MR3-M200AT-DC12-24V
Sensing range		1 m 3.281 ft.	2 m 6.562 ft.	1 m 3.281 ft.	2 m 6.562 ft.
Detectable distance		0.2 to 1 m .656 to 3.281 ft.	0.5 to 2 m 1.641 to 6.562 ft.	0.2 to 1 m .656 to 3.281 ft.	0.5 to 2 m 1.641 to 6.562 ft.
Standard target		White drawing paper: 20×20 cm 7.874×7.874 inches			
Detectable target		Opaque, translucent			
Hysteresis		10% or less of the set range			
Operating voltage range		9.6 to 30 V DC ripple (P-P) included			
Response time (freq.)		1 ms or less (500 times per second or less)			
Initial insulation resistance		20 MΩ or less between input/output and external housing (at 500 V DC)			
Initial breakdown voltage		Between input/output and external housing: 500 Vrms for 1 min			
Vibration resistance	Functional	10 to 55 Hz (1 cycle/min), double amplitude 1.5 mm .059 inch (10 min each on 3 axes)			
	Destructive	10 to 55 Hz (1 cycle/min), double amplitude 1.5 mm .059 inch (2 h each on 3 axes)			
Shock resistance	Functional	98 m/s ² {approx. 10 G} (6 times each on 3 axes)			
	Destructive	980 m/s ² {approx. 100 G} (6 times each on 3 axes)			
Protective construction		Plastic case, water-protected (equivalent to IEC IP66)			
Usable ambient light level	Incandescent lamp	3,000 lux or less			
	Sunlight	10,000 lux or less			
Ambient temperature		-25°C to 55°C -13°F to 131°F (non-icing condition)			
Ambient humidity		Max. 85% RH (non-condensing condition)			
Storage temperature		-30°C to 70°C -22°F to 158°F			
Indicator		Operation indicator LED (Light incident), Adjuster LED		Light indicator LED (Light incident), Operation indicator LED	
Light source		Infrared LED			
Timer functions	Time range	—		0.1 to 5 s	
	Operation mode	—		Normal, ON-delay, OFF-delay, One-shot	

Unless otherwise specified, the measurement conditions comprise rated operating voltage, power supply by battery, 20°C 68°F ambient temperature, standard target and 200 lux or less illuminance on the receiver surface.

3) Output circuit diagram

Types without timer, MR3

Circuit diagram

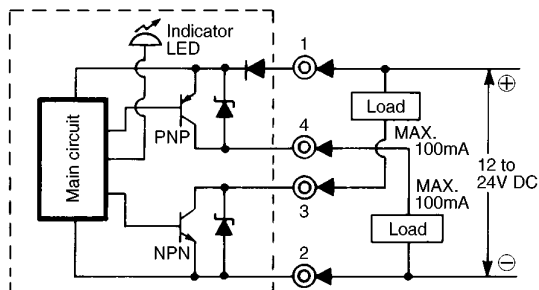

Types with timer, MR3-T

Circuit diagram

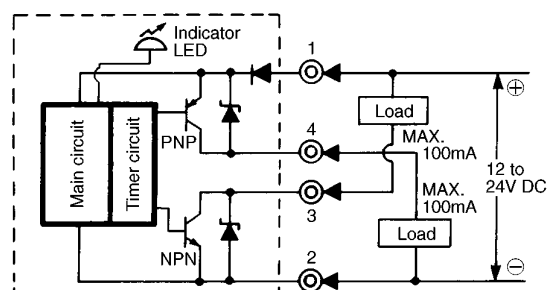

AC/DC type

1) Ratings

Type		Types without timer, MR3	Types with timer, MR3-T
Operating side	Rated operating voltage	12 to 240 V DC/24 to 240 V AC	
	Rated current consumption	DC: 3 W or less ; AC: 4 VA or less	DC: 4 W or less ; AC: 5 VA or less
Load side	Output current capacity	3 A 250 V AC (resistive)	

2) Performance

Detection principle		Triangulation range measurement method			
Detection method		Area reflective type			
Type		Amplifier selfcontained AC/DC type without timer , MR3		Amplifier selfcontained AC/DC type with timer, MR3-T	
Part number		MR3-M100P-12-240VCE	MR3-M200P-12-240VCE	MR3-M100PT-12-240VCE	MR3-M200PT-12-240VCE
Sensing range		1 m 3.281 ft.	2 m 6.562 ft.	1 m 3.281 ft.	2 m 6.562 ft.
Detectable distance		0.2 to 1 m .656 to 3.281 ft.	0.5 to 2 m 1.641 to 6.562 ft.	0.2 to 1 m .656 to 3.281 ft.	0.5 to 2 m 1.641 to 6.562 ft.
Standard target		White drawing paper: 20×20 cm 7.874×7.874 inches			
Detectable target		Opaque, translucent			
Hysteresis		10% or less of the set range			
Operating voltage range		10.8 to 264 V DC/21.6 to 264 V AC			
Response time (freq.)		20 ms or less (25 times per second or less)			
Initial insulation resistance		100 MΩ or more (at 500 V DC) between live terminal and dead metal parts between live terminal and contact between live contact and dead metal parts between open contacts			
Initial breakdown voltage		Between live terminal and dead metal parts: 2,000 Vrms for 1 min Between live terminal and contact: 2,000 Vrms for 1 min Between contact and dead metal parts: 2,000 Vrms for 1 min Between open contacts: 1,000 Vrms for 1 min			
Vibration resistance	Functional	10 to 55 Hz (1 cycle/min), double amplitude 1.5 mm .059 inch (10 min each on 3 axes)			
	Destructive	10 to 55 Hz (1 cycle/min), double amplitude 1.5 mm .059 inch (2 h each on 3 axes)			
Shock resistance	Functional	98 m/s ² {approx. 10 G} (3 times each on 3 axes)			
	Destructive	980 m/s ² {approx. 100 G} (3 times each on 3 axes)			
Protective construction		Plastic case, water-protected (equivalent to IEC IP66)			
Usable ambient light level	Incandescent amp	3,000 lux or less			
	Sunlight	10,000 lux or less			
Ambient temperature		-25°C to 55°C -13°F to 131°F (non-icing condition)			
Ambient humidity		Max. 85% RH (non-condensing condition)			
Storage temperature		-30°C to 70°C -22°F to 158°F			
Indicator		Operation indicator LED (Light incident), Adjuster LED		Light indicator LED (Light incident), Operation indicator LED	
Light source		Infrared LED			
Timer function	Time range	—		0.1 to 5 s	
	Operation mode	—		Normal, ON-delay, OFF-delay, One-shot	
Output	Contact arrangement	1 Form A			
	Initial contact resistance (By voltage drop 6 V DC 1 A)	100 mΩ or less			
	Contact material	Gold flash over silver alloy			
	Expected life (max.)	Electrical: 10 ⁶ times (20 cpm at rated load); Mechanical: 5×10 ⁷ times (20 cpm)			

Unless otherwise specified, the measurement conditions comprise rated operating voltage, 20°C 68°F ambient temperature, standard target and 200 lux or less illuminance on the receiver surface.

3) Output circuit diagram

Types without timer, MR3

Circuit diagram

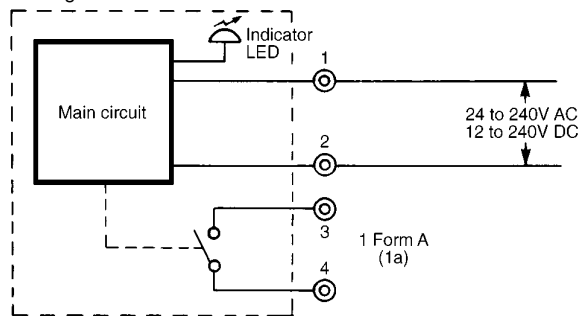

Types with timer, MR3-T

Circuit diagram

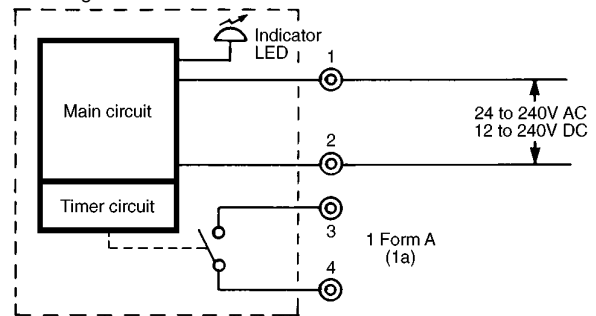

DATA

1. Operating range characteristics

MR3-M100 types

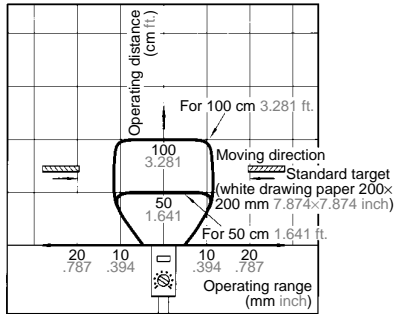

MR3-M200 types

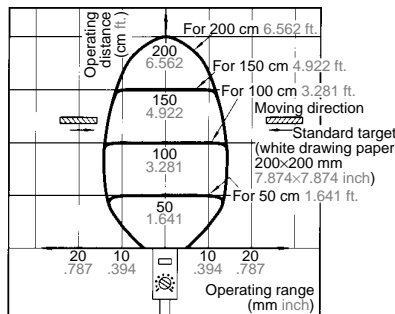

2. Projector beam diameter characteristics

MR3-M100 types

Light beam diameter is determined as the region where the amount of light is decreased to 1/e² (e ≈ 2.72) when the largest amount of light is assumed as 1.

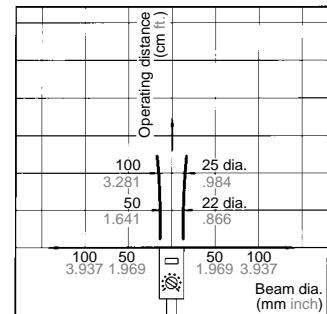

3. Sensing range and surface area characteristics

MR3-M200 types

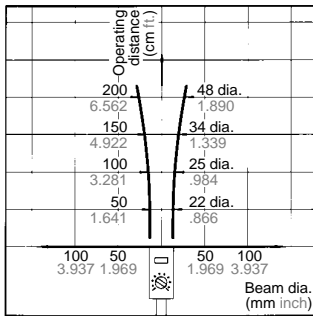

MR3-M100 types

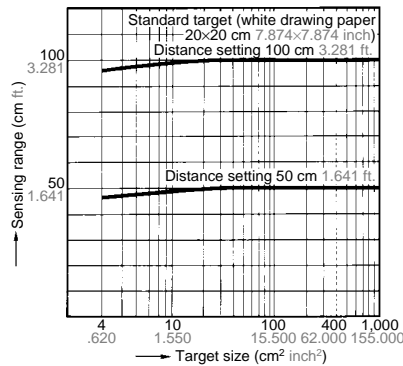

MR3-M200 types

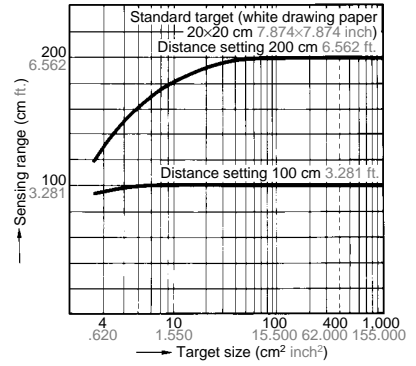

4. Material characteristics

MR3-M100 types

Condition: Target: 15x15 cm 5.906x5.906 inch natural shape

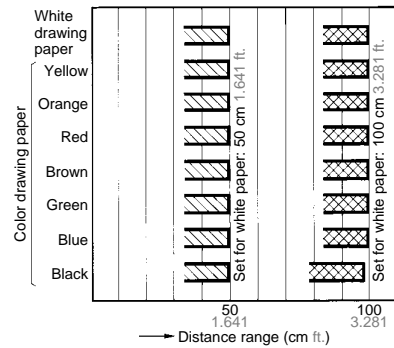

MR3-M200 types

Condition: Target: 15x15 cm 5.906x5.906 inch natural shape

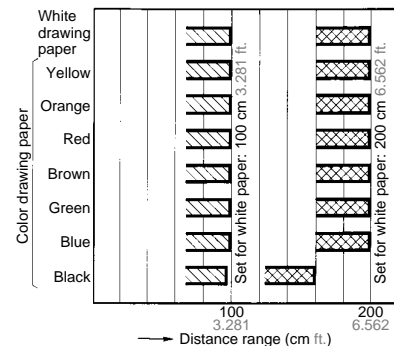

DIMENSIONS

MR3/MR3-T Photoelectric sensor



Outline dimensions

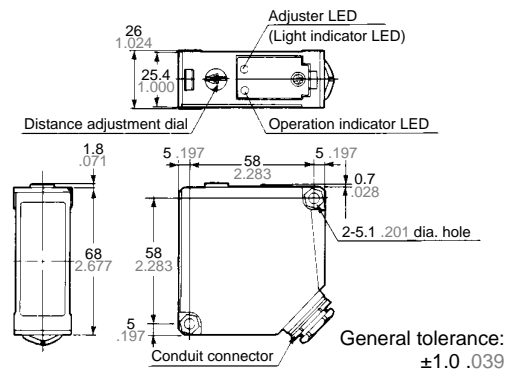

() denotes MR3-T timer type.

Dimensions with the mounting bracket attached.

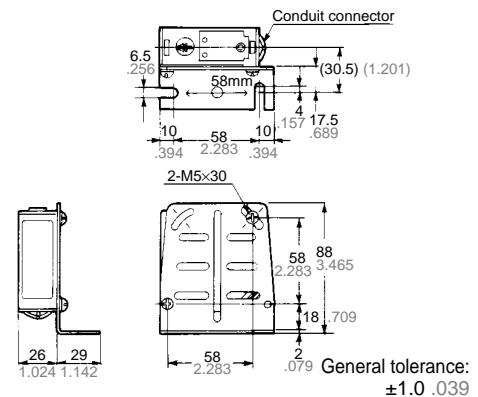

Note: The mounting bracket is enclosed in the inner carton.

General tolerance: ±1.0 .039

SCHEMATIC

DC TYPE

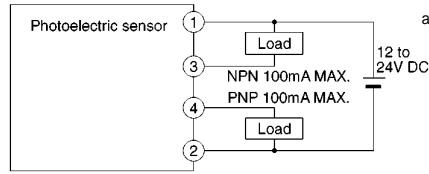

AC/DC TYPE

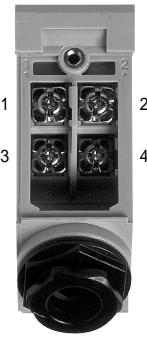
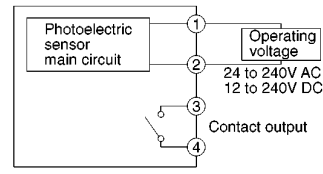

Note: Ground the frame ground terminal and ground terminal when using a switching power supply. This will ensure stable operation.

DISTANCE ADJUSTMENT

- 1) Point the detection surface of the photoelectric sensor in the direction to detect and temporarily fasten.
- 2) Set the distance adjustment dial to its maximum setting FAR. Slowly turn it counterclockwise without an object present and note the position where the operation (light) indicator LED turns OFF. The maximum position at which the LED turns off is the FAR position.
- 3) Place a target at the detection position and set the distance adjustment dial to its minimum setting NEAR. Slowly turn it clockwise and note the operation (light) indicator LED turns ON. The minimum position at which the LED turns ON is the NEAR position.
- 4) Set the distance adjustment dial to the middle of the two positions found in step 2) and step 3) before.

- 5) Fasten the photoelectric sensor. Mount securely so that the photoelectric sensor is not shifted from alignment by vibrations or impact.

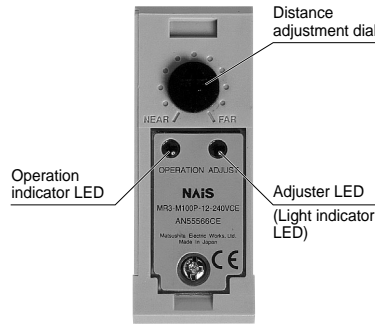

For the MR3-T timer type, see the words in the ().

Notes

1. If the adjuster LED does not turn ON in 4) (note that there is no adjuster LED for the MR3-T timer type), or if the position LED for the distance adjustment dial in 2) (or 3) is less than 2 graduations, either change the position of the detection surface and repeat 1) to 4), or adjust external factors such as ambient temperature variations, position of target, etc.
2. The detection distance varies only slightly with the color of the target. However, if the target has extremely low reflection factor (mirrors, glass, glossy paper and other specular reflective objects), adjustment of the detectable distance may not be applied to the distance adjustment dial, otherwise it may be damaged.

TIMING FUNCTIONS FOR MR3-T TIMER TYPE

1) Timing operation

Control output mode	Timing mode (Timing mode selector *1)	Detection state	Timing functions
Light-ON mode	Normal mode ①	Light entry → ON → Light blocked → OFF	—
	ON-delay mode ⑤	Light entry → ON (delay T) → OFF	Inhibits control output for the set time (Ts)
	OFF-delay mode ③	Light entry → ON → OFF (delay T) → ON	The control output stays ON for the set time (Ts) after detection is over.
	One-shot mode ⑦	Light entry → ON (delay T) → OFF	The control output is ON for the set time (Ts) after detection.
Dark-ON mode	Normal mode ②	Light blocked → OFF → Light entry → ON	—
	ON-delay mode ⑥	Light blocked → OFF (delay T) → ON	The control output is inhibited OFF for the set time after detection is over.
	OFF-delay mode ④	Light blocked → OFF → ON (delay T) → OFF	The control output is stays OFF for the set time (Ts) after detection.
	One-shot mode ⑧	Light blocked → OFF (delay T) → ON	The control output is ON for the set time (Ts) after detection is over.

*1: See "Timing mode and Light-ON/Dark-ON selector" below.

Notes: 1) Timing range: T 0.1s to 5s

2) During the normal mode, the time range adjustment dial should be set to MIN position.

2) Timing mode and Light-ON/Dark-ON selector

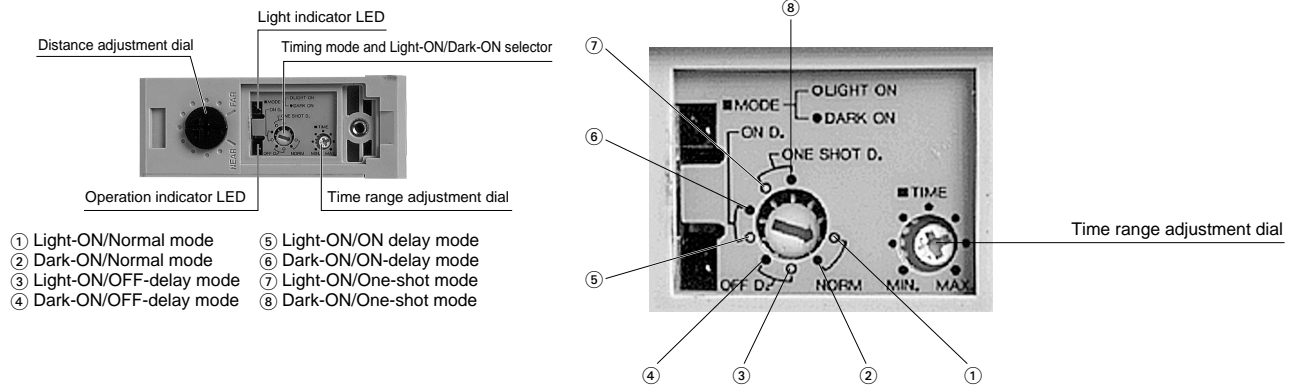

CAUTIONS



1. Operating Environment

- 1) The sensor should be used in an ambient temperature range of -25 to $+55^{\circ}\text{C}$ -13 to $+131^{\circ}\text{F}$.
- 2) Use an operating voltage in the range of 9.6V to 30 V DC (includes peak to peak ripple) for the DC types and 21.6V to 264V AC or 10.8V to 264V DC for the AC/DC types.
- 3) The light intensity on the receiver surface should be less than 3,000 lux for an incandescent light source and less than 10,000 lux for sunlight.
- 4) Use a surge absorber as the internal circuit may be damaged if external surge voltages exceed 5..V (for DC type)/4,000V (for AC/DC type) $[\pm(1.2 \times 50)\mu\text{s}]$ signal polarity full-wave voltage].

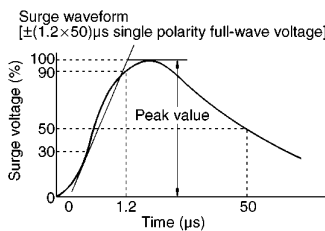

- 5) Avoid use in locations with high concentrations of steam, dust, corrosive gases, etc.
- 6) Use a load relay with a rated operating voltage of 12V DC or 24V DC for the DC types. The voltage applied to the load relay is the operating voltage of the photoelectric sensor minus the internal voltage drop (maximum 1.2V NPN side, 2V PNP side). Voltage fluctuations should be taken into account.
- 7) The output circuit of the DC type contains a short-circuit protection circuit. When controlling loads with a large inrush current, such as capacitive loads, be sure the inrush current does not exceed the maximum output current

capacity. If the short-circuit is activated, it can be reset either by turning the power off and then turning it back on, or by ON/OFF operation.

2. Wiring

- 1) Check all wiring before applying power since incorrect wiring may damage the internal circuit.
- Also, carefully tighten the terminal screws so that the wires of adjacent terminals do not touch.
- 2) Although any cable can be used, a round cable with a smooth surface and an outside diameter of 9 to 11 mm $.354$ to $.433$ inch should be used and the cable connector (supplied) shall be tightened correctly to maintain watertight performance. Use a tightening torque of 15 to 20 N·m $\{147$ to 196 kgf·cm 127.60 to 170.03 lbf·in $\}$.
- 3) the conduit inlet accepts PF1/2 threads.
- 4) If crimp terminals are used, crimp the terminals and then secure with the terminal (M3.5) screws.
- 5) Tighten the terminal screws with a maximum torque of 5 N·m $\{49$ kgf·cm 42.53 lbf·in $\}$.
- 6) Ground the frame ground (FG) terminal and ground (G) terminal when using a commercially available switching regulator. If a ground is not connected, switching noise from the power supply may result in faulty operation.
- 7) Wire 0.3 mm 2 0.005 inch 2 AWG22 or larger should be used for wiring up to a length of 100 m 328 ft.

3. Detector

- 1) Keep the detector surface clean as excessive dust or dirt on the detector surface will decrease the margin of the distance range.
- 2) The front surface of the lens and case are made of polycarbonate resin. Although it withstands water, weak acids and alkalines, aliphatic hydrocarbons, and oils and fats, it is not resistant to ketones, esters, halogenated hydrocarbons and aromatic hydrocarbons.

4. Movement Direction of the target

Take care with the mounting direction of the photoelectric sensor with respect to the movement direction of the target.

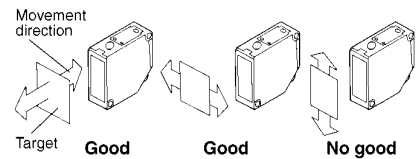

5. Other cautions

- 1) When using the supplied mounting bracket, tighten the mounting screws with a maximum torque of 8 N·m $\{78.4$ kgf·cm 68.00 lbf·in $\}$. If the supplied mounting bracket is not used, mount the sensor on a flat surface.
- 2) Using a torque of 3 to 5 N·m $\{29.4$ to 42.53 kgf·cm 25.48 to 42.53 lbf·in $\}$, tighten the terminal cover and display cover screws to maintain watertight performance.

USABLE CRIMP TERMINAL DIMENSIONS

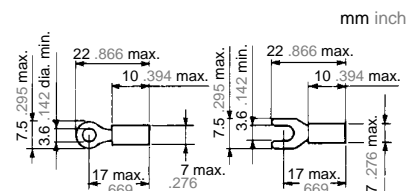

CABLE CONNECTOR CONSTRUCTION AND CABLE PREPARATION

