



Actual size

ML4.1 Series Sub-Miniature Style Sensors

- Space-saving 14mm (9/16") wide housing
- Dual selectable outputs, PNP or NPN
- Light on/dark on mode determined by wiring
- LED indication of switch status and signal strength



Diffused Mode with Background Suppression

See pages 332-333

Features:

- Ignores background machine surfaces
- Consistent detection of light and dark objects

Sensing Ranges: 20mm, 40mm, 60mm, 80mm

Output: Push-pull

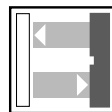

Diffused Mode

See page 333

Features:

- Visible red alignment aid
- Adjustable sensing range

Sensing Range: 400mm

Output: Push-pull

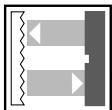

Retro-Reflective Mode

See page 334

Features:

- Reliable detection of even the shiniest materials
- Single lens allows for close placement of reflector

Sensing Range: 400mm

Output: Push-pull

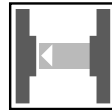

Thru-Beam Mode

See page 334

Features:

- Test input on transmitter for added control
- Detects 9mm (3/8") diameter targets

Sensing Range: 2.5m

Output: Push-pull

See pages 335-336 for ML4.1 series specifications, wiring and dimensions.

Photoelectric Sensors



Diffused Mode with Background Suppression

Specifications	7-20mm	10-40mm	10-60mm	10-80mm
SENSING RANGE	7-20mm	10-40mm	10-60mm	10-80mm
SENSITIVITY ADJUSTMENT	No	No	No	No
BACKGROUND SUPPRESSION	from 25mm	from 50mm	from 80mm	from 100mm
BLACK/WHITE DIFFERENTIAL*	1mm	3mm	20mm (-RT)/10mm (-IR)	20mm
MODEL NUMBER(S)	ML4.1-8-H-20-RT/95/110	ML4.1-8-H-40-RT/95/110	ML4.1-8-H-60-RT/95/110	—
	ML4.1-8-H-20-IR/95/110	ML4.1-8-H-40-IR/95/110	ML4.1-8-H-60-IR/95/110	ML4.1-8-H-80-IR/95/110
OUTPUT: Transistor, Normally Open or Normally Closed	Push-pull	Push-pull	Push-pull	Push-pull
SUPPLY VOLTAGE	10-30VDC	10-30VDC	10-30VDC	10-30VDC
LIGHT SPOT DIAMETER	3mm	4mm	6mm (-RT)/5mm (-IR)	6mm
LIGHT BEAM ANGLE	≈8°	≈6°	≈6°	≈6°
LIGHT SOURCE	-RT	Visible red LED 635nm	Visible red LED 635nm	Visible red LED 635nm
	-IR	Infrared LED 880nm	Infrared LED 880nm	Infrared LED 880nm
AMBIENT LIGHT RESISTANCE	≤100,000 lux	≤100,000 lux	≤100,000 lux	≤100,000 lux
ELECTRICAL CONNECTION	Quick disconnect type V31	Quick disconnect type V31	Quick disconnect type V31	Quick disconnect type V31
ADDITIONAL DATA	<i>See pages 335-336</i>			

*Difference in sensing range between 90% white test card and 6% black test card

Sensing Characteristics

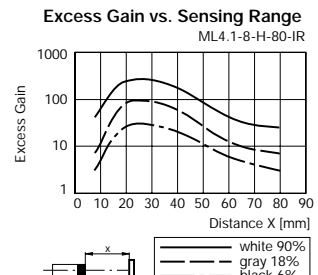
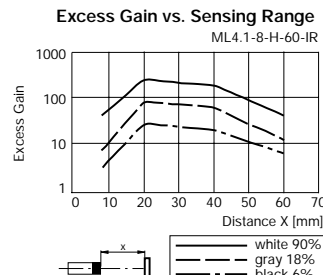
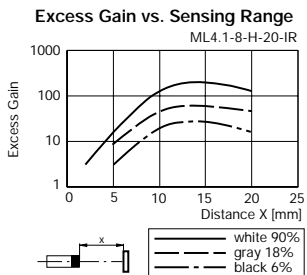
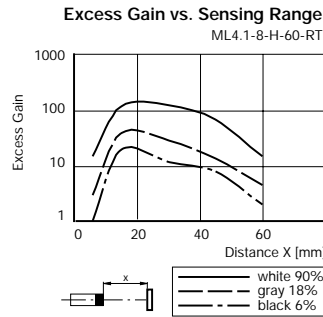
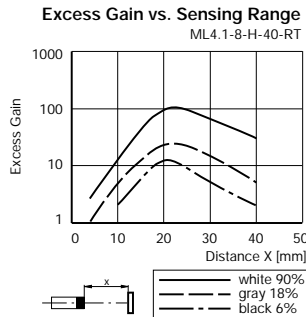
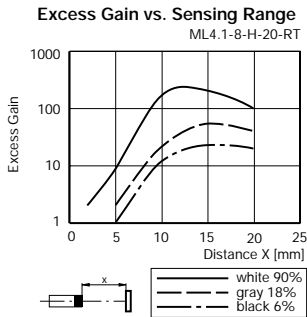

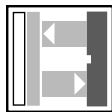

Diffused Mode with Background Suppression

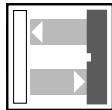
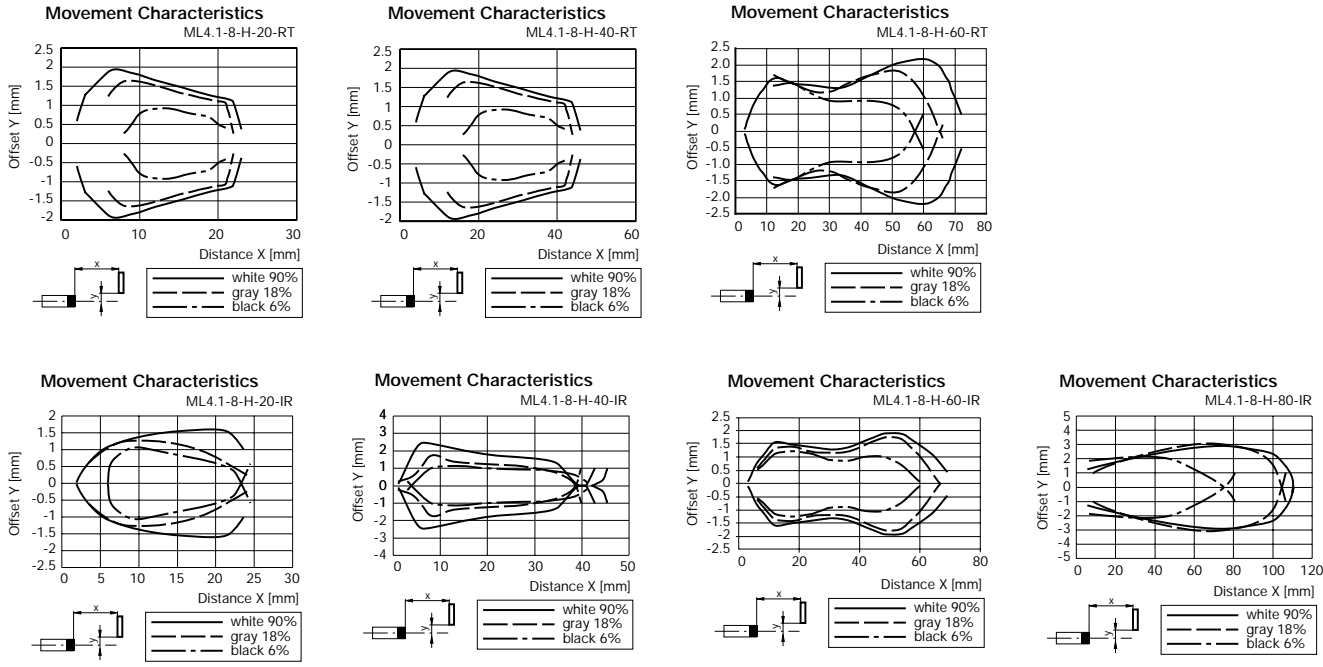

Diffused Mode

Specifications	
SENSING RANGE	0-400mm
SENSITIVITY ADJUSTMENT	Yes (150-400mm)
MODEL NUMBER(S)	M4.1-8-400/40b/95/110
OUTPUT: Transistor, Normally Open or Normally Closed	Push-pull
SUPPLY VOLTAGE	10-30VDC
LIGHT SPOT DIAMETER	80mm at a range of 400mm
LIGHT BEAM ANGLE	≈10°
LIGHT SOURCE	Visible red LED 635nm
AMBIENT LIGHT RESISTANCE	≤80,000 lux
ELECTRICAL CONNECTION	 Quick disconnect type V31
ADDITIONAL DATA	See pages 335-336

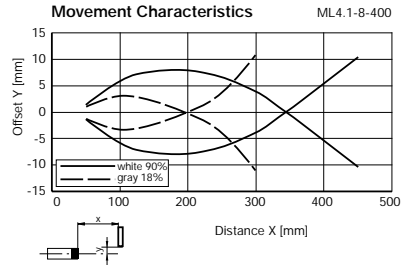
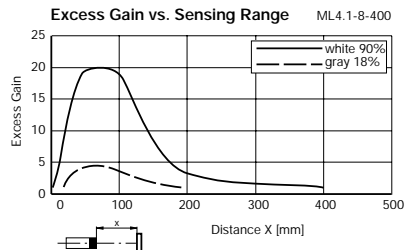

Sensing Characteristics

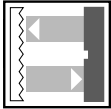

Photoelectric Sensors



Retro-Reflective Mode

Specifications		
SENSING RANGE	0-400mm	0-400mm
SENSITIVITY ADJUSTMENT	No	No
REFLECTOR DISTANCE	0-400mm	0-400mm
POLARIZED FILTER	Yes	Yes
MODEL NUMBER(S)	ML4.1-54-F/40b/95/110	ML4.1-54-F/82b/95/110
OUTPUT: Transistor, Normally Open or Normally Closed	Push-pull	Push-pull (and weak signal output)
SUPPLY VOLTAGE	10-30VDC	10-30VDC
LIGHT SPOT DIAMETER	20mm	20mm
LIGHT BEAM ANGLE	≈3°	≈3°
LIGHT SOURCE	Visible red LED 635nm	Visible red LED 635nm
AMBIENT LIGHT RESISTANCE	≤100,000 lux	≤100,000 lux
ELECTRICAL CONNECTION	 Quick disconnect type V31	 Quick disconnect type V31
ADDITIONAL DATA	<i>See pages 335-336</i>	

Sensing Characteristics

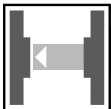
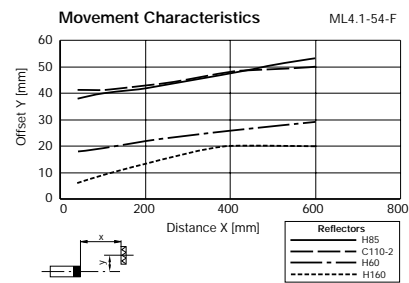
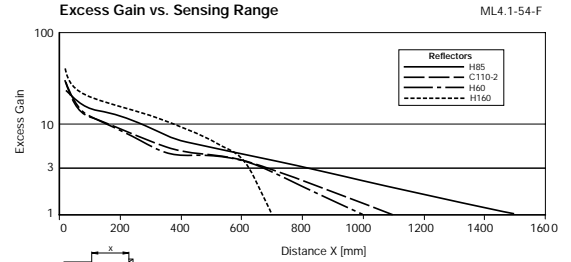

Thru-Beam Mode

Specifications	
SENSING RANGE	0-2.5m
SENSITIVITY ADJUSTMENT	Yes (0-2.5m)
MODEL NUMBER(S)	M4.1/MV4.1/40b/95/110
OUTPUT: Transistor, Normally Open or Normally Closed	Push-pull
SUPPLY VOLTAGE	10-30VDC
LIGHT SPOT DIAMETER	260mm at a range of 2.5m (9mm minimum target diameter)
LIGHT BEAM ANGLE	5° transmitter/15° receiver
LIGHT SOURCE	Visible red LED 635nm
AMBIENT LIGHT RESISTANCE	≤100,000 lux
ELECTRICAL CONNECTION	 Quick disconnect type V31
ADDITIONAL DATA	<i>See pages 335-336</i>

Sensing Characteristics

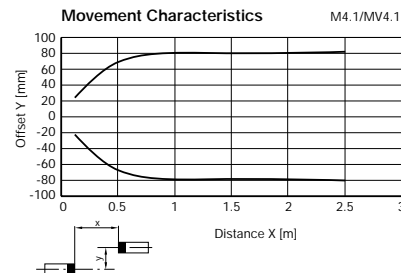
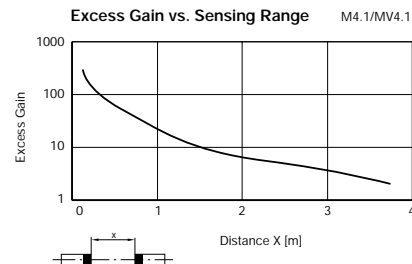

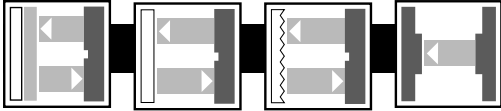

Series Specifications

ML4.1 Series Specifications		
LOAD CURRENT	200mA max.	
VOLTAGE DROP	≤1.2VDC	
SHORT CIRCUIT AND OVERLOAD PROTECTION	Yes	
REVERSE POLARITY PROTECTION	Yes	
VOLTAGE RIPPLE	10%	
LED(s)	Yes (2)	
CURRENT CONSUMPTION	≤25mA	
OPERATING MODE	Light on/dark on	
RESPONSE TIME	≤1.0ms	
SWITCHING FREQUENCY	500Hz	
ELECTROMAGNETIC COMPATIBILITY COMPLIANCE	NEMA ICS5-2000 See page 6	
PROTECTION (IEC)	IP65	
TEMPERATURE RANGE	WORKING	-4°F to +140°F
	STORAGE	-4°F to +167°F
HOUSING MATERIAL	ABS GV5	
LENS	Glass	
WEIGHT	0.5oz (per housing)	
APPROVALS	General Purpose	Yes
	General Purpose	Yes

Wiring Diagrams

DC



Quick Disconnect

Note: Wiring diagrams show quick disconnect pin numbers.

V31 Type

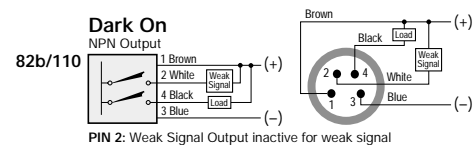
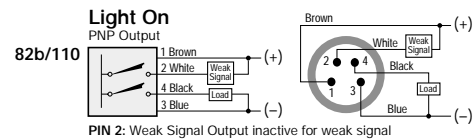
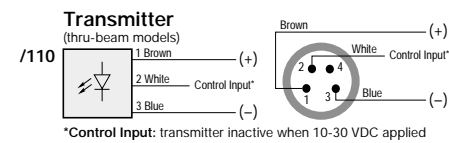
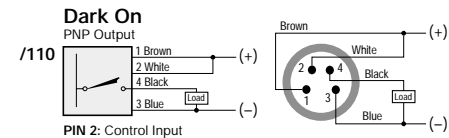
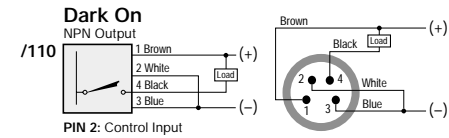
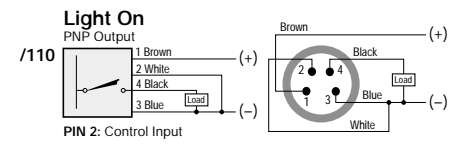
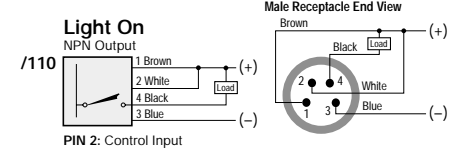

Photoelectric ML4.1 Series Sub-Miniature Style

Photoelectric Sensors

Dimensions (mm)

M4.1/MV4.1

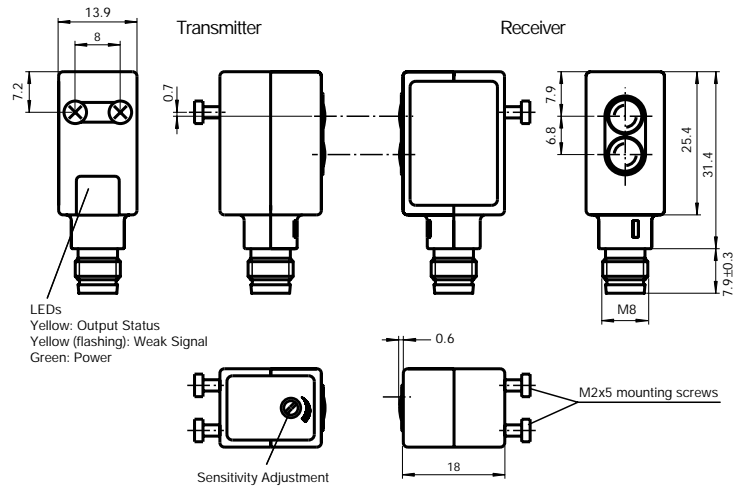

ML4.1-54

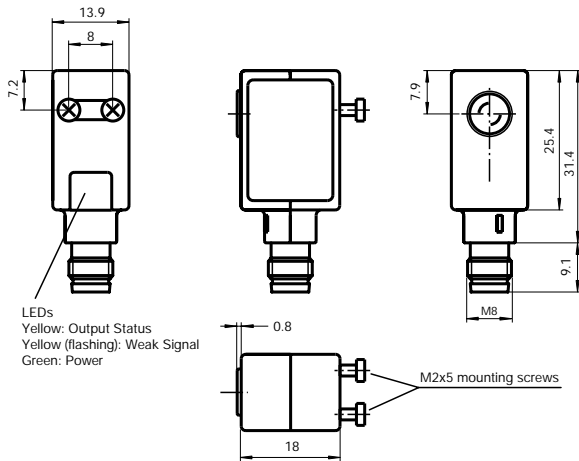

ML4.1-8

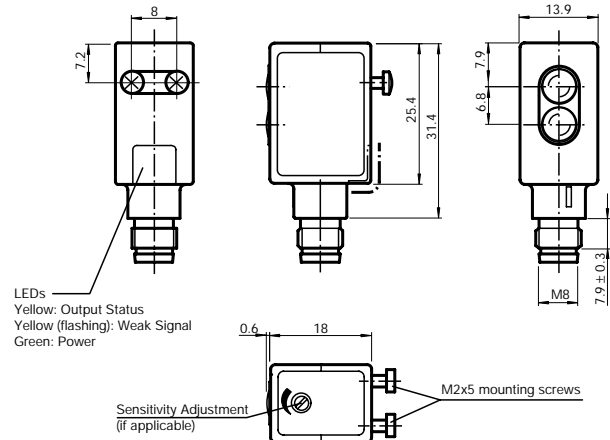

Accessories

(Dimensions in mm)

Mounting Collar Model OMH-4.1

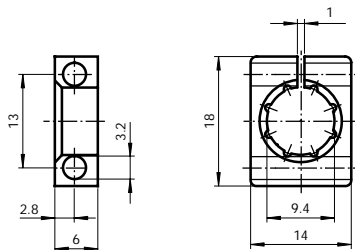

See pages
769-828 for
cordsets



See pages 829-840
additional accessories
for photoelectric sensors



ML7 Series Miniature Style Sensors

- Simple one button automatic programming
- Horizontal and vertical mounting
- IP67 housings



Diffused Mode

See page 350

Features:

- Visible red light source
- Vertical housing has output LED visible through lens

Sensing Range: 200mm

Outputs: NPN, PNP

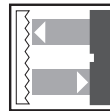

Retro-Reflective Mode

See pages 351-352

Features:

- Polarization filter detects shiny objects
- Vertical housing has output LED visible through lens

Sensing Ranges: 2.5m

Outputs: NPN, PNP



Thru-Beam Mode

See page 353

Features:

- Visible red light source
- Vertical housing has output LED visible through lens

Sensing Range: 3.5m

Outputs: NPN, PNP

See pages 354-358 for ML7 series specifications, wiring and dimensions.

Photoelectric Sensors



Diffused Mode

Specifications					
SENSING RANGE		20-200mm	20-200mm	20-200mm	20-200mm
SENSITIVITY ADJUSTMENT		Yes	Yes	Yes	Yes
DIRECTIONAL MOUNTING		Vertical	Vertical	Horizontal	Horizontal
MODEL NUMBER(S)		ML7-8-200/25/102/115	ML7-8-200/25/102/143	ML71-8-200/25/102/115	ML71-8-200/25/102/143
		ML7-8-200/25/103/115	ML7-8-200/25/103/143	ML71-8-200/25/103/115	ML71-8-200/25/103/143
		ML7-8-200/59/102/115	—	ML71-8-200/59/102/115	—
		ML7-8-200/59/103/115	—	—	—
OUTPUT: Transistor, Normally Open and Normally Closed	/102	1 NPN	1 NPN	1 NPN	1 NPN
	/103	1 PNP	1 PNP	1 PNP	1 PNP
SUPPLY VOLTAGE		10-30VDC	10-30VDC	10-30VDC	10-30VDC
CURRENT CONSUMPTION		≤20mA	≤20mA	≤20mA	≤20mA
OPERATING MODE	/25	Light on	Light on	Light on	Light on
	/59	Dark on	—	Dark on	—
LIGHT SPOT DIAMETER		≈15mm at a range of 200mm	≈15mm at a range of 200mm	≈15mm at a range of 200mm	≈15mm at a range of 200mm
WEIGHT		1.8oz	0.4oz	1.8oz	0.4oz
ELECTRICAL CONNECTION		2-meter cable, PVC covered 4-conductor, #26AWG	Quick disconnect type V31	2-meter cable, PVC covered 4-conductor, #26AWG	Quick disconnect type V31
ADDITIONAL DATA		See pages 354-358			

Sensing Characteristics

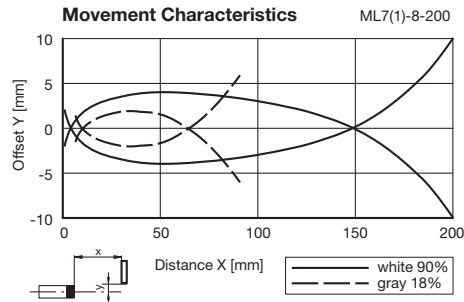
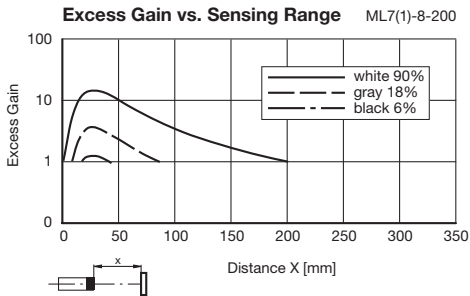

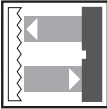

Retro-Reflective Mode

Photoelectric ML7 Series Miniature Style

Specifications		0-2.5m	0-2.5m	0-2.5m	0-2.5m
SENSING RANGE		0-2.5m	0-2.5m	0-2.5m	0-2.5m
SENSITIVITY ADJUSTMENT		Yes	Yes	Yes	Yes
DIRECTIONAL MOUNTING		Vertical	Vertical	Horizontal	Horizontal
REFLECTOR DISTANCE		30mm-2.5m	30mm-2.5m	30mm-2.5m	30mm-2.5m
POLARIZED FILTER		Yes	Yes	Yes	Yes
MODEL NUMBER(S)	ML7-55/25/102/115	—	—	—	—
	—	—	—	—	—
	ML7-55/59/102/115	ML7-55/59/102/143	ML71-55/59/102/115	ML71-55/59/102/143	
	ML7-55/59/103/115	ML7-55/59/103/143	ML71-55/59/103/115	ML71-55/59/103/143	
OUTPUT: Transistor, Normally Open and Normally Closed	/102	1 NPN	1 NPN	1 NPN	1 NPN
	/103	1 PNP	1 PNP	1 PNP	1 PNP
SUPPLY VOLTAGE		10-30VDC	10-30VDC	10-30VDC	10-30VDC
CURRENT CONSUMPTION		≤20mA	≤20mA	≤20mA	≤20mA
OPERATING MODE	/25	Light on	—	—	—
	/59	Dark on	Dark on	Dark on	Dark on
LIGHT SPOT DIAMETER		≈180mm at a range of 2.5m	≈180mm at a range of 2.5m	≈180mm at a range of 2.5m	≈180mm at a range of 2.5m
WEIGHT		1.8oz	0.4oz	1.8oz	0.4oz
ELECTRICAL CONNECTION		2-meter cable, PVC covered 4-conductor, #26AWG	Quick disconnect type V31	2-meter cable, PVC covered 4-conductor, #26AWG	Quick disconnect type V31
ADDITIONAL DATA		See pages 354-358			



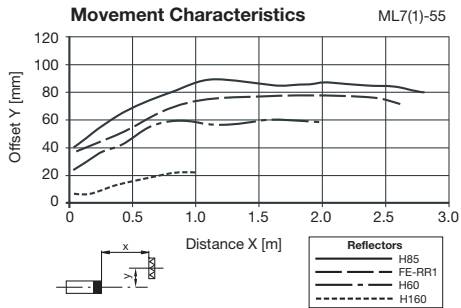
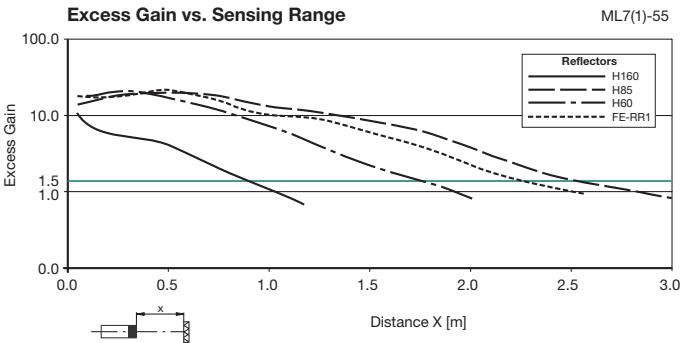

Sensing Characteristics



Photoelectric Sensors



Retro-Reflective Mode

Specifications		0-2.5m	0-2.5m	0-2.5m	0-2.5m
SENSING RANGE		0-2.5m	0-2.5m	0-2.5m	0-2.5m
SENSITIVITY ADJUSTMENT		Yes	Yes	Yes	Yes
DIRECTIONAL MOUNTING		Vertical	Vertical	Horizontal	Horizontal
REFLECTOR DISTANCE		20mm-2.5m	20mm-2.5m	20mm-2.5m	20mm-2.5m
POLARIZED FILTER		No	No	No	No
MODEL NUMBER(S)	ML7-6/25/102/115		—	—	—
	—	—	—	—	—
	ML7-6/59/102/115	ML7-6/59/102/143	ML71-6/59/102/115	ML71-6/59/102/143	
	ML7-6/59/103/115	ML7-6/59/103/143	ML71-6/59/103/115	ML71-6/59/103/143	
OUTPUT: Transistor, Normally Open and Normally Closed	/102	1 NPN	1 NPN	1 NPN	1 NPN
	/103	1 PNP	1 PNP	1 PNP	1 PNP
SUPPLY VOLTAGE		10-30VDC	10-30VDC	10-30VDC	10-30VDC
CURRENT CONSUMPTION		≤20mA	≤20mA	≤20mA	≤20mA
OPERATING MODE	/25	Light on	—	—	—
	/59	Dark on	Dark on	Dark on	Dark on
LIGHT SPOT DIAMETER		≈180mm at a range of 2.5m	≈180mm at a range of 2.5m	≈180mm at a range of 2.5m	≈180mm at a range of 2.5m
WEIGHT		1.8oz	0.4oz	1.8oz	0.4oz
ELECTRICAL CONNECTION		 2-meter cable, PVC covered 4-conductor, #26AWG	 Quick disconnect type V31	 2-meter cable, PVC covered 4-conductor, #26AWG	 Quick disconnect type V31
ADDITIONAL DATA	See pages 354-358				

Sensing Characteristics

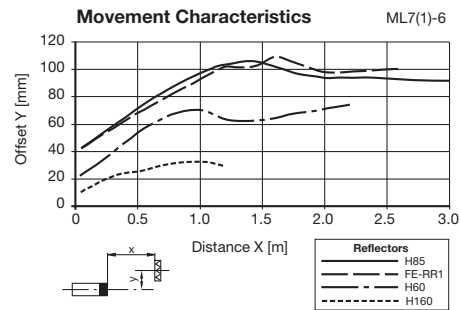
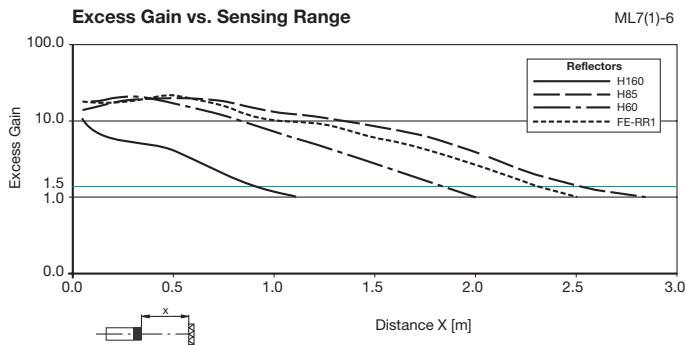



Thru-Beam Mode

Specifications		0-3.5m	0-3.5m	0-3.5m	0-3.5m
SENSING RANGE		0-3.5m	0-3.5m	0-3.5m	0-3.5m
SENSITIVITY ADJUSTMENT		Yes	Yes	Yes	Yes
DIRECTIONAL MOUNTING		Vertical	Vertical	Horizontal	Horizontal
MODEL NUMBER(S)	Transmitter	M7/76a/115	M7/76a/143	M71/76a/115	M71/76a/143
	Receiver	MV7/59/102/115	MV7/59/102/126b/143	MV71/59/102/115	MV71/59/102/126b/143
		MV7/59/82b/103/115	MV7/59/82b/103/143	MV71/59/82b/103/115	MV71/59/82b/103/143
OUTPUT: Transistor, Normally Open and Normally Closed	/102	1 NPN	1 NPN	1 NPN	1 NPN
	/103	1 PNP	1 PNP	1 PNP	1 PNP
SUPPLY VOLTAGE		10-30VDC	10-30VDC	10-30VDC	10-30VDC
CURRENT CONSUMPTION		≤17mA transmitter, ≤15mA receiver	≤17mA transmitter, ≤15mA receiver	≤17mA transmitter, ≤15mA receiver	≤17mA transmitter, ≤15mA receiver
OPERATING MODE		Dark on	Dark on	Dark on	Dark on
LIGHT SPOT DIAMETER		≈240mm at a range of 3.5m	≈240mm at a range of 3.5m	≈240mm at a range of 3.5m	≈240mm at a range of 3.5m
WEIGHT		1.8oz (per housing)	0.4oz (per housing)	1.8oz (per housing)	0.4oz (per housing)
ELECTRICAL CONNECTION		2-meter cable, PVC covered 4-conductor, #26AWG	Quick disconnect type V31	2-meter cable, PVC covered 4-conductor, #26AWG	Quick disconnect type V31
ADDITIONAL DATA		See pages 354-358			

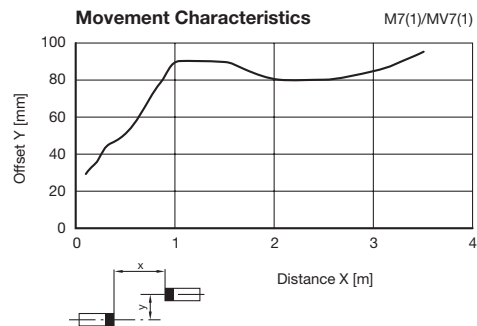
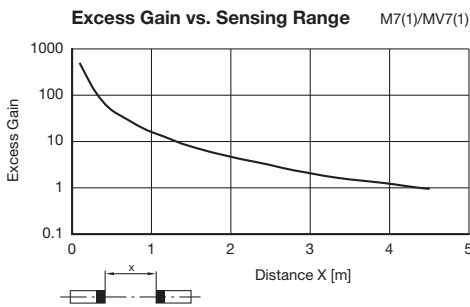

Sensing Characteristics



Photoelectric Sensors



Series Specifications

ML7 Series Specifications	
LOAD CURRENT	100mA max.
VOLTAGE DROP	≤1.5VDC
SHORT CIRCUIT AND OVERLOAD PROTECTION	Yes
REVERSE POLARITY PROTECTION	Yes
VOLTAGE RIPPLE	10%
LEDs	Yes (2)
RESPONSE TIME	0.5ms
SWITCHING FREQUENCY	1kHz
ELECTROMAGNETIC COMPATIBILITY COMPLIANCE	NEMA ICS5-2000 See page 6
PROTECTION (IEC)	IP67
LIGHT BEAM ANGLE	≈4.5°
LIGHT SOURCE	Visible red LED
AMBIENT LIGHT RESISTANCE	≤40,000 lux
TEMPERATURE RANGE	<i>WORKING</i> -4°F to +140°F <i>STORAGE</i> -40°F to +167°F
HOUSING MATERIAL	Polycarbonate
LENS	PMMA
APPROVALS	<div style="display: flex; align-items: center;"> <div style="margin-right: 10px;">  LISTED </div> <div style="margin-right: 10px;"> General Purpose </div> <div style="margin-right: 10px;"> Yes </div> </div> <div style="margin-top: 10px;"> <div style="display: flex; align-items: center;"> <div style="margin-right: 10px;">  </div> <div style="margin-right: 10px;">  CERTIFIED </div> <div style="margin-right: 10px;"> General Purpose </div> <div> Yes </div> </div> </div>

Wiring Diagrams

DC



Cable Connection

Light On (/25)

Dark On (/59)

NPN Output

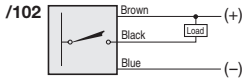

Light On (/25)

Dark On (/59)

PNP Output

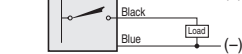

Dark On

NPN Output

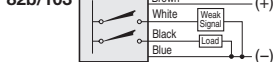

PIN 2: Weak Signal Output inactive for weak signal

Transmitter

(thru-beam models)



*Control Input: transmitter inactive when 10-30 VDC applied



Quick Disconnect

Note: Wiring diagrams show quick disconnect pin numbers.

V31 Type

Light On (/25)

Dark On (/59)

NPN Output



Male Receptacle End View

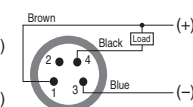

Light On (/25)

Dark On (/59)

PNP Output

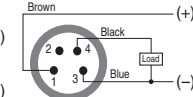

Dark On

NPN Output

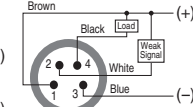
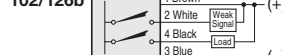

PIN 2: Weak Signal Output inactive for weak signal

Dark On

NPN Output

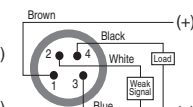
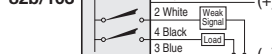

PIN 2: Weak Signal Output inactive for weak signal

Transmitter

(thru-beam models)

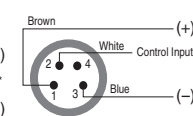

*Control Input: transmitter inactive when 10-30 VDC applied

ML7 Programming

1. With the sensor connected to the specified supply voltage, aim the sensor's light beam at the target for diffused mode, at the reflector for retro-reflective mode, or align the transmitter and receiver for thru-beam mode.
2. Press the teach button once. The green LED will turn off and on again to acknowledge this step.
3. Press and hold the teach button until the green and yellow LEDs blink simultaneously (2 Hz frequency). The green and yellow LEDs will then blink alternately (2 Hz frequency) to indicate an internal set-up procedure.

If the teach is successful, both the green and yellow LEDs should be on continuously. The green LED indicates power is supplied to the sensor, and the yellow LED indicates the output status.

If the teach is not successful, then both the green and yellow LEDs blink alternately at a faster rate (4 Hz frequency) for about 5 seconds and the sensor will return to its maximum sensitivity default setting. In this case, steps 1 through 3 should be repeated.

The default setting for this series is maximum sensitivity. If resetting the sensitivity to default is desired, repeat steps 1 through 3 but with no target, reflector, or thru-beam alignment.

Photoelectric Sensors

Dimensions (mm)

Photoelectric ML7 Series Miniature Style

ML7...

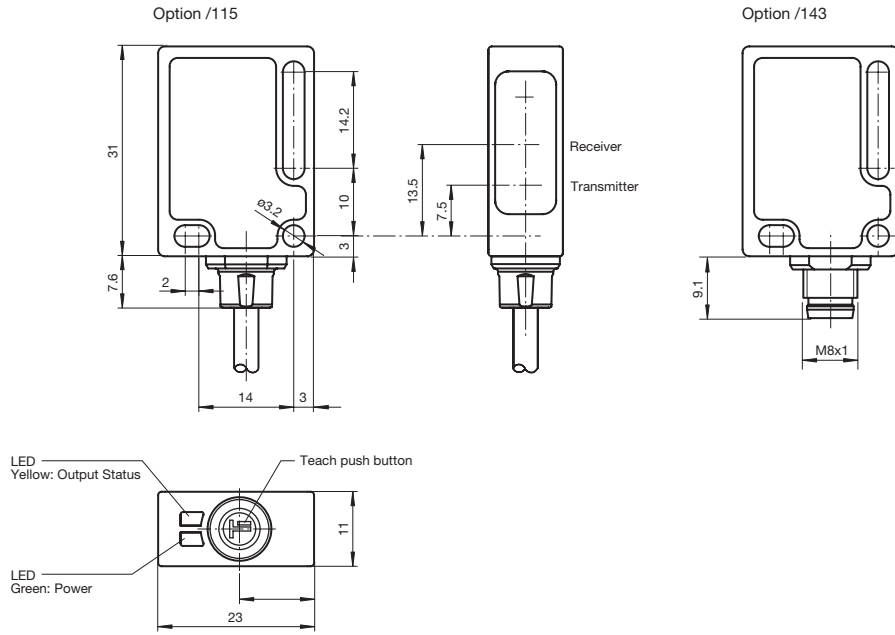

ML71...

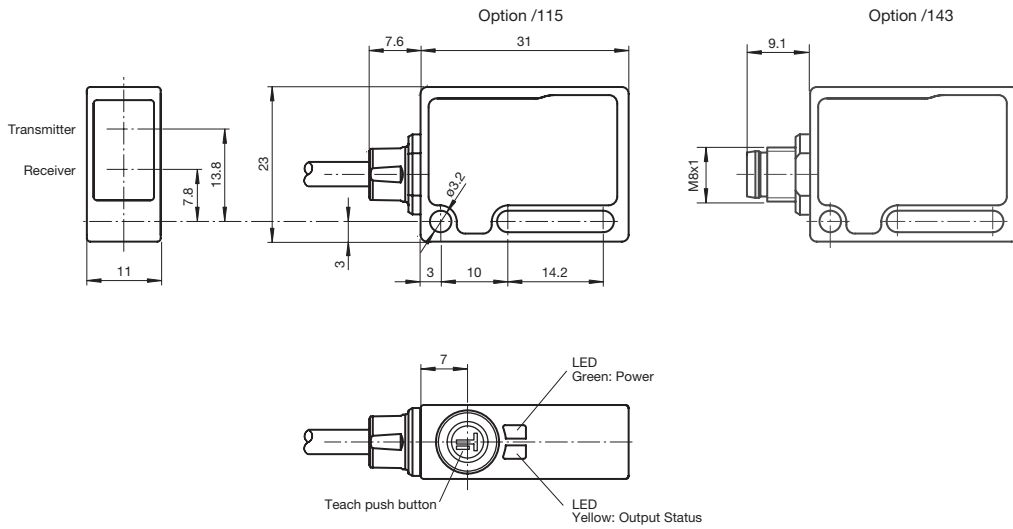

Dimensions (mm)

M7/MV7...

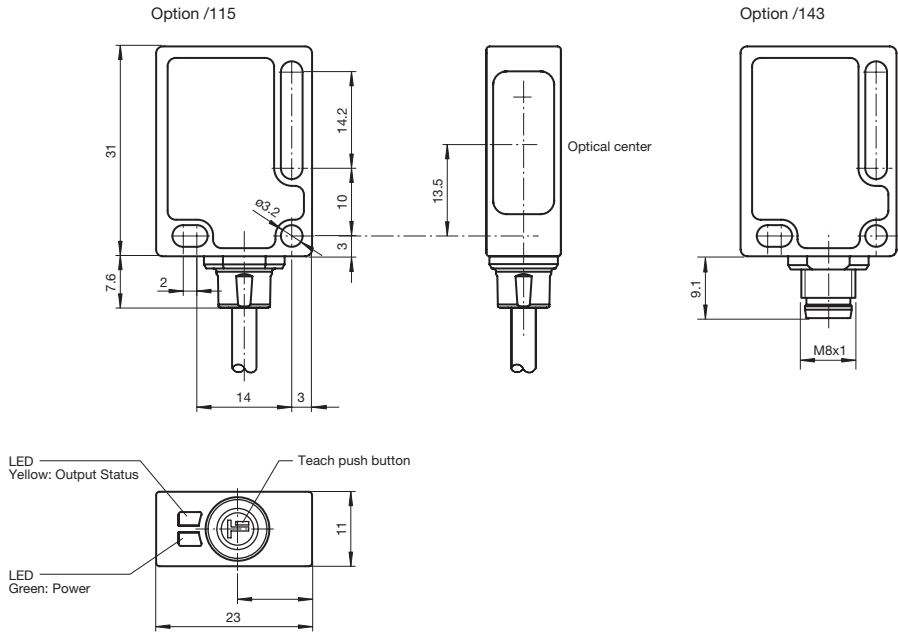

M71/MV71...

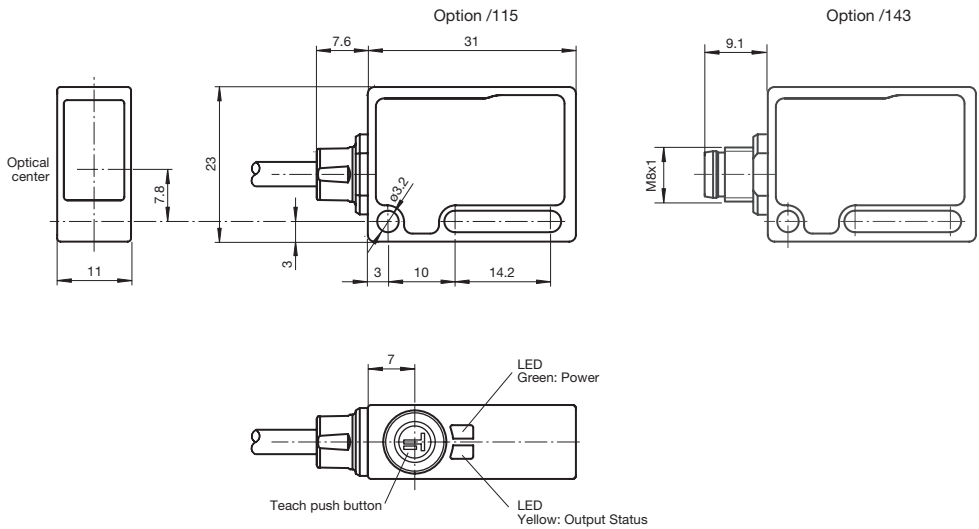

Photoelectric ML7 Series Miniature Style

Photoelectric Sensors

Photoelectric ML7 Series Miniature Style

Accessories

(Dimensions in mm)

Mounting Kit Model OMH-ML7-01-KIT

Hardware kit for ML7 vertical sensors. Includes bracket, brace, (2) screws, (2) nuts, and (4) washers.

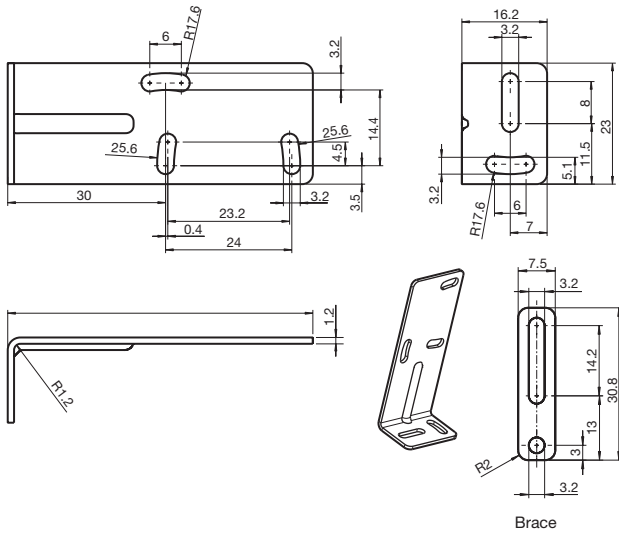

Mounting Kit Model OMH-ML7-02-KIT

Hardware kit for ML7 horizontal sensors. Includes bracket, brace, (2) screws, (2) nuts, and (4) washers.

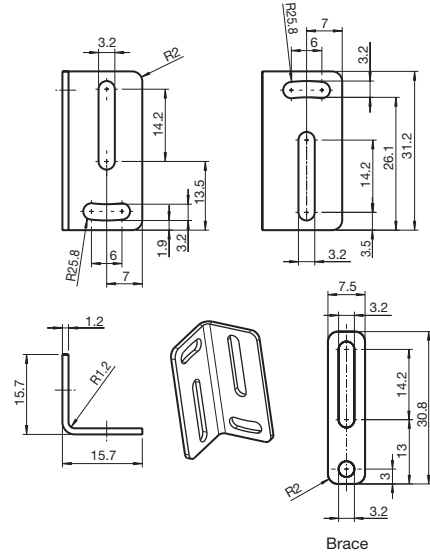

See pages
767-812 for
cordsets



See pages 825-836
additional accessories
for photoelectric sensors

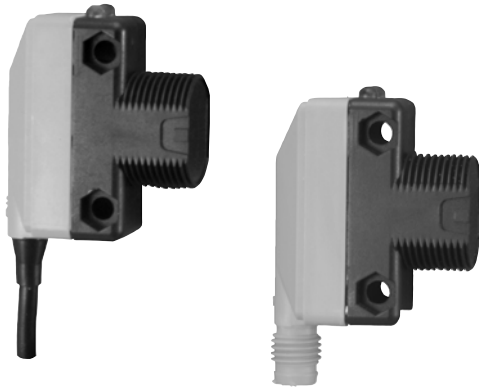

ML17 Series Tru-View™ Style Sensors

- Cost-effective
- Compact footprint
- Versatile mounting



Diffused Mode

See page 2

Features:

- Sensitivity adjustment for sensing range
- 360° high-visibility LEDs

Sensing Range: 450mm

Outputs: NPN, PNP

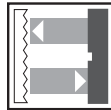

Retro-Reflective Mode

See page 2

Features:

- Polarized and long-range nonpolarized models
- 360° high-visibility LEDs



Sensing Range: 3.5m, 6.5m

Outputs: NPN, PNP

Photoelectric Sensors







Diffused Mode



Specifications			
SENSING RANGE	10-450mm	10-450mm	10-450mm
SENSITIVITY ADJUSTMENT	Yes (single-turn potentiometer)	Yes (single-turn potentiometer)	Yes (single-turn potentiometer)
REFERENCE TARGET	100 x 100mm white test card	100 x 100mm white test card	100 x 100mm white test card
MODEL NUMBER(S)	ML17-8-450/115/120	ML17-8-450/115b/120	ML17-8-450/120/143
	ML17-8-450/115/127	ML17-8-450/115b/127	ML17-8-450/127/143
OUTPUT:	/120	2 PNP	2 PNP
	/127	2 NPN	2 NPN
SUPPLY VOLTAGE	10-30VDC	10-30VDC	10-30VDC
LIGHT SOURCE	Infrared LED 950nm	Infrared LED 950nm	Infrared LED 950nm
WEIGHT	1.4oz	0.8oz	0.3oz
ELECTRICAL CONNECTION	 2-meter cable, PVC covered, 4-conductor, #26AWG	 150mm pigtail, PVC covered, quick disconnect type V1	 Quick disconnect type V31, integral
ADDITIONAL DATA	See pages 3-4		



Retro-Reflective Mode

Specifications				
SENSING RANGE	0-3.5m	0-3.5m	0-3.5m	0-6.5m
SENSITIVITY ADJUSTMENT	Yes (single-turn potentiometer)	Yes (single-turn potentiometer)	Yes (single-turn potentiometer)	Yes (single-turn potentiometer)
REFERENCE TARGET	FE-RR1 reflector	FE-RR1 reflector	FE-RR1 reflector	FE-RR1 reflector
REFLECTOR DISTANCE	50mm-3.5m	50mm-3.5m	50mm-3.5m	50mm-6.5m
POLARIZATION FILTER	Yes	Yes	Yes	No
MODEL NUMBER(S)	ML17-54/115/120	ML17-54/115b/120	ML17-54/120/143	ML17-6/115/120
	ML17-54/115/127	ML17-54/115b/127	ML17-54/127/143	ML17-6/115/127
OUTPUT:	/120	2 PNP	2 PNP	2 PNP
	/127	2 NPN	2 NPN	2 NPN
SUPPLY VOLTAGE	10-30VDC	10-30VDC	10-30VDC	10-30VDC
LIGHT SOURCE	Visible red LED 626nm	Visible red LED 626nm	Visible red LED 626nm	Visible red LED 626nm
WEIGHT	1.4oz	0.8oz	0.3oz	1.4oz
ELECTRICAL CONNECTION	 2-meter cable, PVC covered, 4-conductor, #26AWG	 150mm pigtail, PVC covered, quick disconnect type V1	 Quick disconnect type V31, integral	 2-meter cable, PVC covered, 4-conductor, #26AWG
ADDITIONAL DATA	See pages 3-4			

ML17 Series Specifications

LOAD CURRENT	100mA max. per output
LEAKAGE CURRENT	≤10μA per output
VOLTAGE DROP	≤2VDC
SHORT CIRCUIT AND OVERLOAD PROTECTION	Yes
REVERSE POLARITY PROTECTION	Yes
VOLTAGE RIPPLE	±10%
LED(s)	Yes (2)
OPERATING MODE	Light on/dark on
CURRENT CONSUMPTION	≤25mA
RESPONSE TIME	≤1.0ms
READINESS DELAY	≤200ms
SWITCHING FREQUENCY	500Hz
PROTECTION (IEC)	IP67
AMBIENT LIGHT RESISTANCE	≤10,000 lux
TEMPERATURE RANGE	<i>WORKING</i> -4°F to +131°F
	<i>STORAGE</i> -4°F to +167°F
HOUSING MATERIAL	ABS
LENS	Acrylic
APPROVALS	Yes
  General Purpose	

Wiring Diagrams

DC



Cable Connection

Light On/Dark On

PNP Outputs

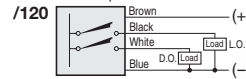

Light On/Dark On

NPN Outputs

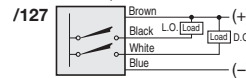

Quick Disconnect

Note: Wiring Diagrams show quick disconnect pin numbers.

V1 Type

Light On/Dark On

PNP Outputs

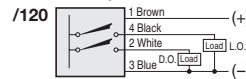

Male Receptacle End View

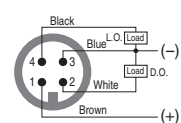

Light On/Dark On

NPN Outputs

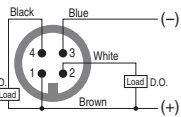
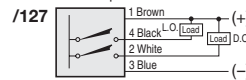

V31 Type

Light On/Dark On

PNP Outputs

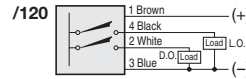

Male Receptacle End View

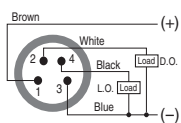

Light On/Dark On

NPN Outputs

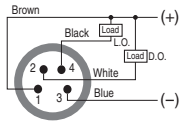
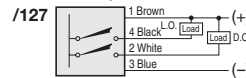

Photoelectric Sensors

Dimensions (mm)

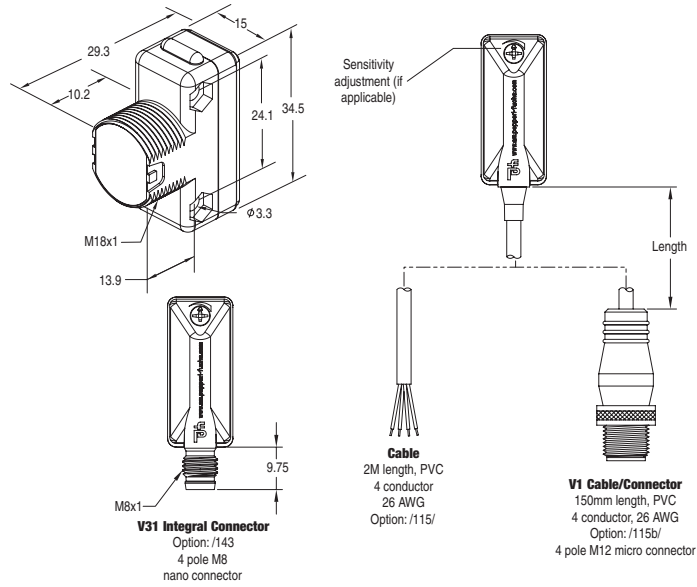

Accessories

Snout-mount Mounting Bracket Model OMH-ML17 for ML17 Series sensors

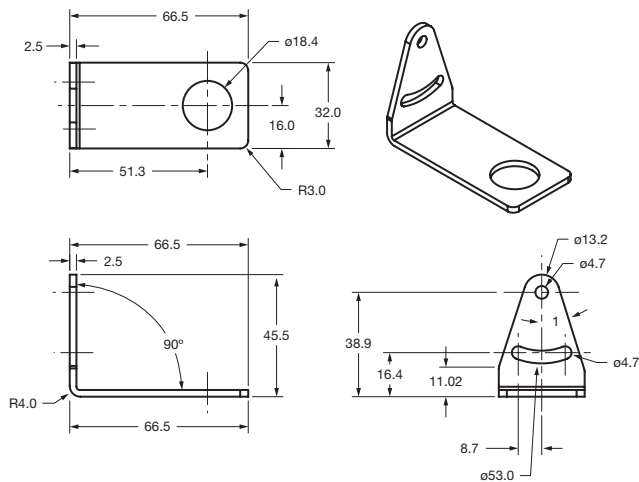

Side-mount Mounting Bracket Model OMH-ML17-1 for ML17 Series sensors

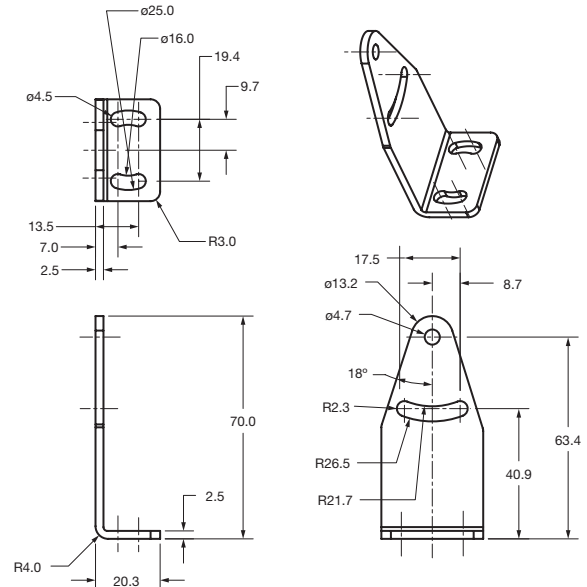



MLV11 Series Power Touch Style Sensors

- Adjustable connector position
- Input function for added control
- Thru-hole or dovetail mounting



Diffused Mode with Background Suppression

See page 344

Features:

- Sharp sensing range cut-off
- Visible red LED light source

Sensing Range: 150mm

Outputs: NPN, PNP

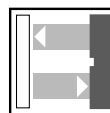

Diffused Mode

See pages 345-347

Features:

- Laser light source version has 0.1mm light spot diameter
- "Enhanced" sensor parameters programmable via optical interface

Sensing Ranges: 150mm, 300mm, 500mm

Outputs: NPN, PNP, AS-Interface

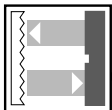

Retro-Reflective Mode

See pages 348-349

Features:

- Laser light source version has 50mm light spot diameter at 15m range
- "Enhanced" sensor parameters programmable via optical interface

Sensing Ranges: 6m, 15m

Outputs: NPN, PNP, AS-Interface

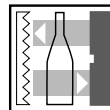

Retro-Reflective Mode for Clear Object Detection

See page 350

Features:

- Detects clear glass, plastics, and transparent films
- "Enhanced" sensor parameters programmable via optical interface

Sensing Range: 3m

Outputs: NPN, PNP, AS-Interface

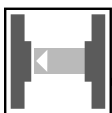

Thru-Beam Mode

See page 351

Features:

- Membrane push-button sensitivity adjustment
- "Enhanced" sensor parameters programmable via optical interface

Sensing Range: 15m

Outputs: NPN, PNP

See pages 352-358 for MLV11 series specifications, programming, wiring and dimensions.

Photoelectric Sensors

Photoelectric MLV11 Series Power Touch Style



Diffused Mode with Background Suppression

Specifications	
SENSING RANGE	0-150mm
SENSITIVITY ADJUSTMENT	Yes (20-150mm)
REFERENCE TARGET	100 x 100mm white test card
MODEL NUMBER(S)	MLV11-8-H-150/47/65a/76a/112
	MLV11-8-H-150/48/65a/76b/112
OUTPUT: Transistor, Normally Open and Normally Closed	/47 2 PNP
	/48 2 NPN
LOAD CURRENT	100mA max.
LEAKAGE CURRENT	≤10μA
VOLTAGE DROP	≤2.5VDC
SHORT CIRCUIT AND OVERLOAD PROTECTION	Yes
SUPPLY VOLTAGE	10-30VDC
VOLTAGE RIPPLE	10%
CURRENT CONSUMPTION	≤25mA
RESPONSE TIME	≤0.5ms
READINESS DELAY	≤80ms
SWITCHING FREQUENCY	1kHz
PROTECTION (IEC)	IP67
LIGHT SPOT DIAMETER	4mm at a range of 80mm
LIGHT SOURCE	Visible red LED 670nm
TEMPERATURE RANGE	<i>WORKING</i> -13°F to +158°F
	<i>STORAGE</i> -40°F to +158°F
HOUSING MATERIAL	ABS
<i>LENS</i>	Scratch-resistant coated plastic
<i>CONNECTOR/DOVETAIL</i>	AISI
WEIGHT	1.4oz
ELECTRICAL CONNECTION	 Quick disconnect type V15
ADDITIONAL DATA	<i>See pages 352-358</i>



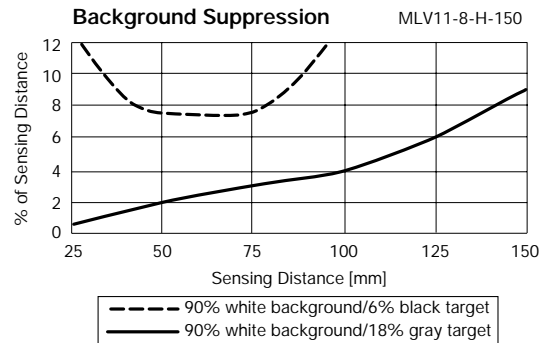
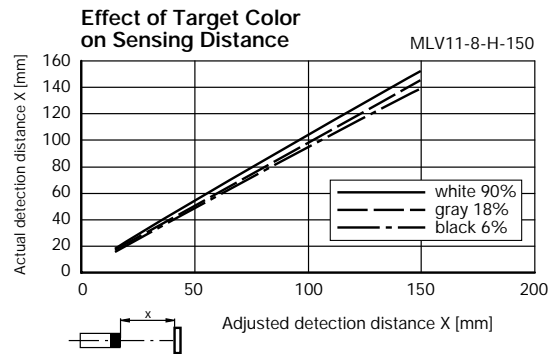

Sensing Characteristics

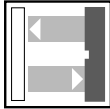



Diffused Mode

Specifications			
SENSING RANGE		0-500mm	0-500mm
SENSITIVITY ADJUSTMENT		Yes (50-500mm)	Yes (50-500mm)
REFERENCE TARGET		100 x 100mm white test card	100 x 100mm white test card
MODEL NUMBER(S)		MLV11-8-500/47/112	—
		MLV11-8-500/48/112	—
		—	MLV11-8-500-AS-I/112
OUTPUT:	/47	2 PNP	—
	/48	2 NPN	—
	-AS-I	—	AS-Interface
LOAD CURRENT		200mA max.	—
LEAKAGE CURRENT		≤10μA	—
VOLTAGE DROP		≤2.5VDC	—
SHORT CIRCUIT AND OVERLOAD PROTECTION		Yes	Yes
SUPPLY VOLTAGE		10-30VDC	from AS-Interface
VOLTAGE RIPPLE		10%	—
CURRENT CONSUMPTION		≤25mA	—
OPERATING CURRENT		—	≤35mA
RESPONSE TIME		Programmable	Programmable
READINESS DELAY		≤80ms	≤80ms
SWITCHING FREQUENCY		Programmable	Programmable
PROTECTION (IEC)		IP68	IP68
LIGHT SPOT DIAMETER		25mm at a range of 500mm	25mm at a range of 500mm
LIGHT SOURCE		Visible red LED 660nm	Visible red LED 660nm
TEMPERATURE RANGE	WORKING	-13°F to +158°F	-13°F to +158°F
	STORAGE	-40°F to +158°F	-40°F to +158°F
HOUSING MATERIAL		Crastin	Crastin
LENS		Scratch-resistant coated plastic	Scratch-resistant coated plastic
CONNECTOR/DOVETAIL		ASi	ASi
WEIGHT		2.1oz	2.1oz
ELECTRICAL CONNECTION		 Quick disconnect type V15	 Quick disconnect type V15
ADDITIONAL DATA		See pages 352-358	

Sensing Characteristics

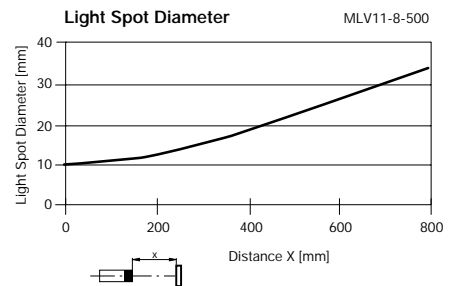
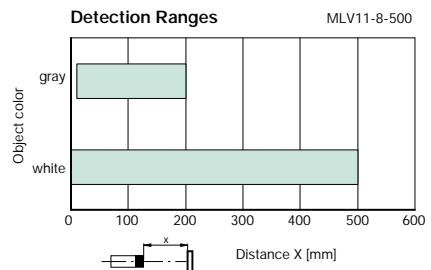
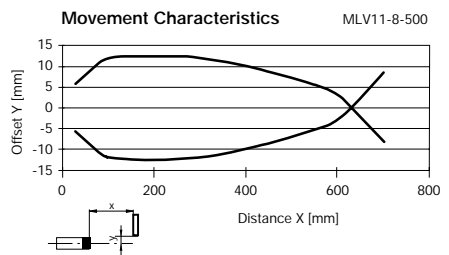
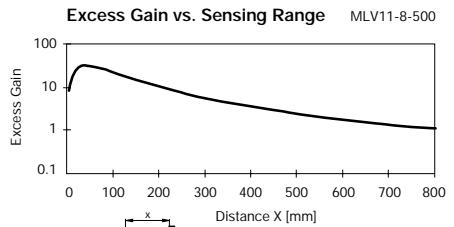

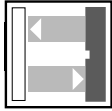

Photoelectric Sensors



Diffused Mode

Photoelectric MLV11 Series Power Touch Style

Specifications	Laser	
	0-150mm	0-300mm
SENSING RANGE	0-150mm	0-300mm
SENSITIVITY ADJUSTMENT	Yes (50-150mm)	Yes (50-300mm)
REFERENCE TARGET	10 x 10mm white test card	100 x 100mm white test card
MODEL NUMBER(S)	MLV11-8-LAS-150/47/112	MLV11-8-LAS-300/47/112
	MLV11-8-LAS-150/48/112	MLV11-8-LAS-300/48/112
OUTPUT: Transistor, Normally Open and Normally Closed (programmable)		
/47	2 PNP	2 PNP
/48	2 NPN	2 NPN
LOAD CURRENT	200mA max.	200mA max.
LEAKAGE CURRENT	≤10µA	≤10µA
VOLTAGE DROP	≤2.5VDC	≤2.5VDC
SHORT CIRCUIT AND OVERLOAD PROTECTION	Yes	Yes
SUPPLY VOLTAGE	10-30VDC	10-30VDC
VOLTAGE RIPPLE	10%	10%
CURRENT CONSUMPTION	≤25mA	≤25mA
RESPONSE TIME	Programmable	Programmable
READINESS DELAY	≤50ms	≤50ms
SWITCHING FREQUENCY	Programmable	Programmable
PROTECTION (IEC)	IP68	IP68
LIGHT SPOT DIAMETER	0.1mm at a range of 60mm	0.1mm at a range of 60mm
LIGHT SOURCE	Visible red laser 670nm Class 2	Visible red laser 670nm Class 2
TEMPERATURE RANGE	WORKING +14°F to +104°F	+14°F to +104°F
	STORAGE -40°F to +158°F	-40°F to +158°F
HOUSING MATERIAL	Crastin	Crastin
LENS	Scratch-resistant coated plastic	Scratch-resistant coated plastic
CONNECTOR/DOVETAIL	AISI	AISI
WEIGHT	2.1oz	2.1oz
ELECTRICAL CONNECTION	 Quick disconnect type V15	 Quick disconnect type V15
ADDITIONAL DATA	<i>See pages 352-358</i>	



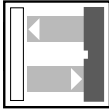

Diffused Mode

Sensing Characteristics

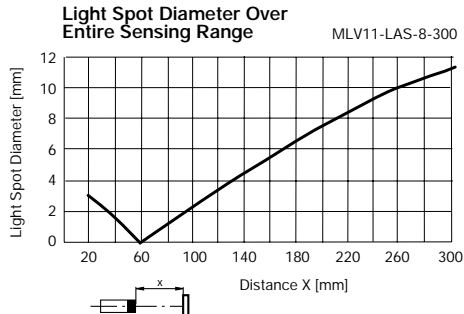
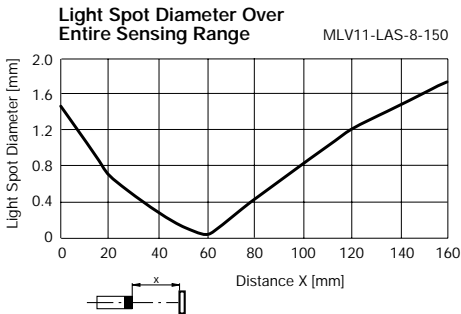
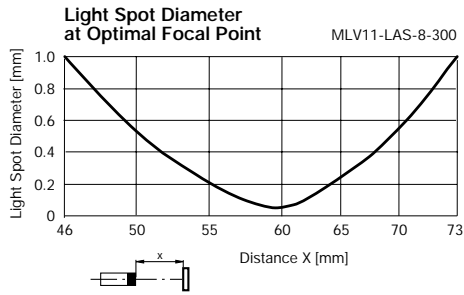
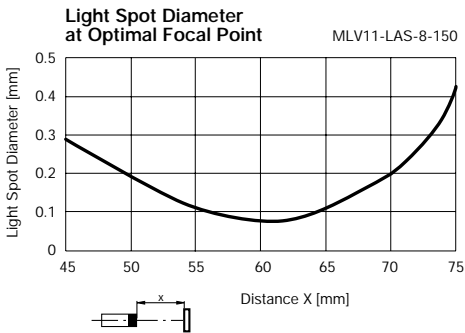
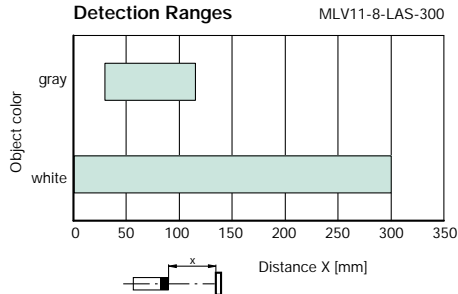
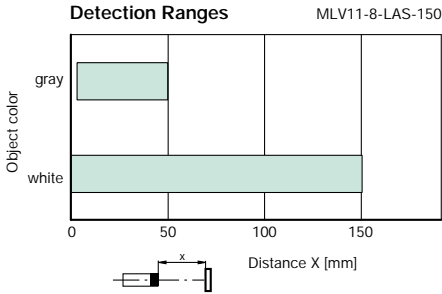



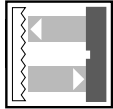

Photoelectric Sensors



Retro-Reflective Mode

Photoelectric MLV11 Series Power Touch Style

Specifications			Laser
SENSING RANGE	0-6m	0-6m	0-15m
SENSITIVITY ADJUSTMENT	Yes (0-6m)	Yes (0-6m)	Yes (0-15m)
REFERENCE TARGET	H85 reflector	H85 reflector	H60 reflector
REFLECTOR DISTANCE	600mm-6m	600mm-6m	300mm-15m
POLARIZED FILTER	Yes	Yes	Yes
MODEL NUMBER(S)	MLV11-54/47/112	—	MLV11-54-LAS/47/112
	MLV11-54/48/112	—	MLV11-54-LAS/48/112
	—	MLV11-54-AS-I/112	—
OUTPUT:			
/47	2 PNP	—	2 PNP
/48	2 NPN	—	2 NPN
-AS-I	—	AS-Interface	—
LOAD CURRENT	200mA max.	—	200mA max.
LEAKAGE CURRENT	≤10μA	—	≤10μA
VOLTAGE DROP	≤2.5VDC	—	≤2.5VDC
SHORT CIRCUIT AND OVERLOAD PROTECTION	Yes	Yes	Yes
SUPPLY VOLTAGE	10-30VDC	from AS-Interface	10-30VDC
VOLTAGE RIPPLE	10%	—	10%
CURRENT CONSUMPTION	≤25mA	—	≤25mA
OPERATING CURRENT	—	≤35mA	—
RESPONSE TIME	Programmable	Programmable	Programmable
READINESS DELAY	≤80ms	≤80ms	≤50ms
SWITCHING FREQUENCY	Programmable	Programmable	Programmable
PROTECTION (IEC)	IP68	IP68	IP68
LIGHT SPOT DIAMETER	200mm at a range of 6m	200mm at a range of 6m	50mm at a range of 15m
LIGHT SOURCE	Visible red LED 660nm	Visible red LED 660nm	Visible red laser 670nm Class 2
TEMPERATURE RANGE			
WORKING	-13°F to +158°F	-13°F to +158°F	+14°F to +104°F
STORAGE	-40°F to +158°F	-40°F to +158°F	-40°F to +158°F
HOUSING MATERIAL	Crastin	Crastin	Crastin
LENS	Scratch-resistant coated plastic	Scratch-resistant coated plastic	Scratch-resistant coated plastic
CONNECTOR/DOVETAIL	ASi	ASi	ASi
WEIGHT	2.1oz	2.1oz	2.1oz
ELECTRICAL CONNECTION	 Quick disconnect type V15	 Quick disconnect type V15	 Quick disconnect type V15
ADDITIONAL DATA	<i>See pages 352-358</i>		

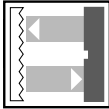

Retro-Reflective Mode

Sensing Characteristics

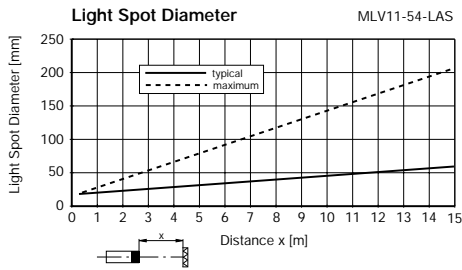
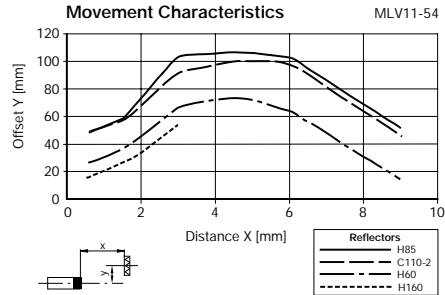
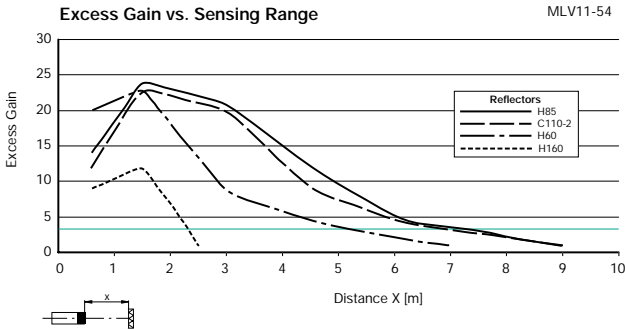

Photoelectric MLV11 Series Power Touch Style

Photoelectric Sensors

Photoelectric MLV11 Series Power Touch Style



Retro-Reflective Mode for Clear Object Detection



Specifications		100mm-3m	100mm-3m
SENSING RANGE		100mm-3m	100mm-3m
SENSITIVITY ADJUSTMENT		Yes (100mm-3m)	Yes (100mm-3m)
REFERENCE TARGET		H60 reflector	H60 reflector
REFLECTOR DISTANCE		600mm-3m	600mm-3m
POLARIZED FILTER		Yes	Yes
MODEL NUMBER(S)	MLV11-54-G/47/112	—	—
	MLV11-54-G/48/112	—	—
	—	—	MLV11-54-G-AS-I/112
OUTPUT:	/47	2 PNP	—
	/48	2 NPN	—
	-AS-I	—	AS-Interface
LOAD CURRENT		200mA max.	—
LEAKAGE CURRENT		≤10μA	—
VOLTAGE DROP		≤2.5VDC	—
SHORT CIRCUIT AND OVERLOAD PROTECTION		Yes	Yes
SUPPLY VOLTAGE		10-30VDC	from AS-Interface
VOLTAGE RIPPLE		10%	—
CURRENT CONSUMPTION		≤25mA	—
OPERATING CURRENT		—	≤35mA
RESPONSE TIME		Programmable	Programmable
READINESS DELAY		≤80ms	≤80ms
SWITCHING FREQUENCY		Programmable	Programmable
PROTECTION (IEC)		IP68	IP68
LIGHT SPOT DIAMETER		100mm at a range of 3m	100mm at a range of 3m
LIGHT SOURCE		Visible red LED 660nm	Visible red LED 660nm
TEMPERATURE RANGE	WORKING	-13°F to +158°F	-13°F to +158°F
	STORAGE	-40°F to +158°F	-40°F to +158°F
HOUSING MATERIAL		Crastin	Crastin
LENS		Scratch-resistant coated plastic	Scratch-resistant coated plastic
CONNECTOR/DOVETAIL		AlSi	AlSi
WEIGHT		2.1oz	2.1oz
ELECTRICAL CONNECTION		Quick disconnect type V15	Quick disconnect type V15
ADDITIONAL DATA		See pages 352-358	

Sensing Characteristics

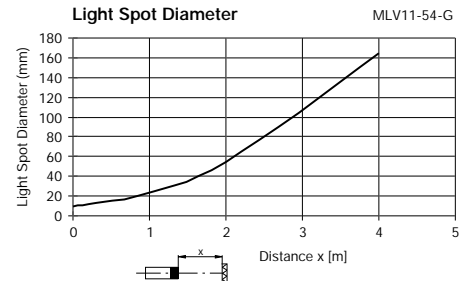
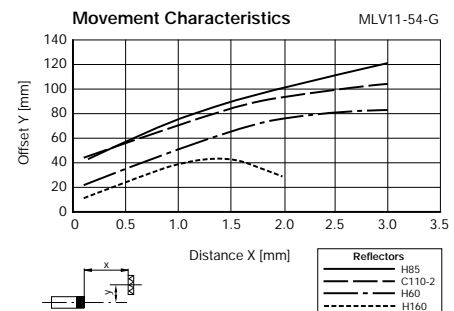
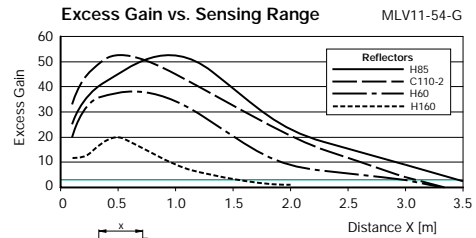

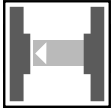

Thru-Beam Mode

Specifications	
SENSING RANGE	0-15m
SENSITIVITY ADJUSTMENT	Yes (2-15m)
REFERENCE TARGET	Receiver
MODEL NUMBER(S)	M11/MV11/47/76a/112
	M11/MV11/48/76b/112
OUTPUT: Transistor, Normally Open and Normally Closed (programmable)	/47 PNP, sourcing /48 NPN, sinking
LOAD CURRENT	200mA max.
LEAKAGE CURRENT	≤10µA
VOLTAGE DROP	≤2.5VDC
SHORT CIRCUIT AND OVERLOAD PROTECTION	Yes
SUPPLY VOLTAGE	10-30VDC
VOLTAGE RIPPLE	10%
CURRENT CONSUMPTION	≤25mA
RESPONSE TIME	Programmable
READINESS DELAY	≤400ms
SWITCHING FREQUENCY	Programmable
PROTECTION (IEC)	IP68
LIGHT SPOT DIAMETER	500mm at a range of 15m
LIGHT SOURCE	Visible red LED 660nm
TEMPERATURE RANGE	<i>WORKING</i> -13°F to +158°F
	<i>STORAGE</i> -40°F to +158°F
HOUSING MATERIAL	Crastin
<i>LENS</i>	Scratch-resistant coated plastic
<i>CONNECTOR/DOVETAIL</i>	AlSi
WEIGHT	2.1oz (per housing)
ELECTRICAL CONNECTION	 Quick disconnect type V15
ADDITIONAL DATA	See pages 352-358

Sensing Characteristics

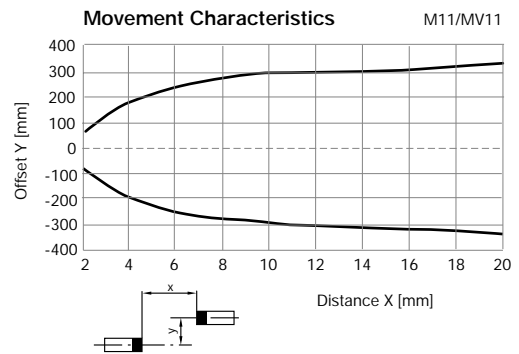
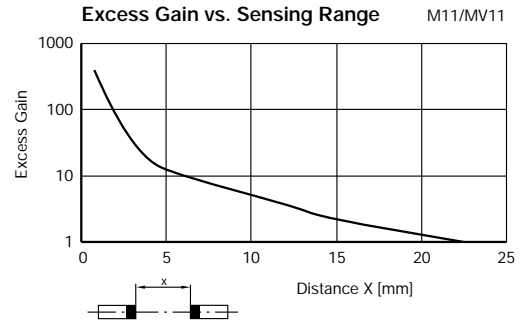

Photoelectric Sensors

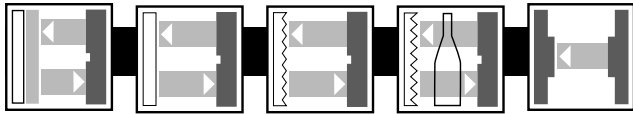

Series Specifications

MLV11 Series Specifications

REVERSE POLARITY PROTECTION	Yes
LED(s)	Yes (3)
OPERATING MODE	Light on/dark on
ELECTROMAGNETIC COMPATIBILITY COMPLIANCE	NEMA ICS5-2000 See page 6
AMBIENT LIGHT RESISTANCE	≤10,000 lux
APPROVALS	Yes

AS-Interface Programming

Address preset to 00, can be changed via the master or with a hand-held addressing device.

IO-Code 1
ID-Code F

Data bits

Bit	Function
D0	switch output
D1	weak signal indication (0=on, 1=off)
D2	normally open/normally closed switch output
D3	input function

Parameter bits

Bit	Function (1/0)
P0	not used
P1	not used
P2	not used
P3	not used

Wiring Diagrams

DC



Quick Disconnect

Note: Wiring diagrams show quick disconnect pin numbers.

V15 Type

MLV11-8-H

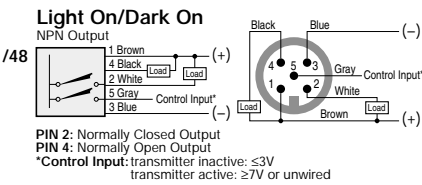
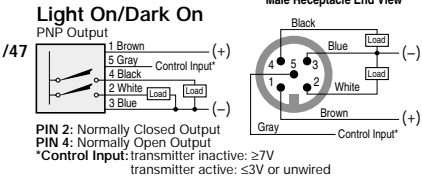

MLV11-8, MLV11-54, M11/MV11

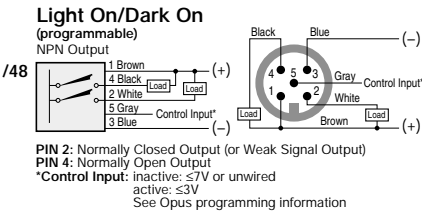
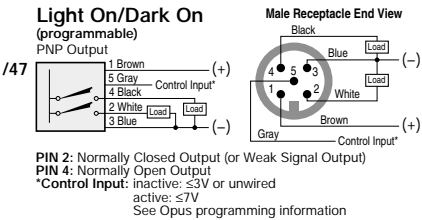

Transmitter (thru-beam models)

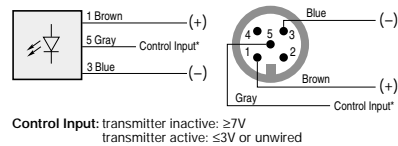

AS-Interface



Quick Disconnect

Note: Wiring diagrams show quick disconnect pin numbers.

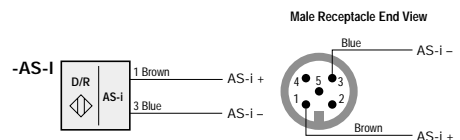

Switch Point Setting

The MLV11 series' switch points are programmed with the membrane push buttons, but other "enhanced" parameters may be programmed using an optical link and connector with either an OPUS hand-held programmer or the OPUS software on a PC.

The MLV11-8-H series (diffused mode with background suppression) is programmable only via a sensitivity adjustment potentiometer on the housing which is used to set the switch points.

Both the push-button programming and the OPUS programming will store the programmed parameters if the supply voltage to the sensor is disconnected. For details on programming with the OPUS hand-held programmer or the OPUS software and its accessories, refer to pages 765-768.

MLV11-8 and MLV11-54 Series Push-button Programming Instructions

There are three ways to set the switch point for these series: manual setting, automatic setting for static operation (for targets that are stationary), and automatic setting for dynamic operation (for targets that are moving).

Manual Push-button Setting



1. If the sensor's push buttons are locked (usually when the sensor is connected to a supply voltage), then simultaneously press the "+" and "-" buttons for five seconds (until the green LED flashes once). The sensor is now unlocked. If the green LED is flashing continuously, then the sensor is already in the automatic "teach" mode, and either the "+" or "-" button must be pressed to reset the sensor to the manual setting mode.



2. Place the target at the desired sensing distance. Adjust the sensitivity of the sensor by pressing the "+" and "-" buttons. Either button can be pressed and held down to repeat the function. The red LED flashes whenever either button is pressed, and the yellow LED indicates the output status. If the red LED does not flash when either button is pressed, then the sensor is either at the end of the adjustable range or it is no longer unlocked, and steps 1 and 2 should be repeated.

Automatic Push-button Setting – Static Mode (for stationary targets)



1. If the sensor's push buttons are locked (usually when the sensor is connected to a supply voltage), then simultaneously press the "+" and "-" buttons for five seconds (until the green LED flashes once). The sensor is now unlocked. If the green LED is flashing continuously, then the sensor is already in "teach" mode, and the supply voltage should be disconnected and re-connected to the sensor and step 1 should be repeated.



2. Place the target at the desired sensing distance. Press the "+" and "-" buttons simultaneously for one second, until the red LED turns off. When the green LED starts to flash, the sensor is in "teach" mode. The green LED will flash briefly at a higher frequency (4 Hz), although the time the green LED is flashing at a higher frequency may be too short to be observed.



3. The green LED flashes at 2 Hz, indicating that the sensor is out of "teach" mode.



4. Press either the "+" or "-" button to store the switch point. The green LED will be lit continuously and the yellow LED will indicate output status. If the red LED is lit, then there is an error, and steps 2, 3, and 4 should be repeated.

Photoelectric Sensors

MLV11 Series Programming

Automatic Push-button Setting – Dynamic Mode (for moving targets)



1. If the sensor's push buttons are locked (usually when the sensor is connected to a supply voltage), then simultaneously press "+" and "-" buttons for five seconds (until the green LED flashes once). The sensor is now unlocked. If the green LED is flashing continuously, then the sensor is already in the "teach" mode, and step 2 should be skipped.



2. Press the "+" and "-" buttons simultaneously for one second, until the red LED turns off. The green LED will be flashing at 2 Hz which indicates the sensor is in "teach" mode.



3. Move the target perpendicularly past the sensor at the desired sensing distance. The green LED will flash briefly at a higher switching frequency (4 Hz), although the time the green LED is flashing at a higher frequency may be too short to be observed. When the green LED flashes at 2 Hz again, the sensor is out of "teach" mode.



4. Press either the "+" or "-" button to store the switch point. The green LED will be lit continuously and the yellow LED will indicate output status. If the red LED is lit, then there is an error, and steps 2, 3, and 4 should be repeated.

M11/MV11 Series Push-button Programming Instructions

There are two ways to set the switch point for this series: manual setting and automatic setting.

Manual Push-button Setting

1. Align the transmitter and receiver facing each other, with the light beam between the two unobstructed.



2. If the sensor's push buttons are locked (usually when the sensor is connected to a supply voltage), then simultaneously press "+" and "-" buttons (which are only located on the receiver housing) for five seconds (until the green LED flashes once). The sensor is now unlocked.
3. Adjust the sensitivity of the sensor by pressing the "+" or "-" button. Either button can be pressed and held down to repeat the function. The red LED flashes whenever either button is pressed, and the yellow LED indicates output status. If the red LED does not flash when either button is pressed, then the sensor is either at the end of the adjustable range or it is no longer unlocked, and steps 1, 2, and 3 should be repeated.

Automatic Push-button Setting

1. Align the transmitter and receiver, with the light beam between the two unobstructed.



2. If the sensor's push buttons are locked (usually when the sensor is connected to a supply voltage), then simultaneously press "+" and "-" buttons for five seconds (until the green LED flashes once). The sensor is now unlocked.



3. Press the "+" and "-" buttons simultaneously for two seconds (until the green LED flashes) then release both keys. The green LED will be flashing at 2 Hz which indicates the sensor is in "teach" mode.
4. The "teach" mode is completed when the green LED remains on.

Parameter Settings

An optical interface (used with a PC or a hand-held device) is used to set the optional "enhanced" parameters. The factory settings are underlined. Optical interface programming is not available for the MLV11-8-H series. Please see pages 765-768 for more details on these parameters and using the OPUS software or handheld programmer.

Outputs

- N.O. and failure output (weak signal output)
- N.C. and failure output (weak signal output)
- Antivalent (N.O. and N.C.)

Optical failure control

- Static
- Dynamic
- Off

Switching frequency/Response time

- 1kHz / 0.5ms
- 500Hz / 1ms
- 250Hz / 2ms
- 100Hz / 5ms
- 50Hz / 10ms
- 20Hz / 25ms

Hysteresis (not available for M11/MV11 series)

- Small
- Standard
- Large

Time function 1

- No
- On delay (0.1s to 25.5s in 0.1s increments)

Time function 2

- No
- Off delay (0.1s to 25.5s in 0.1s increments)
- Limit timer (pulse lengthener) (1ms to 255ms in 1ms increments)
- One-shot (1ms to 255ms in 1ms increments)

Pulse frequency (not available for M11/MV11 series)

- Pulse Frequency 1
- Pulse Frequency 2
- Pulse Frequency 3

Keypad locking (push-button tamper-proofing)

- Off
- Automatic
- Always

Input function

- None
- Test function (not available for M11/MV11 series)
- NC/NO-Switch-over
- Logic AND
- Logic OR
- Logic XOR
- Teach in (not available for M11/MV11 series)
- Optical failure test (not available for M11/MV11 series)
- Latch (not available for M11/MV11 series)
- D-Flipflop (not available for M11/MV11 series)

Input inverted

- All control input functions can be inverted

Parameterization disable

- Off
- On

Photoelectric Sensors

Dimensions (mm)

MLV11-8-H

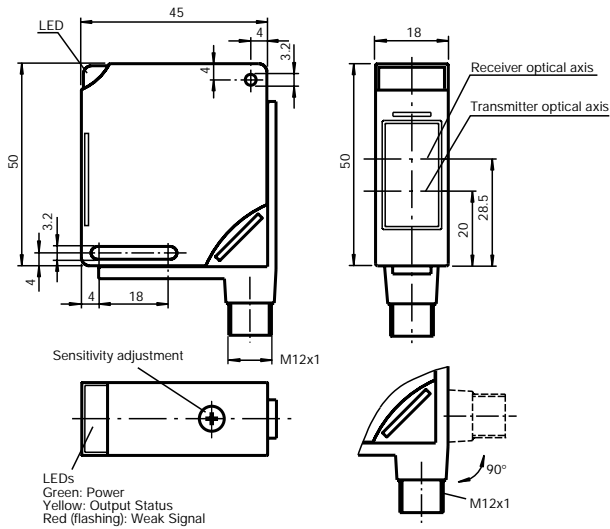

MLV11-8, MLV11-54

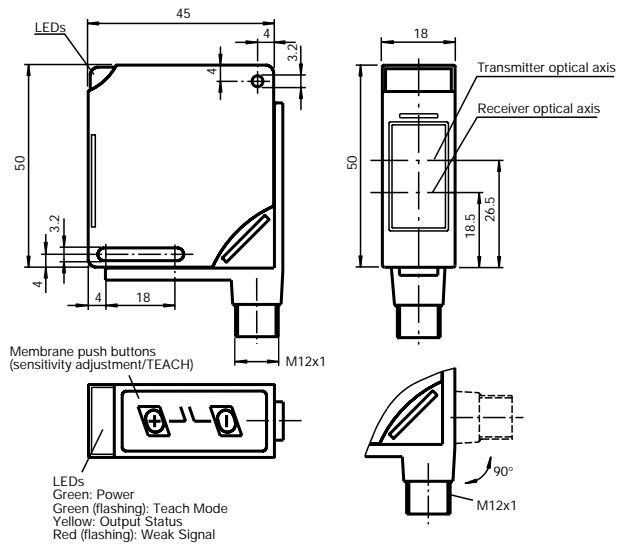

M11/MV11

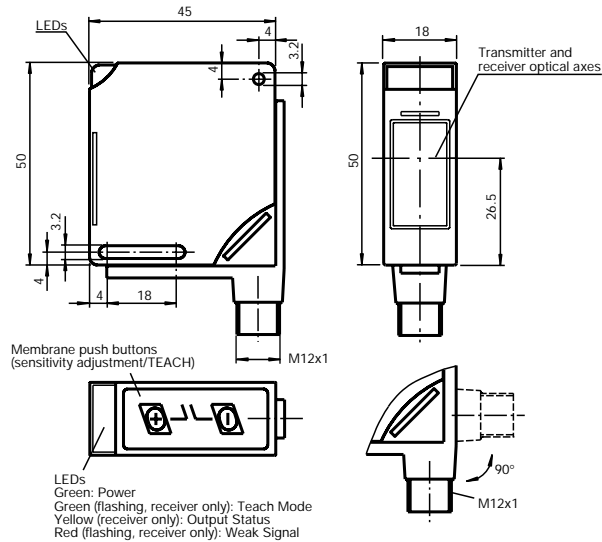

Accessories

(Dimensions in mm)

Mounting Bracket Model OMH-MLV11

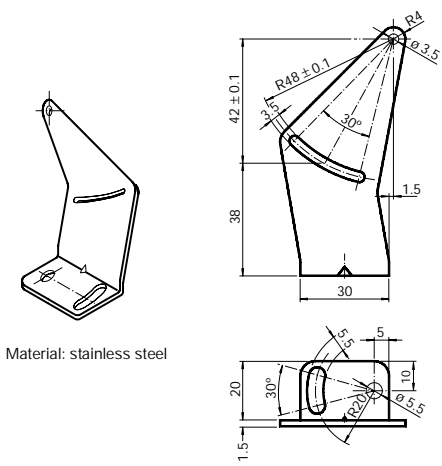

Dovetail Mounting Clamp Model OMH-MLV11-K

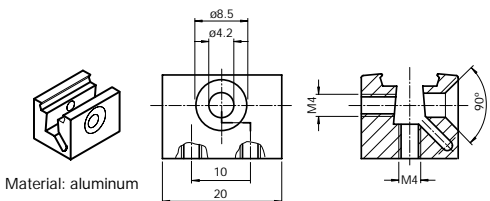

Optical Link Model MLV11/RL27-CLIP

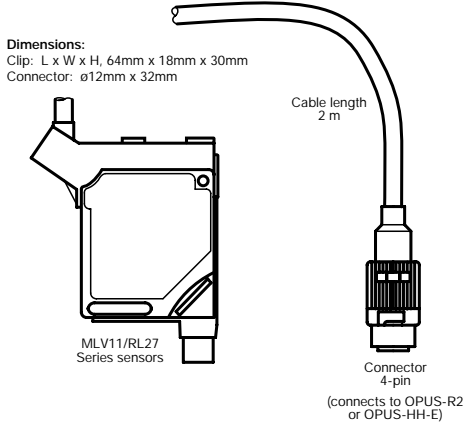

Optical Link-to-Serial Port Connector Model OPUS-R2

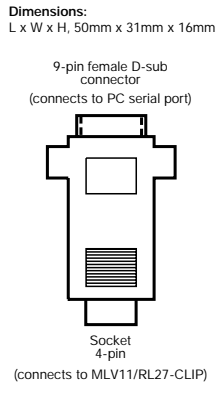

OPUS Software Model OPUS-PC (two 3.5" disks)

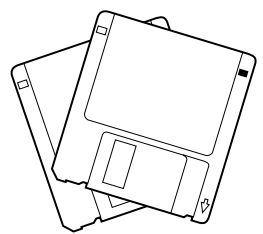

OPUS Hand-held Programmer Model OPUS-HH-E

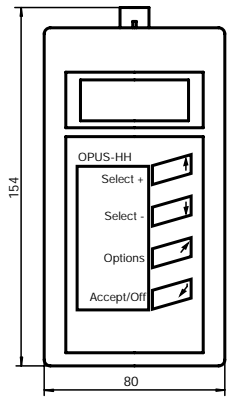

See pages 765-768 for OPUS programming information.



See pages 769-828 for cordsets



See pages 829-840 additional accessories for photoelectric sensors

Photoelectric MLV11 Series Power Touch Style



MLV13 Series Miniature Style Sensors

- Light on/dark on modes determined by wiring
- Thru-hole or dovetail mounting
- Visible red LED for alignment



Diffused Mode

See page 364

Features:

- Adjustable sensing range
- Weak signal LED

Sensing Range: 400mm

Outputs: NPN, PNP

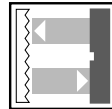

Retro-Reflective Mode

See page 365

Features:

- Sensing range can be increased with H85 reflector
- Weak signal LED

Sensing Range: 6m

Outputs: NPN, PNP

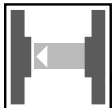

Thru-Beam Mode

See page 366

Features:

- Large offset allowance for alignment
- Weak signal LED

Sensing Range: 15m



Outputs: NPN, PNP

See pages 367-370 for MLV13 series specifications, wiring and dimensions.

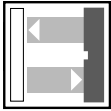
Photoelectric Sensors



Diffused Mode

Specifications				
SENSING RANGE		5-400mm	5-400mm	5-400mm
SENSITIVITY ADJUSTMENT		Yes (50-400mm)	Yes (50-400mm)	Yes (50-400mm)
REFERENCE TARGET		100 x 100mm white test card	100 x 100mm white test card	100 x 100mm white test card
MODEL NUMBER(S)	/30	MLV13-8-400/30/40b/115	MLV13-8-400/30/40b/95	MLV13-8-400/30/40b/73c
	/32	MLV13-8-400/32/40b/115	MLV13-8-400/32/40b/95	MLV13-8-400/32/40b/73c
OUTPUT: Transistor, Normally Open or Normally Closed	/30	NPN, sinking	NPN, sinking	NPN, sinking
	/32	PNP, sourcing	PNP, sourcing	PNP, sourcing
SUPPLY VOLTAGE		10-30VDC	10-30VDC	10-30VDC
LED(s)		Yes (2)	Yes (2)	Yes (2)
RESPONSE TIME		≤1.0ms	≤1.0ms	≤1.0ms
READINESS DELAY		≤30ms	≤30ms	≤30ms
SWITCHING FREQUENCY		500Hz	500Hz	500Hz
ELECTRICAL CONNECTION		 2-meter cable, PVC covered 4-conductor, #26AWG	 Quick disconnect type V31	 Quick disconnect type V1
ADDITIONAL DATA		<i>See pages 367-370</i>		

Sensing Characteristics

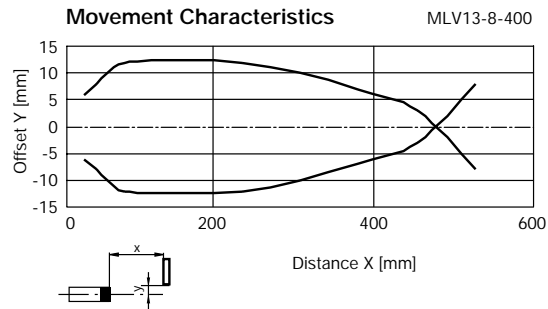
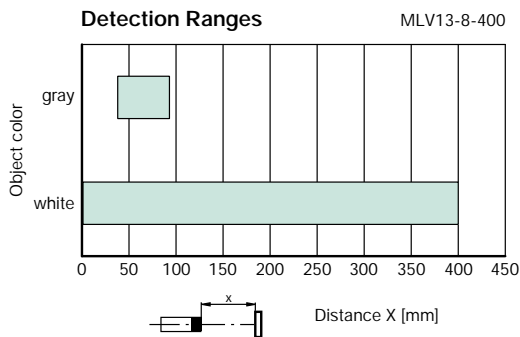

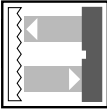

Retro-Reflective Mode

Photoelectric MLV13 Series Miniature Style

Specifications			
SENSING RANGE	0-6m	0-6m	0-6m
SENSITIVITY ADJUSTMENT	Yes	Yes	Yes
REFERENCE TARGET	C110-2 reflector	C110-2 reflector	C110-2 reflector
POLARIZED FILTER	Yes	Yes	Yes
MODEL NUMBER(S)	MLV13-54/30/40b/115	MLV13-54/30/40b/95	MLV13-54/30/40b/73c
	MLV13-54/32/40b/115	MLV13-54/32/40b/95	MLV13-54/32/40b/73c
OUTPUT: Transistor, Normally Open or Normally Closed	/30 NPN, sinking	NPN, sinking	NPN, sinking
	/32 PNP, sourcing	PNP, sourcing	PNP, sourcing
SUPPLY VOLTAGE	10-30VDC	10-30VDC	10-30VDC
LED(s)	Yes (2)	Yes (2)	Yes (2)
RESPONSE TIME	≤1.0ms	≤1.0ms	≤1.0ms
READINESS DELAY	≤80ms	≤80ms	≤80ms
SWITCHING FREQUENCY	500Hz	500Hz	500Hz
LIGHT SPOT DIAMETER	200mm at a range of 6m	200mm at a range of 6m	200mm at a range of 6m
ELECTRICAL CONNECTION	 2-meter cable, PVC covered 4-conductor, #26AWG	 Quick disconnect type V31	 Quick disconnect type V1
ADDITIONAL DATA	<i>See pages 367-370</i>		

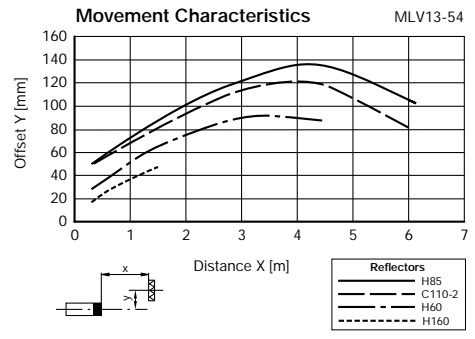
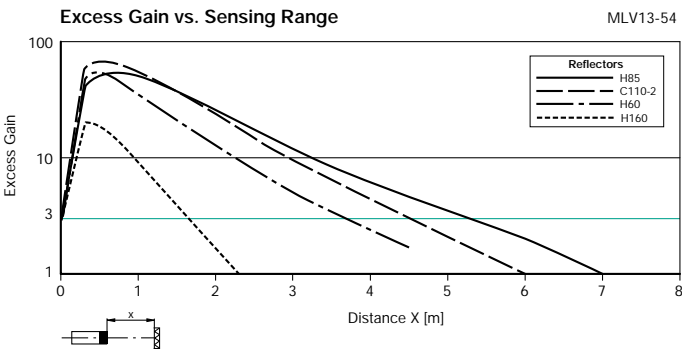

Sensing Characteristics

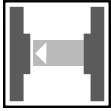

Photoelectric Sensors



Thru-Beam Mode

Specifications		
SENSING RANGE	0-15m	0-15m
SENSITIVITY ADJUSTMENT	Yes (2-15m)	Yes (2-15m)
REFERENCE TARGET	Receiver	Receiver
MODEL NUMBER(S)	M13/MV13/30/40b/95	M13/MV13/30/40b/73c
	M13/MV13/32/40b/95	M13/MV13/32/40b/73c
OUTPUT: Transistor, Normally Open or Normally Closed	/30 NPN, sinking	NPN, sinking
	/32 PNP, sourcing	PNP, sourcing
SUPPLY VOLTAGE	10-30VDC	10-30VDC
LED(s)	Yes (3)	Yes (3)
RESPONSE TIME	≤3.0ms	≤3.0ms
READINESS DELAY	≤30ms	≤30ms
SWITCHING FREQUENCY	150Hz	150Hz
ELECTRICAL CONNECTION	 Quick disconnect type V31	 Quick disconnect type V1
ADDITIONAL DATA	<i>See pages 367-370</i>	

Sensing Characteristics

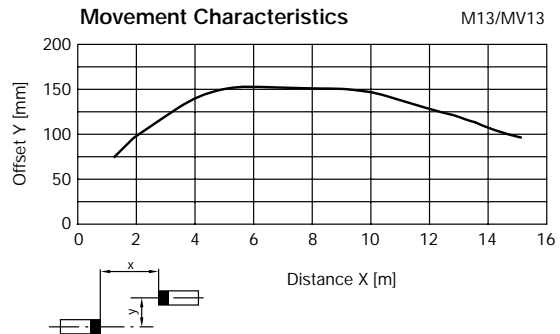
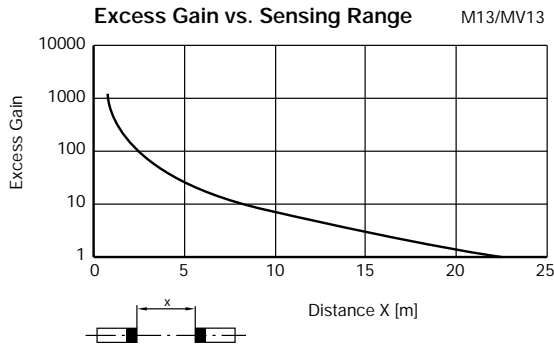

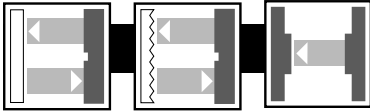

Series Specifications

MLV13 Series Specifications	
LOAD CURRENT	200mA max.
VOLTAGE DROP	≤2.5VDC
SHORT CIRCUIT AND OVERLOAD PROTECTION	Yes
REVERSE POLARITY PROTECTION	Yes
VOLTAGE RIPPLE	10%
CURRENT CONSUMPTION	≤25mA
OPERATING MODE	Light on/dark on
ELECTROMAGNETIC COMPATIBILITY COMPLIANCE	NEMA ICS5-2000 See page 6
PROTECTION (IEC)	IP67
LIGHT SOURCE	Visible red LED
AMBIENT LIGHT PROTECTION	≤10,000 lux
TEMPERATURE RANGE	<i>WORKING</i> -14°F to +158°F <i>STORAGE</i> -40°F to +158°F
HOUSING MATERIAL	Crastin
<i>LENS</i>	Scratch-resistant plastic
WEIGHT	1.4oz (per housing)
APPROVALS	Yes

Photoelectric MLV13 Series Miniature Style



Photoelectric Sensors

Wiring Diagrams

DC



Cable Connection

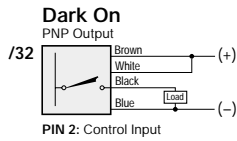
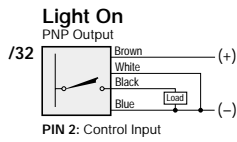
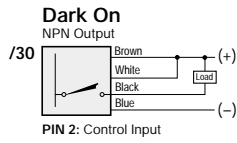
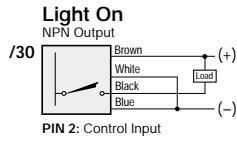

Quick Disconnect

Note: Wiring diagrams show quick disconnect pin numbers.

V31 Type

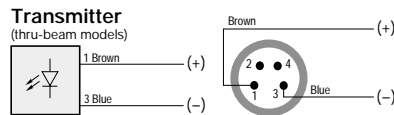
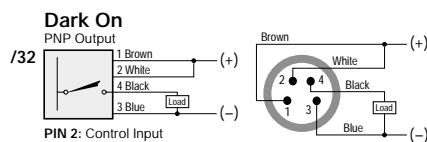
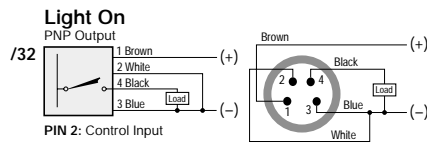
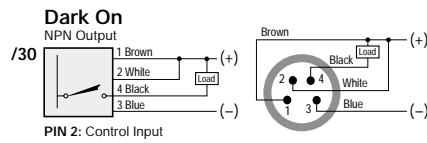
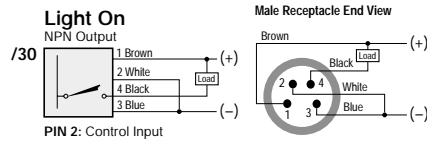

V1 Type

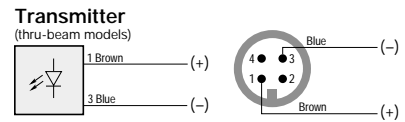
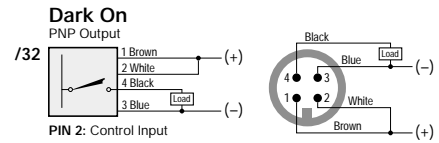
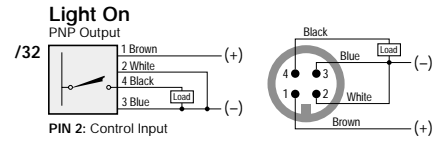
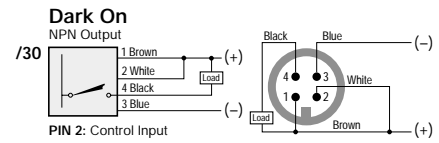
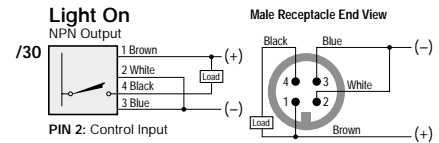

Dimensions (mm)

MLV13.../115

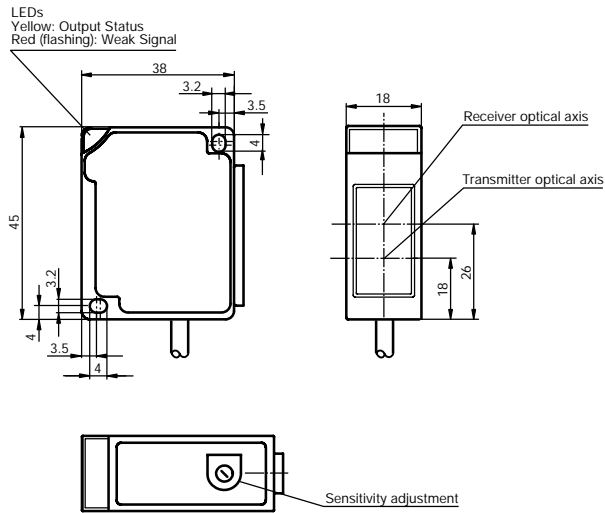

**M13/MV13.../95
MLV13.../95**

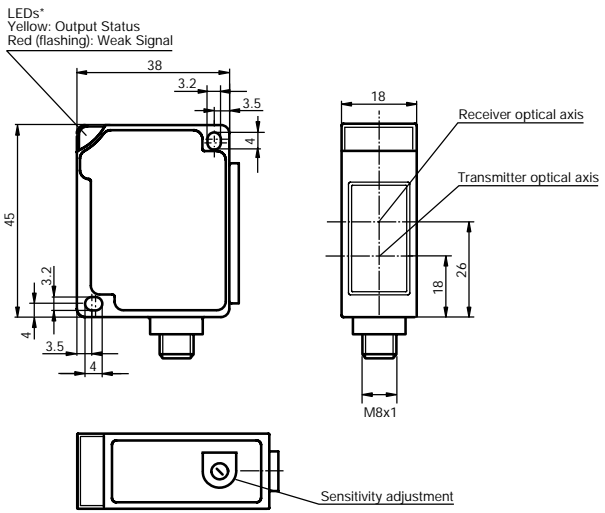

**M13/MV13../73c
MLV13../73c**

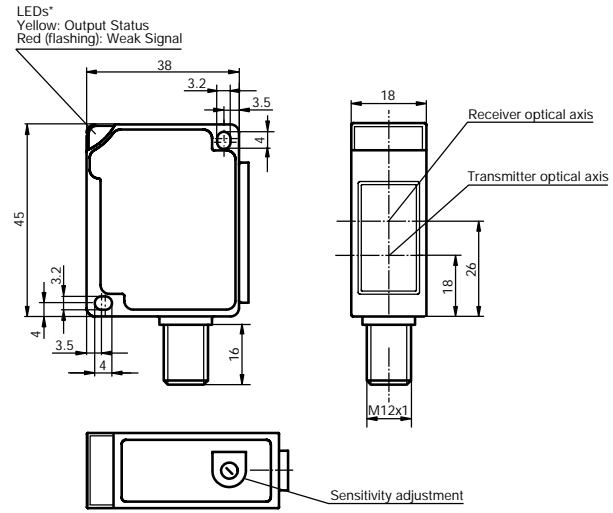

*Thru-beam models: green (power) LED on transmitter only; yellow (output status) and red (flashing)(weak signal) on receiver only.

Photoelectric MLV13 Series Miniature Style

Photoelectric Sensors

Accessories

(Dimensions in mm)

Dovetail Mounting Clamp Model OMH-MLV11-K

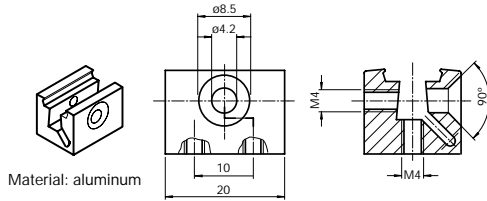

See pages
769-828 for
cordsets



See pages 829-840
additional accessories
for photoelectric sensors



MLV14 Series AccuTouch Style Sensors

- Push-button automatic programming for optimal sensitivity
- Simple light on/dark on mode selection
- Separate teach input allows remote programming on DC models

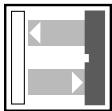

Diffused Mode

See page 406

Features:

- DC and AC/DC models available
- Weak signal output available on DC models

Sensing Range: 400mm

Outputs: NPN and PNP, thyristor

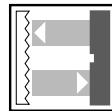

Retro-Reflective Mode

See page 407

Features:

- Weak signal output available on DC models
- Visible light source for easy alignment

Sensing Range: 3m

Outputs: NPN and PNP, thyristor



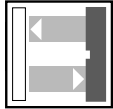

See pages 408-412 for MLV14 series specifications, programming, wiring and dimensions.

Photoelectric Sensors





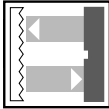

Diffused Mode

Photoelectric MLV14 Series AccuTouch Style

Specifications					
SENSING RANGE		400mm	400mm	400mm	400mm
SENSITIVITY ADJUSTMENT		Yes	Yes	Yes	Yes
REFERENCE TARGET		100 x 100mm white test card	100 x 100mm white test card	100 x 100mm white test card	100 x 100mm white test card
MODEL NUMBER(S)		MLV14-8-400/49/82a/115/123	MLV14-8-400/49/82a/123/124	—	—
		—	—	MLV14-8-400/115/132	MLV14-8-400/131/132
OUTPUT: Normally Open or Normally Closed	/49 (DC)	1 NPN and 1 PNP	1 NPN and 1 PNP	—	—
	/132 (AC/DC)	—	—	Thyristor	Thyristor
WEAK SIGNAL OUTPUT		PNP, 10mA max.	PNP, 10mA max.	No	No
LOAD CURRENT		200mA max.	200mA max.	8-200mA	8-200mA
LEAKAGE CURRENT		≤10μA	≤10μA	≤1.7mA	≤1.7mA
VOLTAGE DROP		≤2VDC	≤2VDC	≤6V@200mA	≤6V@200mA
SHORT CIRCUIT AND OVERLOAD PROTECTION		Yes	Yes	Yes	Yes
REVERSE POLARITY PROTECTION		Yes	Yes	Nonpolarity sensitive	Nonpolarity sensitive
SUPPLY VOLTAGE		10-30VDC	10-30VDC	20-250VAC/20-300VDC	20-250VAC/20-300VDC
VOLTAGE RIPPLE		10%	10%	—	—
CURRENT CONSUMPTION		≤35mA	≤35mA	—	—
RESPONSE TIME		≤0.34ms	≤0.34ms	≤25.0ms	≤25.0ms
READINESS DELAY		≤200ms	≤200ms	≤250ms	≤250ms
SWITCHING FREQUENCY		1.5kHz	1.5kHz	20Hz	20Hz
ELECTRICAL CONNECTION		 2-meter cable, PVC covered 5-conductor, #22AWG	 Quick disconnect type V15	 2-meter cable, PVC covered 2-conductor, #18AWG	 Quick disconnect type V12
ADDITIONAL DATA	<i>See pages 408-412</i>				



Retro-Reflective Mode

Specifications				
SENSING RANGE	3m	3m	3m	3m
SENSITIVITY ADJUSTMENT	Yes	Yes	Yes	Yes
REFERENCE TARGET	ORR50 reflector	ORR50 reflector	ORR50 reflector	ORR50 reflector
POLARIZED FILTER	Yes	Yes	Yes	Yes
MODEL NUMBER(S)	MLV14-55/49/82a/115/123	MLV14-55/49/82a/123/124	—	—
	—	—	MLV14-55/115/132	MLV14-55/131/132
OUTPUT: Normally Open or Normally Closed	/49 (DC) 1 NPN and 1 PNP	1 NPN and 1 PNP	— Thyristor	— Thyristor
WEAK SIGNAL OUTPUT	PNP, 10mA max.	PNP, 10mA max.	No	No
LOAD CURRENT	200mA max.	200mA max.	8-200mA	8-200mA
LEAKAGE CURRENT	≤10μA	≤10μA	≤1.7mA	≤1.7mA
VOLTAGE DROP	≤2VDC	≤2VDC	≤6V@200mA	≤6V@200mA
SHORT CIRCUIT AND OVERLOAD PROTECTION	Yes	Yes	Yes	Yes
REVERSE POLARITY PROTECTION	Yes	Yes	Nonpolarity sensitive	Nonpolarity sensitive
SUPPLY VOLTAGE	10-30VDC	10-30VDC	20-250VAC/20-300VDC	20-250VAC/20-300VDC
VOLTAGE RIPPLE	10%	10%	—	—
CURRENT CONSUMPTION	≤35mA	≤35mA	—	—
RESPONSE TIME	≤0.34ms	≤0.34ms	≤25.0ms	≤25.0ms
READINESS DELAY	≤200ms	≤200ms	≤250ms	≤250ms
SWITCHING FREQUENCY	1.5kHz	1.5kHz	20Hz	20Hz
ELECTRICAL CONNECTION	 2-meter cable, PVC covered 5-conductor, #22AWG	 Quick disconnect type V15	 2-meter cable, PVC covered 2-conductor, #18AWG	 Quick disconnect type V12
ADDITIONAL DATA	<i>See pages 408-412</i>			

Photoelectric Sensors

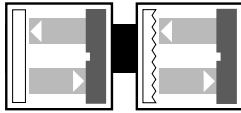

Series Specifications

MLV14 Series Specifications	
LED(s)	Yes (3)
OPERATING MODE	Light on/dark on programmable
ELECTROMAGNETIC COMPATIBILITY COMPLIANCE	NEMA ICS5-2000 See page 6
PROTECTION (IEC)	IP67
LIGHT SOURCE	Visible red LED 660nm
AMBIENT LIGHT RESISTANCE	≤10,000 lux
TEMPERATURE RANGE	-4°F to +158°F
HOUSING MATERIAL	Crastin
LENS	Acrylic
APPROVALS	<div style="display: flex; align-items: center;"> <div style="text-align: center; margin-right: 10px;"> LISTED </div> <div>General Purpose</div> </div>
	Yes
	<div style="display: flex; align-items: center;"> <div style="text-align: center; margin-right: 10px;"> CE </div> <div style="text-align: center; margin-right: 10px;"> CERTIFIED </div> <div>General Purpose</div> </div>
	Yes

Wiring Diagrams

DC



Cable Connection

Light On/Dark On (programmable)

NPN and PNP Outputs

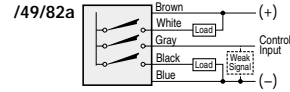

Gray Wire: Control input for remote programming or weak signal output



Quick Disconnect

Note: Wiring diagrams show quick disconnect pin numbers.

V15 Type

Light On/Dark On (programmable)

NPN and PNP Outputs

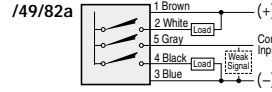

Male Receptacle End View

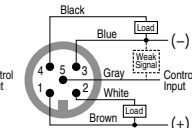

Pin 5: Control input for remote programming or weak signal output

AC/DC



Cable Connection

Light On/Dark On (programmable)

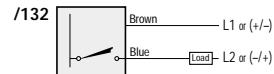

Quick Disconnect

Note: Wiring diagrams show quick disconnect pin numbers.

V12 Type

Light On/Dark On (programmable)

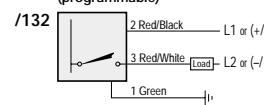

Male Receptacle End View

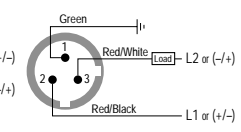

Push Button Programming

Light On Operation

1. Press and hold the -/+ buttons for approximately 4 seconds to activate the "Teach" mode. When the green LED turns off, release the -/+ buttons. The green LED turns on again, which indicates the "Teach" mode is active.
2. Place the target in the application sensing position, and then press and hold the -/+ buttons for approximately 2 seconds to learn the target. When the red and green LEDs alternately flash, indicating the proper storage of information, release the -/+ buttons.
3. Remove the target and press and hold the -/+ buttons for approximately 2 seconds to learn the "no target" position. When the red and green LEDs simultaneously flash, denoting the proper storage of information, release the -/+ buttons. The LEDs will continue to flash for approximately 10 seconds before going to normal operation.



Dark On Operation

1. Press and hold the -/+ buttons for approximately 4 seconds to activate the "Teach" mode. When the green LED turns off, release the -/+ buttons. The green LED turns on again, which indicates the "Teach" mode is active.
2. With no target present, press and hold the -/+ buttons for approximately 2 seconds. Release the -/+ buttons when the red and green LEDs alternately flash, indicating the proper storage of information.
3. Place the target in the application sensing position, and then press and hold the -/+ buttons for approximately 2 seconds to learn the target. When the red and green LEDs simultaneously flash, indicating the proper storage of information, release the -/+ buttons.

After the above Light On or Dark On programming procedure is completed, no further programming is necessary, and the sensor is fully operational. However, incremental adjustments may be made by pressing the + button to increase the gain (the green LED flashes off when this is done), or by pressing the - button to decrease the gain (the red LED flashes on when this is done). Two minutes after the last button is pressed, the sensor will automatically "lock out," after which the incremental adjustments may not be made. Any programming step in which the red LED stays on for at least 2 seconds indicates an error, and the programming must be repeated from the beginning.

Remote Programming (For DC models only)

DC models (/49) have the option of either a weak signal output, which is the factory default setting, or a remote programming input.

Activating the Remote Programming Mode

1. Before power-up, press and hold the + button.
2. Apply power to the sensor, then release the + button. The green LED will flash and then stay on.

Light On Remote Programming

1. Place the target in the application sensing position. Connect the gray wire to 10-30VDC (+Vin) for 1 second minimum. The red and green LEDs will alternately flash, indicating the proper storage of information.
2. Remove the target. Disconnect the gray wire from 10-30VDC (+Vin) for 1 second minimum. The red and green LEDs will simultaneously flash, denoting the proper storage of information.

Dark On Remote Programming

1. With no target present, connect the gray wire to 10-30VDC (+Vin) for 1 second minimum. The red and green LEDs will alternately flash, indicating the proper storage of information.
2. Place the target in the application sensing position. Disconnect the gray wire from 10-30VDC (+Vin) for 1 second minimum. The red and green LEDs will alternately flash, indicating the proper storage of information.

With the target present/absent positions stored by the above steps, no further programming is necessary.

Activating the Alarm Output (Factory Default Setting):

1. Before power-up, press and hold the - button.
2. Apply power to the sensor, then release the - button. The green LED will go on.

Photoelectric Sensors

Dimensions (mm)

Photoelectric MLV14 Series AccuTouch Style

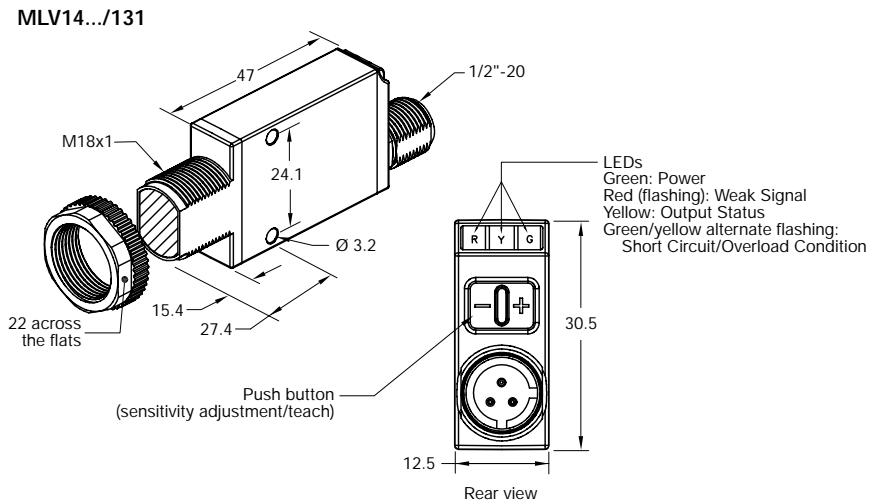
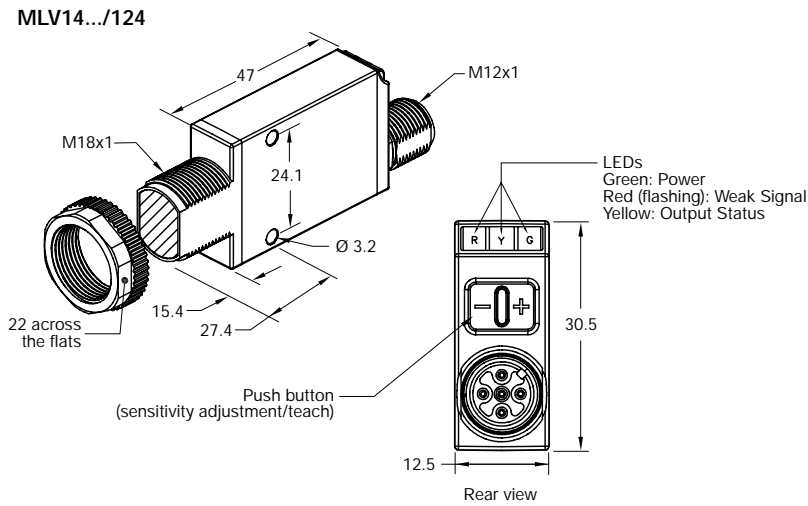
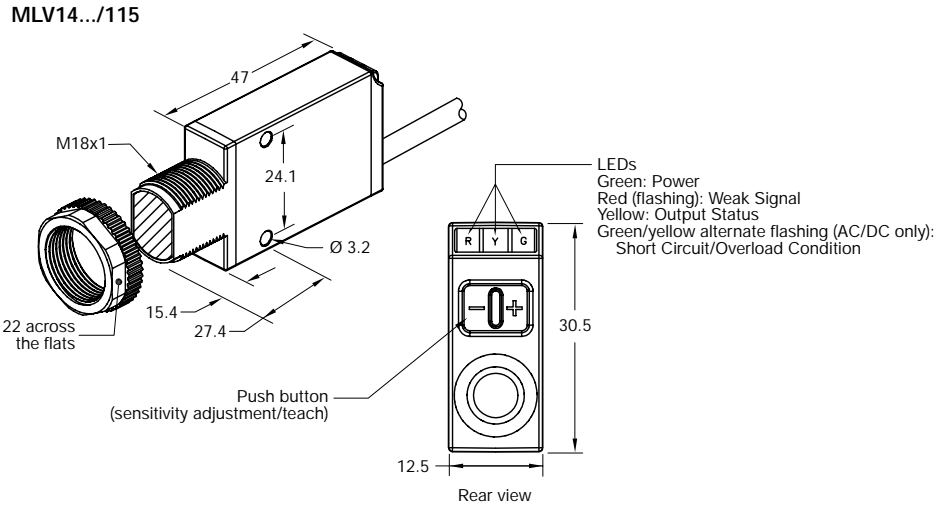

Accessories

(Dimensions in mm)

Side Mounting Bracket Model OMH-MLV14-1

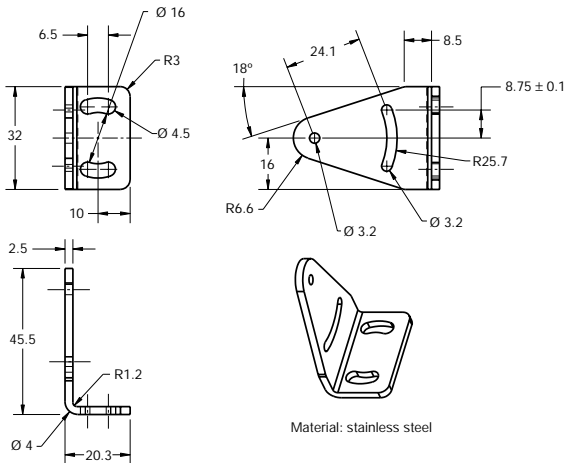

Cylindrical Mounting Bracket Model OMH-MLV14

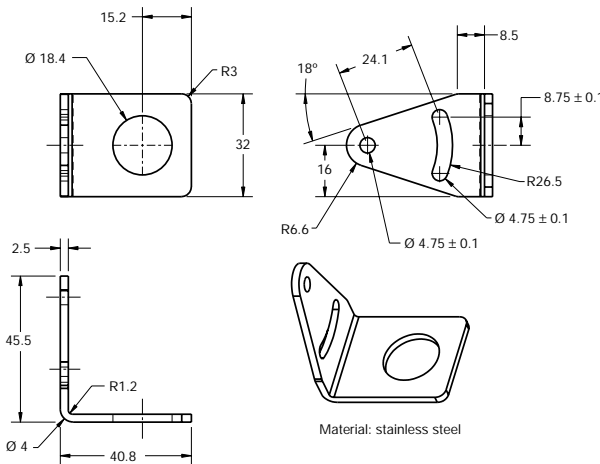

Photoelectric MLV14 Series AccuTouch Style



See pages
769-828 for
cordsets



See pages 829-840
additional accessories
for photoelectric sensors



MLV40 Series Miniature Style Sensors

- Rugged metal housing
- Compact 14mm (9/16") wide housing
- LED indication of switch status and signal strength



Diffused Mode with Background Suppression

See page 372

Features:

- Fixed-field and adjustable range models
- Consistent detection of light and dark objects

Sensing Ranges: 80mm, 150mm

Outputs: NPN, PNP

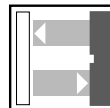

Diffused Mode

See page 373

Features:

- Adjustable sensitivity
- Complementary outputs

Sensing Range: 500mm

Outputs: NPN, PNP

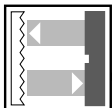

Retro-Reflective Mode

See pages 374-375

Features:

- Polarized filter models reliably detect shiny objects
- Cabled models allow operating mode selection by wiring

Sensing Ranges: 1m, 2m

Outputs: NPN, PNP



Retro-Reflective Mode for Clear Object Detection

See page 376

Features:

- Detects clear glass and plastics
- Single optical axis for transmitter and receiver allows close detection of target

Sensing Range: 400mm

Outputs: NPN, PNP

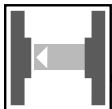

Thru-Beam Mode

See page 377

Features:

- Large excess gain at 5 meter distance
- High resistance to ambient lighting

Sensing Range: 5m

Outputs: NPN, PNP

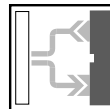

Fiber Optic Diffused and Thru-Beam Mode

See page 378

Features:

- Adjustable sensitivity
- Wide selection of mating fiber optic heads and lengths

Sensing Range: Determined by fiber optic cable

Outputs: NPN, PNP





See pages 379-382 for MLV40 series specifications, wiring and dimensions.

Photoelectric Sensors

Photoelectric MLV40 Series Miniature Style



Diffused Mode with Background Suppression

Specifications		10-80mm	10-80mm	10-150mm	10-150mm
SENSING RANGE		10-80mm	10-80mm	10-150mm	10-150mm
SENSITIVITY ADJUSTMENT		No	No	Yes (10mm to 150mm)	Yes (10mm to 150mm)
BACKGROUND SUPPRESSION		From 90mm	From 90mm	Adjustable	Adjustable
BLACK/WHITE DIFFERENTIAL*		<8mm	<8mm	<10%	<10%
MODEL NUMBER(S)		MLV40-8-H-80/47/115	MLV40-8-H-80/47/92	—	—
		MLV40-8-H-80/48/115	MLV40-8-H-80/48/92	—	—
		MLV40-8-H-80/49/115	MLV40-8-H-80/49/92	MLV40-8-H-150-65/40a/49/115	MLV40-8-H-150-65/40a/49/92
OUTPUT: Transistor					
		/47	2 PNP	2 PNP	—
		/48	2 NPN	2 NPN	—
		/49	1 NPN and 1 PNP	1 NPN and 1 PNP	1 NPN and 1 PNP
SUPPLY VOLTAGE		10-30VDC	10-30VDC	10-30VDC	10-30VDC
LED(s)		Yes (1)	Yes (1)	Yes (1)	Yes (1)
CURRENT CONSUMPTION		≤40mA	≤40mA	≤40mA	≤40mA
OPERATING MODE		Light on/dark on (D.O. for /49)	Light on/dark on (D.O. for /49)	Light on/dark on	Light on/dark on
RESPONSE TIME		≤5.0ms	≤5.0ms	≤5.0ms	≤5.0ms
SWITCHING FREQUENCY		70Hz	70Hz	70Hz	70Hz
LIGHT SPOT DIAMETER		≈10mm at a range of 80mm	≈10mm at a range of 80mm	≈10mm at a range of 80mm	≈10mm at a range of 80mm
LIGHT BEAM ANGLE		≈7°	≈7°	≈7°	≈7°
LIGHT SOURCE		Infrared LED	Infrared LED	Infrared LED	Infrared LED
AMBIENT LIGHT RESISTANCE		≤100,000 lux	≤100,000 lux	≤100,000 lux	≤100,000 lux
ELECTRICAL CONNECTION		 2-meter cable, PVC covered 4-conductor	 Quick disconnect type V1	 2-meter cable, PVC covered 4-conductor	 Quick disconnect type V1
ADDITIONAL DATA		<i>See pages 379-382</i>			

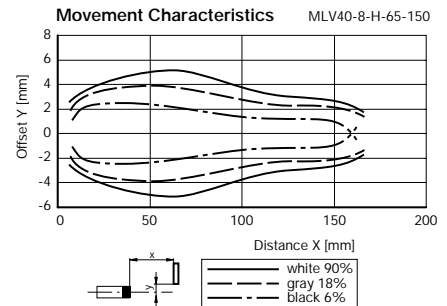
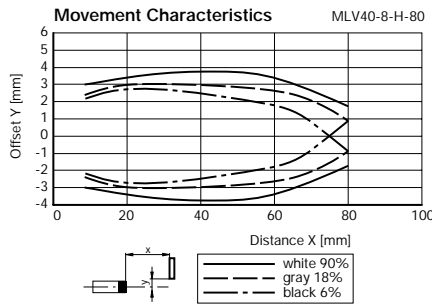
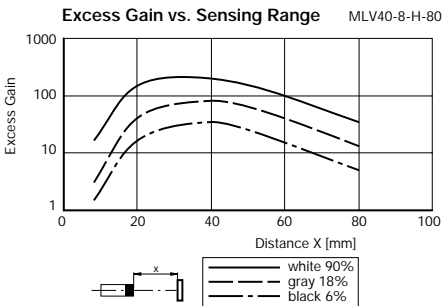

*Difference in sensing range between 90% white test card and 6% black test card

Sensing Characteristics

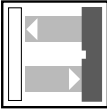



Diffused Mode

Specifications		
SENSING RANGE	10-500mm	10-500mm
SENSITIVITY ADJUSTMENT	Yes (100-500mm)	Yes (100-500mm)
MODEL NUMBER(S)	MLV40-8-500/47/115	MLV40-8-500/47/92
	MLV40-8-500/48/115	—
OUTPUT: Transistor, Normally Open and Normally Closed	/47	PNP
	/48	NPN
SUPPLY VOLTAGE	10-30VDC	10-30VDC
LED(s)	Yes (1)	Yes (1)
CURRENT CONSUMPTION	≤40mA	≤40mA
OPERATING MODE	Light on/dark on	Light on/dark on
RESPONSE TIME	≤1.0ms	≤1.0ms
SWITCHING FREQUENCY	500Hz	500Hz
LIGHT SPOT DIAMETER	≈30mm at a range of 500mm	≈30mm at a range of 500mm
LIGHT BEAM ANGLE	≈4°	≈4°
LIGHT SOURCE	Infrared LED	Infrared LED
AMBIENT LIGHT RESISTANCE	≤50,000 lux	≤50,000 lux
ELECTRICAL CONNECTION	 2-meter cable, PVC covered 4-conductor	 Quick disconnect type V1
ADDITIONAL DATA	<i>See pages 379-382</i>	

Sensing Characteristics

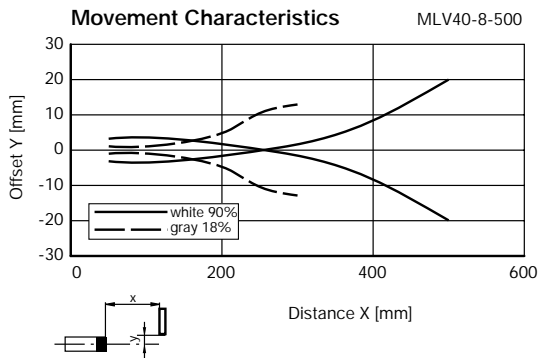
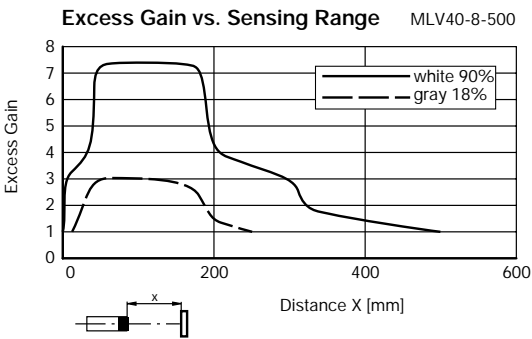



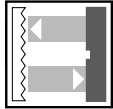

Photoelectric Sensors



Retro-Reflective Mode

Photoelectric MLV40 Series Miniature Style

Specifications					
SENSING RANGE		100mm-1m	100mm-1m	100mm-2m	100mm-2m
SENSITIVITY ADJUSTMENT		No	No	No	No
REFLECTOR DISTANCE		100mm-1m	100mm-1m	100mm-2m	100mm-2m
POLARIZED FILTER		Yes	Yes	No	No
MODEL NUMBER(S)		MLV40-54/47/115	MLV40-54/47/92	MLV40-6/47/115	MLV40-6/47/92
		MLV40-54/48/115	MLV40-54/48/92	MLV40-6/48/115	—
		MLV40-54/40b/49/115	MLV40-54/49/92	MLV40-6/40b/49/115	—
OUTPUT: Transistor		/47	2 PNP	2 PNP	2 PNP
		/48	2 NPN	2 NPN	2 NPN
		/49	1 NPN and 1 PNP	1 NPN and 1 PNP	1 NPN and 1 PNP
SUPPLY VOLTAGE		10-30VDC	10-30VDC	10-30VDC	10-30VDC
LED(s)		Yes (1)	Yes (1)	Yes (1)	Yes (1)
CURRENT CONSUMPTION		≤40mA	≤40mA	≤40mA	≤40mA
OPERATING MODE		Light on/dark on	Light on/dark on (D.O. for /49)	Light on/dark on	Light on/dark on
RESPONSE TIME		≤1.0ms	≤1.0ms	≤1.0ms	≤1.0ms
SWITCHING FREQUENCY		500Hz	500Hz	500Hz	500Hz
LIGHT SPOT DIAMETER		≈40mm at a range of 1m	≈40mm at a range of 1m	≈100mm at a range of 2m	≈100mm at a range of 2m
LIGHT BEAM ANGLE		≈4°	≈4°	≈4°	≈4°
LIGHT SOURCE		Visible red LED	Visible red LED	Infrared LED	Infrared LED
AMBIENT LIGHT RESISTANCE		≤80,000 lux	≤80,000 lux	≤80,000 lux	≤80,000 lux
ELECTRICAL CONNECTION		 2-meter cable, PVC covered 4/5-conductor	 Quick disconnect type V1	 2-meter cable, PVC covered 4/5-conductor	 Quick disconnect type V1
ADDITIONAL DATA		<i>See pages 379-382</i>			

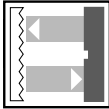

Retro-Reflective Mode

Sensing Characteristics

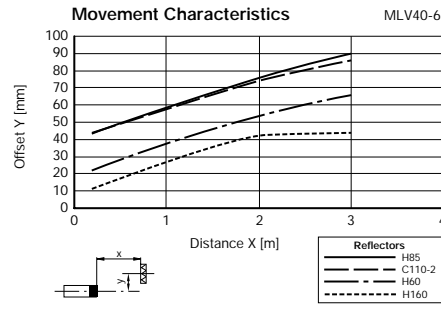
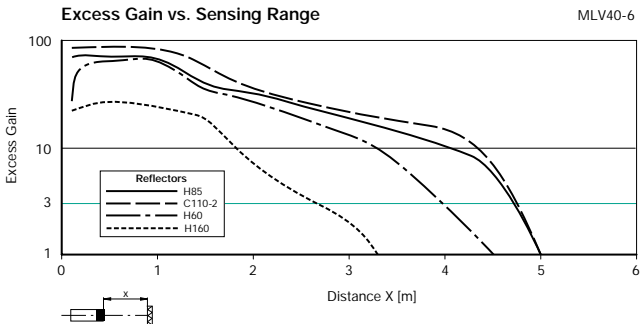
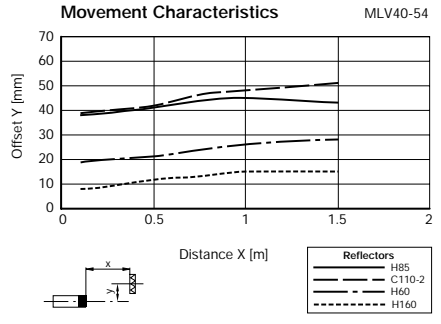
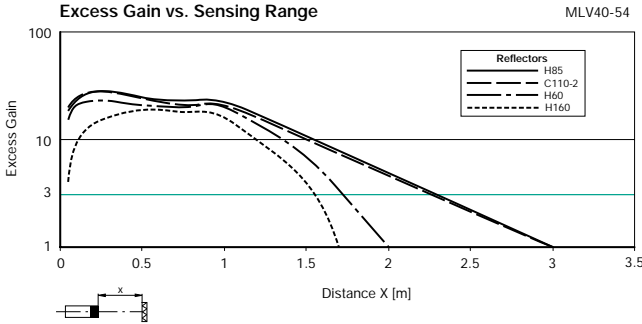



Photoelectric MLV40 Series Miniature Style

Photoelectric Sensors



Retro-Reflective Mode for Clear Object Detection

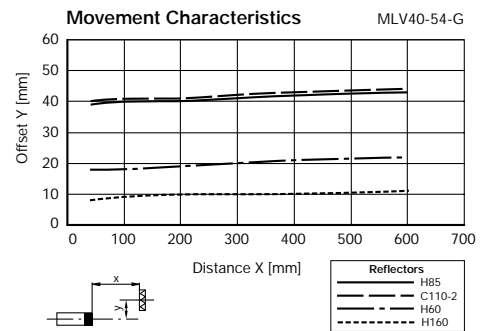
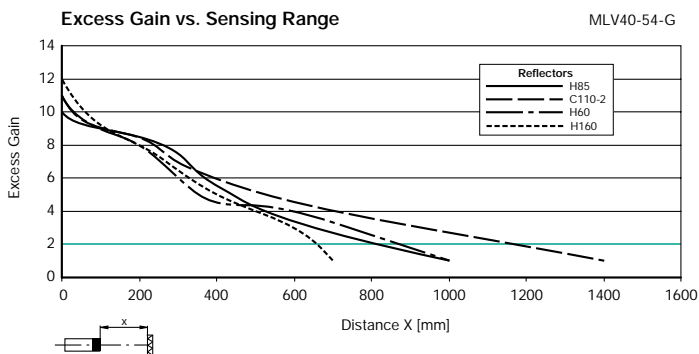

Specifications		
SENSING RANGE	0-400mm	0-400mm
SENSITIVITY ADJUSTMENT	Yes (0-400mm)	Yes (0-400mm)
REFLECTOR DISTANCE	0-400mm	0-400mm
POLARIZED FILTER	Yes	Yes
MODEL NUMBER(S)	MLV40-54-G/40a/47/115	MLV40-54-G/40a/47/92
	MLV40-54-G/40a/49/115	—
OUTPUT: Transistor	/47	2 PNP
	/49	1 NPN and 1 PNP
SUPPLY VOLTAGE	10-30VDC	10-30VDC
LED(s)	Yes (2)	Yes (2)
CURRENT CONSUMPTION	≤40mA	≤40mA
OPERATING MODE	Light on/dark on	Light on/dark on
RESPONSE TIME	≤1.0ms	≤1.0ms
SWITCHING FREQUENCY	500Hz	500Hz
LIGHT SPOT DIAMETER	≈20mm at a range of 400mm	≈20mm at a range of 400mm
LIGHT BEAM ANGLE	≈3°	≈3°
LIGHT SOURCE	Visible red LED	Visible red LED
AMBIENT LIGHT RESISTANCE	≤75,000 lux	≤75,000 lux
ELECTRICAL CONNECTION	 2-meter cable, PVC covered 4-conductor	 Quick disconnect type V1
ADDITIONAL DATA	<i>See pages 379-382</i>	

Sensing Characteristics

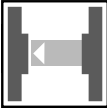



Thru-Beam Mode

Specifications		0-5m	0-5m
SENSING RANGE		0-5m	0-5m
SENSITIVITY ADJUSTMENT		No	No
MODEL NUMBER(S)		M40/MV40-1365/47/115	M40/MV40-1365/47/92
		M40/MV40-1365/48/115	M40/MV40-1365/48/92
		M40/MV40-1365/49/115	—
OUTPUT: Transistor	/47	2 PNP	2 PNP
	/48	2 NPN	2 NPN
	/49	1 NPN and 1 PNP	—
SUPPLY VOLTAGE		10-30VDC	10-30VDC
LED(s)		Yes (1)	Yes (1)
CURRENT CONSUMPTION		≤35mA transmitter ≤25mA receiver	≤35mA transmitter ≤25mA receiver
OPERATING MODE		Light on/dark on (D.O. for /49)	Light on/dark on
RESPONSE TIME		≤5.0ms	≤5.0ms
SWITCHING FREQUENCY		100Hz	100Hz
LIGHT SPOT DIAMETER		150mm at a range of 5m (18mm min. target diameter)	150mm at a range of 5m (18mm min. target diameter)
LIGHT BEAM ANGLE		≈2°	≈2°
LIGHT SOURCE		Infrared LED	Infrared LED
AMBIENT LIGHT RESISTANCE		≤100,000 lux	≤100,000 lux
ELECTRICAL CONNECTION		 2-meter cable, PVC covered 2/4-conductor	 Quick disconnect type V1
ADDITIONAL DATA		See pages 379-382	

Sensing Characteristics

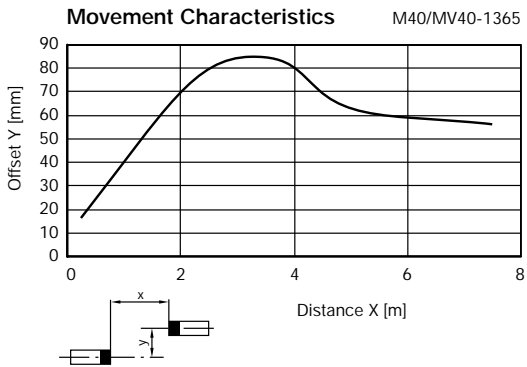
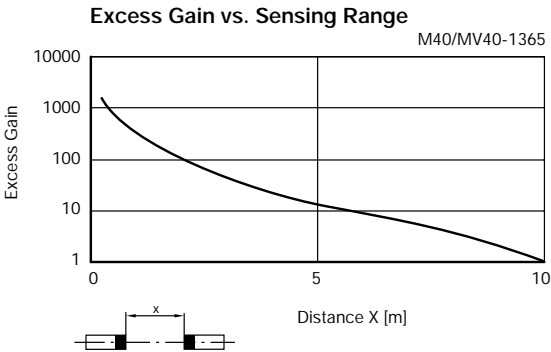



Photoelectric Sensors

Photoelectric MLV40 Series Miniature Style



Fiber Optic Diffused and Thru-Beam Mode

Specifications				
SENSING RANGE		Determined by cable*	Determined by cable*	Determined by cable*
SENSITIVITY ADJUSTMENT		Yes	Yes	Yes
MODEL NUMBER(S)		—	MLV40-LL-IR/47/115	MLV40-LL-IR/47/92
		MLV40-LL-RT/48/115	MLV40-LL-IR/48/115	—
		MLV40-LL-RT/49/115	MLV40-LL-IR/49/115	MLV40-LL-IR/49/92
OUTPUT: Transistor				
/47		—	2 PNP	2 PNP
/48		2 NPN	2 NPN	—
/49		1 NPN and 1 PNP	1 NPN and 1 PNP	1 NPN and 1 PNP
SUPPLY VOLTAGE		10-30VDC	10-30VDC	10-30VDC
LED(s)		Yes (1)	Yes (1)	Yes (1)
CURRENT CONSUMPTION		≤40mA	≤40mA	≤40mA
OPERATING MODE		Determined by cable*	Determined by cable*	Determined by cable*
RESPONSE TIME		≤5.0ms	≤5.0ms	≤5.0ms
SWITCHING FREQUENCY		100Hz	100Hz	100Hz
LIGHT SOURCE		Visible red LED	Infrared LED	Infrared LED
AMBIENT LIGHT RESISTANCE		≤50,000 lux	≤50,000 lux	≤50,000 lux
ELECTRICAL CONNECTION		 2-meter cable, PVC covered 4-conductor	 2-meter cable, PVC covered 4-conductor	 2-meter cable, PVC covered 4-conductor
ADDITIONAL DATA		<i>See pages 379-382</i>		



**See pages 735-764 for glass fiber optic lengths and specifications.*

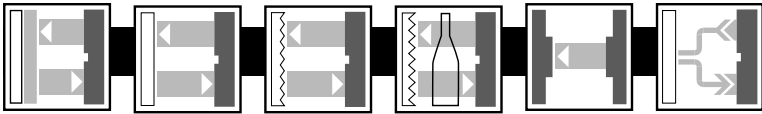

Series Specifications

MLV40 Series Specifications		
LOAD CURRENT	200mA max.	
VOLTAGE DROP	≤1VDC	
SHORT CIRCUIT AND OVERLOAD PROTECTION	Yes	
REVERSE POLARITY PROTECTION	Yes	
VOLTAGE RIPPLE	10%	
ELECTROMAGNETIC COMPATIBILITY COMPLIANCE	NEMA ICS5-2000 See page 6	
PROTECTION (IEC)	IP65	
TEMPERATURE RANGE	WORKING	-4°F to +140°F
	STORAGE	-4°F to +167°F
HOUSING MATERIAL	Aluminum	
LENS	Glass	
WEIGHT	3.5oz (per housing)	
APPROVALS	General Purpose	Yes
	General Purpose	Yes

Photoelectric MLV40 Series Miniature Style

Wiring Diagrams

DC



Cable Connection

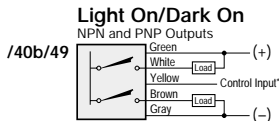
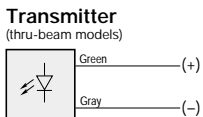
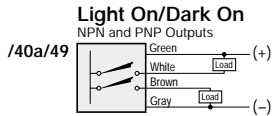
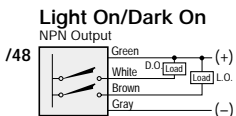
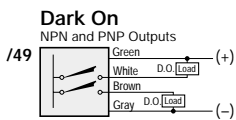
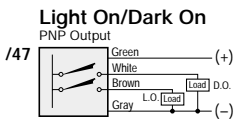

*Control Input:
Dark On mode when disconnected or connected to (-), Light On mode when connected to (+)



Quick Disconnect

Note: Wiring diagrams show quick disconnect pin numbers.

V1 Type

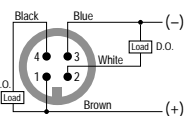
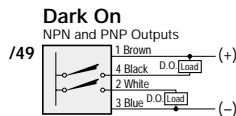
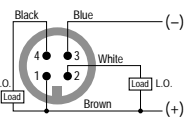
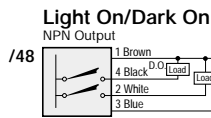
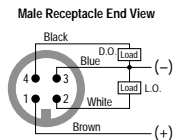
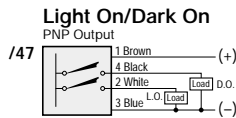

Transmitter

(thru-beam models)

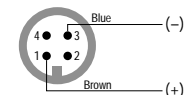

Photoelectric Sensors

Dimensions (mm)

Photoelectric MLV40 Series Miniature Style

MLV40-8-H-.../115

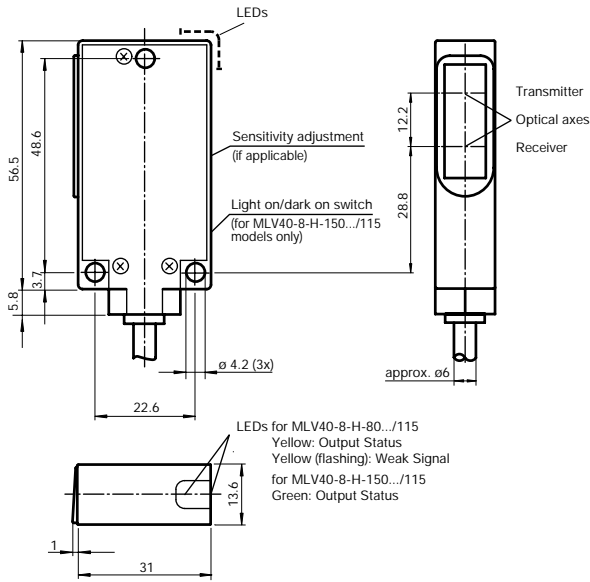

MLV40-8-H-.../92

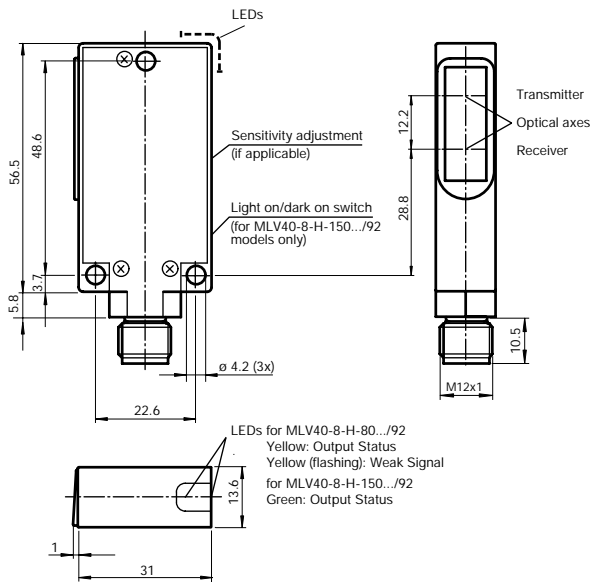

MLV40-8-500.../115, MLV40-54.../115, MLV40-6.../115

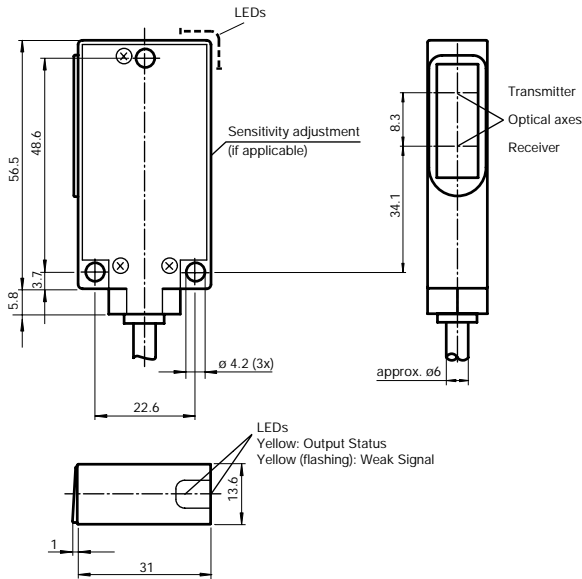

MLV40-8-500.../92, MLV40-54.../92, MLV40-6.../92

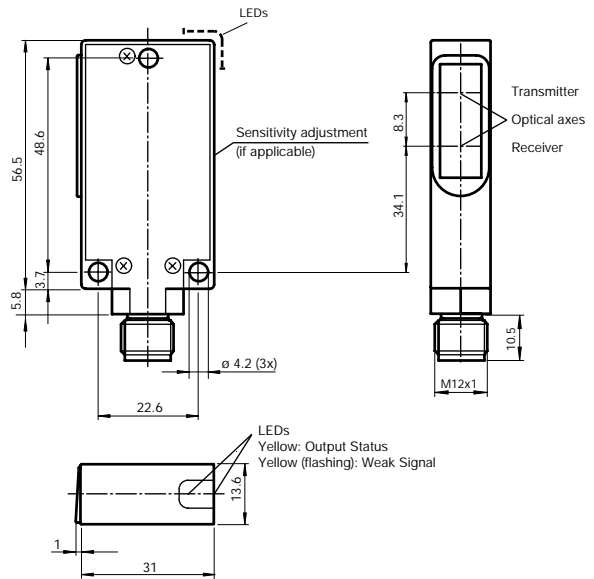

MLV40-54-G.../115

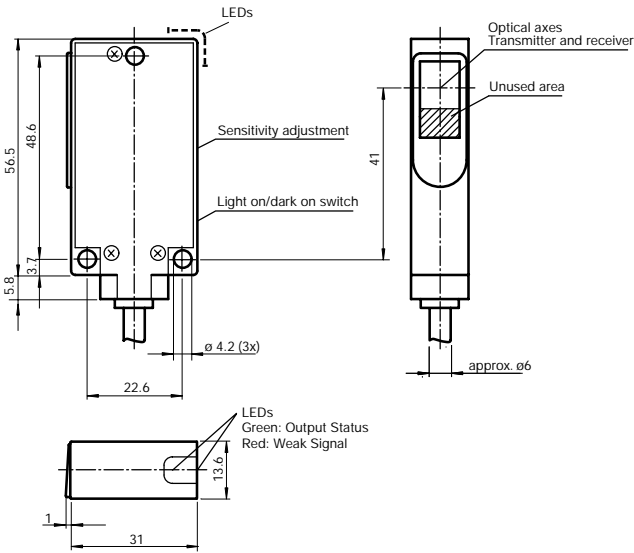

MLV40-54-G.../92

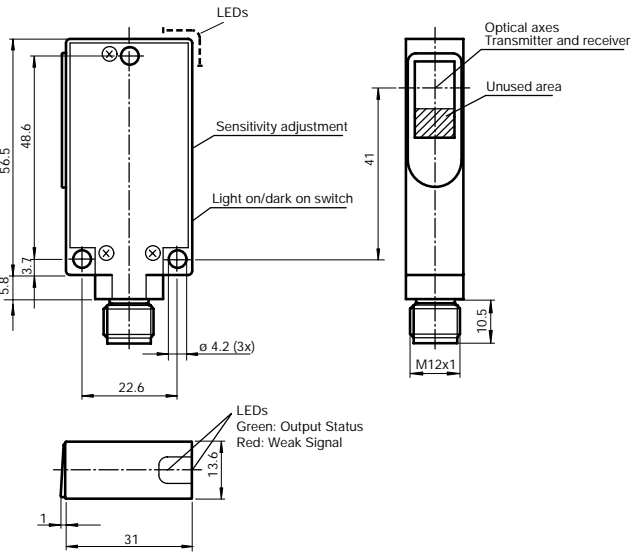

M40/MV40.../115

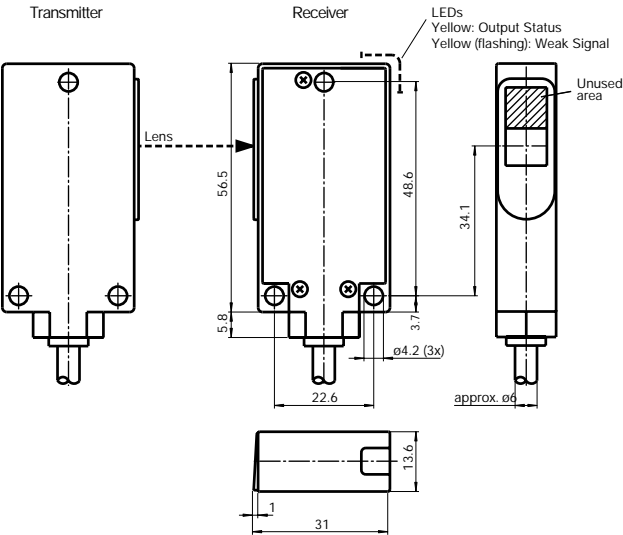

M40/MV40.../92

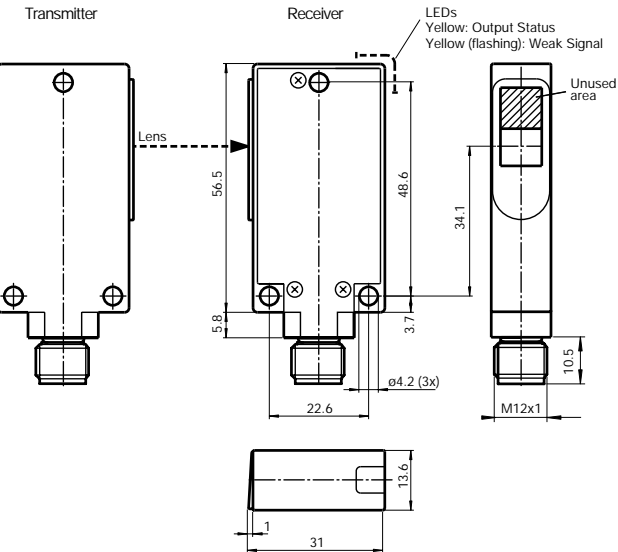

Photoelectric MLV40 Series Miniature Style

Photoelectric Sensors

MLV40-LL../115

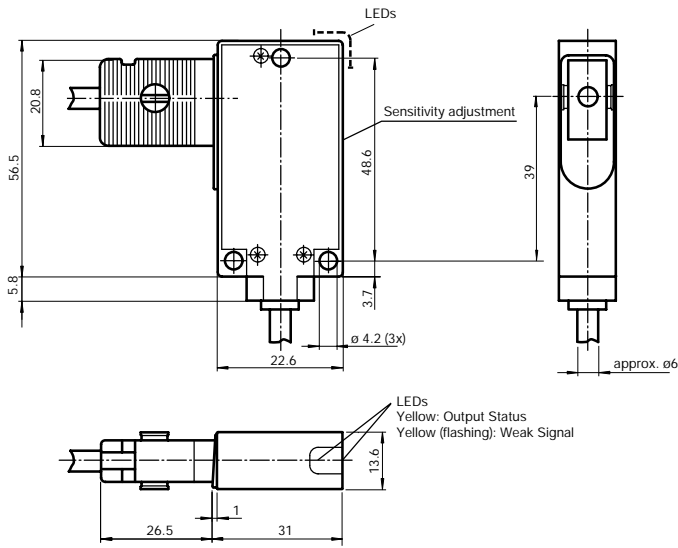

MLV40-LL../92

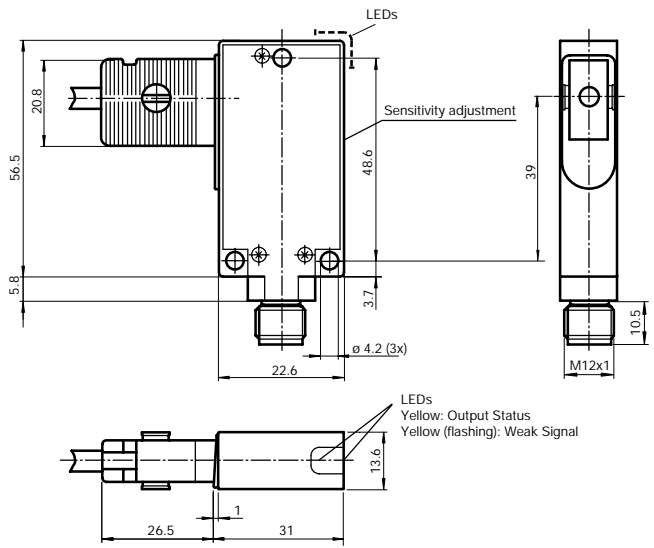

Accessories

(Dimensions in mm)

Mounting Bracket Model OMH-40

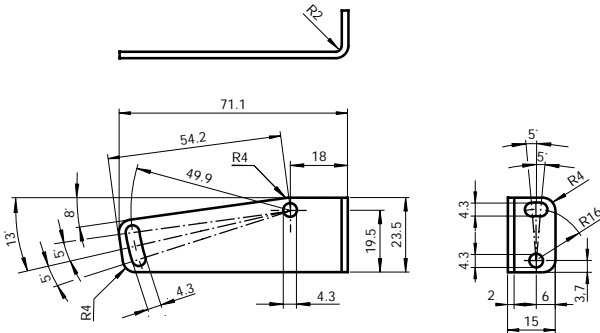

See pages 769-828 for cordsets



See pages 829-840 additional accessories for photoelectric sensors