

M12 Class 1 Laser Emitter

IEC Class 1 Laser for use with Banner modulated receivers



Features and Benefits

- A low-power device emitting a visible red beam (650 nm wavelength).
- Beam is bore-sighted to within 2 milliradians and 0.25 mm of the housing centerline.
- Collimated, apertured beam is 2mm diameter with divergence of less than 1 milliradian.
- Compatible with a variety of Banner modulated photoelectric receivers (see Excess Gain chart, page 3).
- Useful for medium-range sensing, or for sensing very small objects or profiles; excellent mechanical repeatability in position-sensing applications.
- Smooth-barrel aluminum housing is suitable for a precision mount.
- Available with unterminated, 2 m (6.5') cable or 150 mm (6") pigtail, quick-disconnect cable
- Modulated beam (33kHz, 25% duty cycle)
- 57 mm (2.25") long overall
- 10 to 30V dc operation



CAUTION . . .

Never stare directly into the emitter lens. Laser light can damage your eyes.

Avoid placing any mirror-like object in the beam. Never use a mirror as a target. (See Figure 5.)

Models

Models	Range	Cable*	Supply Voltage	Excess Gain	Effective Beam at Receiver	
					Opposed Distance	Beam Width
M126E1LD	Range varies, depending on which receiver is used (see Excess Gain chart, page 3).	2m (6.5') Unterminated	10-30V dc	See chart on page 3.	<u>at 25°C</u>	
M126E1LDQ		150 mm (6") Pigtail with 3-wire Pico-style QD connector			1.5 m (5')	3.5 mm (0.14")
					3 m (10')	5.5 mm (0.2")
					6 m (20')	8.5 mm (0.3")
					15 m (50')	18 mm (0.7")
					30 m (100')	32 mm (1.3")

*9 m (30') cables are available by adding suffix "W/30" to the model number to the cabled version (e.g., **M126E1LD W/30**).

A model with a QD connector requires an accessory mating cable. See page 6.



WARNING . . . Not To Be Used for Personnel Protection

Never use these products as sensing devices for personnel protection. Doing so could lead to serious injury or death.

These sensors do NOT include the self-checking redundant circuitry necessary to allow their use in personnel safety applications. A sensor failure or malfunction can cause either an energized or de-energized sensor output condition. Consult your current Banner Safety Products catalog for safety products which meet OSHA, ANSI and IEC standards for personnel protection.

M12 Class 1 Laser Emitter

M12 Class 1 Laser Emitter Specifications

Supply Voltage and Current	10 to 30V dc (10% maximum ripple) at less than 30 mA
Supply Protection Circuitry	Protected against electrostatic discharge (ESD) and transient voltages; Protected against reverse polarity
Delay at Power-up	Less than 30 milliseconds
Sensing Beam	650 nm visible red laser (temperature coefficient 0.2 nm/°C); Pulse Width: 7µs Rep Rate: 30µs Peak Output Power: 0.36 milliwatts
Beam Diameter at Aperture	Approximately 2 mm (0.08") diameter
Beam Divergence	±0.5 milliradians typical at 25°C; ±1.0 milliradian at operating temperature extremes
Beam Placement	Within 0.25 mm (0.01") and ±2 milliradians of mechanical centerline axis of housing
Laser Control	Apply +10 to 30V dc to black wire to enable beam; Inhibit beam by applying 0V dc or by opening circuit; Enable delay less than 30 milliseconds; Inhibit delay less than 1 millisecond
Indicators	Indicators are visible through rear cover. Green indicates power applied Yellow indicates laser enabled
Construction	12.7 mm (0.50") diameter smooth aluminum barrel; Black hard-coat anodized finish, MIL-A-8625 Type III, Class II
Environmental Rating	NEMA 6; IEC IP67
Connections	PVC-jacketed 3-conductor 2 m (6.5') or 9 m (30') high-flex cable (unterminated); or 150 mm (6") pigtail with 3-wire Pico-style connector
Operating Temperature	Temperature: 0° to 40° C (32° to 104° F); Maximum relative humidity: 90% at 40° C (non-condensing)
Laser Classification	Class 1 laser product; complies with 21 CFR 1040.10, EN 60825-1:2001 except for deviations pursuant to laser notice No. 50, dated 7-26-01
Certifications	

M12 Class 1 Laser Emitter

M12 Dimensions

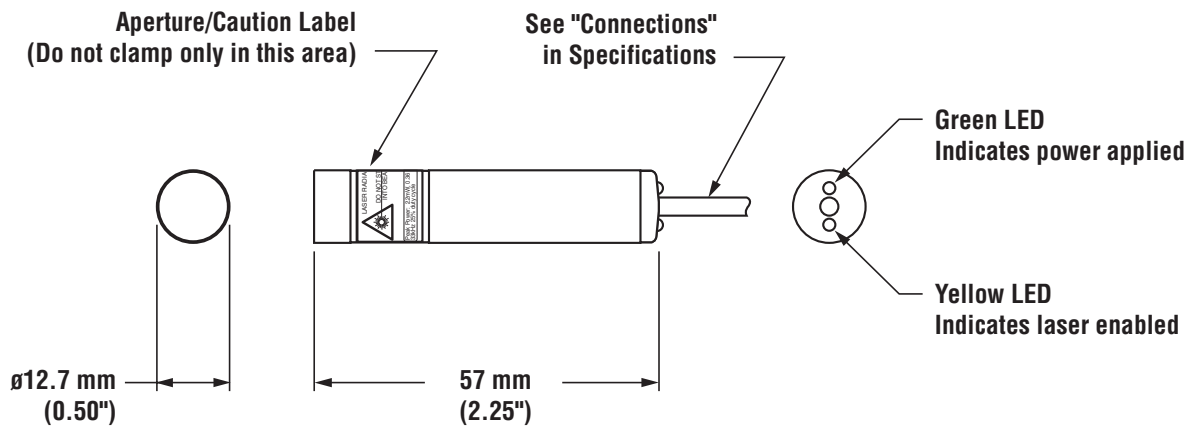

Excess Gain

Excess Gain of the M12 emitter is dependent on the particular receiver used. Following is a comparison of the excess gain for various recommended receivers at 15 m (50').

Receiver	Excess Gain at 15 m (50')	Receiver	Excess Gain at 15 m (50')
MULTI-BEAM		MINI-BEAM	
SBRX1	1,900	SM31R	250
SBR1	1,900	SM31RL	1,700
SBRXD1	1,900	SM31RMHS	180
SBRD1	1,900	SM31RLMHS	1,100
MAXI-BEAM		ECONO-BEAM	
RSBR	1,400	SE61R	60
RSBRSR	150	SE61RMHS	50
VALU-BEAM		Others	
SMW95R	3,400	SM51RB	120
SMI91RQD	1,800	Q23SN6R	40
EZ-BEAM		Q10AN6R	25
T18SN6R	750	Q45BB6R	900
T30SN6R	750		
S12SN6R	750		

For information on compatibility of the M12 emitter with other Banner photoelectric receivers contact the factory Applications Group at the address or numbers listed on the back cover.

M12 Class 1 Laser Emitter

Mounting

Mounting suggestions:

- To take advantage of the bore-sight beam placement offered by the M12 laser emitter, use a two-part clamp mount or a mounting block with a precision-drilled hole. Allow minimum clearance for the 12.7 mm (0.50") diameter housing, max. dia. 12.83 mm (0.505").
- Clamp on both sides of the label. Do not clamp only on the labeled area. Use only plastic-tipped screws or set screws – not metal – to avoid compression of the housing.

Mounting bracket assembly model SMB46X3 is recommended for use with the M12 (see Figure 1 and ordering information on page 7). It consists of:

- A black-anodized aluminum block with holes drilled for mounting in any of 3 directions and plastic set screws, and
- An adjustable stainless steel bracket with 3 spring-loaded screws (2 of which are used for precise alignment).

The mounting block may be ordered separately, (model SMB127; see pages 6 and 7).

To mount the M12, insert the laser emitter into the black mounting block, through any of the three holes. Check to be sure that the label area of the emitter is not aligned with a set screw, then tighten the set screws (using the supplied 3/64" Allen wrench) so the emitter is held snugly in place. Then mount the block to the adjustable baseplate (or to your own bracket). Mount the bracket base using your own M5 or #10 screws or bolts, and then check for alignment (see page 5). Tighten or loosen one or two of the precision alignment screws (using the supplied 2 mm Allen wrench) until the laser is accurately aligned.

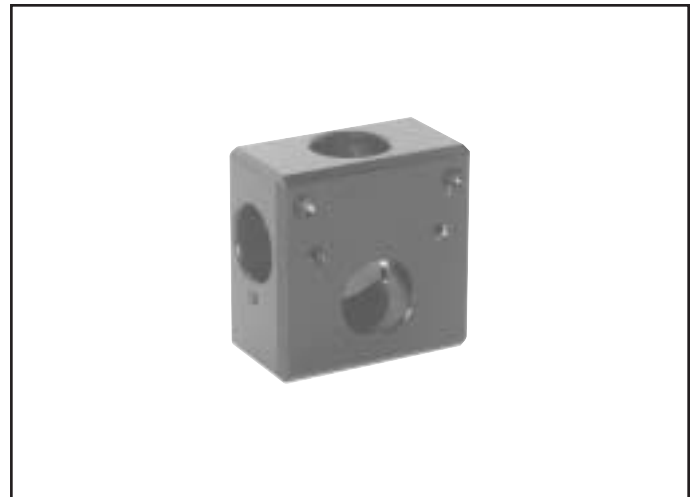

Figure 1. Model SMB127 mounting block

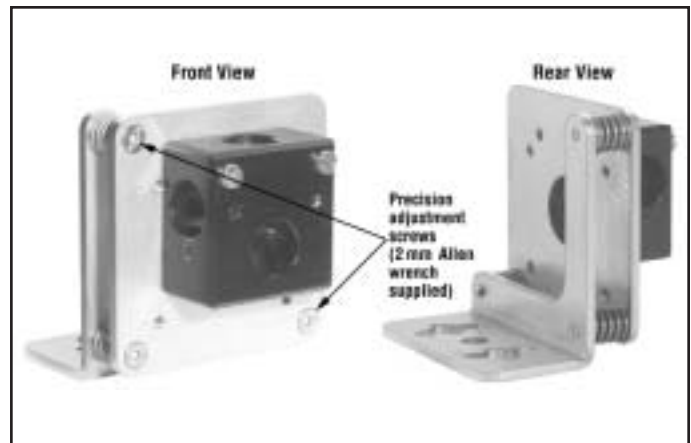

Figure 1a. Mounting bracket model SMB46X3, front and rear views



Figure 2. Three possible M12 orientations

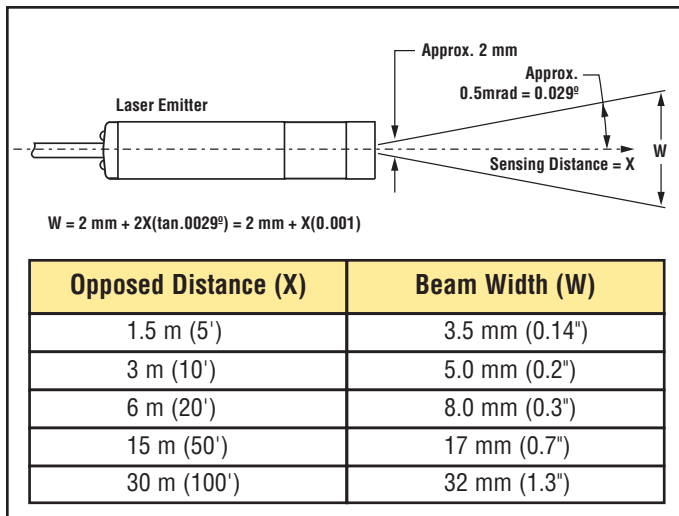

Figure 3. M12 laser emitter beam divergence at 25°C (beam size vs. distance)

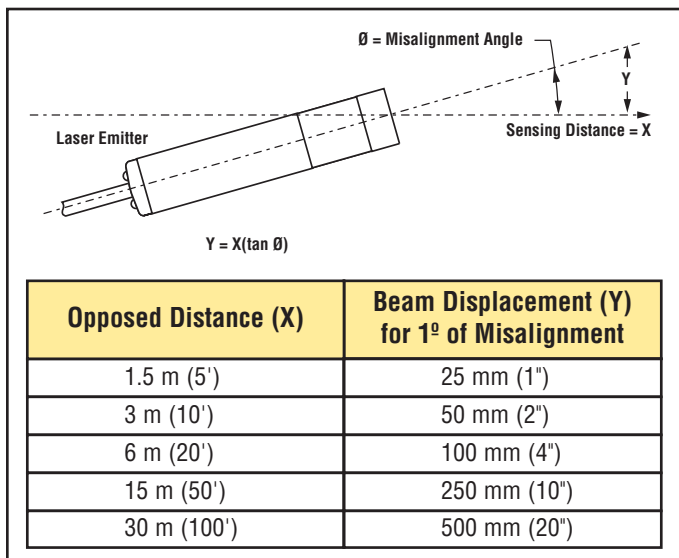

Figure 4. Beam displacement per degree of misalignment

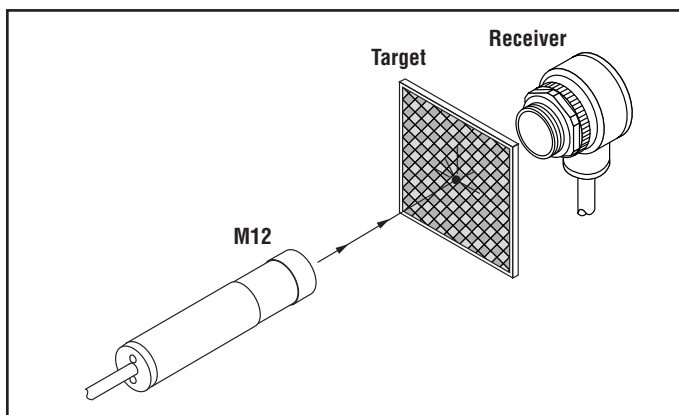

Figure 5. At long distances, use retroreflective tape to locate the beam at the receiver location. Never use a mirror as an alignment target.

Alignment

Conventional modulated infrared LED photoelectric emitters are designed with beam divergence angles of several degrees. As a result, most emitters are easily aligned to their receivers by simple line-of-sight methods.

In sharp contrast to conventional photoelectric emitters, M12 laser emitters have a beam divergence of only 0.03° (0.5 milliradians) at 25° C (77°F) ambient temperature (see Figure 3). This translates, for example, to a beam diameter of only 0.3" at a distance of 20'. Consequently, there is very little forgiveness for angular misalignment.

The beam size listed in Figure 3 is also the effective beam size at the receiver. The effective beam is equal to the minimum opaque object profile required to block the light beam. The beam size at the emitter is 2 mm (.08") diameter.

The effect of angular misalignment is dramatic (see Figure 4). The wide beam angles offered by conventional photoelectric emitters allow several degrees of misalignment between the optical axes of the emitter and receiver. This is not true for laser emitters which require their beam center to directly strike the receiver lens. Figure 4 shows how far the laser beam will miss the center of the receiver lens for each degree of angular misalignment (in any plane). Note that even at only a 5' range, one degree of misalignment will cause the laser beam to miss the lens of most receivers.

Alignment Tip: The visible red beam of the laser emitter is easily seen in subdued lighting. At opposed distances of up to 10', attach a sheet of white paper directly in front of the receiver lens. Mark the location of the lens center on the paper. This mark is used as an aiming target. Sight along the beam from directly behind the laser emitter. Adjust the emitter mounting until the red image (the dot of red light) is centered exactly on the mark. Remove the paper and check the response of the receiver.

For longer distances (up to 25'), replace the white paper with a 4" x 4" square of high-grade retroreflective tape (Banner model BRT-THG-4X4-5 or equivalent; see Figure 5). For greater distances, use a larger sheet of retroreflective material (see page 7).

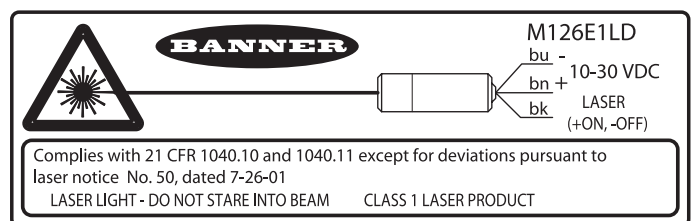

M12 Class 1 Laser Emitter

Hookups

M126E1LD Laser Diode Emitter
Unterminated Cable

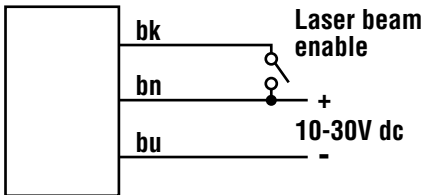

M126E1LDQ Laser Diode Emitter
3-pin Pico-style Connector

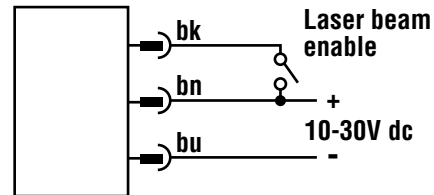

Mounting Bracket Dimensions

SMB46X3 Bracket Assembly

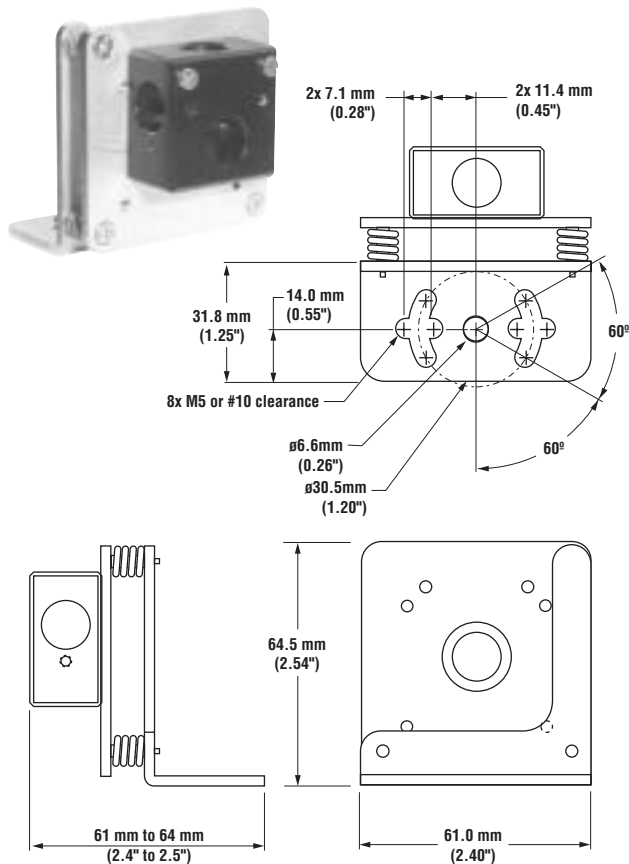

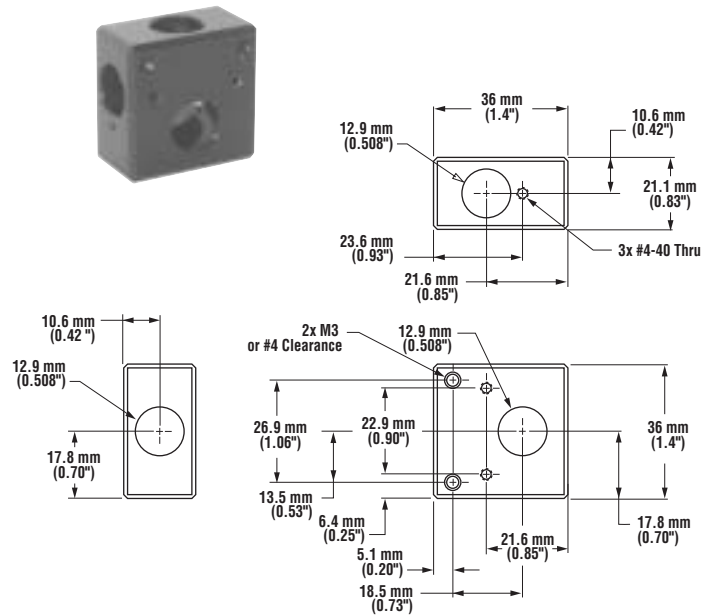

SMB127 Mounting Block



M12 Class 1 Laser Emitter

Accessories

Mounting Brackets

Model	Description	
SMB46X3	Assembly with mounting block and adjustable bracket Comes with: 2mm Shortarm hex key 3/64" Shortarm hex key 4 Set screws	
SMB127	Mounting block only Comes with: 3/64" Shortarm hex key 4 Set screws	

Retroreflective Tape

Model	Reflectivity Factor	Maximum Temperature	Size	Unit	
BRT-THG-4X4-5	0.7	60°C (140°F)	100 x 100 mm (4" x 4")	Package of 5	
BRT-THG-8.5X11-2	0.7	60°C (140°F)	216 x 280 mm (8.5" x 11")	Package of 2	
BRT-THG-18X36	0.7	60°C (140°F)	457 x 914 mm (18" x 36")	Single Sheet	

Pico-Style Quick-Disconnect Cables

Cable: PUR jacket, polyurethane connector body, POM snap-lock coupling

Conductors: 26 or 24 AWG high-flex stranded, gold-plated contacts

Temperature: -40° to +90°C (-40° to +194°F)

Voltage Rating: 30V ac/36V dc

Environmental Rating: None

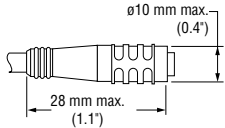
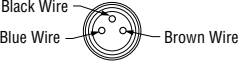

Model	Style	Length	Dimensions	Pin-out
PKG3-2	3-Pin Straight	2 m (6.5')	 <p>ø10 mm max. (0.4") 28 mm max. (1.1")</p>	 <p>Black Wire Blue Wire Brown Wire</p>

M12 Class 1 Laser Emitter



WARRANTY: Banner Engineering Corp. warrants its products to be free from defects for one year. Banner Engineering Corp. will repair or replace, free of charge, any product of its manufacture found to be defective at the time it is returned to the factory during the warranty period. This warranty does not cover damage or liability for the improper application of Banner products. This warranty is in lieu of any other warranty either expressed or implied.

P/N 53808 rev. B

Banner Engineering Corp., 9714 Tenth Ave. No., Minneapolis, MN 55441 • Phone: 763.544.3164 • www.bannerengineering.com • E-mail: sensors@baneng.com