



WORLD-BEAM® QS30 Series

Polarized Retroreflective Laser Sensors

Features



- Visible class 1 laser with small, effective beam size
- Excellent optical performance throughout sensing range, even close up
- Easy push-button SET options: Maximum Excess Gain or Low-Contrast SET, depending on model, plus Manual Adjust
- Easy-to-read operating status indicators, with 8-segment bargraph display
- Bipolar discrete outputs, PNP and NPN
- Selectable 30 millisecond OFF-delay
- Models available with 2 m or 9 m (6.5' or 30') cable or integral quick-disconnect
- Tough ABS housing rated IEC IP67; NEMA 6
- Compact housing, mounting versatility – popular 30 mm threaded nose or side-mount

Excellent for applications where high sensing power and small beam size are important. Operates over sensing ranges typically accomplished only by conventional opposed-mode photoelectrics; uses a special filter to polarize the emitted light, filtering out unwanted reflections from shiny objects.



Visible Red, Class 1 laser; 650 nm

Models

Model	Range and Use	Spot Size at Focus	Cable*	Supply	Output Type	Excess Gain	
						With Supplied Target BRT-36X40BM	With Supplied Target BRT-TVHG-2X2
QS30LLP	0.2 to 18 m (0.67' to 60') Maximum Excess Gain SET for Long-Range Applications	Approx. 4 mm at 10 m (0.16" at 33')	2 m (6.5') 5-wire Cable	10 to 30V dc	Bipolar NPN/PNP		
QS30LLPQ			Integral 5-pin Euro-style QD				
QS30LLPC	0.2 to 18 m (0.67' to 60') Low-Contrast SET for Small Object Detection		2 m (6.5') 5-wire Cable				
QS30LLPCQ			Integral 5-pin Euro-style QD				

*9 m (30') cables are available by adding suffix "W/30" to the model number of any cabled sensor (e.g., QS30LLP W/30). A model with a QD connector requires a mating cable (see page 10).



WARNING . . . Not To Be Used for Personnel Protection

Never use this product as a sensing device for personnel protection. Doing so could lead to serious injury or death.

This product does NOT include the self-checking redundant circuitry necessary to allow its use in personnel safety applications. A sensor failure or malfunction can cause either an energized or de-energized sensor output condition. Consult your current Banner Safety Products catalog for safety products which meet OSHA, ANSI and IEC standards for personnel protection.

WORLD-BEAM® QS30 Series – Polarized Retroreflective Laser Sensors

Overview

QS30LLP and QS30LLPC Series sensors are easy-to-use, high-performance laser sensors whose many configuration options make them suitable for demanding applications. Each sensor features two identically configured outputs, one each NPN and PNP.

The compact housing has a large, easy-to-see bargraph display plus bright LEDs for easy configuration and status monitoring during operation. The sensor can be side-mounted, using integral mounting holes, or front-mounted, via the 30 mm threaded barrel.

Model QS30LLP(Q) is configured using the Maximum Excess Gain SET procedure. It is useful for long-range applications and high variations in contrast, such as beam-break applications where the target objects are larger than the beam. See page 4 for more information.

Model QS30LLPC(Q) is configured using the Low-Contrast SET procedure. It is useful for small object detection and other applications with small variations in contrast, such as yarn- or thread-break applications. See page 5 for more information.

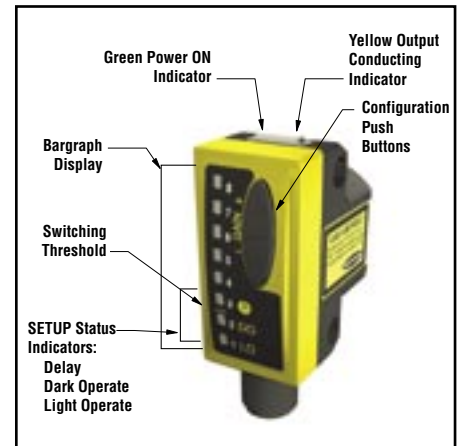

Figure 1. Model QS30LLP features

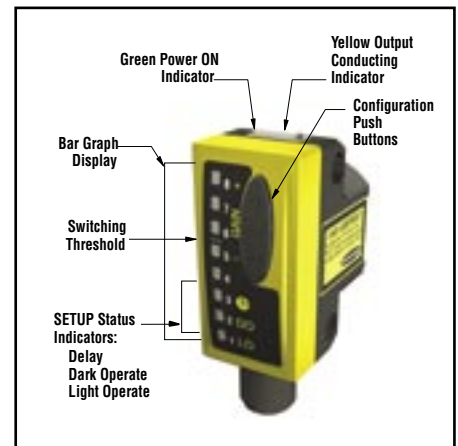

Figure 2. Model QS30LLPC features

Sensor Configuration

Sensor configuration is accomplished using the SET and SETUP modes. After SET mode has defined the sensing parameters, SETUP mode may be used to add an OFF-delay or change the light/dark operate status. Manual Adjust may be used to fine-tune the thresholds. Two push buttons, “+” and “-”, may be used to access and set sensing parameters. In addition, the remote wire also may be used for some procedures (see below).

Remote Configuration

The Remote Configuration function may be used to set the sensor threshold remotely or to disable the push buttons for security. Connect the gray wire of the sensor to ground (0V dc), with a remote programming switch connected between them. Pulse the remote line according to the diagrams in the programming procedures. The length of the individual programming pulses is equal to the value T:

$$0.04 \text{ seconds} \leq T \leq 0.8 \text{ seconds}$$

Push Button Disable

In addition to its programming function, Remote Programming may be used to disable the push buttons for security. Disabling the push buttons prevents undesired tampering with the programming settings. Connect the gray wire of the sensor as described on above, and four-pulse to either enable or disable the push buttons:



WORLD-BEAM® QS30 Series – Polarized Retroreflective Laser Sensors

Maximum Excess Gain SET – Model QS30LLP

- Sets the sensor for maximum excess gain without allowing false proxing. Provides maximum contrast between any reflector and a blocked condition and is stable even in dirty environments.
- Useful for long-range applications and high variations in contrast, such as beam-break applications where the target objects are larger than the beam.

Sensor can be aimed at an object or the reflector during SET process to obtain the same result. All conditions darker than the switchpoint condition result in ON output (Dark Operate). Output ON and OFF conditions can be reversed by changing Light/Dark Operate in SETUP mode (factory setting: Dark Operate).

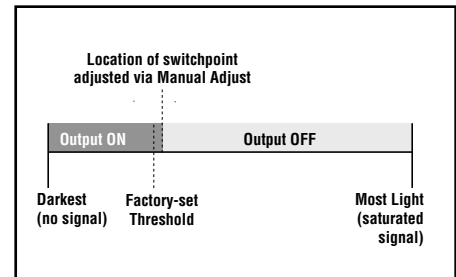

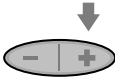

Figure 3. Maximum Excess Gain SET (Dark Operate shown)

Manual Adjust – Maximum Excess Gain SET

During RUN mode, adjusts switchpoint up or down via “+” or “-” push buttons.

- Each push button “click” adjusts the switchpoint up by approximately 0.5X excess gain or down by the same increments.
- The lighted bargraph LEDs move to reflect the increase or decrease of excess gain relative to the switchpoint.
- LEDs #7 and 8 flash when maximum gain is achieved; LEDs #1 and 2 flash when minimum gain is achieved.

When the received signal is at any level greater than 6X excess gain, the first “-” (minus) click to reduce excess gain reduces it to the 6X level. Subsequent “-” clicks result in decreased values as shown in the Specifications table on page 8 (approximately 2 clicks per LED change). To return to maximum excess gain, either press “+” repeatedly until LEDs #7 and 8 flash, or hold the “+” button for longer than 2 seconds. For example, in an application that results in 20X excess gain, pressing “-” once lowers the gain to 6X, exhibited by LED #8 ON. Pressing it twice more results in approximately 5X excess gain, exhibited by LED #7 ON. Holding the “+” button for 2 seconds results in a return to maximum gain (20X), exhibited by LEDs #7 and 8 flashing.

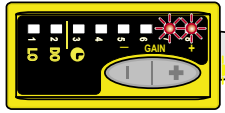
	Push Button	Remote 0.04 seconds ≤ T ≤ 0.8 seconds	Indicators
Set Switchpoint	<ul style="list-style-type: none"> • Press and hold “+” > 2 seconds 	<ul style="list-style-type: none"> • Single-pulse remote line. 	<p>Green Power LED: OFF Yellow Output LED: ON Bargraph: #7 & 8 flashing</p>  <ul style="list-style-type: none"> • Sensor returns to RUN mode with new settings • Use Manual Adjust to increase or decrease sensor excess gain

WORLD-BEAM® QS30 Series – Polarized Retroreflective Laser Sensors

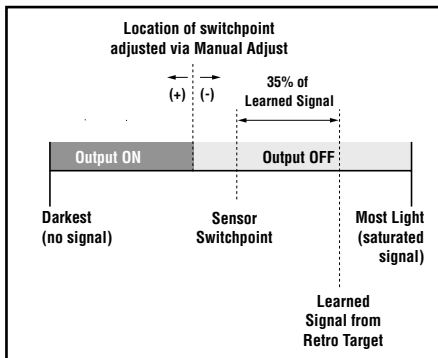

Figure 4. Low-contrast SET (Dark Operate shown)

Low-Contrast SET – Model QS30LLPC



- Sets a switchpoint at 35 percent below the signal from the retroreflector.
- Useful for small object detection and other applications with small variations in contrast, such as yarn- or thread-break applications.
- Sensor must be aimed at the reflector during the SET process. All conditions darker than the switchpoint condition result in ON output (Dark Operate). Output ON and OFF conditions can be reversed by changing Light/Dark Operate in SETUP mode (factory setting: Dark Operate).

Manual Adjust – Low-Contrast SET

During RUN mode, adjusts switchpoint up or down via “+” or “-” push buttons.

- Each push button “click” adjusts the switchpoint up by 5 percent of the signal from the reflector or down by the same increments.
- The lighted bargraph LEDs move to reflect the increase or decrease in excess gain.
- LEDs #7 and 8 flash when maximum gain is achieved; LEDs #1 and 2 flash when minimum gain is achieved.

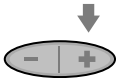
If the target object does not cause the output to change state, press the “-” button to decrease the gain, making the sensor more sensitive to small signal changes.

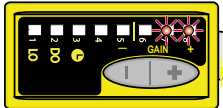
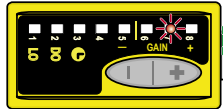
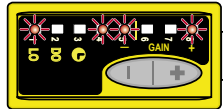
	Push Buttons	Remote 0.04 seconds ≤ T ≤ 0.8 seconds	Indicators
Set Switchpoint	<ul style="list-style-type: none"> • Align sensor to reflector • Press and hold “+” > 2 seconds 	<ul style="list-style-type: none"> • Align sensor to reflector • Single-pulse remote line 	<p>Green Power LED: OFF Yellow Output LED: ON (Push Button) Output LED: OFF (Remote) Bargraph: #7 & 8 flashing</p> 
Sensor Feedback			<p>Switchpoint Accepted</p> <p>Green Power LED: ON Bargraph: Appropriate LED ON</p> <ul style="list-style-type: none"> • Sensor returns to RUN mode with new settings • Use Manual Adjust to increase or decrease sensor sensitivity 
			<p>Switchpoint Unacceptable</p> <p>Green Power LED: ON Bargraph: Appropriate LED ON</p> <ul style="list-style-type: none"> • Sensor returns to RUN mode with new settings • Use Manual Adjust to increase or decrease sensor sensitivity 

WORLD-BEAM® QS30 Series – Polarized Retroreflective Laser Sensors

SETUP Mode

SETUP mode is accomplished via the sensor's two push buttons. It is used to change sensor output response for:

- Light or Dark Operate
- 30-millisecond pulse stretcher (OFF-delay), if required.

The status LEDs, active only during SETUP mode, indicate the output response configuration when the sensor will be in RUN mode.

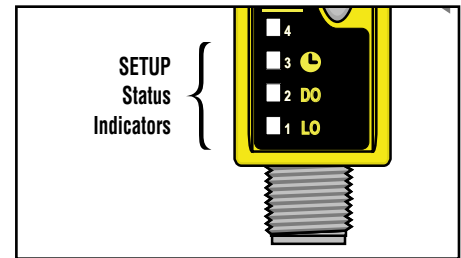

Figure 5. SETUP mode

	Push Button $0.04 \text{ seconds} \leq T \leq 0.8 \text{ seconds}$	Result
Access SETUP Mode	<ul style="list-style-type: none"> • Press and hold both push buttons > 2 seconds 	<ul style="list-style-type: none"> • Green Power LED turns OFF
Select SETUP Options	<ul style="list-style-type: none"> • Click either push button to toggle through the four possible setting combinations 	<div style="display: flex; justify-content: space-around; text-align: center;"> <div>DO, No Delay</div> <div>DO, 30 ms Delay</div> <div>LO, 30 ms Delay</div> <div>LO, No Delay</div> </div>
Return to RUN Mode	<ul style="list-style-type: none"> • Press and hold both push buttons > 2 seconds 	<ul style="list-style-type: none"> • Green Power LED turns ON

WORLD-BEAM® QS30 Series – Polarized Retroreflective Laser Sensors

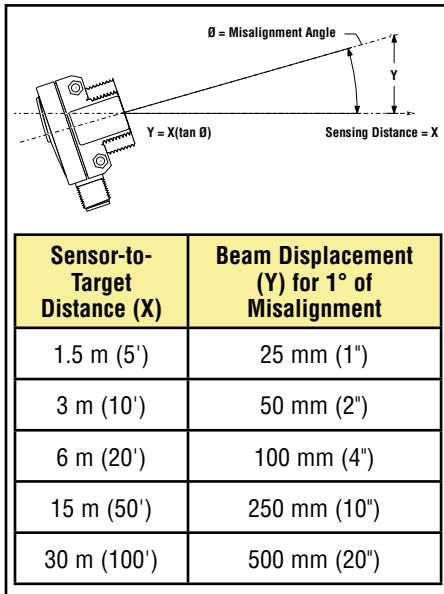



Figure 6. Beam displacement per degree of misalignment

Sensor-to-Object Distance (X)	Minimum Object Detection Size
0.3 m (1')	2.5 mm (0.10")
1.5 m (5')	5.0 mm (0.20")
3 m (10')	7.0 mm (0.28")
18 m (59')	13 mm (0.52")

Figure 7. Minimum object detection size vs. distance from sensor, model QS30LLP(Q)



CAUTION ...
Never stare directly into the sensor lens. Laser light can damage your eyes. Avoid placing any mirror-like object in the beam. Never use a mirror as a retroreflective target.

Installation Notes

Conventional retroreflective photoelectric sensors are extremely easy to align. Beam angles are wide, and retro targets are forgiving to the light beam's angle of incidence. The beam of this laser sensor is very narrow, compared with the beam of most retro sensors. As Figure 6 indicates, the effect of angular misalignment can be dramatic. Alignment is critical because the beam may miss the retroreflective target unless the target is large.

For example, with one BRT-36X40BM mounted at a distance of 6 m (20') from the sensor, one degree of angular misalignment will cause the center of the laser beam to miss the center of the target by 100 mm (4").

Alignment Tip

When using a small retroreflective target at medium or long range, it is often useful to temporarily attach (or suspend) a strip of retroreflective tape (e.g., BRT-TVHG-2X2) along a line that intersects the actual target. The visible red laser beam is easily seen in normal room lighting on such tape. Sight along the beam toward the target (from behind the sensor). Move the sensor to scan the laser beam back and forth across the retro tape strip. Use the tape strip to guide the beam onto the target.

Consider using sensor mounting bracket model SMB30SC (see page 11). This swivel bracket can simplify multiple-axis alignment. Alignment is complete when the visible image is centered on the retro target. The perpendicularity of the laser beam to the face of the retro target is forgiving, just as it is with a conventional retroreflective sensor.

Effective Beam Size

Unlike conventional retroreflective sensors, the retroreflective laser has the ability to sense relatively small profiles. Figure 7 indicates the diameter of the smallest opaque rod which will reliably break the laser beam at several sensor-to-object distances using sensor model QS30LLP(Q). These minimum object sizes were measured with the sensor aligned to a BRT-36X40 reflector and the gain set to maximum using the Max Excess Gain SET. This sensor is typically recommended for long-range applications of relatively small targets that will completely break the beam.

Smaller objects can be detected by using model QS30LLPC(Q), adjusting the sensor gain down using the Manual Adjust, or performing a Low-Contrast SET of the reflector. Objects as small as 2.0 mm can be reliably detected after performing the Low-Contrast SET at ranges up to 6 m (18'). This sensor is typically recommended for shorter-range applications detecting very small targets that may break only a portion of the beam.



Note that the shape of the beam is elliptical. The minimum object sizes listed assume passage of the rod across the major diameter of the ellipse (worst case). It may be possible to detect objects smaller than the sizes listed if the direction in which the objects pass through the beam can be controlled.

Retroreflector Recommendations

- BRT-36X40BM recommended for beam-block applications up to 18 m range.
- BRT-TVHG-2X2 recommended for applications up to 2 m range. (This retroreflector is an adhesive-backed sealed tape with micro-prism geometry.)

WORLD-BEAM® QS30 Series – Polarized Retroreflective Laser Sensors

Specifications

Supply Beam	650 nm visible red																			
Beam Size at Aperture	Approx. 3 mm																			
Laser Classification	Class 1																			
Supply Voltage	10 to 30V dc (10% max. ripple @ 10% duty cycle) @ 35 mA max current, exclusive of load																			
Supply Protection Circuitry	Protected against reverse polarity, over voltage, and transient voltages																			
Delay at Power-Up	1 second max.; outputs do not conduct during this time																			
Output Configuration	Bipolar: 1 current sourcing (PNP) and 1 current sinking (NPN)																			
Output Rating	150 mA maximum load OFF-state leakage current: < 10 µA at 30V dc ON-state saturation voltage: NPN: < 1.0V @ 150 mA load PNP: < 2.0V @ 150 mA load																			
Output Protection	Protected against output short-circuit, continuous overload, transient over-voltages, and false pulse on power-up																			
Output Response Time	500 microseconds																			
Repeatability	70 microseconds																			
Adjustments	<ul style="list-style-type: none"> 2 push buttons and remote wire • Easy push-button configuration • Manually adjust (+/-) thresholds (push buttons only) • LO/DO and OFF-delay configuration options • Push-button lockout (from remote wire only) 	Factory Defaults: <ul style="list-style-type: none"> • No Delay • Dark Operate • Push buttons enabled 																		
Indicators	<p>Green LED: Power ON Yellow LED: Output conducting 8-Segment Red Bargraph</p> <p>SETUP mode: LED 3  : Flashes Red when delay is selected LED 2 (DO): Flashes Red when Dark Operate is selected LED 1 (LO): Flashes Red when Light Operate is selected</p> <p>RUN mode: Signal strength (excess gain), relative to switchpoint</p> <table border="0" style="width: 100%; border-collapse: collapse;"> <thead> <tr> <th style="text-align: left; width: 50%;">Model QS30LLP</th> <th style="text-align: left; width: 50%;">Model QS30LLPC</th> </tr> </thead> <tbody> <tr><td>LED 8: >6X</td><td>LED 8: >2X</td></tr> <tr><td>LED 7: 5-6X</td><td>LED 7: 1.5-2X</td></tr> <tr><td>LED 6: 4-5X</td><td>LED 6: 1-1.5X</td></tr> <tr><td>LED 5: 3-4X</td><td>LED 5: 0.8X</td></tr> <tr><td>LED 4: 2-3X</td><td>LED 4: 0.6X</td></tr> <tr><td>LED 3: 1-2X</td><td>LED 3: 0.4X</td></tr> <tr><td>LED 2: 0.5-1X</td><td>LED 2: 0.2X</td></tr> <tr><td>LED 1: 0-0.5X</td><td>LED 1: 0X</td></tr> </tbody> </table> <p>Sensor calibration failure: Alternating even-numbered and odd-numbered LEDs flash</p>		Model QS30LLP	Model QS30LLPC	LED 8: >6X	LED 8: >2X	LED 7: 5-6X	LED 7: 1.5-2X	LED 6: 4-5X	LED 6: 1-1.5X	LED 5: 3-4X	LED 5: 0.8X	LED 4: 2-3X	LED 4: 0.6X	LED 3: 1-2X	LED 3: 0.4X	LED 2: 0.5-1X	LED 2: 0.2X	LED 1: 0-0.5X	LED 1: 0X
Model QS30LLP	Model QS30LLPC																			
LED 8: >6X	LED 8: >2X																			
LED 7: 5-6X	LED 7: 1.5-2X																			
LED 6: 4-5X	LED 6: 1-1.5X																			
LED 5: 3-4X	LED 5: 0.8X																			
LED 4: 2-3X	LED 4: 0.6X																			
LED 3: 1-2X	LED 3: 0.4X																			
LED 2: 0.5-1X	LED 2: 0.2X																			
LED 1: 0-0.5X	LED 1: 0X																			
Construction	ABS plastic housing; acrylic lens cover																			
Environmental Rating	IP67, NEMA 6																			
Connections	5-conductor 2 m (6.5') PVC cable, 9 m (30') PVC cable, or 5-pin integral Euro-style quick-disconnect fitting																			
Operating Conditions	Temperature: -10° to +50°C (+14° to 122°F) Max. relative Humidity: 90% @ 50°C (non-condensing)																			
Vibration and Mechanical Shock	All models meet Mil. Std. 202F requirements. Method 201A (Vibration: 10 to 60Hz max. double amplitude 0.06", maximum acceleration 10G). Also meets IEC 947-5-2 requirements: 30G, 11 ms duration, half sine wave.																			
Certifications																				

WORLD-BEAM® QS30 Series – Polarized Retroreflective Laser Sensors



CAUTION ... Do not Disassemble for Repair

Use of controls or adjustments or performance of procedures other than those specified herein may result in hazardous radiation exposure; per EN 60825. **Do NOT attempt to disassemble this sensor for repair.** A defective unit must be returned to the manufacturer.

Description of Laser Class

Class 1

Lasers that are safe under reasonably foreseeable conditions of operation, including the use of optical instruments for intrabeam viewing.

Reference 60825-1 Amend. 2 © IEC:2001(E), section 8.2.

CLASS 1 LASER PRODUCT

Complies with 21 CFR 1040.10 and 1040.11 except for deviations pursuant to Laser Notice No. 50, dated 7-26-01.



For Safe Laser Use

- Do not permit a person to stare at the laser from within the beam.
- Do not point the laser at a person's eye at close range.
- Locate open laser beam paths either above or below eye level, where practical

Dimensions

Cabled Models

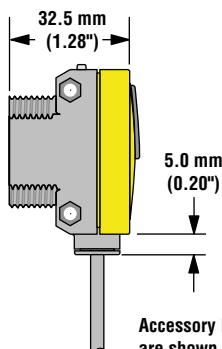

Accessory bracket dimensions are shown on page 11.

Hardware Included:
(2) M3 x 0.5 x 28 stainless steel machine screws, nuts and washers

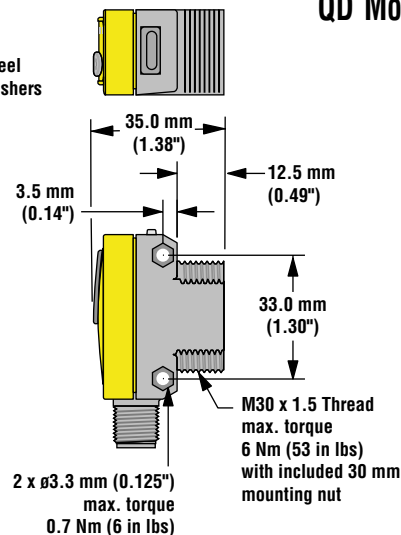
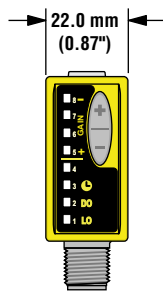

QD Models

Hookups

Cabled Models

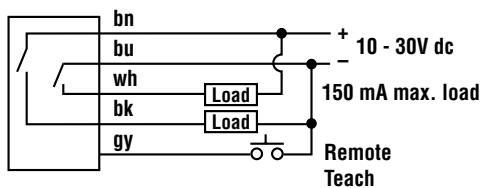

QD Models

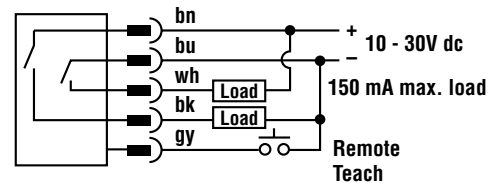

WORLD-BEAM® QS30 Series – Polarized Retroreflective Laser Sensors

Accessories

Quick-Disconnect Cables

Style	Model	Length	Dimensions	Pin-Out
5-pin Euro-style straight	MQDC1-506 MQDC1-515 MQDC1-530	2 m (6.5') 5 m (15') 9 m (30')		
5-pin Euro-style right-angle	MQDC1-506RA MQDC1-515RA MQDC1-530RA	2 m (6.5') 5 m (15') 9 m (30')		

Retroreflective Targets

Banner offers a wide selection of high-quality retroreflective targets. See the Accessories section of your current Banner Photoelectric Sensors catalog for complete information.

NOTE: Polarized sensors require corner cube type retroreflective targets only. See Retroreflector Recommendations on page 7.



<p>BRT-36X40BM</p>	<ul style="list-style-type: none"> • High-resolution corner-cube reflector (micro-prism) • 1.2 reflectivity factor* • Max. temp. +50°C (+120°F) • Supplied with sensor 	<p>BRT-TVHG-2X2</p>	<ul style="list-style-type: none"> • High-resolution corner-cube reflector (micro-prism) tape, package of four • 0.8 reflectivity factor* • Max. temp. +50°C (+120°F) • Supplied with sensor 	<p>BRT-2X2</p>	<ul style="list-style-type: none"> • Corner-cube reflector • 1.0 reflectivity factor* • Max. temp. +50°C (+120°F)

*Reflectivity factor when compared with standard BRT-3 reflector

WORLD-BEAM® QS30 Series – Polarized Retroreflective Laser Sensors

Accessory Brackets

<p>SMBQS30L</p>	<ul style="list-style-type: none"> • 14-gauge, stainless steel right-angle bracket for cable models • Clearance for M4 (#8) hardware • ± 12° tilt adjustment 	<p>SMBQS30LT</p>	<ul style="list-style-type: none"> • 14-gauge stainless steel for QD models with right-angle cables • Tall right-angle mounting bracket • ± 8° Tilt adjustment
<p>SMBQS30Y</p>	<ul style="list-style-type: none"> • Heavy-duty die-cast bracket • M18 vertical mounting option • ± 8° tilt adjustment with cabled units • Nuts and lockwasher included 	<p>SMB30SC</p>	<ul style="list-style-type: none"> • 30 mm swivel bracket, barrel mount • Black reinforced thermoplastic polyester • Includes stainless steel mounting and swivel locking hardware
<p>Other compatible mounting bracket (see Banner Photoelectric catalog or website for more information):</p> <ul style="list-style-type: none"> • SMB30MM • SMB30A 			

WORLD-BEAM® QS30 Series – Polarized Retroreflective Laser Sensors



more sensors, more solutions

WARRANTY: Banner Engineering Corp. warrants its products to be free from defects for one year. Banner Engineering Corp. will repair or replace, free of charge, any product of its manufacture found to be defective at the time it is returned to the factory during the warranty period. This warranty does not cover damage or liability for the improper application of Banner products. This warranty is in lieu of any other warranty either expressed or implied.