

ALL RIGHTS RESERVED. NO PORTION OF THIS PUBLICATION, WHETHER IN WHOLE OR IN PART CAN BE REPRODUCED WITHOUT THE EXPRESS WRITTEN CONSENT OF SPC TECHNOLOGY.

REVISIONS			DOC. NO. SPC-F004 * Effective: 12/21/98 * DCP No: 680					
DCP #	REV	DESCRIPTION	DRAWN	DATE	CHECKD	DATE	APPRVD	DATE
	A	RELEASED	JC	2/11/92				
1090	B	REVISED & UPDATED	HYD	2/12/01	J.C.	5/17/01	J.C.	5/17/01

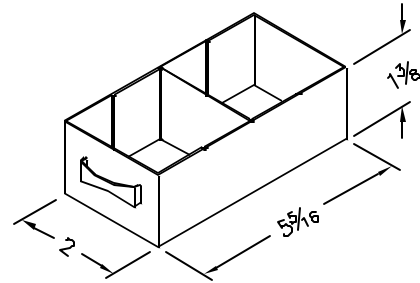
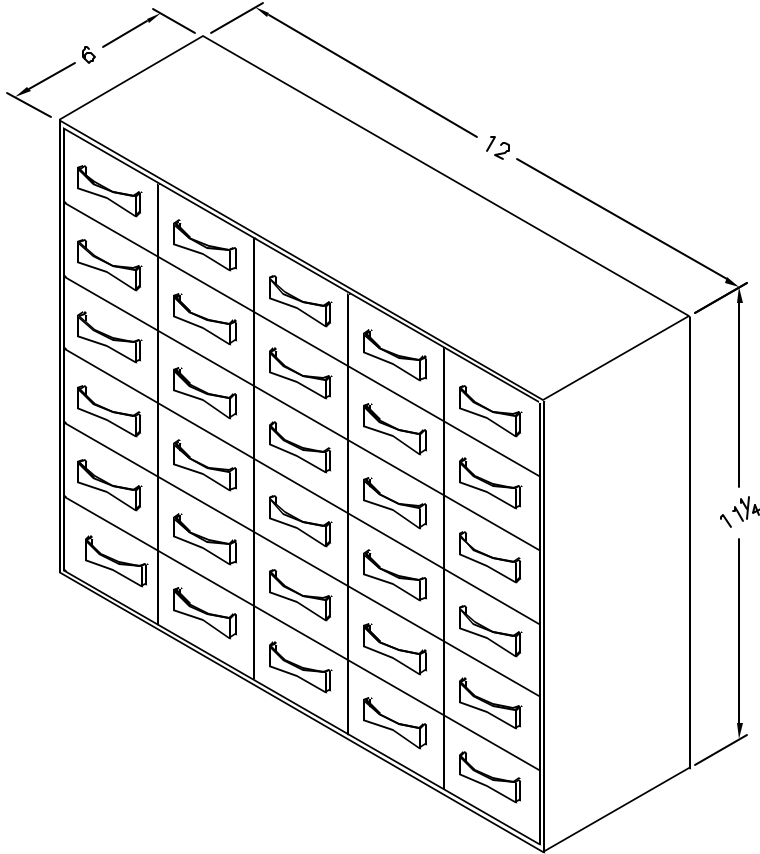

Drawer Quantity	Dividers	
	Quantity	SPC No.
30	1	DC300-1

Note: Drawer is not for sale as separate item

SPECIFICATIONS:

1. Cabinet Weight: 16.0 Lb's
2. This Cabinet is built in accordance with the guidelines of DOD-HDT3K to bleed off any static charge at safe controlled rate when properly connected to a ground.
3. Cabinet comes with static-safe ground wire that is 1Megohm 1/2 watt cord.
4. Cabinet frame, Shells, Drawer and Dividers are made of carbon filled copolymer, black.
5. Material is in compliance with MIL-B-81 705B.
6. Cabinet is Durable, Rustproof and Dent-proof.
7. Surface resistivity $10^3 - 10^6$ ohm/sq, Volume resistivity $10^3 - 10^5$ ohm/sq.

SPC-F004.DWG

DISCLAIMER:
ALL STATEMENTS AND TECHNICAL INFORMATION CONTAINED HEREIN ARE BASED UPON INFORMATION AND/OR TESTS WE BELIEVE TO BE ACCURATE AND RELIABLE. SINCE CONDITIONS OF USE ARE BEYOND OUR CONTROL, THE USER SHALL DETERMINE THE SUITABILITY OF THE PRODUCT FOR THE INTENDED USE AND ASSUME ALL RISK AND LIABILITY WHATSOEVER IN CONNECTION THEREWITH.



SPC TECHNOLOGY

UNLESS OTHERWISE SPECIFIED, DIMENSIONS ARE FOR REFERENCE PURPOSES ONLY.	DRAWN BY:	DATE:	DRAWING TITLE:			
	JOHN COLE	2/11/92	PLASTIC FRAME CONDUCTIVE STORAGE CABINET			
	CHECKED BY:	DATE:	SIZE	DWG. NO.	ELECTRONIC FILE	REV
			A	CPC-30030	84N1455.DWG	B
	APPROVED BY:	DATE:	SCALE: NTS	U.O.M.: INCHES	SHEET: 1 OF 1	