



Features

- Exceptional optical performance, comparable to larger sensors
- Simple multi-turn screw adjustment of cutoff distance
- 10 to 30V dc operation, with complementary (SPDT) NPN or PNP outputs, depending on model
- Less than 1 millisecond output response for excellent sensing repeatability

Laser Models:

- Narrow effective beam (approx. 1 mm spot size) for small-object detection and precise position control
- Crosstalk rejection algorithm to avoid optical disturbance from adjacent sensors
- Class 2 models have reduced excess gain within 20 mm of sensor for decreased susceptibility to the effects of lens contamination and to allow use of external lens shield.

Models

Models	Sensing Beam and Range	Cable*	Supply Voltage	Output Type	Excess Gain	
					Performance based on 90% reflectance white test card	
QS18VN6AF100	660 nm Visible Red LED Range: 1 mm (0.04") to cutoff point	2 m (6.5') 4-wire	10 to 30V dc	NPN		
QS18VP6AF100	Adjustable cutoff point, 20-100 mm (0.8"-4")			PNP		
QS18VN6LAF	650 nm Visible Red Class 1 Laser Range: 1 mm (0.04") to cutoff point			NPN		
QS18VP6LAF	Adjustable cutoff point, 30-150 mm (1.2"-6")			PNP		
QS18VN6LAF250	658 nm Visible Red Class 2 Laser Range: 20 mm (0.8") to cutoff point			NPN		
QS18VP6LAF250	Adjustable cutoff point, 50-250 mm (2"-10")			PNP		

*Only standard 2 m (6.5') cable models are listed above. For other cable/connector options:

- 9 m (30') cables: add suffix "W30" to the model number (e.g., QS18VN6AF100 W/30).
- 4-pin Pico-style pigtail QD: add suffix "Q" to the model number (e.g., QS18VN6AF100Q); accessory mating cordset required, see page 7.
- 4-pin Euro-style pigtail QD: add suffix "Q5" to the model number (e.g., QS18VN6AF100Q5); accessory mating cordset required, see page 7.



WORLD-BEAM® QS18 Adjustable-Field Sensors

Overview

The QS18 Adjustable Field sensor is a full-featured sensor in a miniature package. It provides background suppression sensing capability for small or difficult-to-reach areas. Models are available with a visible red LED sensing beam, or one of two visible red lasers (see Models table on page 1).

These adjustable-field sensors are able to detect objects of relatively low reflectivity, while ignoring other objects in the background (beyond the cutoff point). The cutoff distance is mechanically adjustable, using the 5-turn adjustment screw on the sensor top (Figure 1). Backgrounds and background objects must *always* be placed beyond the cutoff distance.

Adjustable-Field Sensing – Theory of Operation

The sensor compares the reflections of its emitted light beam (E) from an object back to the sensor's two differently-aimed detectors R1 and R2 (see Figure 2). If the near detector (R1) light signal is stronger than the far detector (R2) light signal (see object A, closer than the cutoff distance), the sensor responds to the object. If the far detector (R2) light signal is stronger than the near detector (R1) light signal (see object B, object beyond the cutoff distance), the sensor ignores the object.

The cutoff distance for these sensors is adjustable. Objects lying beyond the cutoff distance are ignored, even if they are highly reflective. However, it is possible to falsely detect a background object, under certain conditions (see Background Reflectivity and Placement).

In the drawings and discussion on these pages, the letters E, R1, and R2 identify how the sensor's three optical elements (Emitter "E", Near Detector "R1", and Far Detector "R2") line up across the face of the sensor. The location of these elements defines the sensing axis (see Figure 3). The sensing axis becomes important in certain situations, such as those illustrated in Figures 7 and 8.

Sensor Setup

Setting the Cutoff Distance

The cutoff distance for the QS18AF models may be adjusted between 20 mm and 100 mm (0.8" to 4"); for QS18LAF models, between 30 mm and 150 mm (1.2" to 6"); and for QS18LAF250 models, between 50 mm and 250 mm (2" to 10").

To properly set the cutoff point, position the lightest possible background to be used, at the closest position it will come to the sensor during use. Using a small screwdriver in the adjustment screw, adjust the cutoff distance until the threshold is reached and the yellow Light Sensed indicator changes state. (If the indicator never comes ON, the background is beyond the maximum sensing distance and will be ignored.) Repeat the procedure, using the darkest target, placed in its most distant position for sensing. Adjust the cutoff approximately midway between the two positions (Figure 4).

Sensing Reliability

For highest sensitivity, the sensor-to-object distance should be such that the object will be sensed at or near the point of maximum excess gain. The excess gain curves on page 1 show excess gain vs. sensing distance for the minimum and maximum cutoff settings. Maximum excess gain for model QS18VN6AF100 at a 20 mm cutoff occurs at a lens-to-object distance of about 7 mm, for example. The background must be placed beyond the cutoff distance; more reflective backgrounds should be placed even farther back. Following these two guidelines will maximize sensing reliability.

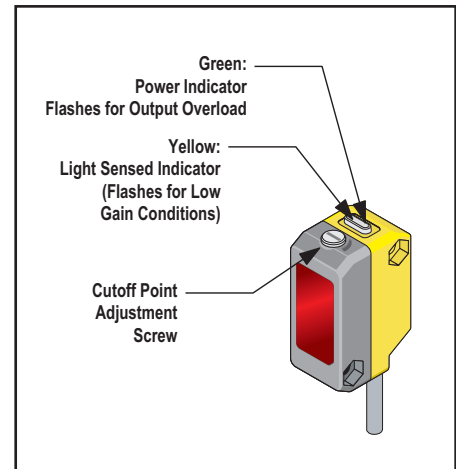

Figure 1. Sensor features

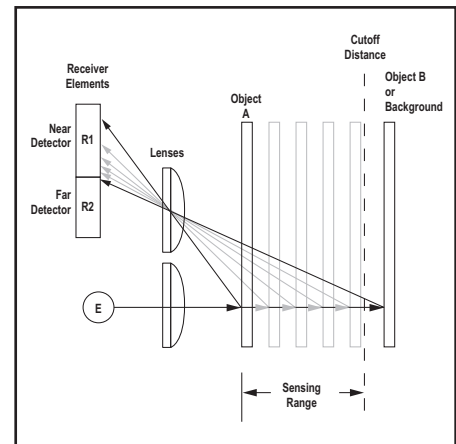

Figure 2. Adjustable field sensing concept

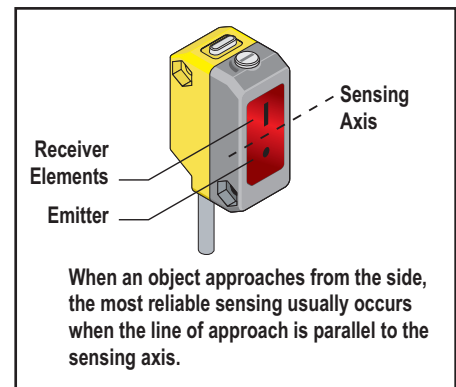

Figure 3. The sensing axis

WORLD-BEAM® QS18 Adjustable-Field Sensors

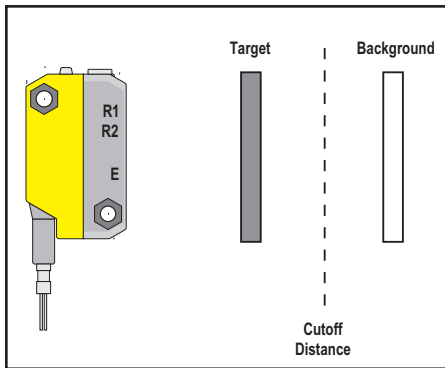

Figure 4. Set cutoff distance approximately midway between the farthest target and the closest background

Background Reflectivity and Placement

Avoid mirror-like backgrounds that produce specular reflections. False sensor response will occur if a background surface reflects the sensor's light more strongly to the near detector (R1) than to the far detector (R2). The result is a false ON condition (Figure 5). Use of a diffusely-reflective (matte) background will cure this problem. Other possible solutions are to angle either the sensor or the background (in any plane) so that the background does not reflect light back to the sensor (see Figure 6). Position the background as far beyond the cutoff distance as possible.

An object beyond the cutoff distance, either stationary (when positioned as shown in Figure 7) or if it moves past the face of the sensor in a direction perpendicular to the sensing axis, can cause unwanted triggering of the sensor if it reflects more light to the near detector than to the far detector. The problem is easily remedied by rotating the sensor 90° (Figure 8). The object then reflects the R1 and R2 fields equally, resulting in no false triggering. A better solution, if possible, may be to reposition the object or the sensor.

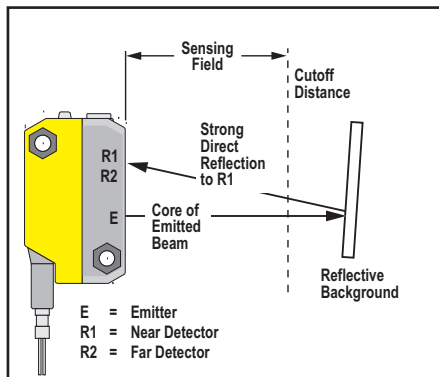

Figure 5. Reflective background – problem

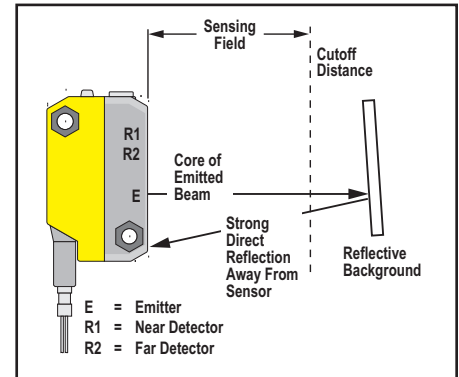

Figure 6. Reflective background – solution

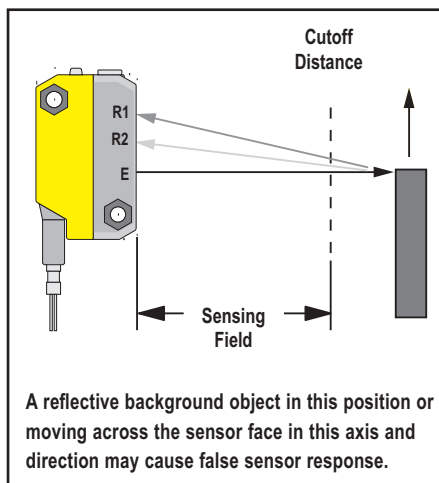

Figure 7. Object beyond cutoff – problem

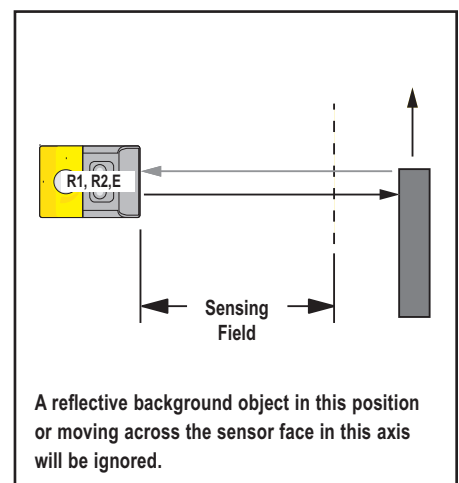

Figure 8. Object beyond cutoff – solution

WORLD-BEAM® QS18 Adjustable-Field Sensors

Color Sensitivity

The effects of object reflectivity on cutoff distance, though small, may be important for some applications.

The excess gain curves on page 1 were generated using a white test card of 90% reflectance. Objects with reflectivity of less than 90% reflect less light back to the sensor, and thus require proportionately more excess gain in order to be sensed with the same reliability as more reflective objects. When sensing an object of very low reflectivity, it may be especially important to sense it at or near the distance of maximum excess gain.

It is expected that at any given cutoff setting, the actual cutoff distance for lower reflectance targets will be slightly shorter than for higher reflectance targets (see Figures 9, 10, and 11). This behavior is known as color sensitivity.

In the graphs below, the percentage of deviation indicates a change in the cutoff point for either 18% gray or 6% black targets, relative to the cutoff point set for a 90% reflectance white test card.

For example, in Figure 9, the cutoff point decreases 10% for a 6% reflectance black target when the cutoff point is adjusted for 100 mm (4") using a 90% reflectance white test card. In other words, the cutoff point for the black target is 90 mm (3.6") for this setting.

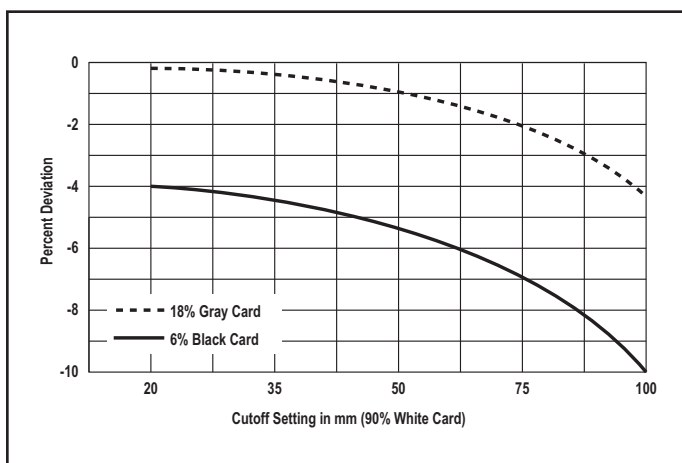

Figure 9. QS18AF cutoff point deviation

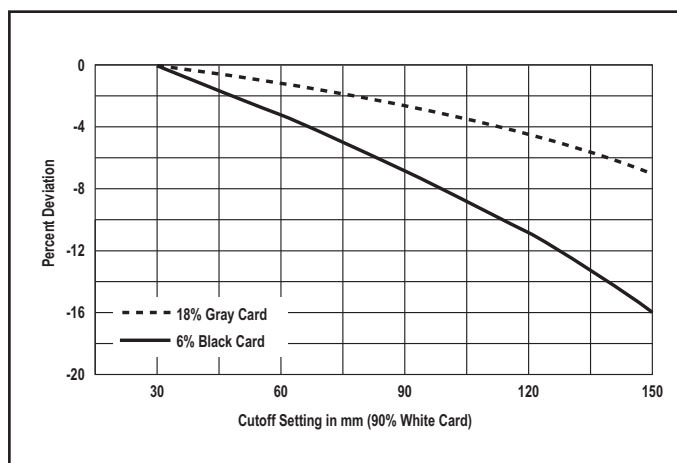

Figure 10. QS18LAF cutoff point deviation

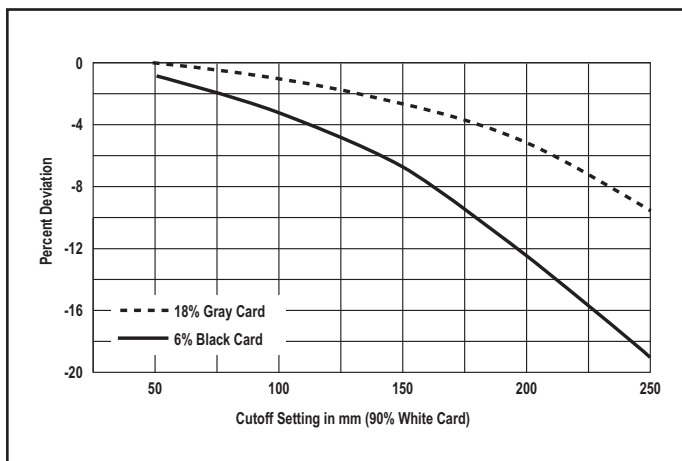



Figure 11. QS18LAF250 cutoff point deviation

WORLD-BEAM® QS18 Adjustable-Field Sensors

Specifications

	QS18AF Models	QS18LAF Models	QS18LAF250 Models
Supply Voltage	10 to 30V dc (10% maximum ripple) at less than 25 mA, exclusive of load; Protected against reverse polarity and transient voltages	10 to 30V dc (10% maximum ripple) at less than 15 mA, exclusive of load; Protected against reverse polarity and transient voltages	
Sensing Beam	Visible red LED, 660 nm	Visible red laser (see below)	
Laser Characteristics	N/A	Wavelength: 650 nm visible red Class 1 laser Pulse Width: 7 microseconds Rep Rate: 130 microseconds Average Output Power: 0.065 mW	Wavelength: 658 nm visible red Class 2 laser Pulse Width: 7 microseconds Rep Rate: 130 microseconds Average Output Power: 0.2 mW
Output Configuration	Solid-state complementary (SPDT); NPN or PNP (current sinking or sourcing), depending on model; Rating: 100 mA maximum each output at 25° C Off-state leakage current: less than 50 μ A @ 30V dc ON-state saturation voltage: less than 1V @ 10 mA; less than 1.5V @ 100 mA Protected against false pulse on power-up and continuous overload or short circuit of outputs	Solid-state complementary (SPDT); NPN or PNP (current sinking or sourcing), depending on model; Rating: 100 mA maximum each output at 25° C Off-state leakage current: NPN: less than 200 μ A @ 30V dc (See Application Note 1) PNP: less than 10 μ A @ 30V dc ON-state saturation voltage: NPN: less than 1.6V @ 100 mA PNP: less than 3.0V @ 100 mA Protected against false pulse on power-up and continuous overload or short circuit of outputs	
Output Response	700 microseconds ON/OFF; 100 ms delay on power-up; outputs do not conduct during this time	700 microseconds ON/OFF; 200 ms delay on power-up; outputs do not conduct during this time	
Repeatability	175 microseconds	130 microseconds	
Sensing Hysteresis	0.5% of range typical at 20 mm cutoff 1% of range typical at 50 mm cutoff 3% of range typical at 100 mm cutoff	1% of range typical at 30 mm cutoff 2% of range typical at 75 mm cutoff 5% of range typical at 150 mm cutoff	1% of range typical at 50 mm cutoff 2% of range typical at 150 mm cutoff 5% of range typical at 250 mm cutoff
Adjustments	Five-turn adjustment screw sets cutoff distance between min. and max. positions, clutched at both ends of travel		
Indicators	2 LED indicators on sensor top: Green ON steady: Power ON Yellow ON steady: Light sensed Yellow flashing: Marginal excess gain (1 to 1.5x excess gain)		
Construction	ABS housing, acrylic lens cover; 2.5 mm and 3 mm mounting hardware included		
Environmental Rating	IEC IP67; NEMA 6; UL Type 1		
Connections	2 m (6.5') 4-wire PVC cable, 9 m (30') PVC cable, or 4-pin Pico-style or Euro-style 150 mm (6") pigtail QD, depending on model		
Operating Conditions	Temp: 0° to +55° C (+32° to 131° F)	Temp: -10° to +50° C (+14° to 122° F)	
	Relative Humidity: 95% @ 50° C (non-condensing)		
Laser Classification	N/A	Class 1 laser product	Class 2 laser product
		Complies with IEC 60825-1:2001 and 21 CFR 1040.10, except for deviations pursuant to Laser Notice 50, dated 7-26-01	
Application Notes	1. NPN off-state leakage current is < 200 μ A for load resistances > 3 k Ω or optically isolated loads. For load current of 100 mA, leakage is < 1% of load current		
Certifications			approval in process

WORLD-BEAM® QS18 Adjustable-Field Sensors

Description of Laser Classes

Class 1 Lasers

Lasers that are safe under reasonably foreseeable conditions of operation, including the use of optical instruments for intrabeam viewing.

Reference IEC 60825-1:2001, section 8.2.

Class 1 Laser Characteristics: See specifications on page 5.

Class 2 Lasers

Lasers that emit visible radiation in the wavelength range from 400 nm to 700 nm, where eye protection is normally afforded by aversion responses, including the blink reflex. This reaction may be expected to provide adequate protection under reasonably foreseeable conditions of operation, including the use of optical instruments for intrabeam viewing.

Reference IEC 60825-1:2001, section 8.2.

Class 2 Laser Characteristics: See specifications on page 5.

For Safe Laser Use (Class 1 or Class 2):

- Do not permit a person to stare at the laser from within the beam.
- Do not point the laser at a person's eye at close range.
- Terminate the beam emitted by a Class 2 laser product at the end of its useful path. Locate open laser beam paths either above or below eye level, where practical.

CLASS 1 LASER PRODUCT

Complies with 21 CFR 1040.10 and 1040.11 except for deviations pursuant to Laser Notice No. 50, dated 7-26-01.

BANNER

Pulse Power < 5.6 mW, 650 - 670 nm, 15 kHz, 4.5 uS Pulse. Complies to 21 CFR 1040.10 & EN60825-1:2001 except for deviations pursuant to laser notice No. 50, dated 7-26-01.

**LASER LIGHT - DO NOT STARE INTO BEAM
CLASS 2 LASER PRODUCT**



CAUTION . . . Do Not Disassemble for Repair

Use of controls or adjustments or performance of procedures other than those specified herein may result in hazardous radiation exposure. **Do NOT attempt to disassemble this sensor for repair.** A defective unit must be returned to the manufacturer.

Dimensions

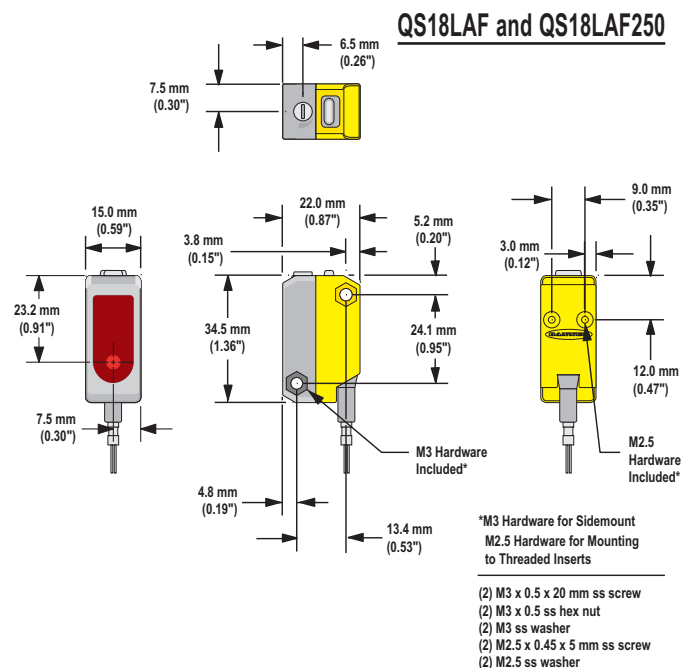
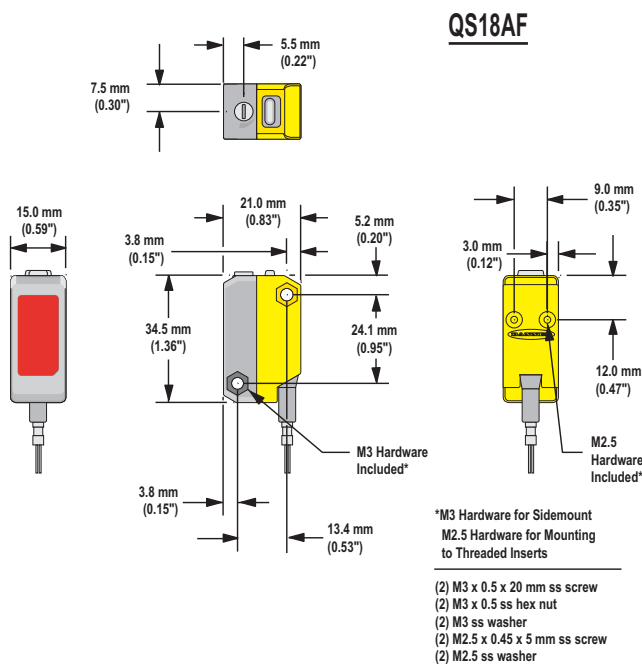

WORLD-BEAM® QS18 Adjustable-Field Sensors

Hookups

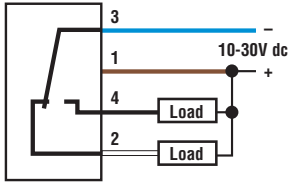

NPN (Sinking) Outputs



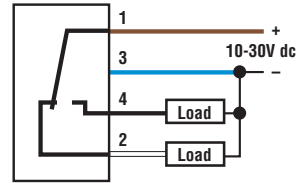

PNP (Sourcing) Outputs

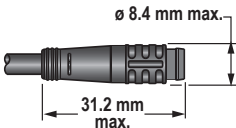

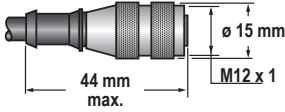
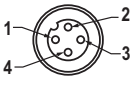
Quick-Disconnect (QD) Cordsets

Style	Model	Length	Used with:	Dimensions	Pinout
4-Pin Pico-style Straight, Snap-on Connector	PKG4-2	2 m (6.5')	QS18 with Q suffix		 <ul style="list-style-type: none"> 1 = Brown 2 = White 3 = Blue 4 = Black
4-Pin Euro-style Straight, Threaded Connector	MQDC-406 MQDC-415 MQDC-430	2 m (6.5') 5 m (15') 9 m (30')	QS18 with Q5 suffix		 <ul style="list-style-type: none"> 1 = Brown 2 = White 3 = Blue 4 = Black

Mounting Brackets

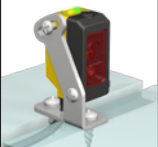
SMBQS18A	<ul style="list-style-type: none"> • Nickel-plated die-cast zinc • Wrap-around bracket 		<p>SMBQS18YL</p> <ul style="list-style-type: none"> • Heavy-duty die-cast bracket designed for industrial protection • Replaceable window • For use with Class 2 laser (adjustable-field) models only 	
SMBQS18AF	<ul style="list-style-type: none"> • 14 ga., 304 stainless steel • Right-angle mounting bracket 			

For bracket dimensions, visit www.bannerengineering.com.

WORLD-BEAM® QS18 Adjustable-Field Sensors

 **WARNING . . . Not To Be Used for Personnel Protection**

Never use these products as sensing devices for personnel protection. Doing so could lead to serious injury or death.

These sensors do NOT include the self-checking redundant circuitry necessary to allow their use in personnel safety applications. A sensor failure or malfunction can cause either an energized or de-energized sensor output condition. Consult your current Banner Safety Products catalog for safety products which meet OSHA, ANSI and IEC standards for personnel protection.



WARRANTY: Banner Engineering Corp. warrants its products to be free from defects for one year. Banner Engineering Corp. will repair or replace, free of charge, any product of its manufacture found to be defective at the time it is returned to the factory during the warranty period. This warranty does not cover damage or liability for the improper application of Banner products. This warranty is in lieu of any other warranty either expressed or implied.

P/N 66981 rev. G

Banner Engineering Corp., 9714 Tenth Ave. No., Minneapolis, MN USA 55441 • Phone: 763.544.3164 • www.bannerengineering.com • Email: sensors@bannerengineering.com