

MQ-W SERIES

Triple Beam Trigonometric Area Reflective Photoelectric Sensors

Very accurate detection by triple beam triangulation sensing method in a compact package.

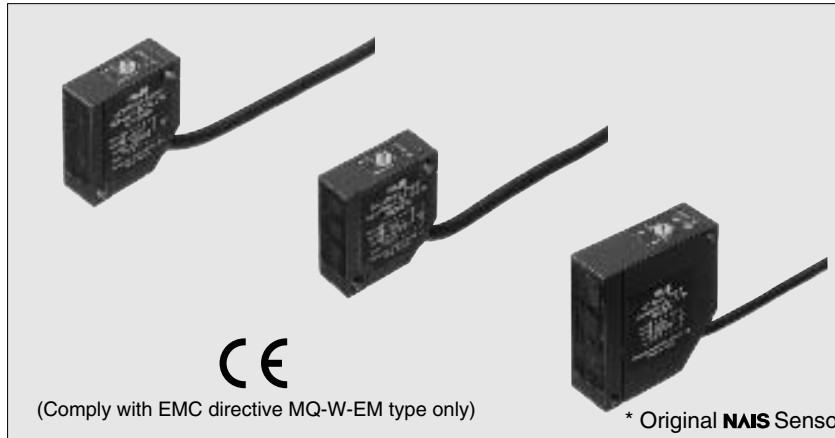

Environmental resistance
Immersion protected construction (equivalent to IEC IP67)
High speed detection: Max. 2 ms
Light-ON/Dark-ON output is wire selectable.
Operating voltage of 12 to 24 V DC
Adjuster and Indicators

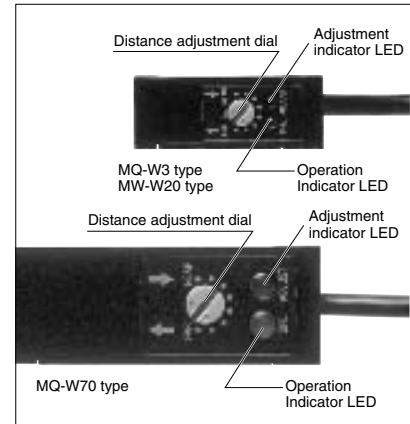

FEATURES

Accurate detection regardless of color, material, or shape of objects
Area reflective type sensor can detect white or black object at the same distance. In case of diffuse reflective type, it is difficult to detect objects of various color with the same sensitivity setting. MQ-W area reflective type sensor is useful for such a case.

No-miss operation regardless of back-grounds

Area reflective type sensor does not detect objects beyond the set range.

Resistant to lens surface soiling

Area reflective type sensor detects the distance by the angle, not the intensity of received light. Even if the lens surface is soiled by dust or any powdery material, there is a little variation of sensing range.

SENSING RANGES

	Sensing range (m ft.)		
	0.03 .098	0.2 .656	0.7 2.297
MQ-W3 types	[Bar from 0.03 to 0.098]		
MQ-W20 types	[Bar from 0.03 to 0.2]		
MQ-W70 types	[Bar from 0.03 to 0.7]		

PRODUCT TYPE

Detection method	Range	Rated operating voltage	Control output	Light source	Part number	*1 CE types	
Triple beam area reflective type	0.03 m .098 ft.	12 to 24 V DC	NPN	Infrared LED	MQ-W3A-DC12-24V	MQ-W3A-DC12-24VEM	
				Red LED	MQ-W3AR-DC12-24V	MQ-W3AR-DC12-24VEM	
			PNP	Infrared LED	MQ-W3C-DC12-24V	MQ-W3C-DC12-24VEM	
				Red LED	MQ-W3CR-DC12-24V	MQ-W3CR-DC12-24VEM	
			0.2 m .656 ft.	NPN	Infrared LED	MQ-W20A-DC12-24V	MQ-W20A-DC12-24VEM
					Red LED	MQ-W20AR-DC12-24V	MQ-W20AR-DC12-24VEM
	PNP			Infrared LED	MQ-W20C-DC12-24V	MQ-W20C-DC12-24VEM	
				Red LED	MQ-W20CR-DC12-24V	MQ-W20CR-DC12-24VEM	
	0.7 m 2.297 ft.		NPN	Infrared LED	MQ-W70A-DC12-24V	MQ-W70A-DC12-24VEM	
			PNP	Infrared LED	MQ-W70C-DC12-24V	MQ-W70C-DC12-24VEM	

*1 These suffix EM types conform to CE. These types have the grounding connection inside of housing

SPECIFICATIONS

1) Ratings

Operating side	Rated operating voltage	12 to 24 V DC
	Rated current consumption	30 mA or less (excluding load)
Load side	Output current capacity	100 mA or less

2) Performance

Detection principle	Triple beam triangulation sensing method		
Detection method	Area reflective type		
Type	Amplifier selfcontained DC type		
Part number	MQ-W3A-DC12-24V MQ-W3AR-DC12-24V MQ-W3C-DC12-24V MQ-W3CR-DC12-24V	MQ-W20A-DC12-24V MQ-W20AR-DC12-24V MQ-W20C-DC12-24V MQ-W20CR-DC12-24V	MQ-W70A-DC12-24V MQ-W70C-DC12-24V
Sensing range	0.03 m .098 ft.	0.2 m .656 ft.	0.7 m 2.297 ft.
Detectable distance	0.02 to 0.04 m .066 to .131 ft.	0.04 to 0.2 m .131 to .656 ft.	0.2 to 0.7 m .656 to 2.297 ft.
Standard target	White drawing paper 1×1 cm .394×.394 inch	White drawing paper 2×2 cm .787×.787 inch	White drawing paper 7.5×7.5 cm 2.953×2.953 inch
Detectable target	Opaque, translucent		
Hysteresis	10% or less the set range	20% or less of the set range	
Operating voltage range	9.6 to 30 V DC ripple (P-P) included		
Response time (freq.)	2 ms or less (250 times per second or less)		
Initial insulation resistance	Min. 20 MΩ between a lead wire and external housing (at 500 V DC)		
Initial breakdown voltage	Between a lead wire and external housing: 500 Vrms for 1 min		
Vibration resistance	10 to 55 Hz (1 cycle/min), double amplitude 1.5 mm .059 inch (2 h each on 3 axes)		
Shock resistance	980 m/s ² (approx. 100 G) (6 times each on 3 axes)		
Protective construction	Diecast case immersion protected (equivalent to IEC IP67)		
Usable ambient light level	Incandescent lamp	10,000 lux or less	
	Sunlight	30,000 lux or less	
Ambient temperature	-25 to 55°C -13 to +131°F (non-icing condition)		
Ambient humidity	Max. 85% RH (non-condensing condition)		
Storage temperature	-25 to 55°C -13 to +131°F		
Indicator	Operation indicator: Red LED ON with light entry Adjustment indicator: Red LED ON with sufficient volume of lights		
Light source	Infrared LED/Red LED (R is added to the suffix of W3(20)A(C) in the part No.)		

Note: Unless otherwise specified, the measurement conditions comprise rated operating voltage, power supply by battery, 20°C 68°F ambient temperature, standard target and 200 lux or less illuminance on the receiver surface.

3) Output circuit diagram

NPN Output type

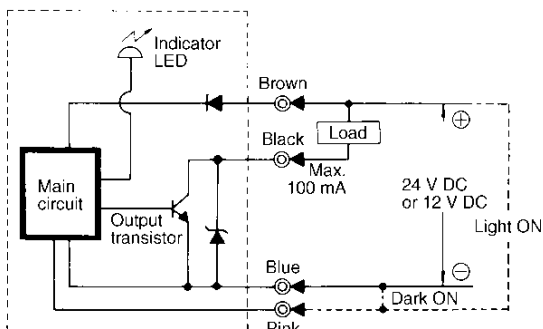

PNP Output type

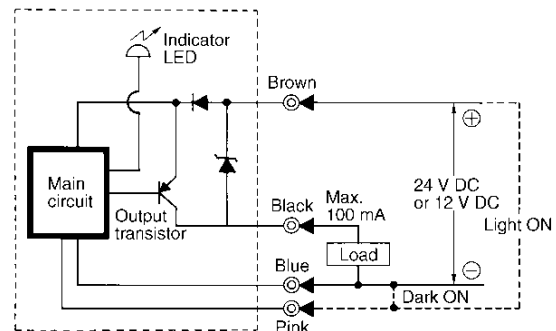

MQ-W

DATA

1. Operating range characteristics

MQ-W3 types

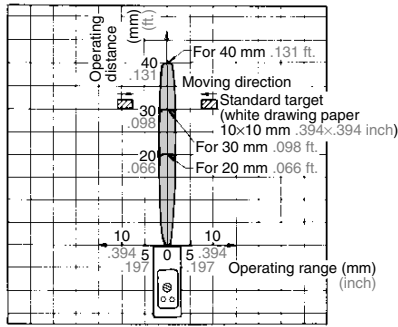

MQ-W20 types

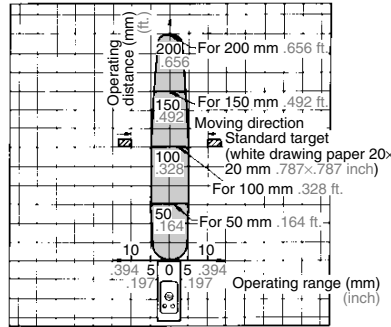

MQ-W70 types

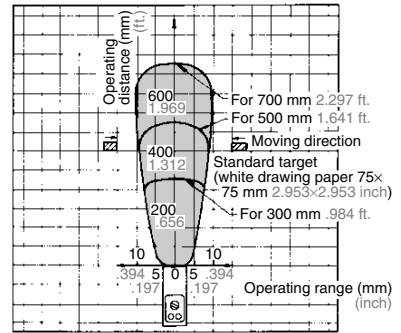

2. Projector beam diameter characteristics

Light beam diameter is determined as the region where the amount of light is decreased to $1/e^2$ ($e \approx 2.72$) when the largest amount of light is assumed as 1.

MQ-W3 types

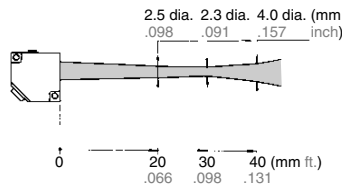

MQ-W20 types

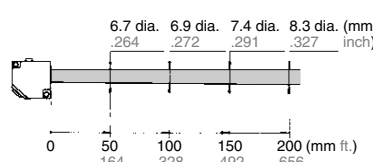

MQ-W70 types

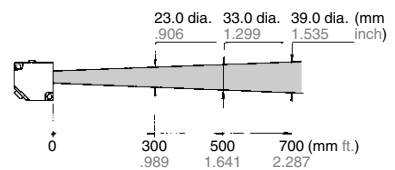

3 Detectable target characteristics

MQ-W3 types

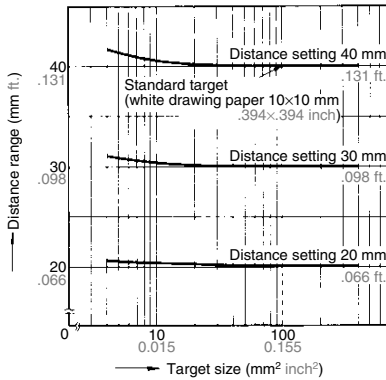

MQ-W20 types

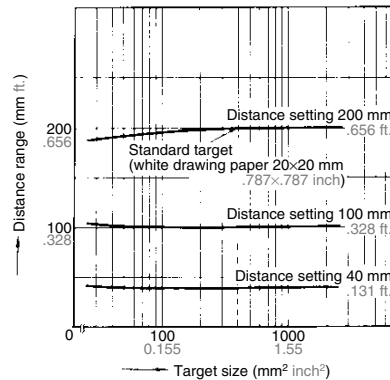

MQ-W70 types

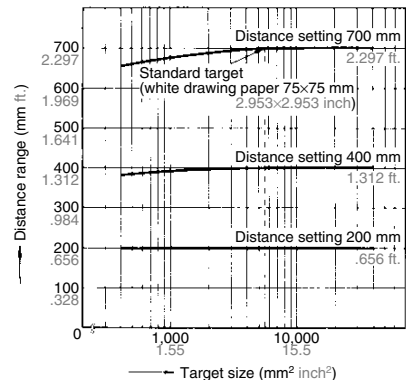

4. Material characteristics

Comparison between MQ-W20A and former product
Condition: Target (40x60 mm 1.575x2.362 inch), target assumed as natural shape
For the former product (diffuse reflective type), depending upon the object material, the operating range varied greatly, but for the triple beam type there a little variation.

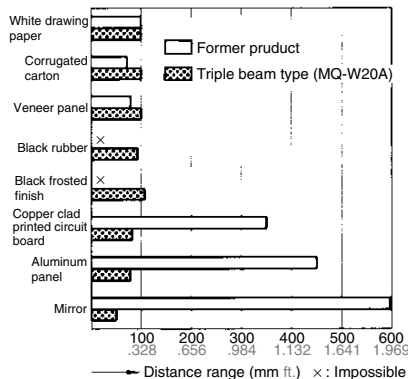

MQ-W20 types

Condition: Target (40x60 mm 1.575x2.362 inch), natural shape

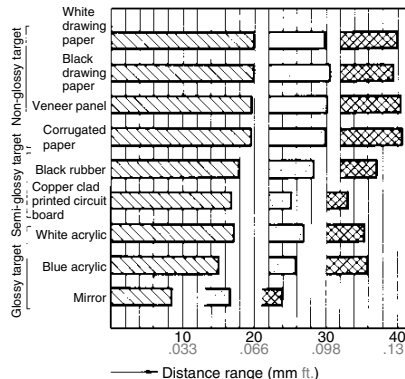

MQ-W70 types

Condition: Target (40x60 mm 1.575x2.362 inch), natural shape

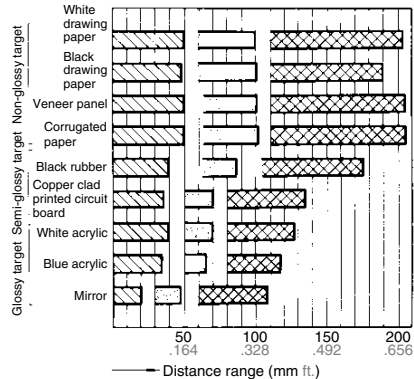

DIMENSIONS mm inch

1. MQ-W3 types

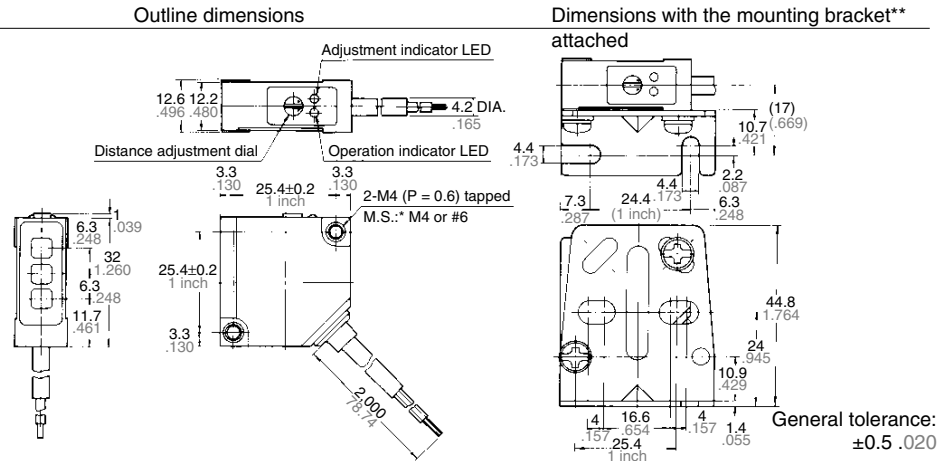

2. MQ-W20 types

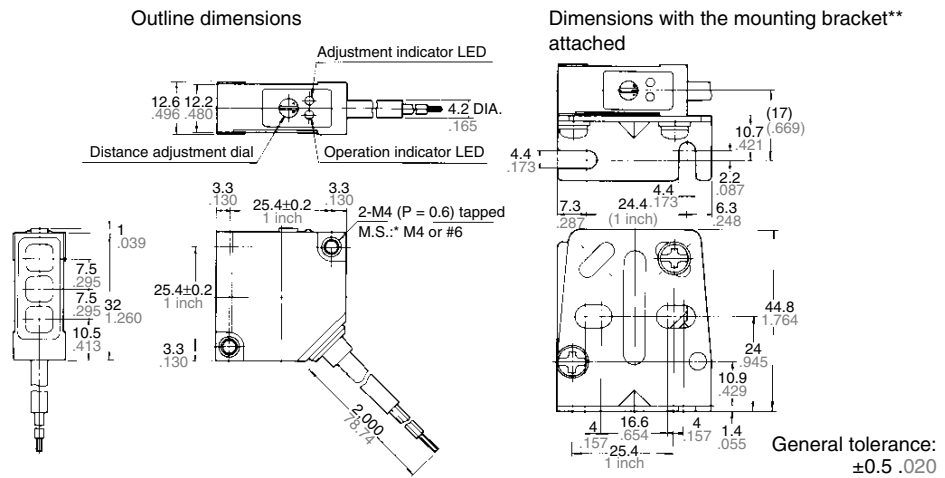

3. MQ-W70 types

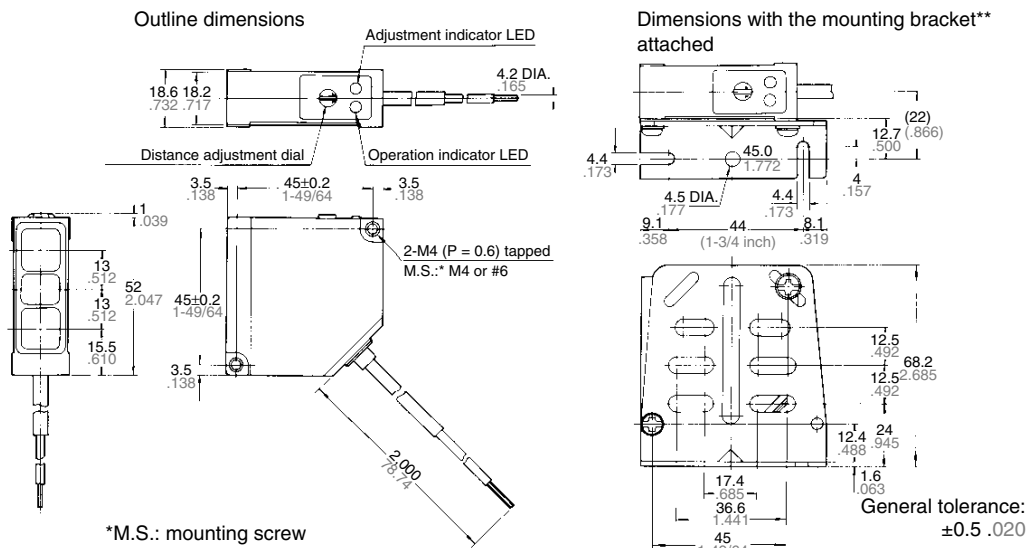

**The mounting bracket is enclosed in the inner carton.

CONNECTING DIAGRAM

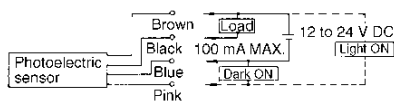

Make connection to \oplus side with pink wire for Light ON

Make connection to \ominus side with pink wire for Dark ON

Note: When switching a power source, make ground connection to the frame ground terminal or to the ground terminal. This will assure more stable operation.

Operating condition	
Output transistor	With light intercepted ON With light entering ON
Operation indicator LED	Lights with light entering

MQ-W

OPERATING PRINCIPLES

Detection principle of new triple beam area reflective series

Optical triangulation sensing method

The light beam projected by the LED, passing through the condensing lens of the light projector, is applied to the surface of the target to be detected. One part of the diffused reflected light rays passes through the light receiver lens producing a spot on the position sensitive device. When the detectable target is at a position A that is at a compar-

tively near distance as shown in Fig. 1, a spot is produced at (a). When the target is at a position B that is far, a spot is produced at (b). Accordingly, if any spot position on the position sensitive device is detected, the distance to the target can be determined. This is the principle of optical triangulation range measurement.

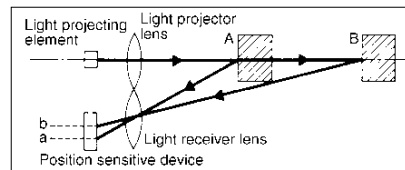

Fig. 1 Optical triangulation range measurement method

Other examples of this method are the automatic focusing and camera range measurement systems.

Triple beam type range sensing principle

The MQ photoelectric sensor area reflective type has adapted this optical triangulation range measurement principle, but in order to improve the reliability of the detection of the sensor, a more elaborate method has been devised. First, light receivers are positioned symmetrically on either side of the axis of the light projector, composing a triple beam arrangement. As shown in Fig. 2, when the moving detectable target is at the edge of the projected light beam, the spot reflected from the target is at a location different

from the point where the spot is produced when the beam is completely intercepted, generating a range measurement difference of $+\Delta X$, but with the triple beam composition, the symmetrically arranged position sensitive device (2) has a spot produced conversely at a $-\Delta X$ difference position, and by means of averaging both range measurement signals, the correct range measurement can be made. This results in significantly improved repeatability and background suppression.

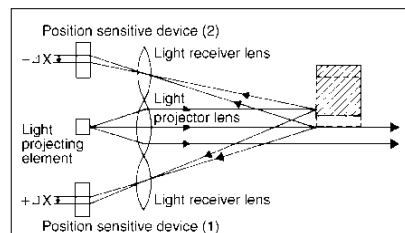

Fig. 2 Triple beam range measurement method

By averaging the range measurement signals of the 2 light receiving systems, the range measurement difference is cancelled.

Optical system of the triple beam photoelectric sensor

In the MQ photoelectric sensor area reflective type, it is necessary to give special consideration to the lens. In order to improve the precision, an aspherical lens, having limited spherical and coma aberration, is used. In addition, as shown in Fig. 4, a photo diode having 2 output terminals is used. By comparing the output currents from the 2 PSDs, there is no relationship to the level of the incident light. Thus, the ratio of reflection from the detectable target exerts no influence and the range measurement and detection can be interpreted accurately.

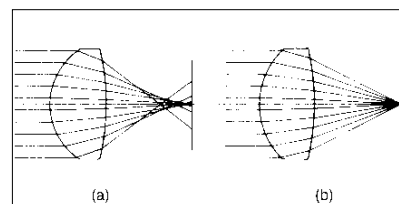

Fig. 3 Light beam trace of the lens (a) is a spherical lens, and (b) is the aspherical lens. Because there is no aberration in (b), range measurement precision is high.

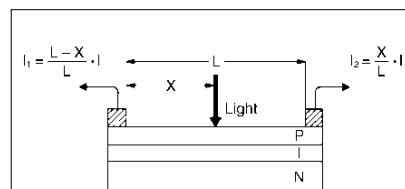

Fig. 4 PSD (position sensitive device) construction

By making a calculation of the ratio of I_1 and I_2 , the light spot position can be detected.

Operating principle of area reflective method

The operation of the MQ photoelectric sensor area reflective type is explained in Fig. 5. After the output from the 2 PSD elements is added, the I/V value is converted and the logarithm determined. By subtraction, the distance signal in (I_1/I_2) is obtained. This can be optionally set, and with the distance adjustment control, comparison with the produced value can be made to detect whether the target is or is not within the distance range.

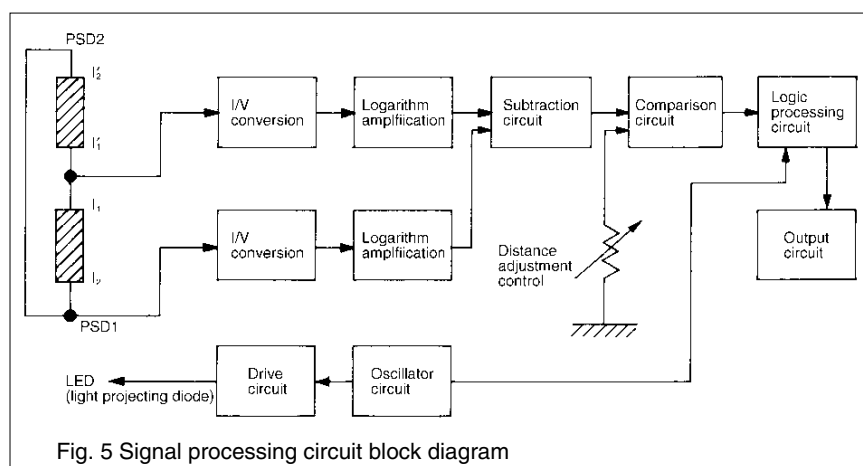

Fig. 5 Signal processing circuit block diagram

CAUTIONS



1. Ambient environment

- 1) Use within the range of ambient temperature of -25 to $+55^{\circ}\text{C}$ -13 to $+131^{\circ}\text{F}$.
- 2) Use within a range of 9.6 V to 30 V DC (ripple P-P included) for operating voltage.
- 3) Use with an ambient light level at the light receiving surface of less than $10,000\text{ lux}$ for incandescent lamp and less than $30,000\text{ lux}$ for sunlight.
- 4) Use a surge absorber as the internal circuit may be damaged if external surge voltage exceeds 500 V [$\pm(1.2 \times 50)\text{ }\mu\text{s}$ of single polarity full-wave voltage].

Surge wave form [$\pm(1.2 \times 50)\text{ }\mu\text{s}$ of single polarity full wave voltage]

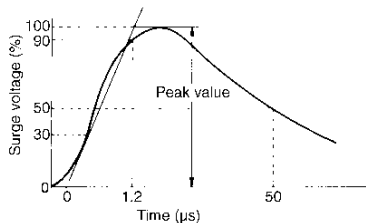

- 5) Avoid using in a location with high concentrations of steam, dust, or corrosive gas.
- 6) The sensor is of immersion protected type, but this does not mean that it can be used in water or where there is direct impingement of rain for detecting objects.

2. Connections

- 1) Check all wiring before applying power since incorrect wiring may damage the internal circuit.
- 2) Use a load relay with a rated operating voltage of 12 V DC or 24 V DC. The voltage applied to the load relay is the operating voltage of the photoelectric sensor minus the internal voltage drop (1.2 V). Voltage fluctuations should be taken into account.

- 3) If a load greater than 100 mA is connected, the output section will be damaged, so sufficient care should be taken.
- 4) If the wiring to the photoelectric sensors run parallel to high voltage or power lines, due to inductive noise, mis-operation or damage can occur. Wiring should be run in separate.
- 5) Wire 0.3 mm^2 $.0005\text{ inch}^2$ AWG22 or larger should be used for wiring up to a length of 100 m 328 ft.
- 6) When the photoelectric sensors being mounted, if the unit is struck by a hammer or other heavy tool, the function can be impaired. Sufficient care should be taken.
- 7) The changeover from Light-ON (light entry ON) to Dark-ON (light intercepted OFF) can be carried out with the pink lead wire. For Light-ON, connect the pink wire to the \oplus side, and for Dark-ON, connect the pink wire to the \ominus side.

3. Distance adjustment

- 1) Set the detecting surface of the photoelectric sensor in the detecting direction and temporarily fasten it.
- 2) While no target in the detection region, set the distance adjustment dial to maximum (FAR) and slowly turn it counterclockwise. Continue turning the control counterclockwise until the operation indicator LED (OPE.) is extinguished. This is the adjustment position. If the indicator LED is extinguished at the maximum position, that is the adjustment position.
- 3) With target in the detection area, set the dial in the minimum position (NEAR) and turn the control clockwise to locate the position where the indicator LED turns ON. If the indicator LED goes ON at the minimum position, then NEAR is the adjustment position.
- 4) Set the control to a point midway between the locations found in 2) and 3) above.
- 5) Securely fasten the photoelectric sensor. When fastening, the sensor should be sufficiently secure so that it will not shift under vibration of shock.

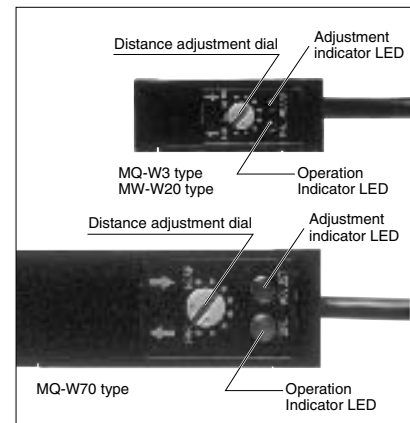

Notes:

1. If the adjustment indicator LED does not light in the adjustment of 3) as prescribed, or if the position between 2) and 3) is less than 2 graduations, change the position of the detection surface and repeat the procedure of 1) to 4), or try to determine the source of external factors such as variation in ambient temperature, variation in target position, etc., that creating the problem.
2. The difference in detection distance due to the colors of the target is virtually non-existent, but if the actual target is one where the reflectivity is extremely low (target which have a frosted finish produced by black rubber), or where the reflectivity is extremely high (mirror, glass, or truly reflecting target), confirmation should be done with the actual target.

4. Detector

- 1) Keep the detector surface clean as excessive dust or dirt on the detector surface will decrease the margin of the distance range.
- 2) The front surface of the lens is made of polycarbonate. This material is resistant to water, weak acids and alkalis, aliphatic hydrocarbons, oils, etc., but it is not resistant to ketones, esters, halogenated hydrocarbons, or aromatic hydrocarbons.