

Data Sheet

Description

HDJD-S822-QR999 is a high performance, small in size, cost effective light to voltage converting sensor. The sensor combines a photodiode array and three transimpedance amplifiers in a single monolithic CMOS IC solution. With a Red (R), Green (G) and Blue (B) color filters coated over the photodiode array, the sensor converts RGB light to analog voltage outputs, denoted by VROUT, VGOUT and VBOU, respectively. The sensor is packaged in a 5x5x0.75 [mm] surface mount QFN-16 package.

Applications

- Ideal choice of for open loop and closed loop color identification
- Potential applications are such as general color detection, industrial process, environmental lighting, cabin lighting, decorative lighting and etc.

Features

- Convert light to R,G,B voltage output
- Monolithic CMOS IC solution comprises of an array of photodiode coated with R,G, B color filter and integrated with trans-impedance amplifier
- Independent gain selection options for each R,G,B channel
- Uniform photodiode array design to minimize the effect of contamination and optical aperture misalignment
- Robust package and small in size (5x 5x 0.75 mm)

Package Dimensions

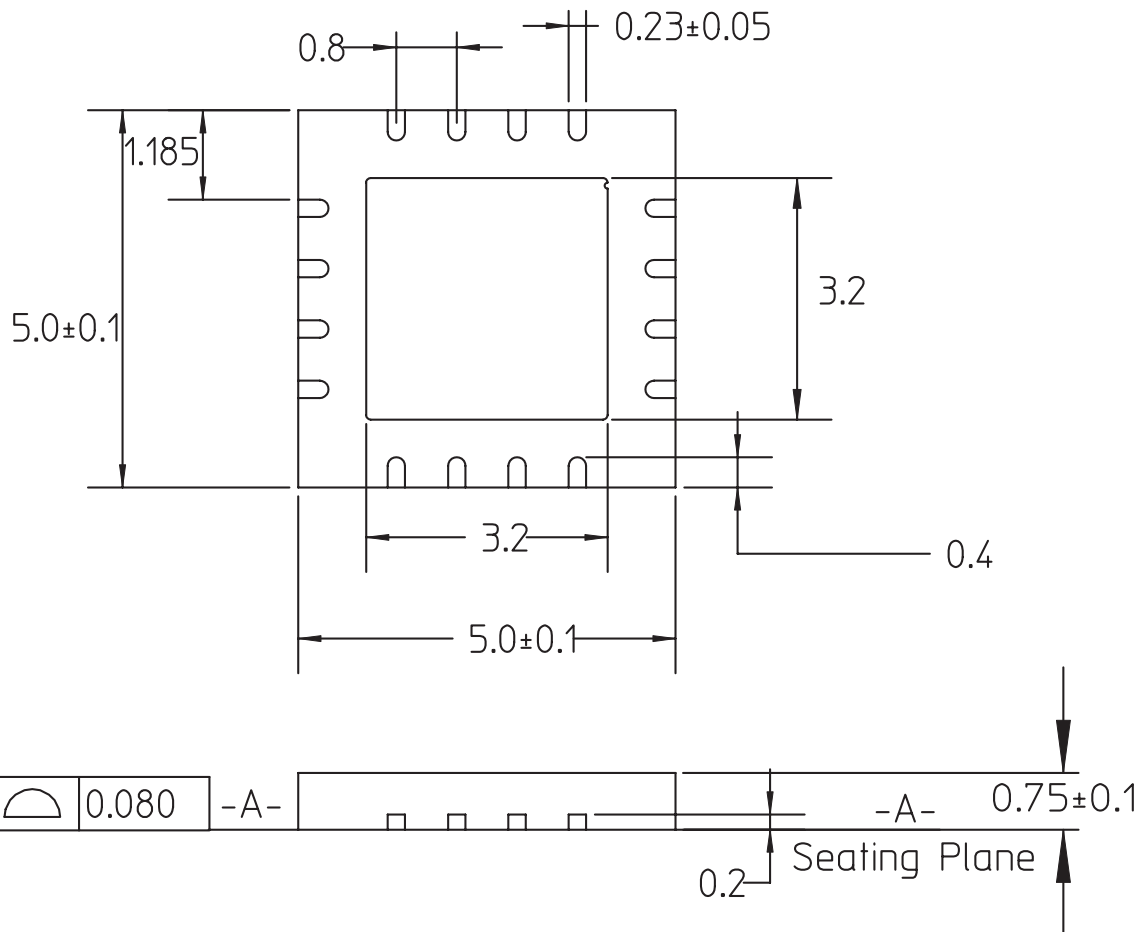
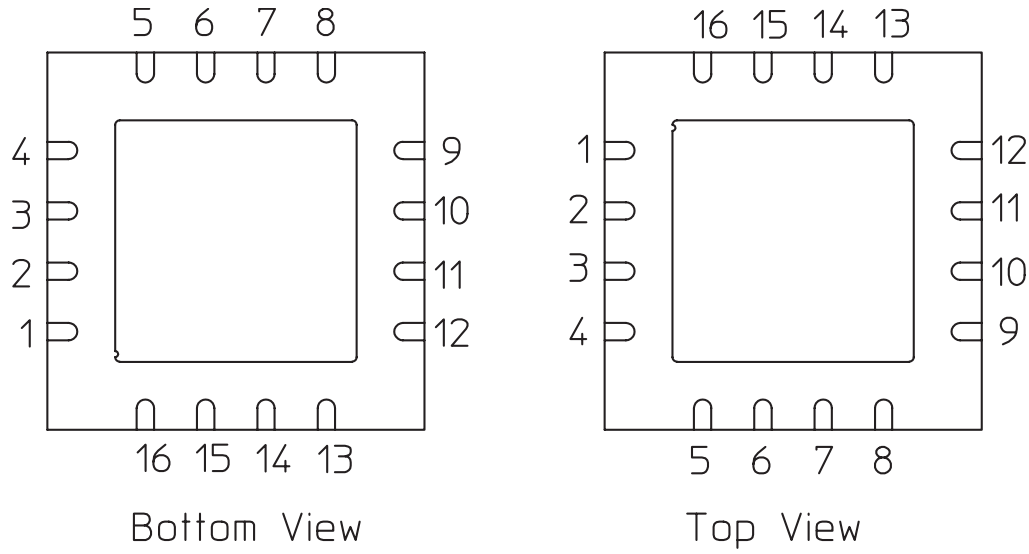

Note: Dimensions are in millimeters (mm)

Part Numbering Systems

HDJD-S 8 XX - XXXXX

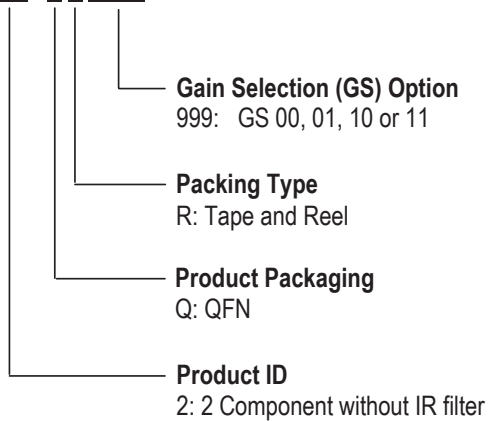

Pin Out for HDJD-S822-QR999

Pin	Pin Name	Normal Operation
Pin 1	VDD5	5 V DC Supply
Pin 2	GND	Ground
Pin 3	GSGRNO	Gain Selection Green bit 0
Pin 4	VDD3	3.3V DC output test pin. To be connected to a decoupling capacitor of 100nF to ground is recommended
Pin 5	TEST_EN	Tie to VDD3 via a 10kΩ pull up resistor
Pin 6	GSRED1	Gain Selection Red bit 1
Pin 7	NC	No connection
Pin 8	GSGRN1	Gain Selection Green bit 1
Pin 9	VR _{OUT}	Analog output voltage for RED
Pin 10	VG _{OUT}	Analog output voltage for GREEN
Pin 11	GSBLUE0	Gain Selection Blue bit 0
Pin 12	VB _{OUT}	Analog output voltage for BLUE
Pin 13	GSBLUE1	Gain Selection Blue bit 1
Pin 14	NC	No connection
Pin 15	NC	No connection
Pin 16	GSREDO	Gain Selection Red bit 0

Theory of Operation

The integral R,G,B color filters on the photodiode array detect the R,G,B components of the light falling on the sensor. The photodiode convert the R,G,B light components into photocurrents. The integrated transimpedance amplifiers for R,G,B components then converts the photocurrent into analog voltage outputs. The voltage output of each R,G,B channel increases linearly with increasing light intensity.

Sensor IC Block Diagram

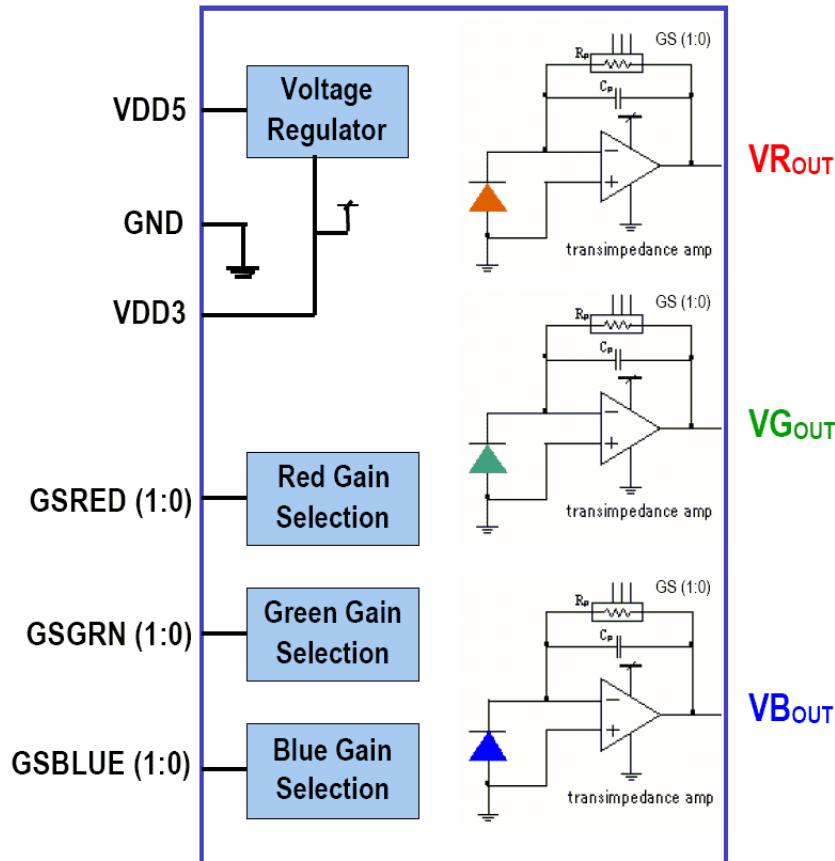

Absolute Maximum Ratings [1,2]

Parameter	Symbol	Min	Max	Unit	Notes
Supply Voltage	V_{DD5}	4.5	5.5	V	
Storage Temperature	T_S	-20	85	°C	
Operating Temperature	T_A	-20	85	°C	
Human Body Model ESD Rating	ESD HBM		2	kV	Reference to JESD22-A114-B

Note:

1. Stresses beyond those listed under "absolute maximum ratings" may cause permanent damage to the device. These are stress ratings only, and functional operation of the device at these or any other conditions beyond those indicated under "recommended operating conditions" is not implied. Exposure to absolute-maximum-rated conditions for extended periods may affect device reliability.
2. Unless otherwise specified, voltages are referenced to ground.

Recommended Operating Conditions

Parameter	Symbol.	Min	Typ	Max	Units	Note
Operating Temperature	T_A	0	25	70	°C	
Supply Voltage	V_{DD}		5.0		V	A decoupling capacitor of 100nF between VDD and ground is recommended.

Operating Conditions and Electrical Requirements

Electrical Characteristics at $V_{DD} = 5V$, $T_A = 25^\circ C$, $R_L = 68k\Omega$

Parameter	Symbol	Conditions	Min	Typ	Max	Unit
Dark voltage	V_D	$E_e = 0$			15	mV
Maximum output voltage swing	V_{O_MAX}			3		V
Supply current	I_{DD}	$E_e = 0$		3		mA
Parameter	Symbol	Remark	Min	Typ	Max	Unit
Irradiance Responsivity	Re	GS:00 $\lambda_p = 460\text{ nm}$ ^[1] (Blue Channel)		1.54		V/(mW/cm ²)
		GS:00 $\lambda_p = 542\text{ nm}$ ^[2] (Green Channel)		2.05		
		GS:00 $\lambda_p = 645\text{ nm}$ ^[3] (Red Channel)		2.73		
Irradiance Responsivity	Re	GS:11 $\lambda_p = 460\text{ nm}$ ^[1] (Blue Channel)		0.77		V/(mW/cm ²)
		GS:11 $\lambda_p = 542\text{ nm}$ ^[2] (Green Channel)		1.03		
		GS:11 $\lambda_p = 645\text{ nm}$ ^[3] (Red Channel)		1.37		
Irradiance Responsivity	Re	GS:01 $\lambda_p = 460\text{ nm}$ ^[1] (Blue Channel)		0.39		V/(mW/cm ²)
		GS:01 $\lambda_p = 542\text{ nm}$ ^[2] (Green Channel)		0.51		
		GS:01 $\lambda_p = 645\text{ nm}$ ^[3] (Red Channel)		0.68		
Irradiance Responsivity	Re	GS:10 $\lambda_p = 460\text{ nm}$ ^[1] (Blue Channel)		0.21		V/(mW/cm ²)
		GS:10 $\lambda_p = 542\text{ nm}$ ^[2] (Green Channel)		0.27		
		GS:10 $\lambda_p = 645\text{ nm}$ ^[3] (Red Channel)		0.36		

Parameter	Symbol	Remark	Min	Typ	Max	Unit
Saturation Irradiance ^[4]		GS:00 $\lambda_p = 460 \text{ nm}$ ^[1] (Blue Channel)		1.95		mW/cm ²
		GS:00 $\lambda_p = 542 \text{ nm}$ ^[2] (Green Channel)		1.46		
		GS:00 $\lambda_p = 645 \text{ nm}$ ^[3] (Red Channel)		1.10		
Saturation Irradiance ^[4]		GS:11 $\lambda_p = 460 \text{ nm}$ ^[1] (Blue Channel)		3.90		mW/cm ²
		GS:11 $\lambda_p = 542 \text{ nm}$ ^[2] (Green Channel)		2.93		
		GS:11 $\lambda_p = 645 \text{ nm}$ ^[3] (Red Channel)		2.20		
Saturation Irradiance ^[4]		GS:01 $\lambda_p = 460 \text{ nm}$ ^[1] (Blue Channel)		7.79		mW/cm ²
		GS:01 $\lambda_p = 542 \text{ nm}$ ^[2] (Green Channel)		5.85		
		GS:01 $\lambda_p = 645 \text{ nm}$ ^[3] (Red Channel)		4.40		
Saturation Irradiance ^[4]		GS:10 $\lambda_p = 460 \text{ nm}$ ^[1] (Blue Channel)		14.61		mW/cm ²
		GS:10 $\lambda_p = 542 \text{ nm}$ ^[2] (Green Channel)		10.98		
		GS:10 $\lambda_p = 645 \text{ nm}$ ^[3] (Red Channel)		8.24		
Output Rise Time	tr	GS:10 to GS11 Test Condition: Refer to note ^[5]		15		μs
		GS:00 Test Condition: Refer to note ^[5]		110		
Output Fall Time	tf	GS:10 to GS11 Test Condition: Refer to note ^[5]		15		μs
		GS:00 Test Condition: Refer to note ^[5]		120		

Notes:

1. Test condition: using blue diffuse light of peak wavelength (λ_p) 460nm and spectral half width ($\Delta\lambda_{1/2}$) 20nm as light source.
2. Test condition: using green diffuse light of peak wavelength (λ_p) 542nm and spectral half width ($\Delta\lambda_{1/2}$) 35nm as light source.
3. Test condition: using red diffuse light of peak wavelength (λ_p) 645nm and spectral half width ($\Delta\lambda_{1/2}$) 20nm as light source.
4. Saturation irradiance = (Max output voltage swing)/(Irradiance responsivity)
5. Test condition: The rise and fall time is measured with RC lowpass filter added to sensor output:

Gain Selection	Rext	Cext
GS:01 to GS:11	3.6k Ω	1nF
GS:00	36k Ω	1nF

Test Circuit

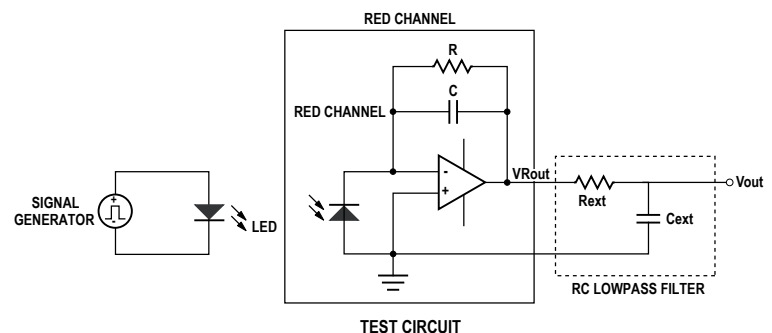

FOR ILLUSTRATION PURPOSE, ONLY RED CHANNEL IS SHOWN. THE SAME CIRCUIT APPLIES TO GREEN AND BLUE CHANNELS.

Remarks: For illustration purpose, only red channel is shown. The same circuit applies to green and blue channel.

Gain Selection Feedback Resistor Table

GSRED1	GSRED0	GSGRN1	GSGRN0	GSBLUE1	GSBLUE0	Feedback Resistor
0	0	0	0	0	0	3.00 M Ω
0	1	0	1	0	1	0.75 M Ω
1	0	1	0	1	0	0.40 M Ω
1	1	1	1	1	1	1.50 M Ω

Notes:

1. Gains selections, GS: Bit 1 Bit 0 are applicable for each Red, Green and blue Channel.
2. Gain selections for each channel can be selected independently of each other.
3. Feedback resistor value is proportional to responsivity. Refer to block diagram below.
4. 0 indicates that the pin is connected to ground. 1 indicates no connection.

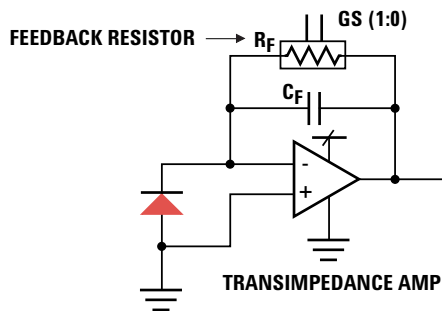

Typical Characteristics

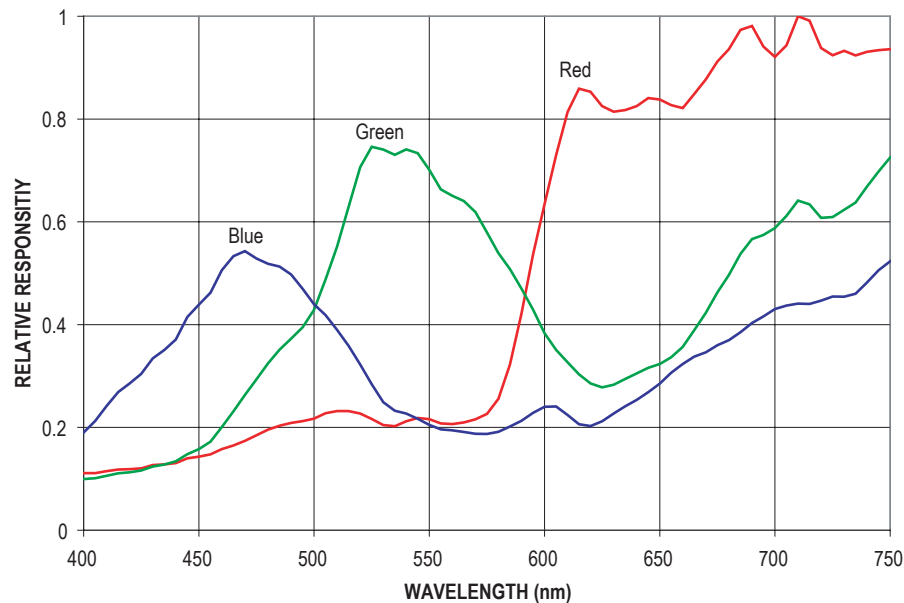

Figure 1. Spectral Responsivity

Note:

Test condition is when Gain Selection Jumpers are set to

GSBLUE1 = 0	GSGRN1 = 0	GSRED1 = 0
GSBLUE0 = 0	GSGRN0 = 0	GSRED0 = 0

In which 0 = connect to Ground, 1 = no connection.

Refer to Gain Selection Feedback Resistor Table.

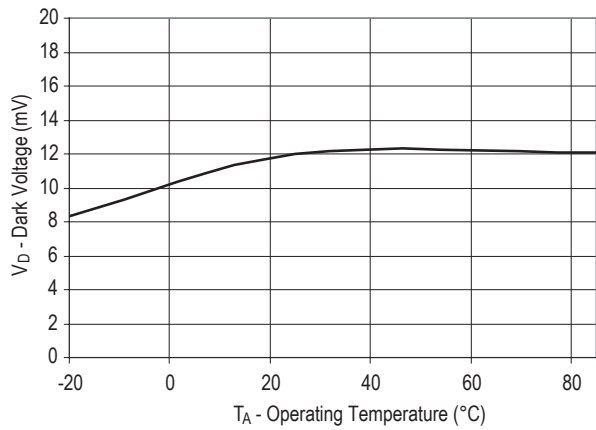

Figure 2. Dark Voltage vs Operating Temperature

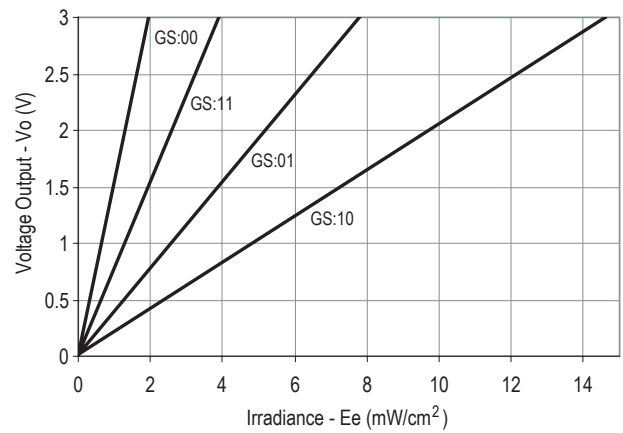

Figure 3. Voltage output of blue channel vs irradiance ($\lambda_p = 460$ nm)

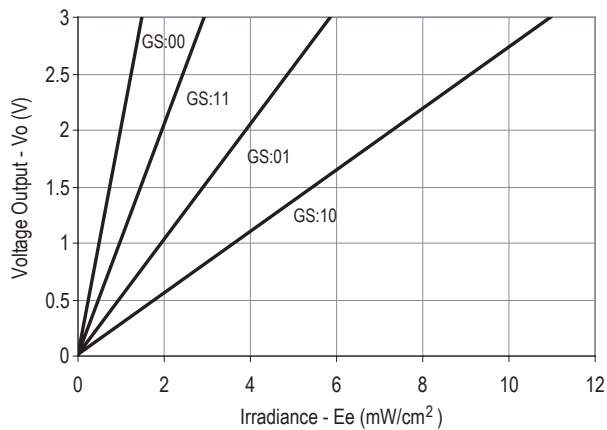

Figure 4. Voltage output of green channel vs irradiance ($\lambda_p = 542$ nm)

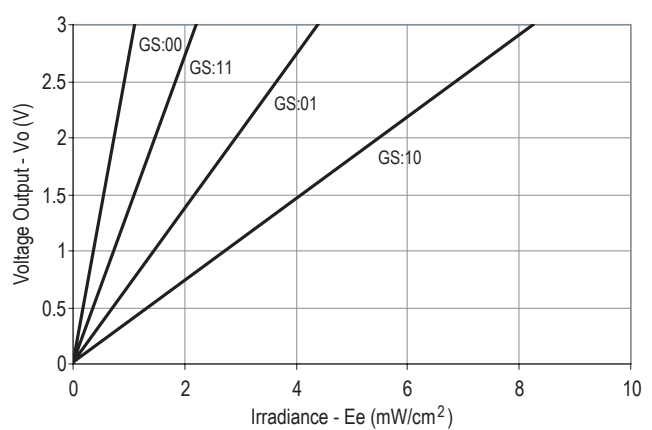

Figure 5. Voltage output of red channel vs irradiance ($\lambda_p = 645$ nm)

Recommended Reflow Profile

It is recommended that Henkel Pb-free solder paste LF310 be used for soldering HDJD-S822-QR999. Below is the recommended reflow profile.

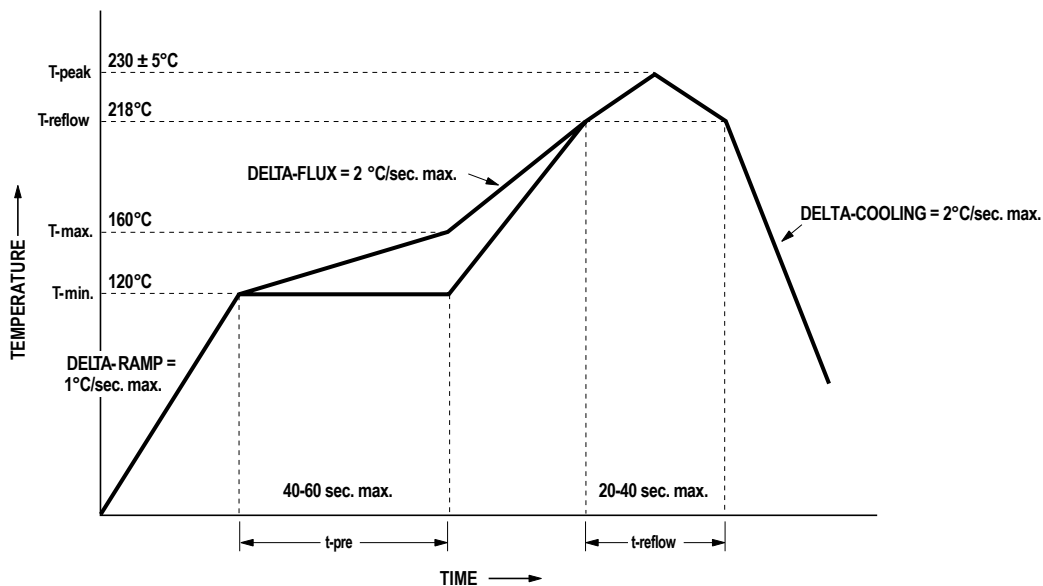
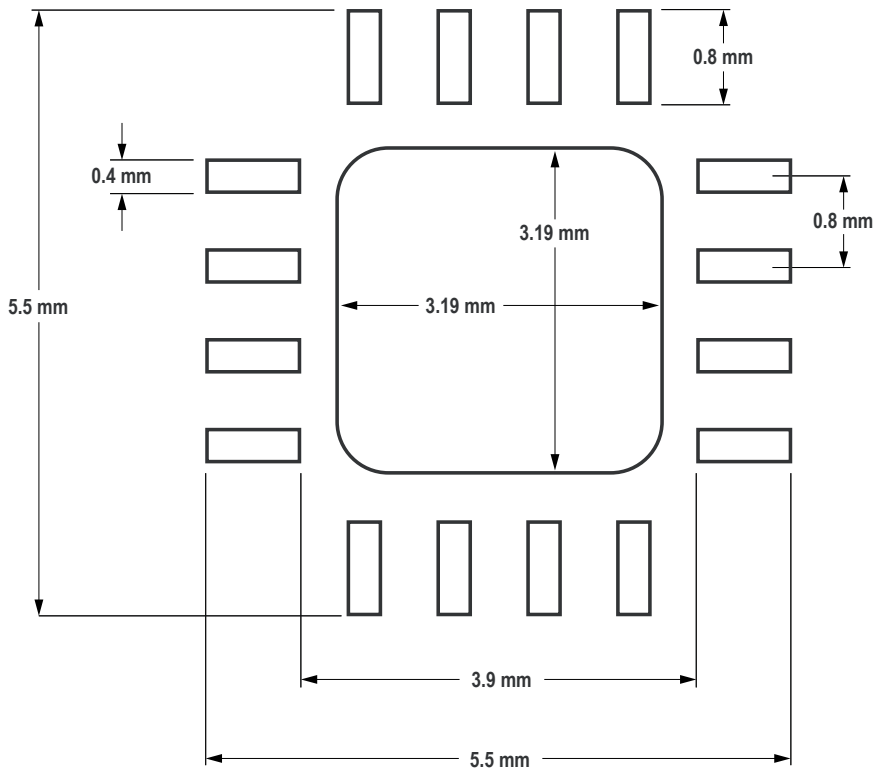

Figure 6. Recommended Reflow Soldering Profile

16 Lead QFN Recommended PCB Land Pad Design

IPC-SM-782 is used as the standard for the PCB land pad design. Recommended PCB finishing is Gold.



16 Lead QFN Recommended Stencil Design

A stencil thickness of 2.18mm (6 mils) for this QFN package is recommended.

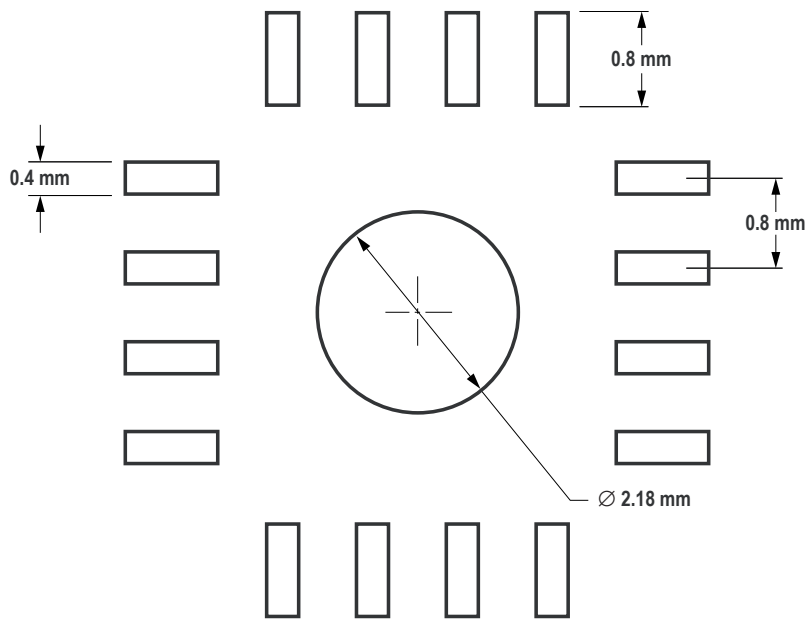

Recommendations for Handling and Storage of HDJD-S822-QR999

This product is qualified as Moisture Sensitive Level 4 per J-STD-020. Precautions when handling this moisture sensitive product is important to ensure the reliability of the product. Do refer to Avago Application Note AN5305 Handling Of Moisture Sensitive Surface Mount Devices for details.

A. Storage before use

- Unopened moisture barrier bag (MBB) can be stored at 30°C and 90%RH or less for maximum 1 year
- It is not recommended to open the MBB prior to assembly (e.g. for IQC)
- It should also be sealed with a moisture absorbent material (Silica Gel) and an indicator card (cobalt chloride) to indicate the moisture within the bag

B. Control after opening the MBB

- The humidity indicator card (HIC) shall be read immediately upon opening of MBB
- The components must be kept at <30°C/60%RH at all time and all high temperature related process including soldering, curing or rework need to be completed within 72hrs

C. Control for unfinished reel

- For any unused components, they need to be stored in sealed MBB with desiccant or desiccator at <5%RH

D. Control of assembled boards

- If the PCB soldered with the components is to be subjected to other high temperature processes, the PCB need to be stored in sealed MBB with desiccant or desiccator at <5%RH to ensure no components have exceeded their floor life of 72hrs

E. Baking is required if:

- "10%" or "15%" HIC indicator turns pink
- The components are exposed to condition of >30°C/60%RH at any time.
- The components floor life exceeded 72hrs
- Recommended baking condition (in component form): 125°C for 24hrs

Package Tape & Reel Dimensions

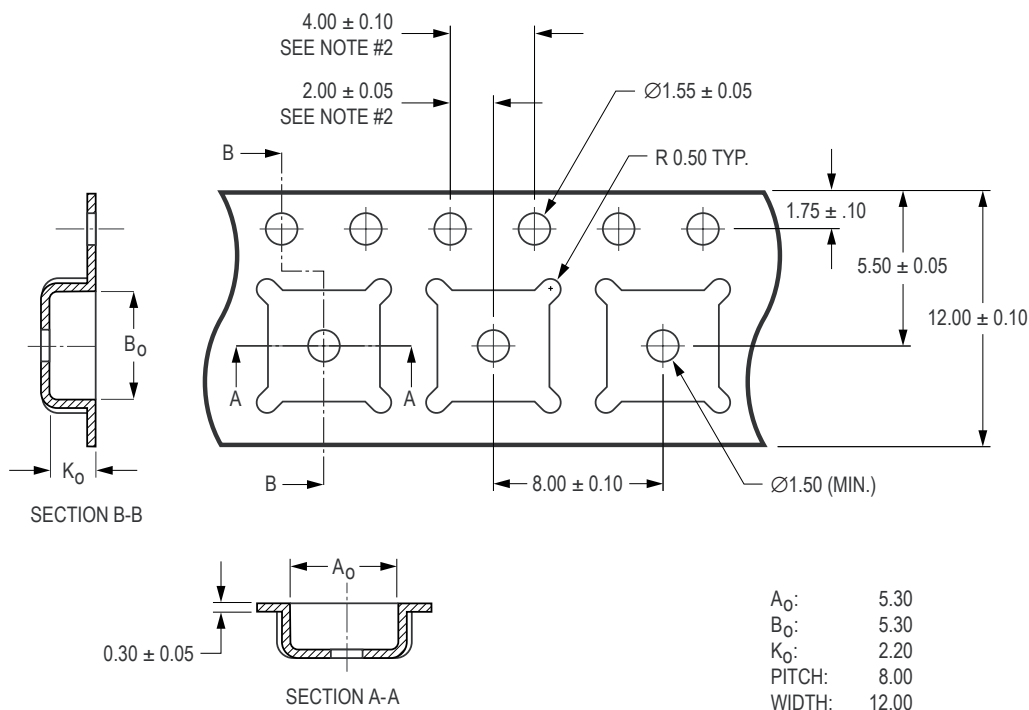

NOTES:

1. A₀ AND B₀ MEASURED AT 0.3 mm ABOVE BASE OF POCKET.
2. 10 PITCHES CUMULATIVE TOLERANCE IS ± 0.2 mm.
3. DIMENSIONS ARE IN MILLIMETERS (mm).

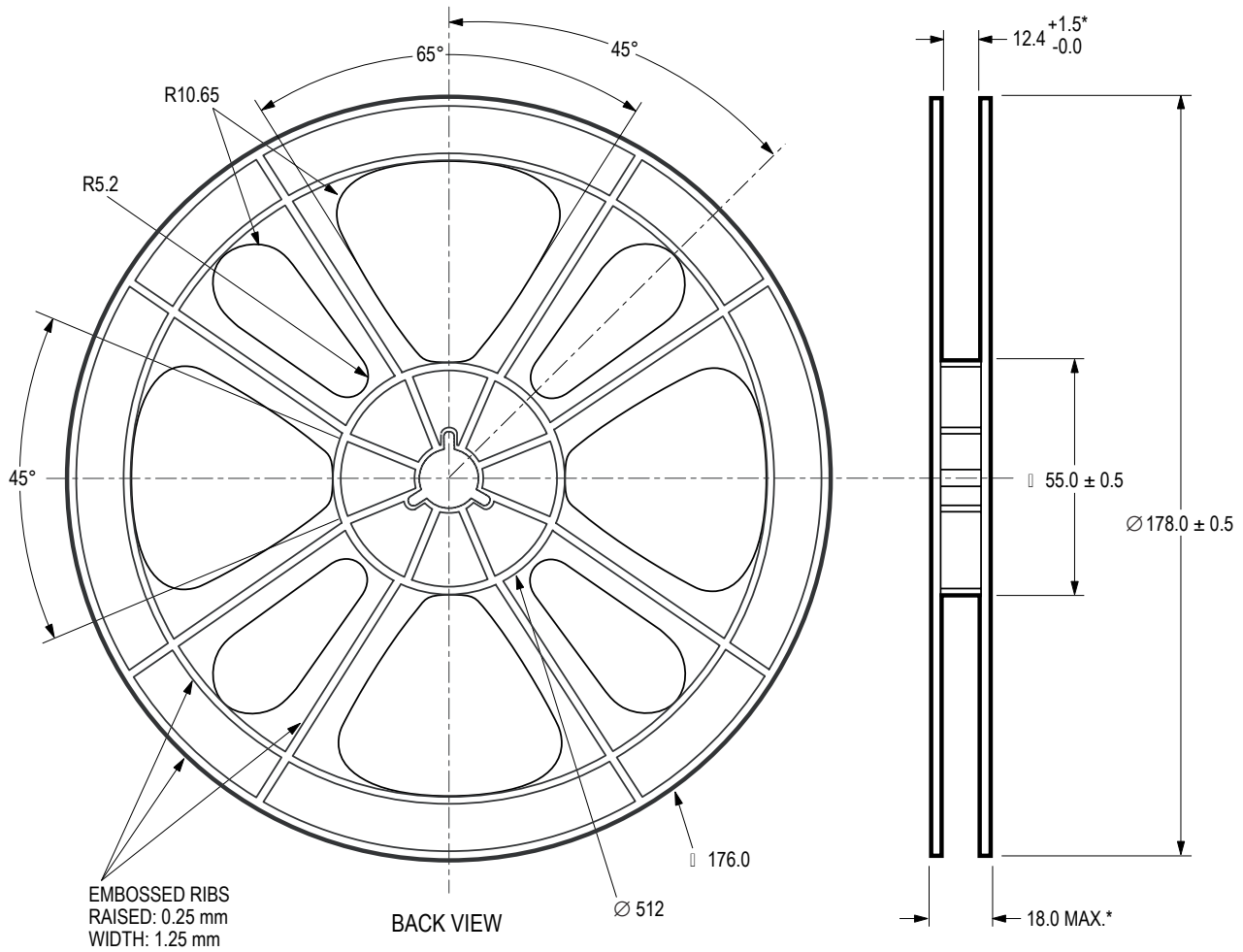

NOTES:

1. *MEASURED AT HUB AREA.
2. ALL FLANGE EDGES TO BE ROUNDED.

For product information and a complete list of distributors, please go to our web site: www.avagotech.com

Avago, Avago Technologies, and the A logo are trademarks of Avago Technologies, Limited in the United States and other countries. Data subject to change. Copyright © 2007 Avago Technologies Limited. All rights reserved.
AV02-0110EN - February 27, 2007

AVAGO
TECHNOLOGIES