



# FE-MLS8C/9C Series

## Long Range AC Sensors

- Harsh-duty polycarbonate housing
- DPDT Relay
- Gun sight for easy mechanical alignment

Photoelectric FE-MLS8C/9C Series Long Range

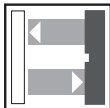

### Diffused Mode

See page 534

**Sensing Ranges:** 2.7m

**Outputs:** Relay

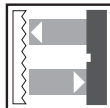

### Retro-Reflective Mode

See page 534

**Sensing Ranges:** 12m

**Outputs:** Relay



See pages 535-536 for FE-MLS8C/9C Series specifications, wiring and dimensions.



# Photoelectric Sensors



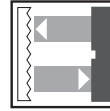

## Diffused Mode

Specifications	
SENSING RANGE	2.7m
SENSITIVITY ADJUSTMENT	No
MODEL NUMBER(S)	FE-MLS9C
OUTPUT	DPDT relay
SUPPLY VOLTAGE	102-132VAC
RESPONSE TIME	≤30ms
SWITCHING FREQUENCY	16Hz
APPROVALS	
  General Purpose	No
 General Purpose	No
ADDITIONAL DATA	See pages 535-536



## Retro-Reflective Mode

Specifications	
SENSING RANGE	12m
SENSITIVITY ADJUSTMENT	Yes
MODEL NUMBER(S)	FE-MLS8C
OUTPUT	DPDT relay
SUPPLY VOLTAGE	102-132VAC
RESPONSE TIME	≤20ms
SWITCHING FREQUENCY	25Hz
APPROVALS	
  General Purpose	Yes
 General Purpose	Yes
ADDITIONAL DATA	See pages 535-536

### Sensing Characteristics

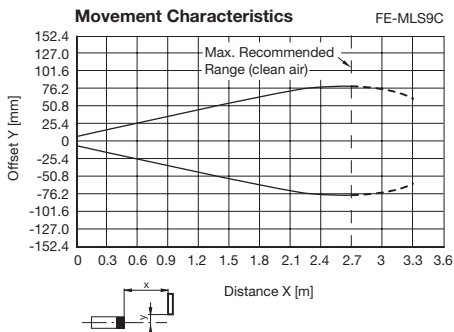
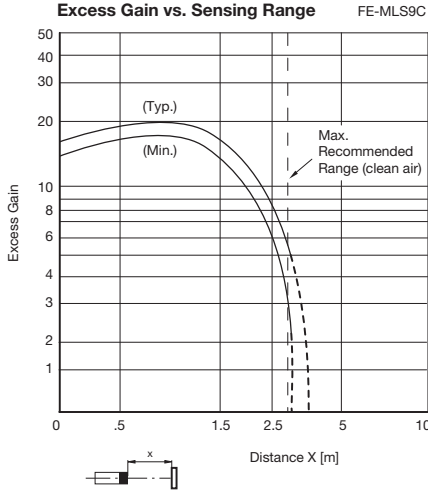

### Sensing Characteristics

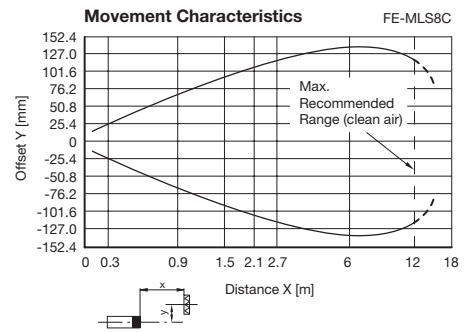
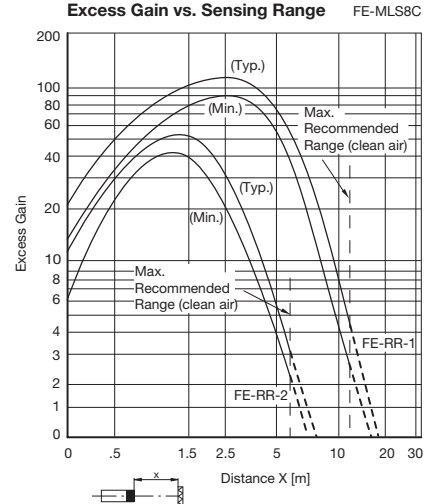

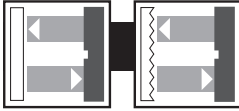

## Series Specifications

MLS8C/9C Series Specifications	
ELECTRICAL CONTACT RATING	115V/10A
LED(s)	Yes (1)
POWER CONSUMPTION	≤5VA
MECHANICAL LIFE OF RELAY	500,000 operations
OPERATING MODE	Light on/dark on
ELECTROMAGNETIC COMPATIBILITY COMPLIANCE	NEMA ICS5-2000 See page 6
PROTECTION (IEC)	IP67
LIGHT SOURCE	Infrared LED
TEMPERATURE RANGE	-40°F to +158°F
HOUSING MATERIAL	Glass reinforced polycarbonate
LENS	Plastic
ELECTRICAL CONNECTION	Terminal connection

### FE-MLS8C and FE-MLS9C Functional Block Diagram

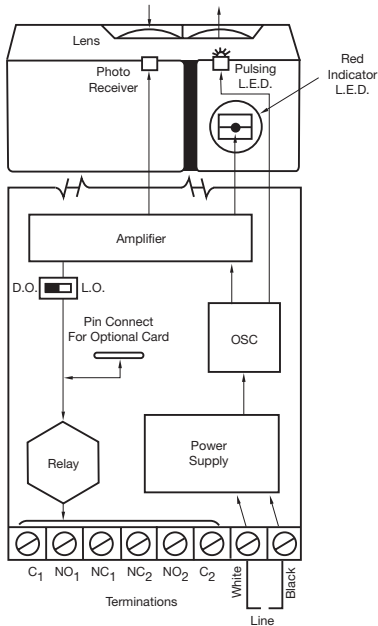

### FE-MLS8C Wiring and Alignment

- Remove the rear housing cover.
- Connect the load and load supply (common) to selected terminals. Standard relay connections shown below.

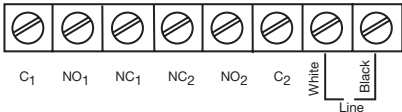

- Solid state relay connections shown below.

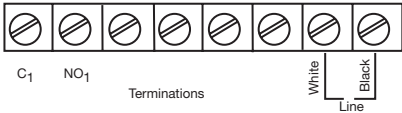

- Connect AC power (through the conduit opening) to the "LINE" terminals. The white and black input wires must be connected to the proper terminals. See the control nameplate for correct line voltage.
- Set the mode selector switch to the light operate (L.O.) position.
- Apply power. The alignment indicator light visible at the top of the control will remain OFF with no reflector present.

- Position the reflector opposite the lens. The indicator will turn On when control and reflector are in alignment.
- Center the reflector in the beam (by watching the indicator as the reflector is moved up, down, left and right). Use adhesive or a #8 screw (for the 3-inch disc) to mount the reflector.
- Block the invisible beam with the object to be detected. When the beam is blocked, the indicator will be Off.
- Fully tighten the mounting bolts, and again block the beam to recheck alignment.
- If direct On-Off dark operation is desired (relay energized when the beam is blocked), move the mode selector switch to the dark operate (D.O.) position.
- Insert optional function card firmly (if used) and adjust pots as required.
- Replace cover and tighten both screws.

Photoelectric FE-MLS8C/9C Series Long Range

# Photoelectric Sensors

## FE-MLS9C Wiring and Alignment

- Remove the rear housing cover.
- Connect the load and load supply (common) to selected terminals. Standard relay connections shown below.

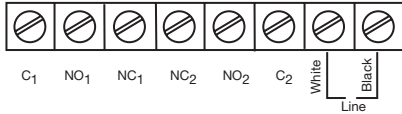

- Solid state relay connections shown below.

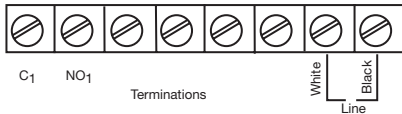

- Connect AC power (through the conduit opening) to the "LINE" terminals. The white and black input wires must be connected to the proper terminals. See the control nameplate for correct line voltage.
- Set the mode selector switch to the light operate (L.O.) position.
- Apply power. The alignment indicator light visible at the top of the control will remain OFF with no reflector present.

- Position the reflector opposite the lens. The indicator will turn On when control and reflector are in alignment.
- Center the reflector in the beam (by watching the indicator as the reflector is moved up, down, left and right). Use adhesive or a #8 screw (for the 3-inch disc) to mount the reflector.
- Block the invisible beam with the object to be detected. When the beam is blocked, the indicator will be Off.
- Fully tighten the mounting bolts, and again block the beam to recheck alignment.
- If direct On-Off dark operation is desired (relay energized when the beam is blocked), move the mode selector switch to the dark operate (D.O.) position.
- Insert optional function card firmly (if used) and adjust pots as required.
- Replace cover and tighten both screws.

## Dimensions (mm)

### FE-MLS8C and FE-MLS9C Sensors

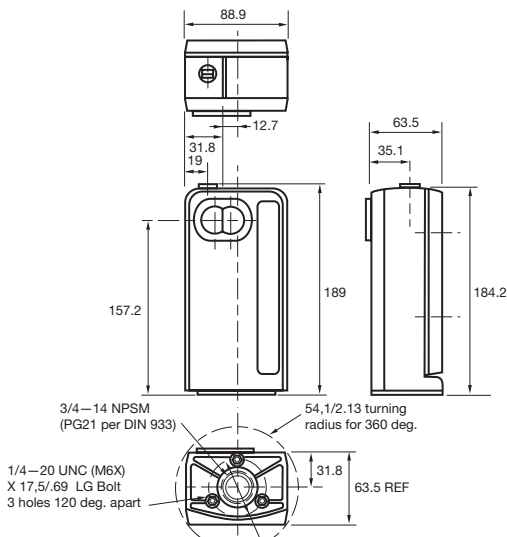

## Accessories

(Dimensions in mm)

### Mounting Bracket Model FE-MB8

