



SUR CONNECTOR

Disconnectable Insulation displacement connectors

JST

IDC

0.8mm
(.031") pitch

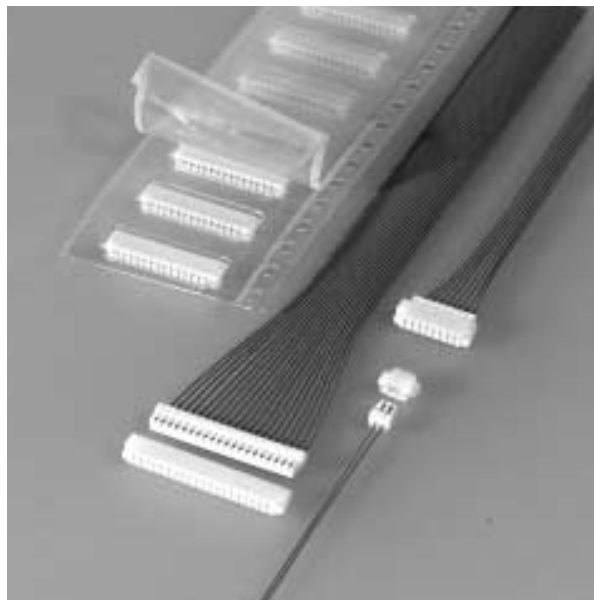

The world's first 0.8mm (.031") pitch wire-to-board insulation displacement connector. Only 3.9mm (.154") depth and 1.75mm (.069") height after mounting on the PC board. Compared to the conventional 1.0mm (.039") pitch SSR connector, occupation space on the board is reduced by 34%.

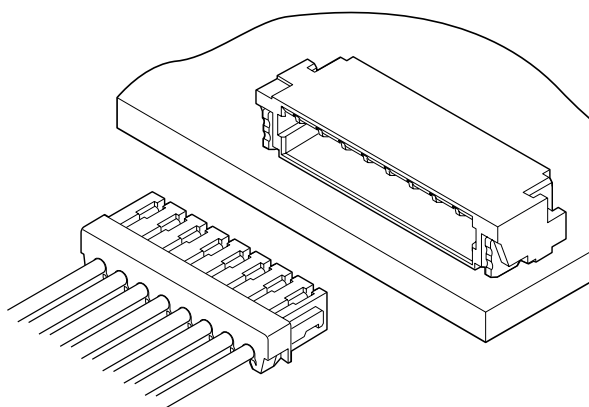

Features

• 3-point grip construction

The 3-point insulation grip feature and the strain relief ensure a firm grip on terminated wires and protection of the insulation displacement connection from possible damage.

• Super fine wires are applicable

Applicable wire is of AWG #32 with only 0.38mm (.015") O.D. With this super fine wire, routing of wires is easy."

• Shrouded header

The header is fully shrouded, but remains thin.

• Twin U-slot insulation displacement section

The insulation displacement section connected to each wire consists of two tin-plated slots (twin U-slots), which ensures reliable connection.

Specifications

- Current rating: 0.5A AC, DC (AWG #32)
- Voltage rating: 30V DC
- Temperature range: -25°C to +85°C (including temperature rise in applying electrical current)
- Contact resistance: Initial value/20m Ω max.
After environmental testing/40m Ω max.
- Insulation resistance: 100M Ω min.
- Withstanding voltage: 200V AC/minute
- Applicable wire: AWG #32
Conductor/7 strands,
tin-coated copper alloy
Insulation O.D./0.38mm (.015")

* Contact JST for details.

Receptacle

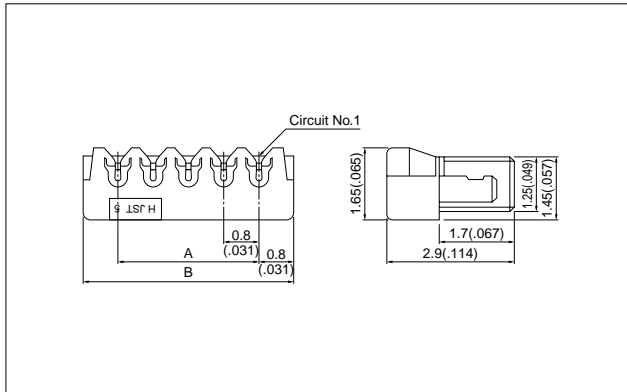

Circuits	Model No.	Dimensions mm(in.)		Qty/box
		A	B	
2	02SUR-32S	0.8(.031)	2.4(.094)	2,000
4	04SUR-32S	2.4(.094)	4.0(.157)	2,000
8	08SUR-32S	5.6(.220)	7.2(.283)	2,000
14	14SUR-32S	10.4(.409)	12.0(.472)	2,000
15	15SUR-32S	11.2(.441)	12.8(.504)	2,000
16	16SUR-32S	12.0(.472)	13.6(.535)	2,000
17	17SUR-32S	12.8(.504)	14.4(.567)	2,000
20	20SUR-32S	15.2(.598)	16.8(.661)	2,000

Material and Finish

Contact: Copper alloy, tin-plated
Housing: Polyamide, UL94V-0, natural (ivory)

Shrouded header

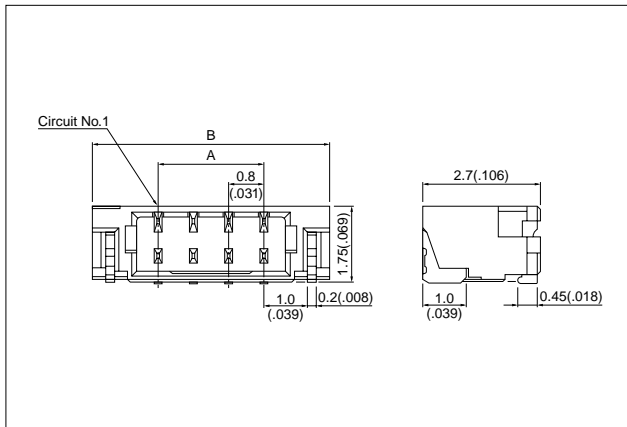

Circuits	Model No.	Dimensions mm(in.)		Qty/ reel
		A	B	
2	SM02B-SURS-TF	0.8(.031)	3.8(.150)	3,500
4	SM04B-SURS-TF	2.4(.094)	5.4(.213)	3,500
8	SM08B-SURS-TF	5.6(.220)	8.6(.339)	3,500
14	SM14B-SURS-TF	10.4(.409)	13.4(.528)	3,500
15	SM15B-SURS-TF	11.2(.441)	14.2(.559)	3,500
16	SM16B-SURS-TF	12.0(.472)	15.0(.591)	3,500
17	SM17B-SURS-TF	12.8(.504)	15.8(.622)	3,500
20	SM20B-SURS-TF	15.2(.598)	18.2(.717)	3,500

Material and Finish

Contact: Copper alloy, copper-undercoated, tin/lead plated
Wafer: Polyamide, UL94V-0, natural (ivory)
Solder tab: Brass, copper-undercoated, tin/lead plated

Note: The products listed above are supplied on embossed-tape.

PC board layout (viewed from component side) and Assembly layout

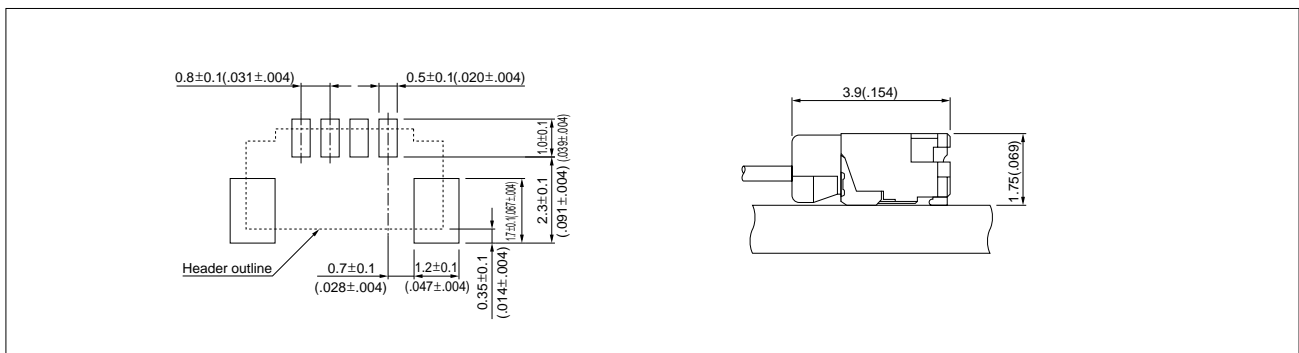

Note: 1. Tolerances are non-cumulative: $\pm 0.05\text{mm} (\pm .002")$ for all centers.
2. Dimensions above should serve as a guideline. Contact JST for details.

SUR CONNECTOR

Taping specifications

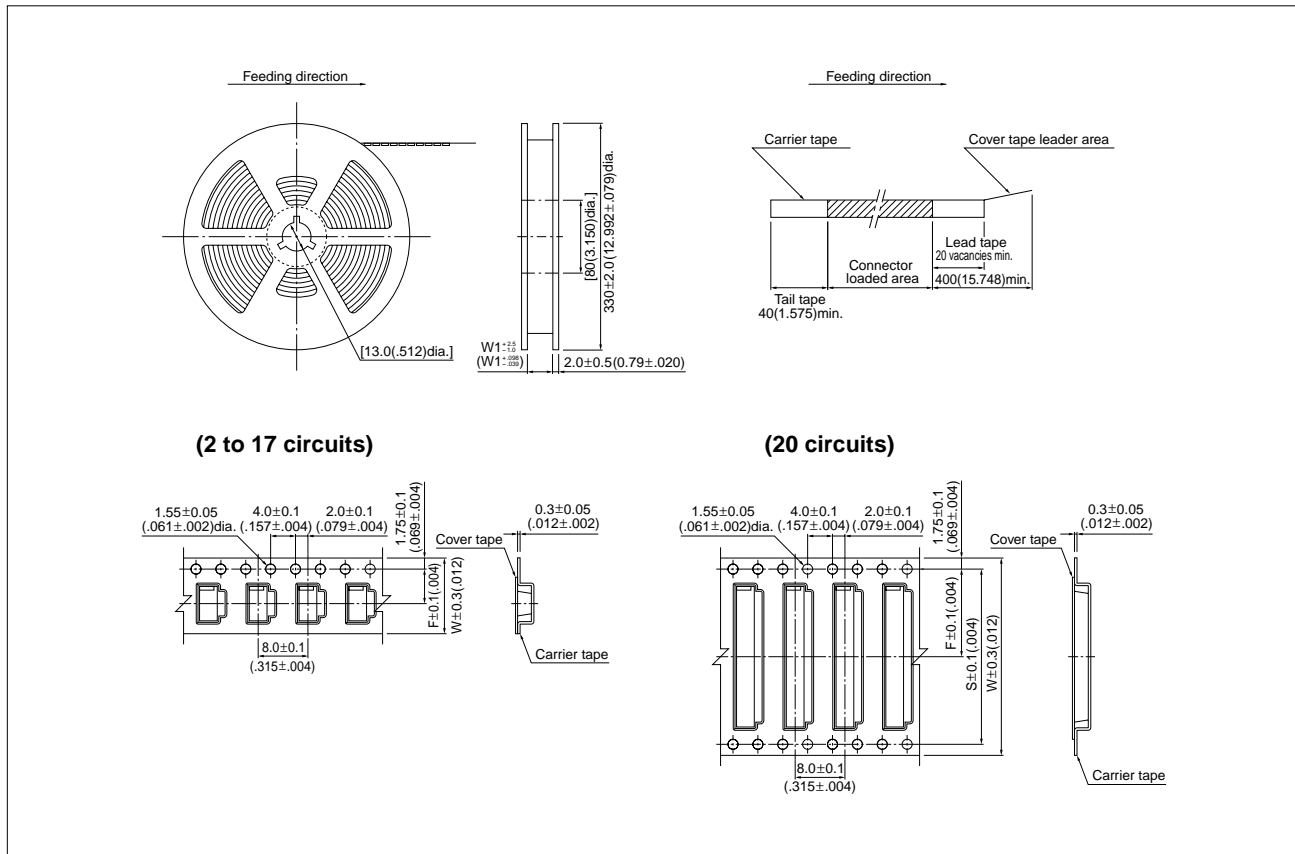

Cir- cuits	Taping dimensions mm(in.)			Reel dimensions mm(in.)	Q'ty / reel
	F	S	W	W1	
2,4	5.5(.217)	—	12(.472)	13.5(.531)	3,500
8	7.5(.295)	—	16(.630)	17.5(.689)	3,500
14 to 17	11.5(.453)	—	24(.945)	25.5(1.004)	3,500
20	14.2(.559)	28.4(1.118)	32(1.260)	33.5(1.319)	3,500

Note:

- Specifications conform to JIS C 0806. The tape width, connector recess hole dimensions, etc. are determined by the number of circuits and external shape of the connector to be loaded.
- Specifications are subject to change without prior notice.