

DATE	DESCRIPTION	REV.
6.27.08	CHANGE AS PER ECN 08-115	A
12.08.08	CHANGE AS PER ECN 08-186	B
12.14.09	CHANGE AS PER ECN 09-184	C

MOUNTING LAYOUT

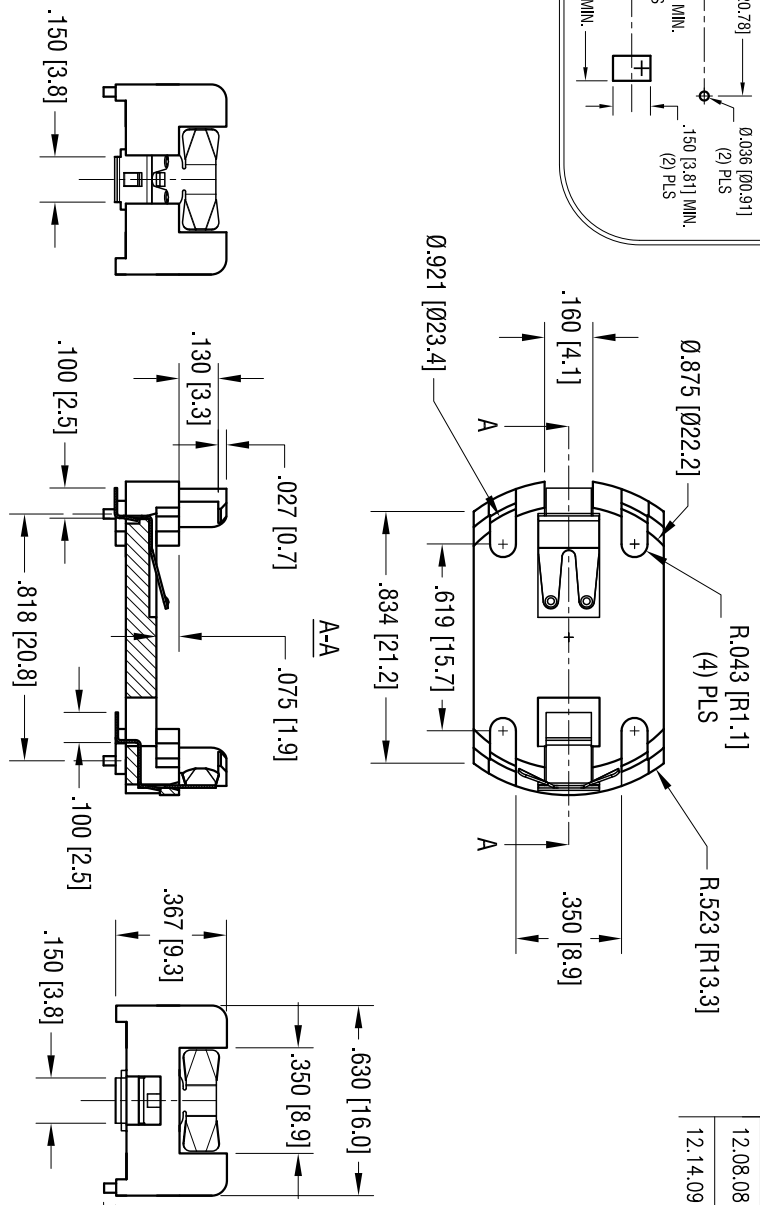
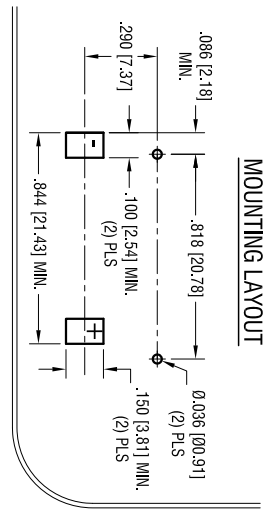

- NOTE:**
1. BASE MAT'L - HIGH TEMPERATURE NYLON, UL94V-0
 2. CONTACTS:
 MAT'L - .008 [0.20] THK PHOSPHOR BRONZE
 FINISH - GOLD FLASH, OVER NICKEL PLATE

THIS DOCUMENT IS THE PROPERTY OF KEYSTONE ELECTRONICS CORP. AND SHALL NOT BE REPRODUCED, DISTRIBUTED OR COPIED IN ANY MANNER WITHOUT WRITTEN PERMISSION FROM KEYSTONE ELECTRONICS CORP.

KEYSTONE ELECTRONICS CORP.			
www.keystonem.com • ASTORIA, N.Y. 11105-2017 • Tel (718) 956-8900			
PART NAME		2450 SMT BATTERY HOLDER	
MATERIAL		AS NOTED	
FINISH	AS NOTED	DRN BY	NT
DATE	6.09.09	APPD	SCALE
2X			
TOLEBRANGES	INCH	CODE	DWG NO.
DECIMAL	± .005 [± 0.15]	C	1054
ANGULAR	± 1°		
UNLESS OTHERWISE SPECIFIED.			