



ALL RIGHTS RESERVED. NO PORTION OF THIS PUBLICATION, WHETHER IN WHOLE OR IN PART CAN BE REPRODUCED WITHOUT THE EXPRESS WRITTEN CONSENT OF SPC TECHNOLOGY.

SPC-F005.DWG

REVISIONS

DOC. NO. SPC-F005 * Effective: 7/8/02 * DCP No: 1398

DCP #	REV	DESCRIPTION	DRAWN	DATE	CHECKD	DATE	APPRVD	DATE
1906	A	RELEASED	EO	04/17/06	TL	05/25/06	HO	05/25/06

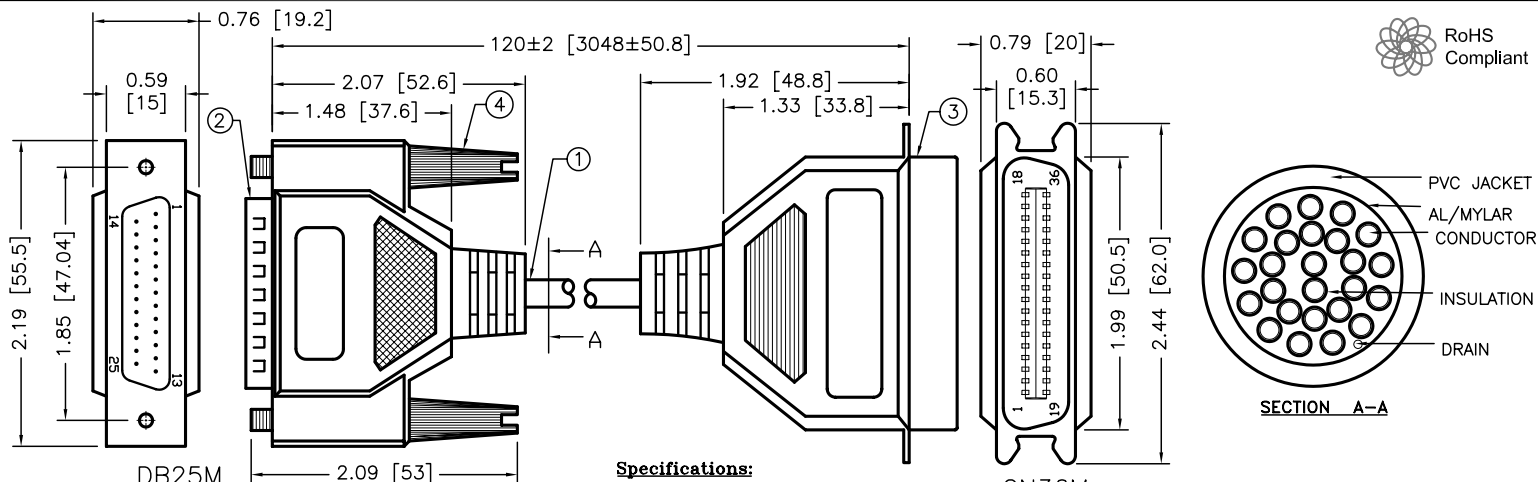

Specifications:

- Molded connector end requirements:
 - Inner mold using PE
 - Aluminum foil wrap to connector
 - PVC - 45P, Platinum gray
- Cable:
 - 28AWG (7/0.12)*25C+AL/MY
 - Wire: OD=0.78±0.03mm
 - Jacket: PVC OD=7.0±0.15mm
 - Color: Platinum gray

PIN OUTS

DB25 MALE	WIRE COLOR	C36 MALE	DB25 MALE	WIRE COLOR	C36 MALE	DB25 MALE	WIRE COLOR	C36 MALE
1	BLACK	1	10	GRAY	10	19	LIGHT-GREEN	19
2	BROWN	2	11	BLACK/WHITE	11	20	PINK	20
3	RED	3	12	BROWN/WHITE	12	21	PINK/BLACK	21
4	ORANGE	4	13	RED./WHITE	13	22	GRAY/BLACK	22
5	YELLOW	5	14	ORANGE/WHITE	14	23	ORANGE/BLACK	23
6	GREEN	6	15	YELLOW/BLACK	32	24	RED/BLACK	24
7	BLUE	7	16	GREEN/WHITE	31	25	GREEN/BLACK	25
8	PURPLE	8	17	BLUE/WHITE	36	Shell	Shell	Shell
9	WHITE	9	18	PURPLE/WHITE	16			

ITEM NO	PART NAMES	Q'TY
④	THUMBSCREW: MALE 4*47mm NICKEL-PLATING	2PCS
③	CONNECTOR:CN36P MALE NICKEL-PLATING, INSULATOR COLOR:BLUE	1PCS
②	CONNECTOR:DB25P MALE NICKEL-PLATING, INSULATOR COLOR:BLUE	1PCS
①	CABLE:25C+1 28AWG	1PCS
INSULATION: UPON 1M ohm AND 1M ohm		ELECTRIC CONDUCTION:INSIDE 1.5K ohm

DISCLAIMER:
ALL STATEMENTS AND TECHNICAL INFORMATION CONTAINED HEREIN ARE BASED UPON INFORMATION AND/OR TESTS WE BELIEVE TO BE ACCURATE AND RELIABLE. SINCE CONDITIONS OF USE ARE BEYOND OUR CONTROL, THE USER SHALL DETERMINE THE SUITABILITY OF THE PRODUCT FOR THE INTENDED USE AND ASSUME ALL RISK AND LIABILITY WHATSOEVER IN CONNECTION THEREWITH.

TOLERANCES:
UNLESS OTHERWISE SPECIFIED, DIMENSIONS ARE FOR REFERENCE PURPOSES ONLY.

DRAWN BY:	DATE:	DRAWING TITLE:
EKLAS ODISH	04/17/06	10 FT PRINTER CABLE, DB25 PIN MALE/CN36 PIN MALE
CHECKED BY:	DATE:	SIZE DWG. NO.
THOMAS LEE	05/25/06	A SPC20024
APPROVED BY:	DATE:	ELECTRONIC FILE
HISHAM ODISH	05/25/06	83K3755.DWG
		REV
		A

SCALE: NTS	U.O.M.: INCHES [mm]	SHEET: 1 OF 1
------------	---------------------	---------------