

Optical Liquid Level Sensors D102 Series

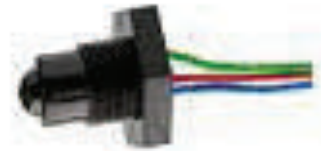

- Features:
- * M12 Screw-in Body
 - * Low cost
 - * Compact size
 - * Wide range of commercial and industrial applications.



	Standard Temperature	High Temperature
Housing	D102 M12 Threaded Probe	
Output Function	Digital - High in Air	
Repeatability	± 1 mm	
Hysteresis	2mm (depending on liquid)	
Response Time: Rising Liquid	50 µS	
Response Time: Falling Liquid (Ethanol)	< 1 second	
Supply Voltage	+5V to 12VDC	
Supply Current	15 mA	
Temperature Range: Operating / (Storage)	-25°C to +80°C (-30°C to +85°)	-40°C to +125°C (-40°C to +125°C)
Housing Material	Polysulphone	
Output Current (@25°C & 5VDC)	Sinks 10 mA	Sinks 40 mA
Lead wire Length	250mm PTFE	

Order Codes:

- D102000 Standard Temperature Range ⁽¹⁾
 D102101 Extended Temperature Range ⁽²⁾

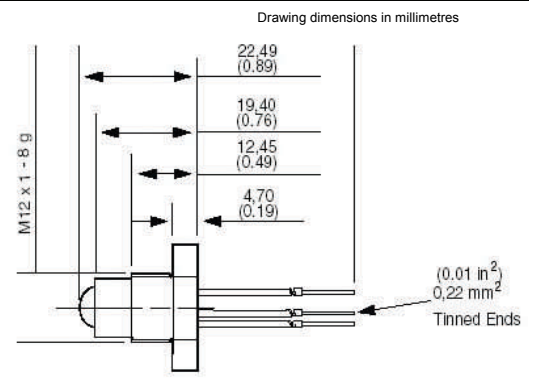
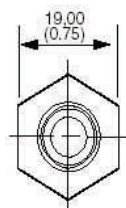
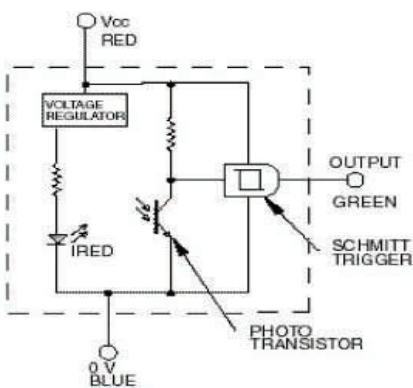

Recommended panel hole size is 12.5mm +/- 0.3mm. (0.49 +/- in)

- (1) Supplied with Nitrile washer and nut, unassembled.
 (2) Supplied with VAMAC washer and nut, unassembled.
 Contact factory for custom terminations and other lead lengths available to special order.



© American Electronic Components Inc 2008

American Electronic Components Inc.,
 1101 Lafayette Street, Elkhart, Indiana, USA
 Tel: +1-574-295-6330 Fax: +1-574-293-8013
 Email: sales@aecensors.com
<http://www.aecensors.com>