

FS-550 Series – High Pressure, Metal Paddle Switch

Pipe Line Size: 1-1/4" and Up
Primary Construction Material: Stainless Steel or Brass
Setting Type: Fixed

Standard FS-550 switches sense liquid flow in either direction to monitor flow/no-flow conditions. They are supplied in two paddle lengths. The paddle is trimmed during installation to permit switch actuation at the desired flow rate. As flow increases in a pipe, the paddle of the switch pivots to move out of the liquid path, producing less than 3 PSIG of pressure drop regardless of pipe size.

Specifications

Wetted Materials	
Housing	Brass or 316 Stainless Steel
Paddle	302 Stainless Steel
Spring	316 Stainless Steel
Other Wetted Parts	Ceramic and Teflon®
Operating Pressure, Maximum	2000 PSIG (138 bar)
Pressure Drop	3 PSIG (0.2 bar) Maximum
Operating Temperature	-30°F to + 300°F (-34.4°C to + 148.9°C)
Set Point Accuracy	± 25%
Switch*	SPDT, 20 VA
Repeatability	± 5%
Electrical Termination	No. 18 AWG, 24" L., Polymeric Lead Wires

* See "Electrical Data" on Page X-5 for more information.

Standard Actuation and De-actuation Set Points

The Table below indicates paddle lengths which achieve switch actuation for specific flow rates. Approximate pipe line sizes are marked on paddle.

	Pipe Size Marked at Paddle Cut-Off Point	Pipe Line Sizes					
		1-1/4"	1-1/2"	2"	2-1/2"	3"	4"
		Approximate Actuation and (De-Actuation) Flow Rates GPM Water					
Short Paddle Unit	1-1/4"	5 (3)	13 (8)	22 (15)	29 (22)	—	—
Long Paddle Unit	1-1/2"	—	15 (11)	28 (21)	38 (30)	—	—
	2"	—	—	22 (15)	27 (20)	48 (38)	—
	2-1/2"	—	—	—	21 (14)	40 (26)	52 (39)
	3"	—	—	—	—	31 (20)	45 (32)
	4"	—	—	—	—	—	39 (25)

All flow rate tests for the above table were conducted with the switch installed in a standard "T" fitting. For calculation of flow rates in pipe sizes larger than 5", a flow velocity of approximately 0.5 ft. per sec. actuates the switch with a full length (5") paddle. The paddle can be trimmed to achieve different actuation points.

How To Order – Standard Models

Select switch type, paddle length and housing material, then specify adjacent part number.

Switch Type	Paddle Length	Housing Material	Switch Operation	Part Numbers	
				Standard	3-Pin J-Box
SPDT Standard Unit	Long	Brass	N.O. or N.C.	29609	56730
		316 S.S.		29608	56729
	Short	Brass		30641	66914
		316 S.S.		30640	61189

Note: The FS-550 Switch is not recommended for use with 1" plastic tees.



U.L. Recognized
 File No. E31926
 CSA Listed —
 File No. LR30200
 and LR22666
 FM Approved —
 File No. 0A8A3.AE
 and 1H3A2.AX

Dimensions

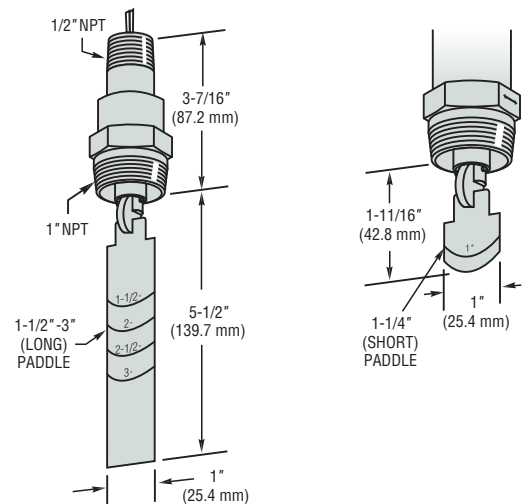

FS-550 switches are U.L. Approved for Class I, Division 2, Groups A, B, C, D hazardous areas.

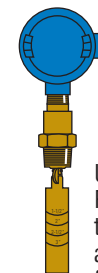

They are also available as FM-approved when used with GEMS Junction Boxes which are explosion-proof for Class I, Division 1, Groups B, C, D, E, F, G hazardous locations.

Using GEMS SAFE-PAK Relays and barriers, these switches provide automatic flow/no flow interlock and are intrinsically-safe without explosion-proof housing and piping.

U.L. Approved — File No. E183854

