



Flow Sens FS5L / FS5LA

Thermal Mass Flow Sensor for all-purpose use in Liquids

All mechanical dimensions are valid at 25°C ambient temperature, if not differently indicated. ■ All data except the mechanical dimensions only have information purposes and are not to be understood as assured characteristics. ■ Technical changes without previous announcement as well as mistakes reserve. ■ The information on this data sheet was examined carefully and will be accepted as correct. No liability in case of mistakes. ■ Load with extreme values during a longer period can affect the reliability.

Product

The Flow Sens owns for water and water mixtures optimized design consists of two temperature depending platinum-resistors, both deposited on one chip. The low-ohm resistor with a small area is used as a heater, whereas the other high-ohm resistor serves to measure the reference temperature. Using a bridge circuit, the differing resistance value of two elements leads to different (self) heating. The (self) heating is dependent upon the applied voltage, the mass flow, and the media in which the sensor is located. Higher voltage increases self heating, a higher flow rate increases cooling. If the self heating is kept constantly by a suitable controller, the voltage increases with higher flow rates and therefore becomes a measure for the mass flow. As a result of his little thermal mass, this sensor has fast heating and cooling response times. The measuring principle of the sensor can be used for large operation ranges. The Flow Sens is also available with a plastic housing of Ø 6mm. This option provides the user with ideal opportunities to incorporate the element into custom-built applications or specific housings, e.g. into a T-piece.

Advantages

- Easy adaptable for different applications or into housings
- Simple signal processing and calibration
- No moving parts
- Excellent reproducibility
- Excellent long -term stability
- Best price-performance ratio

Applications

- HVAC and building control solutions
- Automotive industry
- Medical devices
- Device monitoring
- Cooling devices
- Food industry



INNOVATIVE SENSOR TECHNOLOGY

IST AG, Industriestrasse 2, CH-9630 Wattwil, Switzerland, Phone (+)41 71 987 73 73, Fax (+)41 71 987 73 77
e-mail info@ist-ag.com, www.ist-ag.com



Flow Sens FS5L / FS5LA

Thermal Mass Flow Sensor for all-purpose use in Liquids

Technical Data

Measuring principle	thermal
Measuring range	0 ... 10 m/s
Response sensitivity	0.01m/s
Accuracy	< 3% current measuring value (dependent on electronic and calibration)
Warm up time	< 1 min (depending on mounting)
Response time $t_{63\%}$	< 100 ms
Temperature range	-30 ... + 100 °C (150°C)
Electrical connection	3 pins, NiPt- Leads – 0,2mm , insulated with PTFE- tube
Heater	$R_H(0^\circ\text{C}) = 45 \Omega \pm 1\%$
Referenz element	$R_S(0^\circ\text{C}) = 1200 \Omega \pm 1\%$
Required Voltages	typical 4 - 10 V (bridge supply voltage) at $\Delta T = 10 \text{ K}$, $0 \leq V_{\text{ström}} \leq 10 \text{ m/s}$
Max. heater voltage @ 0m/s	6 V
Substrate material	Al ₂ O ₃ ceramic

In general Other media and higher requirements upon request.
No responsibility accepted.

Construction size

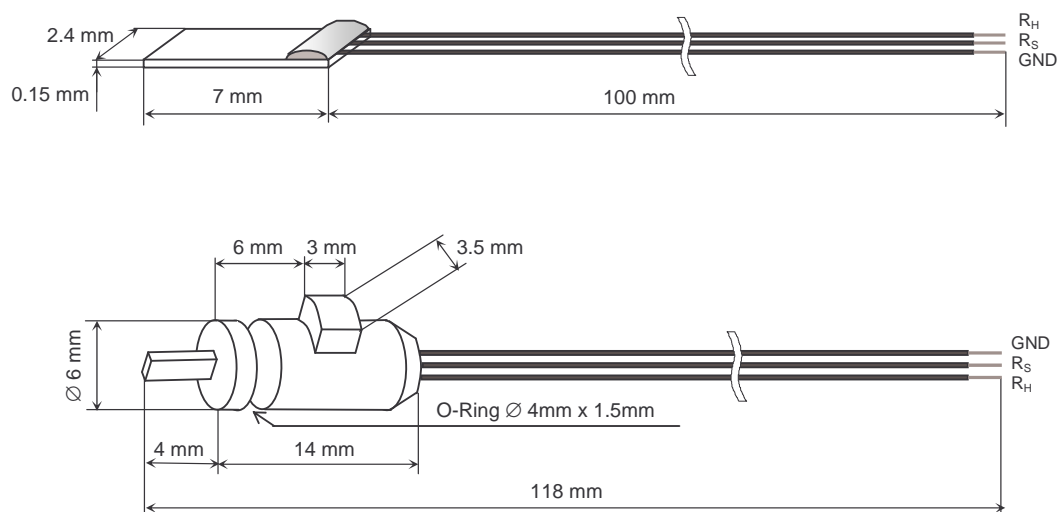

INNOVATIVE SENSOR TECHNOLOGY

ISTAG, Industriestrasse 2, CH-9630 Wattwil, Switzerland, Phone (+)41 71 987 73 73, Fax (+)41 71 987 73 77
e-mail info@ist-ag.com, www.ist-ag.com

All mechanical dimensions are valid at 25°C ambient temperature, if not differently indicated. ■ All data except the mechanical dimensions only have information purposes and are not to be understood as assured characteristics. ■ Technical changes without previous announcement as well as mistakes reserve. ■ The information on this data sheet was examined carefully and will be accepted as correct; No liability in case of mistakes. ■ Load with extreme values during a longer period can affect the reliability.



Flow Sens FS5L / FS5LA

Thermal Mass Flow Sensor for all-purpose use in Liquids

Electronic circuit recommendation CTA (Constant temperature anemometer)

The two elements (heaters RH and sensor Rs) can be interconnected in accordance with following schematic in a bridge. Resistances R1, R2 and R3 are to be dimensioned correctly according sample circuit to be seen below. The bridge is balanced, if the temperature difference (ΔT) amounts the desired value between Rs and RH of e.g. 10 K. With changing flow rate the bridge supply voltage U_{Bs} changes. The values for R1 and R3 depend on the temperature difference ΔT and the medium which can be measured. They are delivered the customer. For air or other gases can be taken this from following circuit suggestion. R2 should be able to be adjusted for the purpose of the calibration about 10%. The alignment procedure depends on application.

Both circuit and the curve plotting are examples. In the concrete case of application always an individual calibration is necessary.

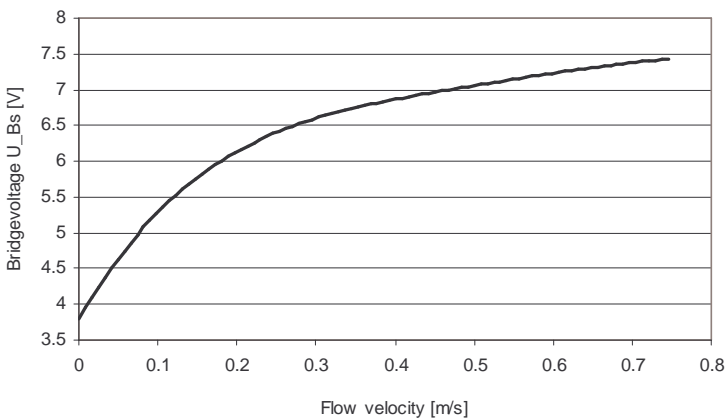

Typical signal – curve between 0 0.8 m/s

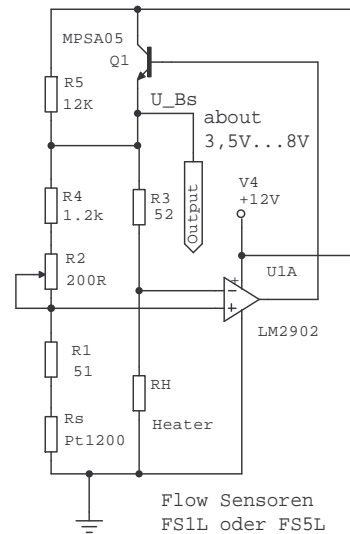

Flow Sensoren FS1L oder FS5L

Option

The electric connection can be provided customer-specific.

If a connector is requested we provide e.g. the JST connector EHR-3 with 3 pins, polarized and with a latch locking system.

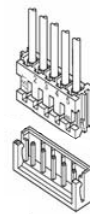

INNOVATIVE SENSOR TECHNOLOGY



IST AG, Industriestrasse 2, CH-9630 Wattwil, Switzerland, Phone (+)41 71 987 73 73, Fax (+)41 71 987 73 77
e-mail info@ist-ag.com, www.ist-ag.com

All mechanical dimensions are valid at 25°C ambient temperature, if not differently indicated. ■ All data except the mechanical dimensions only have information purposes and are not to be understood as assured characteristics. ■ Technical changes without previous announcement as well as mistakes reserve. ■ The information on this data sheet was examined carefully and will be accepted as correct; No liability in case of mistakes. ■ Load with extreme values during a longer period can affect the reliability.

All rights reserved. The material contained herein may not be reproduced, adapted, merged, translated, stored, or used without the prior written consent of the copyright owner. Typing errors and mistakes reserved. Product specifications are subject to change without notice.

V2.0-04/2005