

Incremental Encoders



Incremental encoders are sensors capable of **generating signals** in response to rotary movement. In conjunction with mechanical conversion devices, such as rack-and-pinions, measuring wheels or spindles, incremental shaft encoders can also be used to measure **linear movement**. The shaft encoder generates a signal for each incremental change in position.

With the **optical transformation**, a line-coded disc made of metal, plastic or glass and positioned on a rotary bearing interrupts the infra red light ray emitted by gallium arsenid sender diode. The number of lines determines the resolution, i.e. the measuring points within a revolution. The interruptions of the light ray are sensed by the receptor element and electronically processed. The information is then made available as a rectangular signal at the encoder output.

Examples for typical applications of incremental encoders:

- Franking machines
- Door closing devices for trains
- Desktop robots
- Lens grinding machines
- Plotters
- Testing machines for optical waveguides
- Scattering machines
- Tampon printing machines
- Ultrasonic welding
- Screwing machines
- Labelling machines
- x/y indication
- Analysis devices
- Drilling machines
- Mixing machines

Incremental Encoders



Type	RI 30	RI 36
Special features	<ul style="list-style-type: none"> ■ small encoder for industrial applications ■ low power consumption ■ high immunity to interference ■ cable lengths up to 100 m ■ suitable for high pulse frequencies ■ high level of protection ■ applications, e.g. CNC machine centers, handling systems, motors, medical technology, textile machinery 	<ul style="list-style-type: none"> ■ small industrial encoder for high numbers of pulses ■ high operating safety ■ applications, e.g. CNC axles, machine tools, robots, special machinery, high-speed winding machines
Number of pulses	5 ... 1,500	5 ... 3,600
Technical Data - mechanical		
Flange	S = synchro flange, R = round flange	S = synchro flange, R = round flange
Shaft diameter	5 mm	6 mm/6,35 mm
Absolute max. shaft load radial/axial	30 N/15 N (6.5/3.3 lbs)	30 N/15 N (6.5/3.3 lbs)
Absolute max. speed	10,000 RPM	10,000 RPM
Torque	≤ 0.2 Ncm	≤ 0.3 Ncm
Protection class Housing/Bearing	IP 64/64	IP 64/64
General design	as per DIN VDE 0160, protection class III	as per DIN VDE 0160, protection class III
Operating temperature	-10...+70 °C	-10...+70 °C
Connection	Cable axial/radial	Cable or connector axial/radial
Size	Ø 30 mm	Ø 36 mm
Weight	60 g approx.	80 g approx.
Technical data - electrical		
Output	RS 422/push-pull	RS 422/push-pull
Supply voltage (SELV)	5 VDC/10...30 VDC	5 VDC/10...30 VDC
Max. intrinsic power consumption	40 mA (5 VDC), 30 mA (24 VDC), 60 mA (10 VDC)	40 mA (5 VDC), 30 mA (24 VDC), 60 mA (10 VDC)
Max. pulse frequency	300 kHz (RS 422) 200 kHz (push-pull))	300 kHz (RS 422) 200 kHz (push-pull))
Output load	RS 422: ± 30 mA push-pull with short circuit protection: 30 mA (10...30 VDC)	RS 422: ± 30 mA push-pull with short circuit protection: 30 mA (10...30 VDC)
Alarm output	NPN-O.C. 5 mA	NPN-O.C. 5 mA
Pulse shape		
Pulse duty factor	1 : 1	1 : 1
Pulse width error	± max. 25° electrical	± max. 25° electrical
Page	61	65

Incremental Encoders

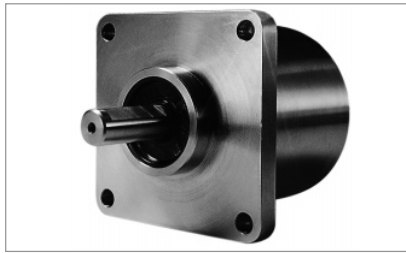

RI 58	RI 59	RX 70-TI
<ul style="list-style-type: none"> ■ universal industrial encoder ■ up to 40,000 steps with 10,000 pulses ■ high signal accuracy ■ protection class up to IP 67 ■ operating temperature up to 100°C ■ flexible due to many flange and connector variants ■ suitable for high shock loads ■ applications e.g. machine tools, CNC axes, packaging machinery, motors, drives, injection moulding machines, sawing machines, textile machinery 	<ul style="list-style-type: none"> ■ stainless steel encoder with high degree of protection ■ high corrosion resistance ■ suitable for use in food production ■ applications e.g. packaging machinery, filling plants, washing systems, mixing machines 	<ul style="list-style-type: none"> ■ explosion-proof according to class II of EEX d IIC T6/T4 ■ highest operating safety ■ applications e.g. lacquering lines, surface processing machines, filling plants, mixing machines, silo systems
1 ... 10,000	1 ... 10,000	1 ... 10,000
S = synchro flange, K = clamping flange, G, Q = square flange, M = synchro clamping flange	Q = square flange	K = clamping flange
6 mm/6.35 mm/7 mm/10 mm/9.52 mm/12 mm	9.52 mm/10 mm	10 mm
<ul style="list-style-type: none"> Ø 12 mm - 180/140 N (39/30 lbs) Ø 7 ... 10 mm - 160/107 N (35/24 lbs) Ø 6 mm/6,35 mm - 110/60 N (24/13 lbs) 	160/107 N (35/24 lbs)	160/107 N (35/24 lbs)
10,000 RPM	10,000 RPM	6,000 RPM (T6), 10,000 RPM (T4)
≤ 0.5 Ncm	≤ 0.5 Ncm	≤ 0.5 Ncm
65/64, 67/67	IP 67/67	IP 65/64
as per DIN VDE 0160, protection class III	as per DIN VDE 0160, protection class III	as per DIN VDE 0160, protection class III
RI 58-O: -10...+70 °C/RI 58-T: -25...+100 °C	-10...+ 70 °C	-10...+ 40 °C (T6), -20...+60 °C (T4)
Cable or connector axial/radial	Cable radial	Cable axial
Ø 58 mm, square flange = 63.5 mm / 80 mm	Ø 58 mm, square flange = 63.5 mm	Ø 70 mm
300 g approx.	620 g approx.	1,400 g approx.
RS 422/push-pull/push-pull complementary 5 VDC/10...30 VDC	RS 422/push-pull/push-pull complementary 5 VDC/10...30 VDC	RS 422/push-pull/push-pull complementary 5 VDC/10...30 VDC
40 mA (5 VDC), 30 mA (24 VDC), 60 mA (10 VDC)	40 mA (5 VDC), 30 mA (24 VDC), 60 mA (10 VDC)	40 mA (5 VDC), 30 mA (24 VDC), 60 mA (10 VDC)
300 kHz (RS 422) 200 kHz (push-pull)	300 kHz (RS 422) 200 kHz (push-pull)	300 kHz (RS 422) 200 kHz (push-pull)
RS 422: ± 30 mA push-pull with short circuit protection: 30 mA (10...30 VDC)	RS 422: ± 30 mA push-pull with short circuit protection: 30 mA (10...30 VDC)	RS 422: ± 30 mA push-pull with short circuit protection: 30 mA (10...30 VDC)
NPN-O.C. 5 mA	NPN-O.C. 5 mA	NPN-O.C. 5 mA
1 : 1	1 : 1	1 : 1
± max. 25° electrical	± max. 25° electrical	± max. 25° electrical
68	76	79

Incremental Encoders – with hollow shaft



Type	RI 36-H	RI 58-H
Special features	<ul style="list-style-type: none"> ■ miniature industry encoder for high numbers of pulses ■ short mounting depth ■ easy mounting procedure ■ applications, e.g. motors, machine tools, packaging machines, robots, automated SMD equipment 	<ul style="list-style-type: none"> ■ through hollow shaft ■ high accuracy due to integrated coupling ■ secure shaft mounting ■ applications e.g. textile machinery, motors, drives, copiers
Number of pulses	5 ... 3,600	1 ... 5,000
Technical Data – mechanical Flange or shaft fixation		S = synchro flange
Shaft diameter	hollow shaft 4 mm/6 mm/8 mm/10 mm	Hollow shaft 10 mm/12 mm
Absolute max. shaft load radial/axial	misalignment radial ± 0.15 mm, misalignment axial ± 0.5 mm	misalignment axial ± 0.4 mm misalignment parallel 0.4 mm misalignment angular 1°
Absolute max. speed	10,000 RPM	3,000 RPM
Torque	≤ 0.3 Ncm	≤ 2 Ncm
Protection class Housing/Bearing	IP 64/64	IP 64/64
General design	as per DIN VDE 0160, protection class III	as per DIN VDE 0160, protection class III
Operating temperature	-10...+70 °C	-10...+70 °C
Connection	1.5 m cable* axial/radial	cable radial
Size	$\varnothing 36$ mm	$\varnothing 58$ mm
Weight	ca. 80 g	210 g approx.
Technical data – electrical		
Output	RS 422/push-pull/push-pull complementary	RS 422/push-pull/push-pull complementary
Supply voltage (SELV)	5 VDC/10...30 VDC	5 VDC/10...30 VDC
Max. intrinsic power consumption	40 mA (5 VDC), 30 mA (24 VDC), 60 mA (10 VDC)	40 mA (5 VDC), 30 mA (24 VDC), 60 mA (10 VDC)
Max. pulse frequency	300 kHz (RS 422) 200 kHz (push-pull))	300 kHz (RS 422) 200 kHz (push-pull))
Output load	RS 422: ± 30 mA push-pull with short circuit protection: 30 mA (10...30 VDC)	RS 422: ± 30 mA push-pull with short circuit protection: 30 mA (10...30 VDC)
Alarm output	NPN-O.C. 5 mA	NPN-O.C. 5 mA
Pulse shape		
Pulse duty factor	1 : 1	1 : 1
Pulse width error	\pm max. 25° electrical	\pm max. 25° electrical
Page	82	84



Incremental Encoders – with hollow shaft



Type	RI 58-D	RI 76 TD
Special features	<ul style="list-style-type: none"> ■ direct mounting without coupling ■ flexible hollow shaft concept up to 14 mm ■ through hollow shaft or as end shaft (blind shaft) ■ simple installation with clamping ring or fixing screws ■ short mounting depth of only 33 mm ■ operating temperature up to 100 °C (RI 58 TD) ■ applications, e.g. positioning drives, length measuring machines, motors 	<ul style="list-style-type: none"> ■ through hollow shaft ■ shaft diameters 15 to 42 mm ■ external diameter only 76 mm ■ simple installation with clamping ring front or rear ■ operating temperature up to 100 °C ■ applications e.g. motors, printing machines, elevators
Number of pulses	1 ... 5,000	1...10,000
Technical Data – mechanical		
Flange or shaft fixation	E= synchro flange with blind shaft F, D, H = Synchro flange with clamping shaft	D = clamping ring front (flange side) H = clamping ring rear (cover side)
Shaft diameter	Hollow shaft 10 mm/12 mm/14 mm	Hollow shaft 15...42 mm
Absolute max. speed	6,000 RPM	6,000 RPM (depends on version)
Torque	≤ 1.7 Ncm	3...10 Ncm (depends on version)
Protection class Housing/Bearing	IP 65/64	IP 50/40, Option: IP 65/64
General design	as per DIN VDE 0160, protection class III	as per DIN EN 61010, protection class III
Operating temperature	-10...+70 °C (Option: -25...+100 °C)	-25...+100 °C
Connection	Cable or connector radial	Cable radial
Size	Ø 58 mm	Ø 76 mm
Weight	170 g approx.	320...580 g approx. (depends on version)
Technical data – electrical		
Output	RS 422/push-pull/push-pull complementary	RS 422/push-pull/push-pull complementary
Supply voltage (SELV)	5 VDC/10...30 VDC	5 VDC/10...30 VDC
Max. intrinsic power consumption	40 mA (5 VDC), 30 mA (24 VDC), 60 mA (10 VDC)	40 mA (5 VDC), 30 mA (24 VDC), 60 mA (10 VDC)
Max. pulse frequency	300 kHz (RS 422) 200 kHz (push-pull)	300 kHz (RS 422) 200 kHz (push-pull)
Output load	RS 422: ± 30 mA push-pull with short circuit protection: 30 mA (10...30 VDC)	RS 422: ± 30 mA push-pull with short circuit protection: 30 mA (10...30 VDC)
Alarm output	NPN-O.C. 5 mA	NPN-O.C. 5 mA
Pulse shape		
Pulse duty factor	1 : 1	1 : 1
Pulse width error	± max. 25° electrical	± max. 25° electrical
Page	87	93

Incremental Encoders – Economy Types



Type	RI 32	RI 38
Special features	<ul style="list-style-type: none"> ■ economy encoder for small devices ■ long life due to ball bearings ■ low torque ■ application e.g. laboratory devices, fitness machines, crimping machines, tampon printing machines, small grinding machines 	<ul style="list-style-type: none"> ■ encoder for universal mounting due to front or rear fixing ■ long life due to ball bearings ■ low torque ■ applications e.g. small motors, laboratory devices, labelling devices, plotters, length measuring machines
Number of pulses	5 ... 1,500	5 ... 1,024
Technical Data – mechanical		
Flange or shaft fixation	R = round flange	Q = square flange
Shaft diameter	5 mm/6 mm	6 mm
Absolute max. shaft load radial/axial	30 N/15 N (6.5/3.3 lbs)	30 N/15 N (6.5/3.3 lbs)
Absolute max. speed	6,000 RPM	10,000 RPM
Torque	≤ 0.05 Ncm	≤ 0.2 Ncm
Protection class Housing/Bearing	IP 50/40	IP 50/40
General design	as per DIN VDE 0160, protection class III	as per DIN VDE 0160, protection class III
Operating temperature	-10°...+60 °C	-10°...+60 °C
Connection	cable, radial/axial	cable radial
Size	∅ 30 mm	39 x 39 mm
Weight	50 g approx.	60 g approx.
Technical data – electrical		
Output	push-pull	push-pull
Supply voltage (SELV)	5 VDC or 10...30 VDC	5 VDC or 10...30 VDC
Max. intrinsic power consumption	40 mA (5 VDC), 30 mA (24 VDC)	40 mA (5 VDC), 30 mA (24 VDC),
Max. pulse frequency	300 kHz (5 VDC) 200 kHz (10 ... 30 VDC)	300 kHz (5 V) 200 kHz (10 ... 30 V)
Output load	push-pull with short circuit protection: 10 mA (5 VDC), 30 mA (10...30 VDC)	push-pull with short circuit protection: 10 mA (5 VDC), 30 mA (10...30 VDC)
Alarm output	NPN-O.C. 5 mA	NPN-O.C. 5 mA
Pulse shape		
Pulse duty factor	1 : 1	1 : 1
Pulse width error	± max. 25° electrical	± max. 25° electrical
Page	96	98

Incremental Encoders – Economy Types



Type	RI 41	RI 42
Special features	<ul style="list-style-type: none"> ■ economy encoder ■ high mechanical life ■ applications e.g. small motors, graphic machines, desktop robots, wood working machines 	<ul style="list-style-type: none"> ■ economy encoder ■ high protection IP 65 ■ push-pull or NPN-O.C. ■ applications, e.g. textile machinery
Number of pulses	5 ... 3,600	5 ... 1,024
Technical Data – mechanical		
Flange or shaft fixation	R = round flange	R = round flange
Shaft diameter	6 mm	6 mm
Absolute max. shaft load radial/axial	30 N/15 N (6.5/3.3 lbs)	30 N/15 N (6.5/3.3 lbs)
Absolute max. speed	10,000 RPM	10,000 RPM
Torque	≤ 0.2 Ncm	≤ 1 Ncm
Protection class Housing/Bearing	IP 50/40	IP 65/64
General design	as per DIN VDE 0160, protection class III	as per DIN VDE 0160, protection class III
Operating temperature	-10°...+70 °C	0°...+60 °C
Connection	cable radial	cable axial
Size	Ø 40 mm	Ø 40 mm
Weight	60 g approx.	approx. 75 g
Technical data – electrical		
Output	push-pull	push-pull/push-pull complementary/ NPN-O.C
Supply voltage (SELV)	5 VDC or 10...30 VDC	5 VDC/10...30 VDC/10...24 VDC
Max. intrinsic power consumption	40 mA (5 VDC), 30 mA (24 VDC),	40 mA (5 VDC), 30 mA (24 VDC),
Max. pulse frequency	300 kHz (5 VDC) 200 kHz (10 ... 30 VDC)	300 kHz (5 V) 200 kHz (10 ... 30 V) 50 kHz (10...24 VDC)
Output load	push-pull with short circuit protection: 10 mA (5 VDC), 30 mA (10...30 VDC)	NPN-O.C.:30 mA (10...24 VDC) push-pull with short circuit protection 10 mA (5 VDC), 30 mA (10...30 VDC)
Alarm output	NPN-O.C. 5 mA	NPN-O.C. 5 mA
Pulse shape		
Pulse duty factor	1 : 1	1 : 1
Pulse width error	± max. 25° electrical	± max. 25° electrical
Page	100	102

Measuring Signals

SINGLE-CHANNEL SHAFT ENCODERS

Single-channel shaft encoders have only one output channel (A). They are used wherever it is not necessary to detect the direction of

rotation, such as in adding or subtracting counters or tachometers.

TWO-CHANNEL SHAFT ENCODERS

These shaft encoders use two scanning systems, and output the signal pulses generated on two output channels (A and B). The output pulses from the two channels are 90° out of phase. A downstream logic circuit can derive the encoder's direction of rotation

from this phase shift. Two-channel shaft encoders are used wherever it is necessary to detect the direction of rotation, such as in up/down counters or positioning devices.

THREE-CHANNEL SHAFT ENCODERS

In principle, these are two-channel shaft encoders which supply one pulse per revolution of the encoder on a third channel (N). This pulse is needed for precise determination of a reference position, for example. It is

called the zero signal or reference signal. Shaft encoders with a zero signal are used very often in positioning systems.

HENGSTLER SHAFT ENCODERS

All incremental HENGSTLER shaft encoders of the new generation with OPTOASIC are three-channel shaft encoders.

When applied as single- or two-channel shaft encoders the dispensable output signals can be omitted.

OUTPUT SIGNALS

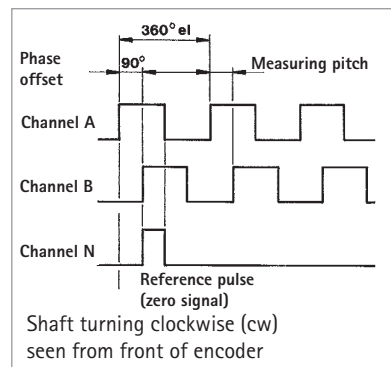

The shaft encoders supply two squarewave pulses offset by 90° A and B, and a reference pulse N (zero signal) as well.

In order to suppress spurious pulses, certain output circuits (RS 422 and push-pull) generate inverted signals (\bar{A} , \bar{B} , \bar{N}), such as in models RI 30, RI 36, RI 58, RI 58-H, RI 76-TD and RI 58-D.

The measuring pitch is defined as the value of the distance between two pulse edges of A and B.

EVALUATION

The resolution of a two-channel shaft encoder can be doubled or quadrupled in the subsequent circuitry. This enables the resolution of a two-channel encoder with

2,500 lines per rev. to be increased electronically to 5,000 or 10,000 pulses per revolution (see diagram below).

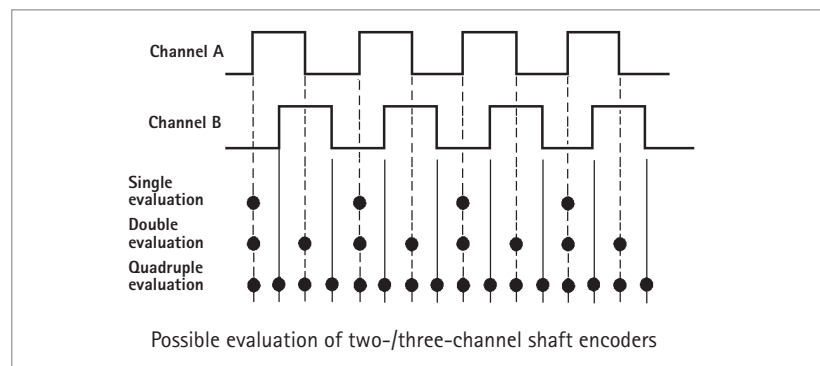

Maximum Speed, Protection Class

SPEED

The maximum permissible speed of a shaft encoder is derived from:

- the **mechanically permissible** r.p.m,
- the minimum permissible **pulse-edge** spacing of the square-wave output signals of the shaft encoder for the subsequent circuitry, which depends on the tolerance of the phase offset,
- the **functional speed**, which is limited by the pulse frequency.

The **mechanically permissible r.p.m.** is specified for each shaft encoder among the mechanical characteristics.

In general, the control circuitry does not permit less than a certain **minimum edge spacing** between the square-wave output signal pulses. The minimum pulse-edge spacing is specified for each model of shaft encoder among the electrical characteristics.

The **functional speed** of an encoder is obtained by the equation:

$$n_{\max} = f_{\max} \cdot 10^3 \cdot 60 / Z$$

n_{\max} = maximum functional speed [r.p.m.]

f_{\max} = maximum pulse frequency of shaft encoder, or input frequency of downstream circuitry [kHz]

Z = number of pulses of shaft encoder

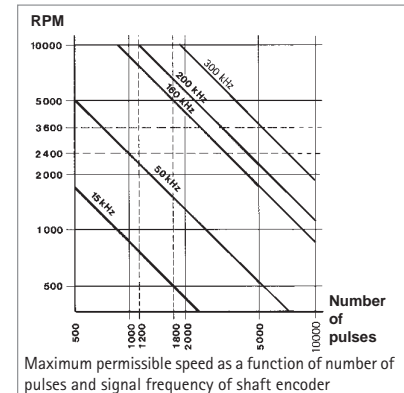

PROTECTION CLASS

All encoders of the industrial types RI 30, RI 36, RI 58, RI 58-H, RI 58-D, RX 70-I as well as the absolute encoders RA 58, comply with protection class IP 65 according to EN 60529 and IEC 529, unless otherwise stated.

These specifications are valid for the housing and the cable output and also for plugged in socket connectors.

The shaft input complies with protection class IP 64. If however the encoder is mounted vertically, there must be no standing water present at the shaft input and the ball bearings.

In case the standard protection class IP 64 is not sufficient for the shaft input, e.g. with vertical mounting of the encoder, the encoders must be protected by additional labyrinth or pot-type seals. On request our encoders are also available with protection class IP 67 for the shaft input and for the housing.

Examples of Flange Mounting

FLANGE TYPE OVERVIEW

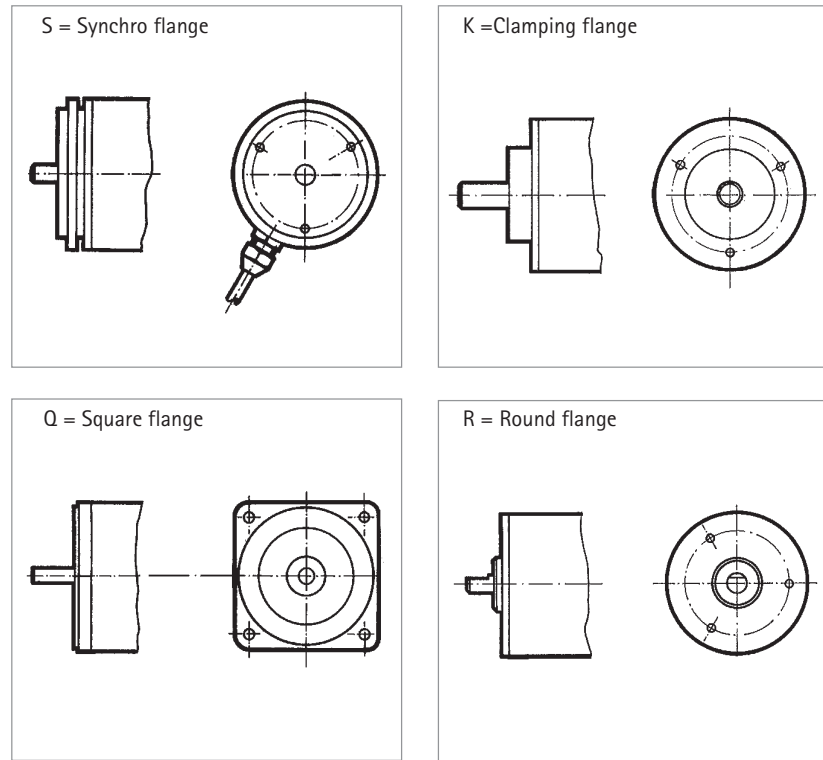

SHAFT ENCODERS WITH CLAMPING FLANGE

The shaft encoders with a clamping flange can be installed in following ways:

- by means of various flange adapters (see "Accessories"),
- by means of the clamping flange itself,
- by means of the fastening threads provided on the face,
- by means of an angle bracket (see Accessories").

The encoder housing is centered by means of the clamping flange.

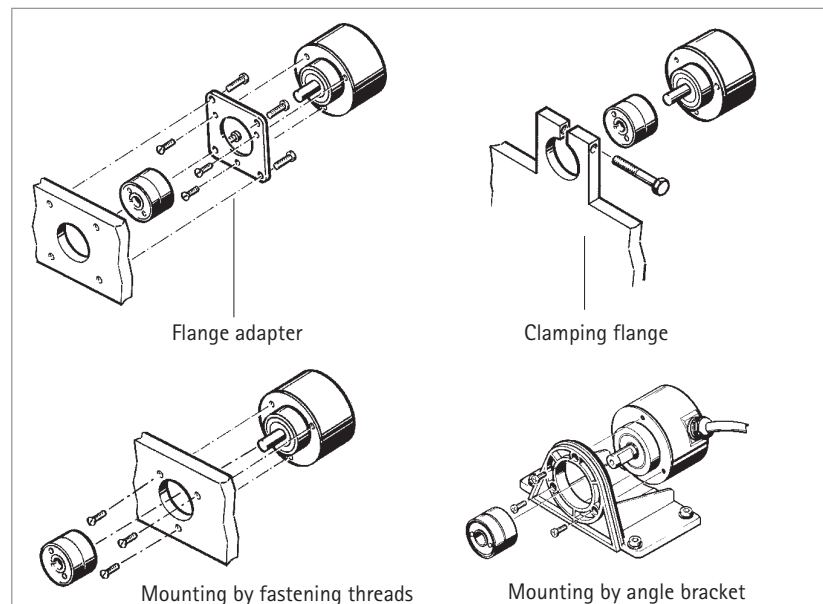

Examples of Flange Mounting

SHAFT ENCODERS WITH SYNCHRO FLANGE

The shaft encoders with synchro flange can be installed in two ways:

- by means of the synchro flange and three clamping eccentrics (see "Accessories"),
- by means of the fastening threads provided on the face.

The encoder is centered by means of the centering collar on the flange.

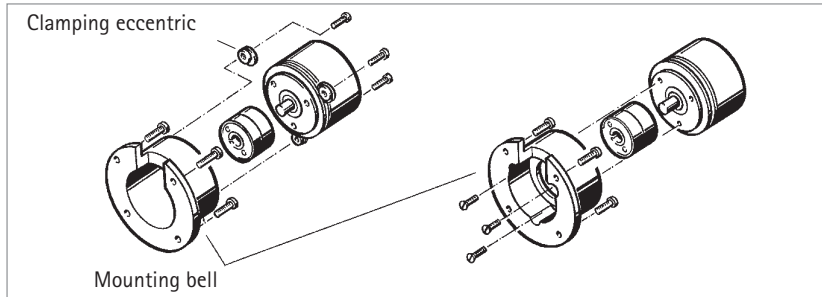

SHAFT ENCODERS WITH SQUARE FLANGE

The shaft encoders with square flange can be installed in two ways:

- by means of the fastening threads provided on the face,
- by means of an angle bracket.

The encoder is centered by means of the centering collar on the flange.

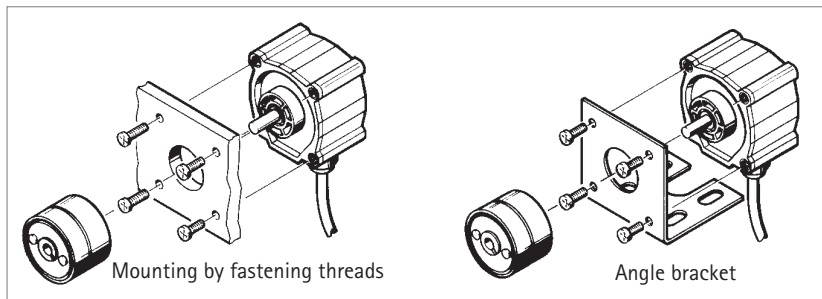

SHAFT ENCODERS WITH ROUND FLANGE

The shaft encoders with round flange can be installed in two ways:

- by means of the fastening threads provided on the face,
- by means of an angle bracket.

The encoder is centered by means of the centering collar on the flange.

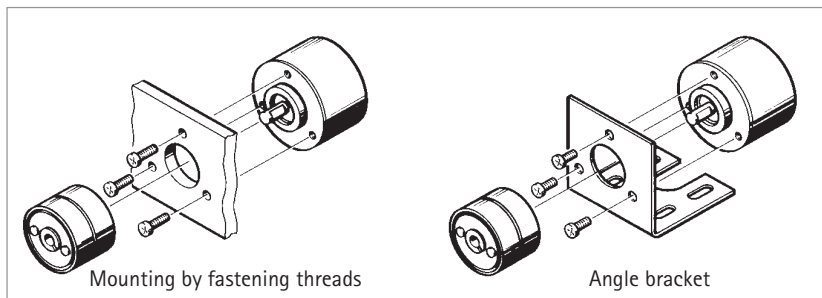

Examples of Flange Mounting

SHAFT ENCODERS WITH HOLLOW SHAFT (RI 58-H)

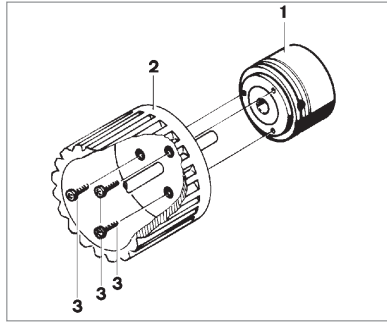

- a) Mounting by screws
 1 Hollow-shaft encoder
 2 "B"-side of drive shaft
 3 Fastening screws (M4)

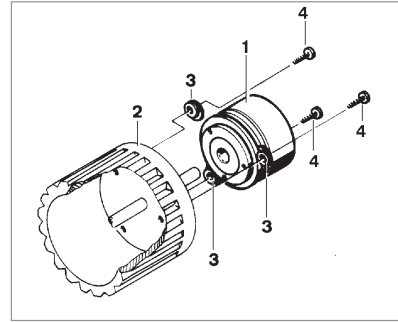

- b) Mounting by clamping eccentrics
 1 Hollow-shaft encoder
 2 "B"-side of drive shaft
 3 Clamping eccentrics
 4 Fastening screws

SHAFT ENCODERS WITH HOLLOW SHAFT (RI 58-D/G)

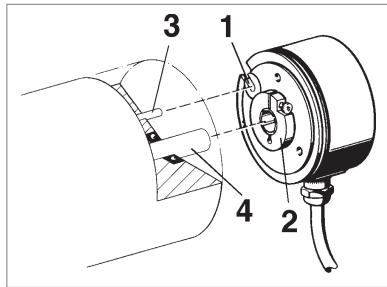

Mounting of version F, D (Clamping shaft)

- 1 Torque spring
 2 Clamping ring with cross-recess screw
 3 Straight pin
 4 Actuating shaft

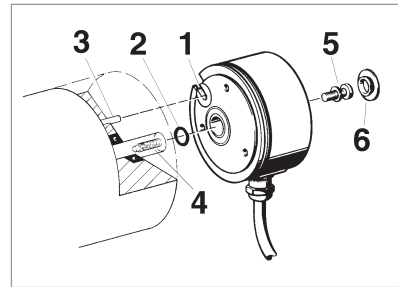

Mounting of version E (Blind shaft)

- 1 Torque spring
 2 O-ring
 3 Straight pin
 4 Actuating shaft with threaded bore
 5 M4-screw with spring washer
 6 Cap

SHAFT ENCODERS WITH SOLID SHAFT

Connection of solid-shaft encoders to the shaft is by means of a coupling. The coupling compensates for axial movements and lack of alignment between the shaft encoder and the drive shaft, thus preventing excessive bearing loads on the encoder shaft. For further details please refer to heading "Accessories".

Output RS 422

OUTPUT CIRCUIT

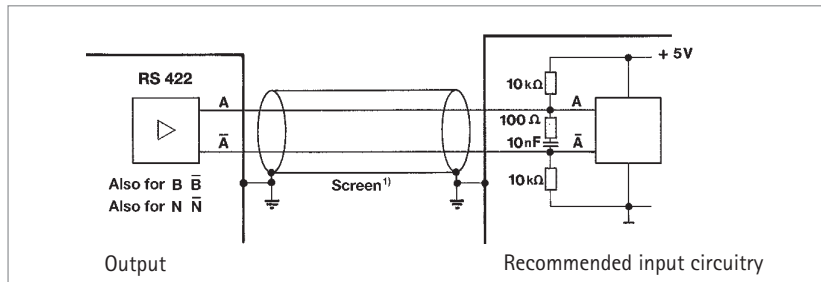

- ¹⁾ Cable screen:
- not existing for RI 32, 38, 42
 - connected to encoders housing for RI 30, 36, 58, 59, 76 and RX 70

TECHNICAL DATA

Code Letter	R = RS 422 + Alarm ³⁾ (with $U_B = 5/10...30$ VDC) T = RS 422 + Sense ⁴⁾ (only with $U_B = 5$ VDC)
Output signals shaft turning clockwise (cw) seen from front of encoder	<p>Square wave pulses (TTL) for channels A, B, N and their inverted signals \bar{A}, \bar{B}, \bar{N}</p>
Delay times at 1.5 m cable	<p>≤ 100 ns ≤ 100 ns</p>
Pulse shape	
Pulse duty factor	1:1
Pulse width error ¹⁾	$\pm 25^\circ$ electrical
Max. pulse frequency	300 kHz
Output voltage	0... + 5 VDC ²⁾
Output level	$H \geq 2.5$ VDC/ $L \leq 0.5$ VDC (TTL-level)
Output load max.	± 30 mA
Short circuit protection	with $U_B = 5$ VDC: only 1 channel at a time for max. 1 s (standard RS 422-driver) with $U_B = 10...30$ VDC: short circuit proof for all channels due to integrated controller
Pole protection of U_B	with $U_B = 5$ VDC: no with $U_B = 10...30$ VDC: yes

- ¹⁾ distance from A to B is at least $0.45 \mu\text{s}$ (at 300 kHz) ³⁾ Description - see Outputs-Alarm
²⁾ also for $U_B = 10...30$ VDC ⁴⁾ Description - see Outputs-Sense

CABLE LENGTH

depending on voltage and frequency (at 25°C) ¹⁾ :	
length	RS 422
10 m	5 VDC, 300 kHz
50 m	5 VDC, 300 kHz
100 m	5 VDC, 300 kHz

- ¹⁾ with respect to Hengstler own cables

OUTPUT CIRCUIT

TECHNICAL DATA

CABLE LENGTH

Output

Push-pull

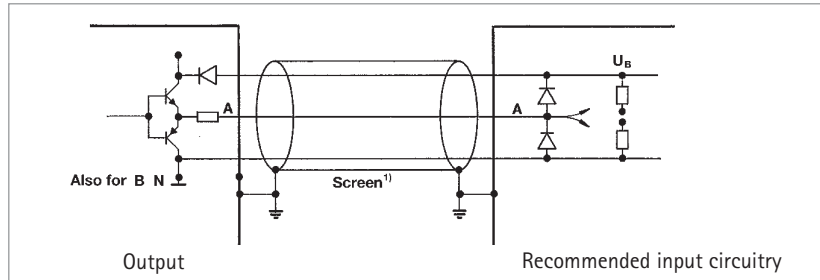

¹⁾ Cable screen:

- not existing for RI 32, 38, 42
- RI 41, not connected to encoder housing
- connected to encoders housing for RI 30, 36, 58, 59, 76 and RX 70

Code Letter	K = push-pull, 10 mA with $U_B = 5$ VDC or push-pull, 30 mA with $U_B = 10...30$ VDC D = push-pull, 30 mA with $U_B = 5$ VDC		
Output signals shaft turning clockwise (cw) seen from front of encoder			
Delay times with 1.5 m Cable			
Pulse shape			
Pulse duty factor	1:1		
Pulse width error ¹⁾	$\pm 25^\circ$ electrical		
Max. pulse frequency	300 kHz (see cable length)		
Output voltage	$0... + U_B$		
Output level	K	K	D
	push-pull (10...30 V)	push-pull (5 V)	push-pull (5 V)
	$H \geq U_B - 3V$	$H \geq 2,5 V$	$H \geq 2,5 V$
	$L \leq 2 V$	$L \leq 0,5 V$	$L \leq 0,5 V$
Output load max.	± 30 mA	± 10 mA	± 30 mA
Short circuit protection	all channels	all channels	1 channel ²⁾
Pole protection of U_B	with $U_B = 5$ VDC: output K yes, output D no with $U_B = 10...30$ VDC: yes		

¹⁾ Distance A to B min. $0.45 \mu s$ (at 300 kHz)

²⁾ only 1 channel at a time for max. 1 s

depending on voltage and frequency (at 25°C) ¹⁾ :			
length	push-pull (K)	push-pull (D)	push-pull (K)
	5 VDC, 10 mA	5 VDC, 30 mA	10...30 VDC, 30 mA
10 m	300 kHz	300 kHz	12 VDC, 200 kHz 24 VDC, 200 kHz 30 VDC, 200 kHz
50 m		300 kHz	12 VDC, 200 kHz 24 VDC, 200 kHz 30 VDC, 100 kHz
100 m		300 kHz	12 VDC, 200 kHz 24 VDC, 100 kHz 30 VDC, 50 kHz

¹⁾ with respect to Hengstler own cables

Output

Push-pull complementary

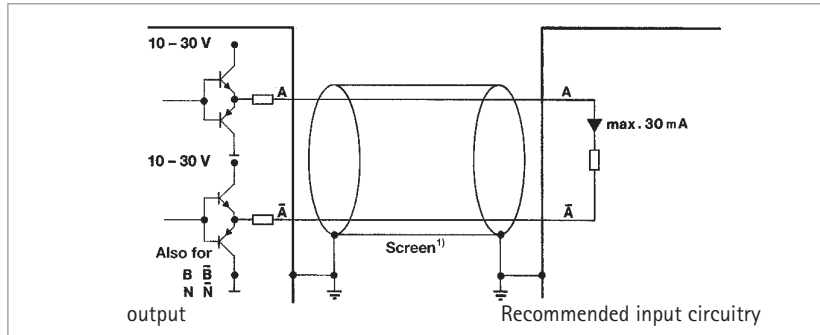

¹) Cable screen connected with encoder housing

TECHNICAL DATA

Code Letter	I = push-pull complementary (with $U_B = 10...30\text{ V}$)
Output signals shaft turning clockwise (cw) seen from front of encoder	<p>Square wave pulses (HTL) for channels A, B, N and their inverted signals \bar{A}, \bar{B}, \bar{N}</p>
Delay times at 1.5 m cable	<p>$\leq 250\text{ ns} \leq 250\text{ ns}$</p>
Pulse shape	
Pulse duty factor	1:1
Pulse width error ¹)	$\pm 25^\circ$ electrical
Max. pulse frequency	200 kHz (see cable length)
Output voltage	$0... + U_B$
Output level	$H \geq U_B - 3\text{ V/L} \leq 2\text{ V}$
Output load max.	$\pm 30\text{ mA}$
Short circuit protection	short circuit proof for all channels due to integrated controller
Pole protection of U_B :	yes

¹) distance from A to B is at least $0.7\ \mu\text{s}$ (at 200 kHz)

CABLE LENGTH

depending on voltage and frequency (at 25°C) ¹):	
length	push-pull complementary
10 m	12 VDC, 200 kHz
	24 VDC, 200 kHz
	30 VDC, 200 kHz
50 m	12 VDC, 200 kHz
	24 VDC, 50 kHz
	30 VDC, 25 kHz
100 m	12 VDC, 150 kHz
	24 VDC, 25 kHz
	30 VDC, 12 kHz

¹) with respect to Hengstler own cables

Output

Alarm

OUTPUT CIRCUIT

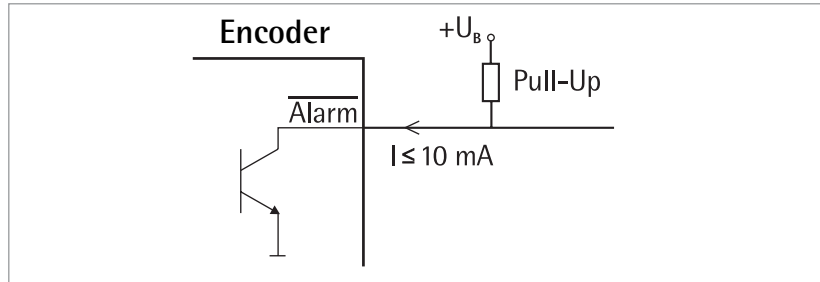

TECHNICAL DATA

Output	NPN - open collector
Output load max.	5 mA/24 V at $U_B = 5$ VDC 5mA/32 V at $U_B = 10...30$ VDC
Output Level	Output active (failure condition): $L \leq 0.7$ VDC Output inactive: highohmic (if necessary: get H-level by an external pull-up resistor)
Malfunction indication time	≥ 20 ms

FUNCTION

The rotary encoders are equipped with an electronic monitoring system which reports malfunctions via a separate alarm output.

The alarm output can be used for selecting an optical display (LED; for circuit, see above) or the control system (SPC or similar).

Moreover, the alarm outputs of several encoders can be interconnected to a common "systems alarm" by means of a parallel connection. The following malfunctions are indicated:

Category I	Category II	Category III
- damaged disks	- overtemperature	- voltage range $1 \text{ VDC} < U < 4 \text{ VDC}$
- defective LED	- overload (e. g. due to short circuit)	- voltage drop on the supply lines
- contamination		

Category I malfunctions cannot be corrected; the encoder must be replaced.

Category II malfunctions are detected by means of a thermal monitoring unit in the electronic system. The alarm message is cleared after the cause of temperature increase has been removed.

Category III malfunctions indicate insufficient supply voltage. Also included in this category are transients in the supply voltage, e.g. due to electrostatic discharge, which may distort the output signals.

This is corrected by

- readjustment to the correct voltage
- eliminating the cause of disturbance, i.e. by careful arrangement of the cables.

Output

Sense at RS 422 (T)

OUTPUT CIRCUIT

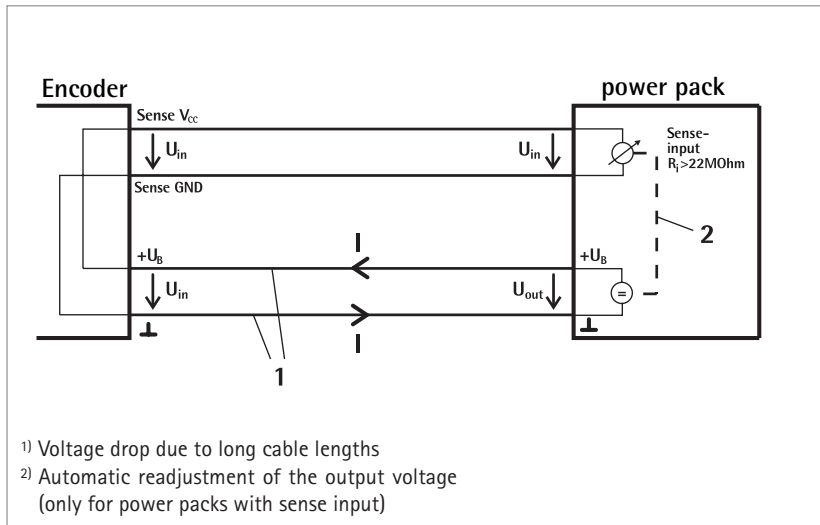

FUNCTION

The sense cables enable the measuring of the actual sensor voltage (no corruption due to voltage drop resulting from supply current and cable resistance).

Due to the voltage drop in the cables and the voltage supply, the encoder input voltage U_{in} is less than the power pack output voltage U_{out} .

The present input voltage U_{in} is now output to the Sense V_{cc} and Sense GND cables and returns as data to the power pack.

The input resistance R_i on the power pack should amount to at least 22 M Ohm so that no voltage drop occurs on these cables.

In case of power packs with sense input, it is now possible to readjust the output voltage U_{out} automatically.

Code Table for Incremental Shaft Encoders

<p>Type RI 30, 32, 36, 38, 41, 42, 58, 59, RX 70, RI 76 4)</p> <p>Version D direct hollow shaft H hollow shaft with integrated coupling O standard T high temperature I incremental (only for RX 70)</p> <p>Number of pulses</p> <p>Supply voltage A 5 VDC E 10 ...30 VDC</p> <p>Type of flange A synchro flange adapter C square flange adapter; 58 x 58 mm D synchro flange with continuous shaft, front clamping ring E synchro flange with blind shaft F synchro flange with clamping shaft G square flange adapter; 80 x 80 mm H synchro flange with continuous shaft, rear clamping ring K clamping flange (M3 fastening thread) L clamping flange (M4 fastening thread) M synchro clamping flange; Ø 63.5 mm Q square flange; 63.5 x 63.5 mm R round flange S synchro flange X special version</p>	<div style="text-align: center; margin-bottom: 10px;"> </div> <p>Connector²⁾ (unnecessary for standard: cable with tinned lead) A Souriau coupling, socket B VDW connector, right-turning, pins C CONIN connector, right-turning, pins D CONIN coupling, left-turning, pins E VDW coupling, left-turning, pins S special version</p> <p>Cable length³⁾ (unnecessary for standard: 1.5 m) D Ø = 3 m F Ø = 5 m K Ø = 10 m</p> <p>Connection A PVC cable, axial B PVC cable, radial C CONIN¹⁾ 12 pole, axial, clockwise D CONIN¹⁾ 12 pole, radial, clockwise E TPE cable, axial F TPE cable, radial G CONIN¹⁾ 12 pole, axial, counter clockwise H CONIN¹⁾ 12 pole, radial, counter clockwise J BINDER¹⁾ – 6 pole radial K MIL¹⁾ – 10 pole radial L MIL¹⁾ 7 pole, radial M MIL¹⁾ 6 pole, axial N BINDER¹⁾ 6 pole, axial O MIL¹⁾ 10 pole, axial P MIL¹⁾ 7 pole, axial Q MIL¹⁾ 6 pole, radial R MIL¹⁾ 10 pole, US axial T MIL¹⁾ 10 pole, US radial 1 KPT¹⁾ 12-8P, axial 2 KPT¹⁾ 12-8P, radial X special version</p> <p>Output D push-pull 5 V DC=, 30 mA I push-pull, complementary + Alarm K push-pull, short circuit proof + Alarm R RS 422 + Alarm T RS 422 + Sense X special version</p> <p>Shaft</p> <table style="width: 100%; border: none;"> <tr> <td style="width: 5%;">0</td><td style="width: 20%;">4 mm</td><td style="width: 5%;"></td><td style="width: 5%;">8</td><td style="width: 20%;">6 x 19,5 mm</td></tr> <tr> <td>1</td><td>6 mm</td><td></td><td>9</td><td>14 mm</td></tr> <tr> <td>2</td><td>10 mm</td><td></td><td>A</td><td>10 mm x 25 mm</td></tr> <tr> <td>3</td><td>7 mm</td><td></td><td>B</td><td>9,52 mm x 25 mm</td></tr> <tr> <td>4</td><td>5 mm</td><td></td><td>C</td><td>8 mm</td></tr> <tr> <td>5</td><td>6,35 mm</td><td></td><td>D</td><td>15 mm</td></tr> <tr> <td>6</td><td>9,52 mm</td><td></td><td>X</td><td>special version</td></tr> <tr> <td>7</td><td>12 mm</td><td></td><td></td><td></td></tr> </table> <p>Protection class 1 IP 40 (housing IP 50) 7 IP 67 (housing IP 67) 3 IP 64 (housing IP 64) X special version 4 IP 64 (housing IP 65)</p>	0	4 mm		8	6 x 19,5 mm	1	6 mm		9	14 mm	2	10 mm		A	10 mm x 25 mm	3	7 mm		B	9,52 mm x 25 mm	4	5 mm		C	8 mm	5	6,35 mm		D	15 mm	6	9,52 mm		X	special version	7	12 mm			
0	4 mm		8	6 x 19,5 mm																																					
1	6 mm		9	14 mm																																					
2	10 mm		A	10 mm x 25 mm																																					
3	7 mm		B	9,52 mm x 25 mm																																					
4	5 mm		C	8 mm																																					
5	6,35 mm		D	15 mm																																					
6	9,52 mm		X	special version																																					
7	12 mm																																								

- ¹⁾ CONIN, BINDER, MIL and KPT indicate the connectors with pins on the encoder housing
²⁾ only for connection of TPE cable (E, F)
³⁾ only with connection cable (A, B, E, F) and differing from standard (1.5 m resp. 1.0 m + plug) special lengths for larger quantities on request.
⁴⁾ e.g. RI 76 see section RI 76

Example:	RI 58-H/5000ES.37KB-D0
Type:	RI 58-H
Number of pulses:	5,000
E: Supply voltage:	10...30 VDC=
S: Type of flange:	Synchro flange
3: Protection class:	IP 64
7: Shaft diameter:	12 mm
K: Output circuit:	push-pull short circuit proof + Alarm
B: Type of connection:	PVC cable, radial
D0: Cable length:	3.0 m

Industrial types



- Miniature encoder for industrial use
- Low current consumption
- High noise interference immunity
- Cable lengths of up to 100 m
- Suitable for high pulse frequencies
- High protection class
- Application e.g.:
CNC machines, manipulators, motors,
medical technology, textile machines

NUMBER OF PULSES

5 / 10 / 20 / 25 / 30 / 50 / 60 / 100 / 120 / 128 / 200 / 250 / 256 / 288 / 300 / 360 / 400 / 500 / 512 / 600 / 720 / 900 / 1,000 / 1,024 / 1,250 / 1,500
Other numbers of pulses available on request

TECHNICAL DATA
mechanical

Shaft diameter	5 mm
Absolute max. shaft load	radial 30 N / axial 15 N (6.5/3.3 lbs)
Absolute maximum speed	max. 10,000 RPM
Torque	≤ 0.2 Ncm
Moment of inertia	ca. 0.8 gcm ²
Protection class (EN 60529)	Housing IP 64, bearings IP 64
Operating temperature	-10 ... +70 °C
Storage temperature	-25 ... +85 °C
Vibration performance	100 m/s ² (10 ... 2000 Hz)
Shock resistance	1,000 m/s ² (6 ms)
Type of connection	1.5 m cable radial/axial ¹⁾ , connector axial
Housing	aluminium
Flange	S = synchro flange, R = round flange
Weight	60 g approx.
Bearing life	1 x 10 ¹⁰ revolutions (typ.) at 35% of full rated shaft load 1 x 10 ⁹ revolutions (typ.) at 75% of full rated shaft load 1 x 10 ⁸ revolutions (typ.) at 100% of full rated shaft load For example 30,000 h at 6,000 RPM with a 2 lb radial load

¹⁾ Other cable length on request

TECHNICAL DATA
electrical

General design	as per DIN VDE 0160, protection class III, contamination level 2, overvoltage class II	
Supply voltage (SELV)	with RS 422 (R, T):	5VDC ± 10%
	with push-pull (K):	10 ... 30VDC ¹⁾
Power consumption	40 mA (5VDC), 60 mA (10VDC), 30 mA (24VDC)	
Standard-Output versions ²⁾	RS 422 (R)	A, B, N, \bar{A} , \bar{B} , \bar{N} , \bar{Alarm}
	RS 422 (T)	A, B, N, \bar{A} , \bar{B} , \bar{N} , Sense
	push-pull (K)	A, B, N, \bar{Alarm}

¹⁾ Pole protection

²⁾ Output description and technical data see section „Output“.

Incremental Shaft Encoders Type RI 30

Industrial types

DIMENSIONED DRAWINGS
(Dimensions in mm)

Synchro flange, cable

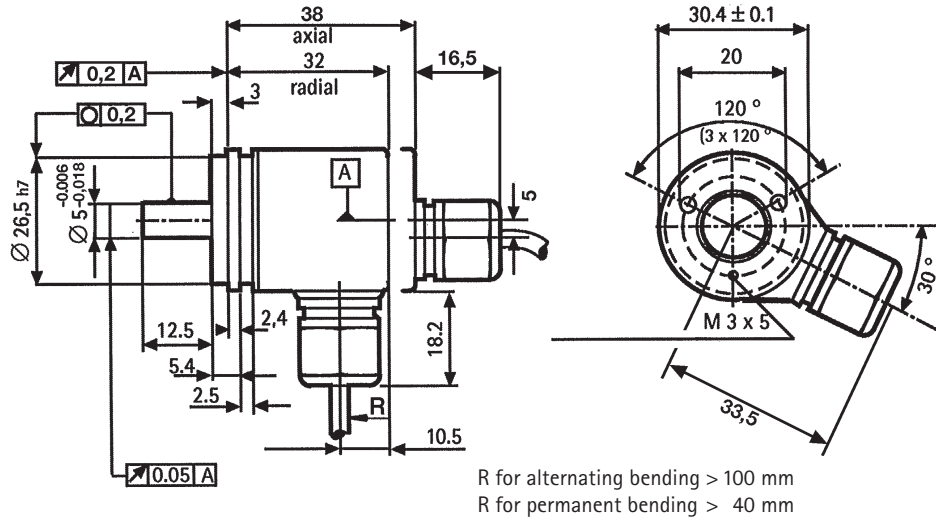

Round flange, cable

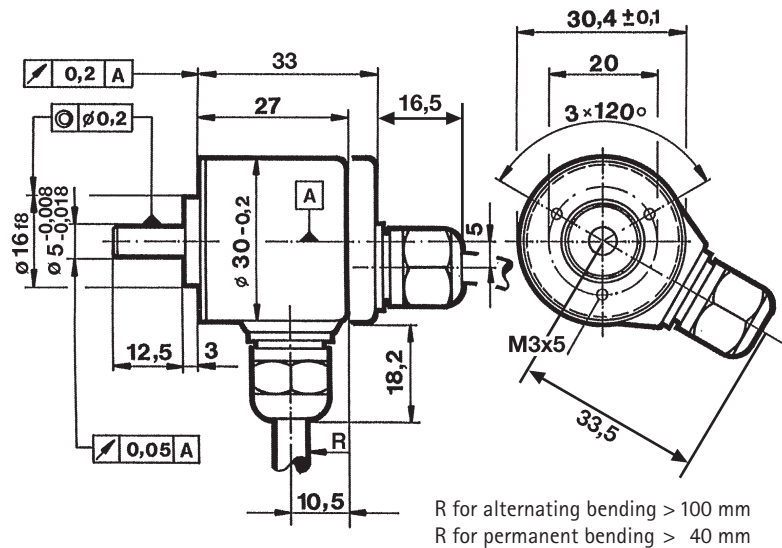

Incremental Shaft Encoders Type RI 30

Industrial types

Synchro flange, BINDER

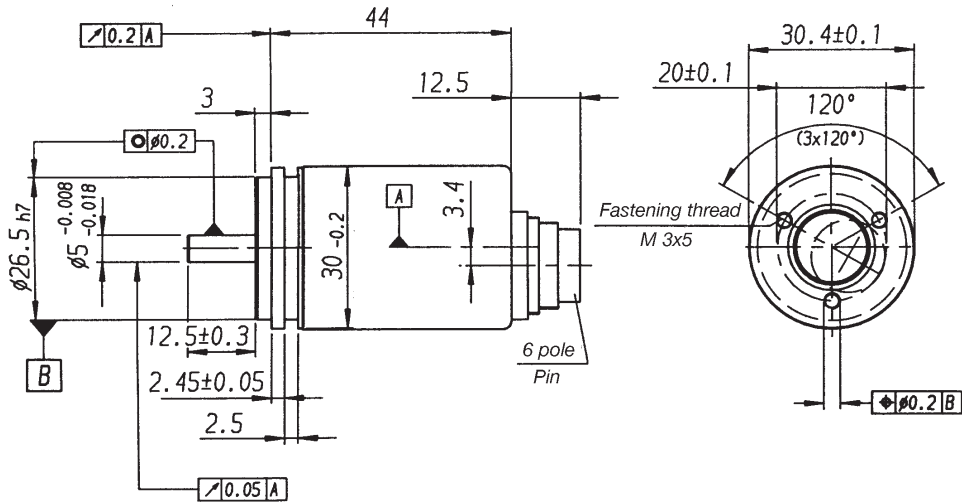

Round flange, BINDER

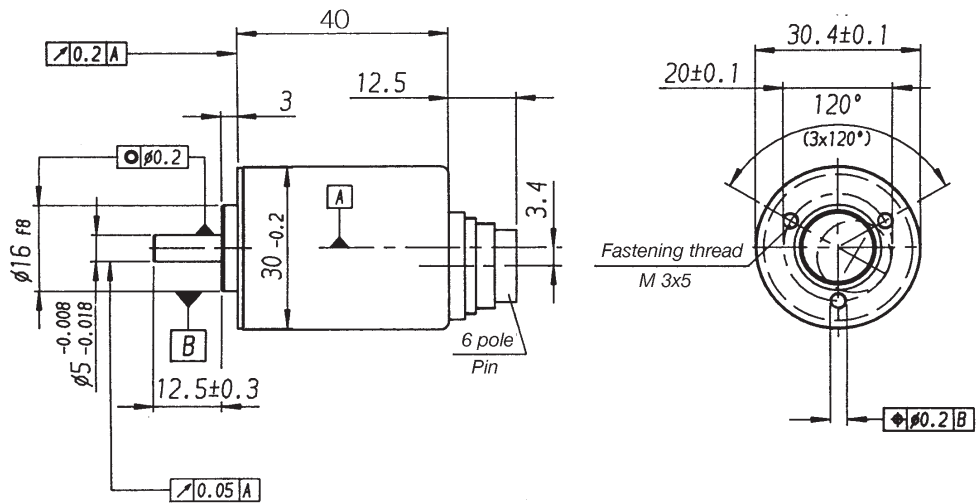

Incremental Shaft Encoders Type RI 30

Industrial types

CONNECTOR 6 POLE (BINDER)

Description (push-pull)	Pin
10 ... 30 VDC	1
Channel A	2
Channel N	3
Channel B	4
Alarm	5
GND	6

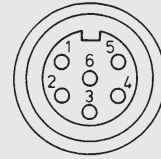

CONNECTION DIAGRAM cable

Description (push-pull)	Description (RS 422)	Lead Ø mm ²	Colour
10 ... 30 VDC	5 VDC	0.5	red
	Sense V _{CC}	0.14	yellow/red
Channel A	Channel A	0.14	white
	Channel A̅	0.14	white/brown
Channel B	Channel B	0.14	green
	Channel B̅	0.14	green/brown
Channel N	Channel N	0.14	yellow
	Channel N̅	0.14	yellow/brown
GND	GND	0.5	black
Alarm	Alarm/Sense GND ¹⁾	0.14	yellow/black
screen ²⁾	screen ²⁾		screen ²⁾

¹⁾ depending on ordering code

²⁾ connected to housing

ORDERING DATA

0 standard	Supply voltage A 5 VDC E 10 ... 30 VDC (only with push-pull)	Type of flange S synchro flange R round flange	Shaft diameter 4 5 mm
-------------------	--	--	--------------------------

R	I	3	0	/				·	3		4		
---	---	---	---	---	--	--	--	---	---	--	---	--	--

Number of pulses 5 ... 1,500	Protection class 3 IP 64	Output T RS 422 + Sense K push-pull short circuit proof R RS 422 + Alarm	Type of connection A cable axial B cable radial N BINDER ¹⁾ 6 pole, axial (only push-pull)
---------------------------------	-----------------------------	---	---

¹⁾ encoder connector with pins

Industrial types



NUMBER OF PULSES

- Miniature industry standard encoder for high numbers of pulses
- High reliability
- Application e.g.:
 - CNC axles
 - Machine tools
 - Robots
 - Special purpose machines
 - High-speed winding machines

5 / 10 / 20 / 25 / 28 / 32 / 50 / 60 / 72 / 100 / 128 / 144 / 200 / 250 / 256 / 288 / 300 / 360 / 400 / 500 / 512 / 600 / 720 / 900 / 1,000 / 1,024 / 1,250 / 1,500 / 2,000 / 2,048 / 2,500 / 3,000 / 3,600

Other numbers of pulses available on request

TECHNICAL DATA
mechanical

Shaft diameter	6 mm / 6,35 mm
Absolute max. shaft load	radial 30 N / axial 15 N (6.5/3.3 lbs)
Absolute maximum speed	max. 10,000 RPM
Torque	≤ 0.3 Ncm
Moment of inertia	ca. 2.8 gcm ²
Protection class (EN 60529)	Housing IP 64, bearings IP 64
Operating temperature	-10 ... +70 °C
Storage temperature	-25 ... +85 °C
Vibration performance	100 m/s ² (10 ... 2,000 Hz)
Shock resistance	1,000 m/s ² (6 ms)
Type of connection	1.5 m cable or connector, axial or radial ¹⁾
Housing	aluminium
Flange	S = synchro flange, R = round flange
Wight	80 g approx.
Bearing life	1 x 10 ¹⁰ revolutions (typ.) at 35% of full rated shaft load 1 x 10 ⁹ revolutions (typ.) at 75% of full rated shaft load 1 x 10 ⁸ revolutions (typ.) at 100% of full rated shaft load For example 30,000 h at 6,000 RPM with a 2 lb radial load

¹⁾ Other cable length on request

TECHNICAL DATA
electrical

General design	as per DIN VDE 0160, protection class III, contamination level 2, overvoltage class II	
Supply voltage (SELV)	with RS 422 (R, T):	5 VDC ± 10%
	with push-pull (K, I):	10 ... 30VDC ¹⁾
Power consumption	40 mA (5 VDC), 60 mA (10 VDC), 30 mA (24 VDC)	
Standard-Output versions ²⁾	RS 422 (R):	A, B, N, \bar{A} , \bar{B} , \bar{N} , Alarm
	RS 422 (T):	A, B, N, \bar{A} , \bar{B} , \bar{N} , Sense
	push-pull (K):	A, B, N, Alarm
	push-pull complementary (I):	A, B, N, \bar{A} , \bar{B} , \bar{N} , Alarm

¹⁾ Pole protection

²⁾ Output description and technical data see section „output“.

Incremental Shaft Encoders Industrial types

Type RI 36

DIMENSIONED DRAWINGS

Synchro flange

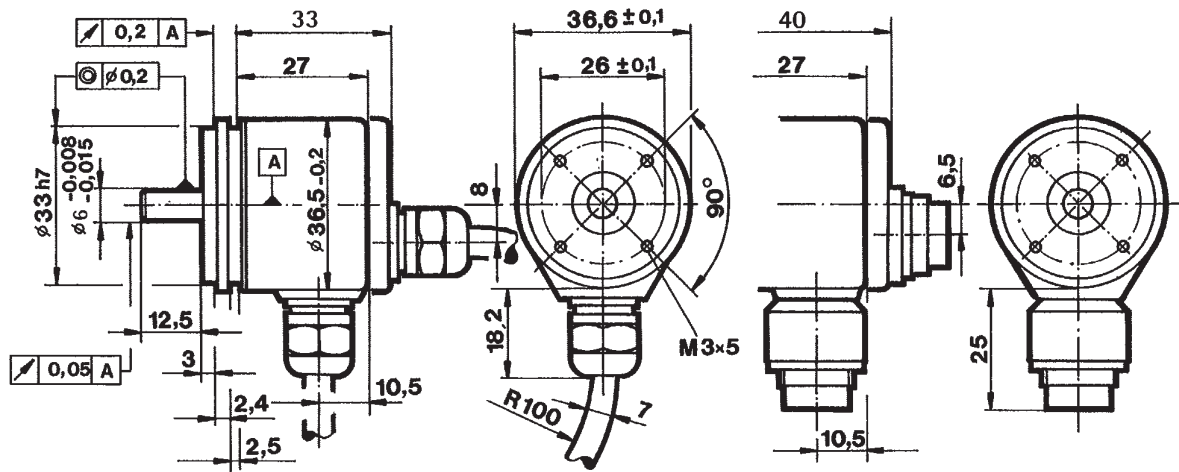

R for alternating bending > 100 mm
R for permanent bending > 40 mm

Round flange

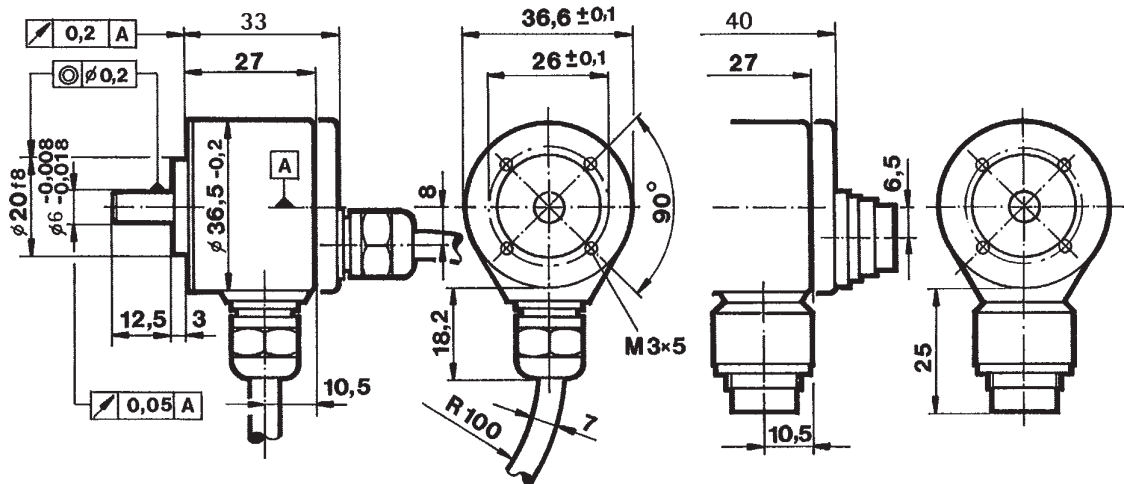

Dimensions in mm

R for alternating bending > 100 mm
R for permanent bending > 40 mm

CONNECTOR 6 POLE (BINDER)

Description (push-pull)	Pin
10 ... 30 VDC	1
Channel A	2
Channel N	3
Channel B	4
Alarm	5
GND	6

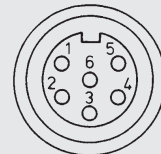

Industrial types

CONNECTION DIAGRAM

Cable PVC (A, B)	Lead	Output (R, T)	push-pull (K)	push-pull complementary (I)
red	0.5	5 VDC=	10...30 VDC=	10...30 VDC=
yellow/red	0.14	Sense V _{CC}		Sense V _{CC}
white	0.14	Channel A	Channel A	Channel \bar{A}
white/brown	0.14	Channel \bar{A}		Channel A
green	0.14	Channel B	Channel B	Channel \bar{B}
green/brown	0.14	Channel \bar{B}		Channel B
yellow	0.14	Channel N	Channel N	Channel N
yellow/brown	0.14	Channel \bar{N}		Channel \bar{N}
black	0.5	GND	GND	GND
yellow/black	0.14	Alarm/Sense GND ¹⁾	Alarm	Alarm
Screen ²⁾		Screen ²⁾	Screen ²⁾	Screen ²⁾

¹⁾ depending on ordering code

²⁾ connected to housing

ORDERING DATA

O standard	Supply voltage	Type of flange	Shaft diameter
	A 5 VDC	S synchro flange	1 6 mm
	E 10 ... 30 VDC (only push-pull)	R round flange	5 6.35 mm

RI36-0 /			3			
Number of pulses	Protection class	Output	Type of connection			
5 ... 3,600	3 IP 64	T RS 422 + Sense K push-pull short circuit proof	A cable axial B cable radial N BINDER ¹⁾ , 6 pole, axial (only push-pull) J BINDER*, 6 pole, radial (only push-pull)			
		R RS 422 + Alarm I push-pull complementary				

¹⁾ encoder connector with pins

Industrial types



- Universal industry standard encoder
- Up to 40,000 steps with 10,000 pulses
- High signal accuracy
- Protection class up to IP 67
- Operating temperature up to 100 °C (RI 58-T)
- Flexible due to many flange and configuration variants
- Suitable for high shock ratings
- Application e.g.: Machine tools, CNC axles, packing machines, motors/drives, injection moulding machines, sawing machines, textile machines
- For EX version, see RX 70-I

NUMBER OF PULSES

RI 58-O

1 / 2 / 3 / 4 / 5 / 10 / 15 / 20 / 25 / 29 / 30 / 35 / 40 / 50 / 60 / 64 / 70 / 72 / 80 / 100 / 117 / 120 / 125 / 127 / 128 / 136 / 144 / 150 / 180 / 200 / 226 / 230 / 250 / 256 / 280 / 300 / 314 / 350 / 356 / 360 / 375 / 400 / 460 / 480 / 500 / 512 / 600 / 625 / 635 / 720 / 750 / 889 / 900 / 942 / 1,000 / 1,024 / 1,125 / 1,200 / 1,250 / 1,270 / 1,500 / 1,600 / 1,800 / 1,885 / 1,979 / 2,000 / 2,048 / 2,400 / 2,500 / 3,000 / 3,400 / 3,480 / 3,600 / 3,750 / 3,925 / 3,958 / 3,968 / 4,000 / 4,096 / 4,445 / 4,800 / 5,000 / 5,400 / 6,000 / 6,875 / 7,200 / 7,680 / 7,854 / 8,000 / 8,192 / 9,000 / 10,000

other numbers of pulses available on request.

RI 58-T

(high temperature): as above, but only for the range from 4 ... 2,500 pulses
other numbers of pulses available on request.

TECHNICAL DATA mechanical

Shaft diameter	6 mm/6.35 mm/7 mm/12 mm/10 mm/9.52 mm	
Absolute max. shaft load	Ø 12 mm	180/140 N (39/30 lbs)
radial / axial	Ø 7...10 mm	160/107 N (35/24 lbs)
	Ø 6 mm/6.35 mm	110/60 N (24/13 lbs)
Absolute maximum speed	10,000 RPM	
Torque	≤ 0.5 Ncm (IP 65), ≤ 1 Ncm (IP 67)	
Moment of inertia	synchro flange 14 gcm ² approx. clamping flange 20 gcm ² approx.	
Protection class (EN 60529)	Housing IP 65, bearings IP 64 Housing IP 67, bearings IP 67	
Operating temperature	RI 58-O: -10 ... +70 °C; RI 58-T: -25 ... +100 °C	
Storage temperature	RI 58-O: -25 ... +85 °C; RI 58-T: -25 ... +100 °C	
Vibration proof (IEC 68-2-6)	100 m/s ² (10 ... 2000 Hz)	
Shock resistance (IEC 68-2-27)	1,000 m/s ² (6 ms)	
Type of connection	1.5 m cable ¹⁾ or connector, axial or radial	
Housing	aluminium Ø 58 mm	
Flange	S = synchro flange, K = clamping flange, G, Q = square flange, M = synchro clamping flange	
Weight	360 g approx.	
Bearing life	1 × 10 ¹⁰ revolutions (typ.) at 35% of full rated shaft load 1 × 10 ⁹ revolutions (typ.) at 75% of full rated shaft load 1 × 10 ⁸ revolutions (typ.) at 100% of full rated shaft load For example 30,000 h at 6,000 RPM with a 13 lb radial load (10 mm or 9.52 mm shaft)	

¹⁾ Other cable lengths on request

Industrial types

TECHNICAL DATA
electrical

General design	as per DIN VDE 0160, protection class III, contamination level 2, overvoltage class II		
Supply voltage (SELV)	with RS 422 + Sense (T):	5 VDC \pm 10 %	
	with RS 422 + Alarm (R):	5 VDC \pm 10 % oder 10 ... 30 VDC ¹⁾	
	with push-pull (K, I):	10 ... 30 VDC ¹⁾	
Power consumption	40 mA (5 VDC), 60 mA (10 VDC), 30 mA (24 VDC)		
Standard-Output versions ²⁾	RS 422 (R):	A, B, N, \bar{A} , \bar{B} , \bar{N} , \bar{Alarm}	
	RS 422 (T):	A, B, N, \bar{A} , \bar{B} , \bar{N} , Sense	
	push-pull (K):	A, B, N, \bar{Alarm}	
	push-pull complementary (I):	A, B, N, \bar{A} , \bar{B} , \bar{N} , \bar{Alarm}	

¹⁾ Pole protection with supply voltage 10...30 VDC

²⁾ Output description and technical data see section „output“.

CONNECTION DIAGRAM
CABLE PVC

cable PVC (A, B)	Output (R, T)	push-pull (K)	push-pull complementary (I)
red	5/10...30 VDC=	10...30 VDC=	10...30 VDC=
yellow/red	Sense V_{CC}		Sense V_{CC}
white	Channel A	Channel A	Channel A
white/brown	Channel \bar{A}		Channel \bar{A}
green	Channel B	Channel B	Channel B
green/brown	Channel \bar{B}		Channel \bar{B}
yellow	Channel N	Channel N	Channel N
yellow/brown	Channel \bar{N}		Channel \bar{N}
black	GND	GND	GND
yellow/black	Alarm/Sense GND ¹⁾	Alarm	Alarm
Screen ²⁾	Screen ²⁾	Screen ²⁾	Screen ²⁾

¹⁾ depending on ordering code

²⁾ connected to housing

CONNECTION DIAGRAM
CABLE TPE

cable TPE (E, F)	Output (R, T)	push-pull (K)	push-pull complementary (I)
brown/green	5/10...30 VDC=	10...30 VDC=	10...30 VDC=
blue	Sense V_{CC}		Sense V_{CC}
brown	Channel A	Channel A	Channel A
green	Channel \bar{A}		Channel \bar{A}
grey	Channel B	Channel B	Channel B
pink	Channel \bar{B}		Channel \bar{B}
red	Channel N	Channel N	Channel N
black	Channel \bar{N}		Channel \bar{N}
white/green	GND	GND	GND
violet (white) ¹⁾	Alarm/Sense GND ²⁾	Alarm	Alarm
Screen ³⁾	Screen ³⁾	Screen ³⁾	Screen ³⁾

¹⁾ white for RS 422 + Sense (T)

²⁾ depending on ordering code

³⁾ connected to housing

Industrial types

CONNECTOR 12 POLE (CONIN)

Pin	RS 422 + Sense (T)	RS 422 + Alarm (R)	push-pull (K)	push-pull complementary
1	Channel B	Channel B	N.C.	Channel B
2	Sense V _{CC}	Sense V _{CC}	N.C.	Sense V _{CC}
3	Channel N	Channel N	Channel N	Channel N
4	Channel N	Channel N	N.C.	Channel N
5	Channel A	Channel A	Channel A	Channel A
6	Channel A	Channel A	N.C.	Channel A
7	N.C.	Alarm	Alarm	Alarm
8	Channel B	Channel B	Channel B	Channel B
9	N.C. ¹⁾	N.C. ¹⁾	N.C. ¹⁾	N.C. ¹⁾
10	GND	GND	GND	GND
11	Sense GND	N.C.	N.C.	N.C.
12	5 VDC =	5/10...30 VDC =	10...30 VDC =	10...30 VDC =

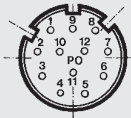

Pin-assignment
connector counter
clockwise (ccw)

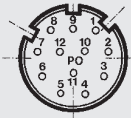

connector
clockwise (cw)

¹⁾ Screen for cable with CONIN connector

CONNECTOR 10 POLE (MIL)

Pin	RS 422/Push-pull complementary Euro-pinout (connection codes O and K)	Push-pull (O and K)	RS 422/Push-pull complementary US-pinout (R and T)
1/A	Channel A	Channel A	Channel A
2/B	Channel B	Channel B	Channel B
3/C	Channel N	Channel N	Channel N
4/D	5/10...30 VDC =	10...30 VDC =	5/10...30 VDC =
5/E	Alarm	Alarm	Alarm
6/F	GND	GND	GND
7/G	Channel A	Screen	Screen
8/H	Channel B	N.C.	Channel A
9/I	Channel N	N.C.	Channel B
10/J	Screen	Screen	Channel N

CONNECTOR 6/7 POLE (MIL)

	MIL 6 pole	MIL 7 pole
Pin	Push-pull	Push-pull
1/A	10...30 VDC	Channel A
2/B	Channel A	Channel B
3/C	Channel B	Channel N
4/D	Channel N	10...30 VDC =
5/E	GND	Alarm
6/F	Screen	GND
7/G	-	Screen

CONNECTOR 6 POLE (BINDER)

Description (push-pull)	Pin
10 ... 30 VDC	1
Channel A	2
Channel N	3
Channel B	4
Alarm	5
GND	6



DIMENSIONED DRAWINGS

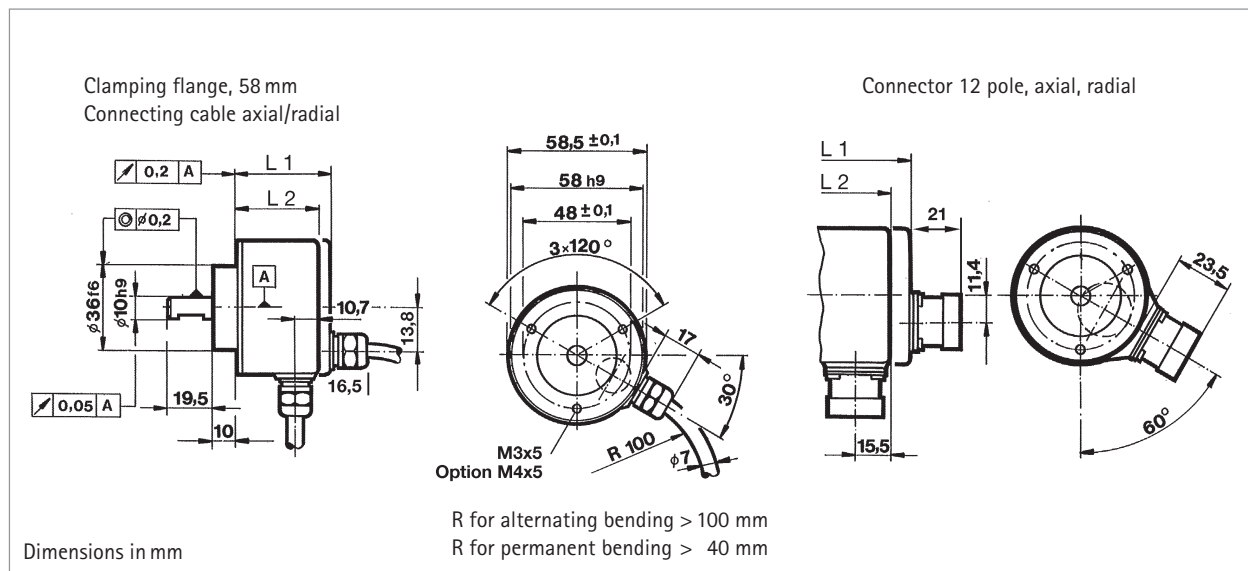
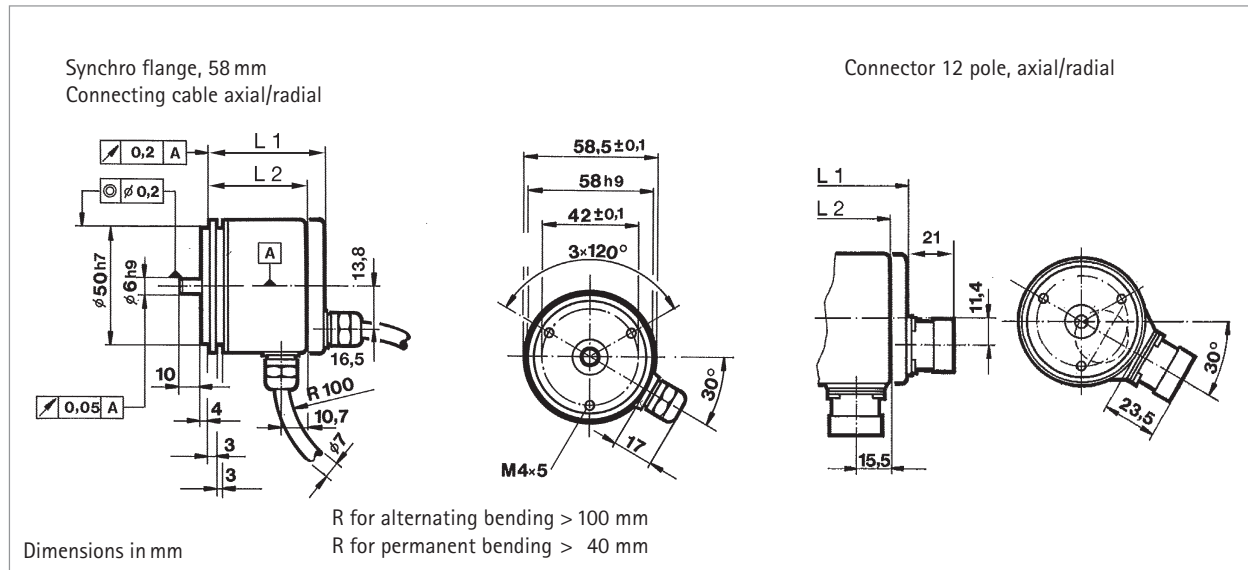

DIMENSIONS

Type	Connection	Output ¹⁾	axial L ₁	radial L ₂
Synchro flange, 58 mm	cable	R (with U _B = 5 V), T, K, I	51.5	41.5
		R (with U _B = 10...30 V)	56	56
	connector	R (with U _B = 5 V), T, K, I	57.5	51.5
		R (with U _B = 10...30 V)	57.5	56
Clamping flange, 58 mm	cable	R (with U _B = 5 V), T, K, I	45.5	35.5
		R (with U _B = 10...30 V)	50	50
	connector	R (with U _B = 5 V), T, K, I	51.5	45.5
		R (with U _B = 10...30 V)	51.5	50

¹⁾ R = RS 422 + Alarm, T = RS 422 + Sense, K = push-pull, I = push-pull complementary

Incremental Shaft Encoders Type RI 58

Industrial types

DIMENSIONED DRAWINGS

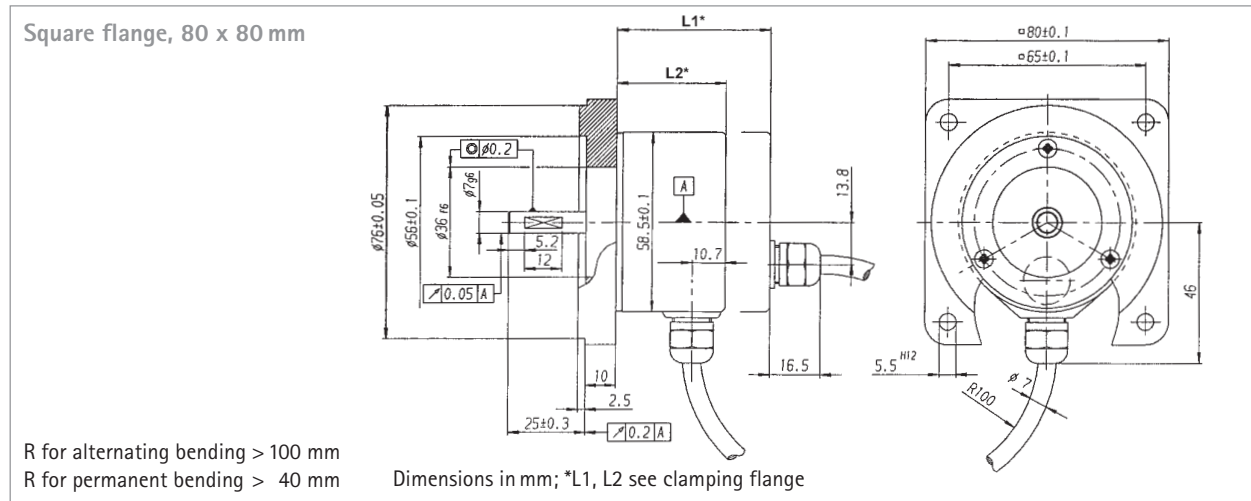
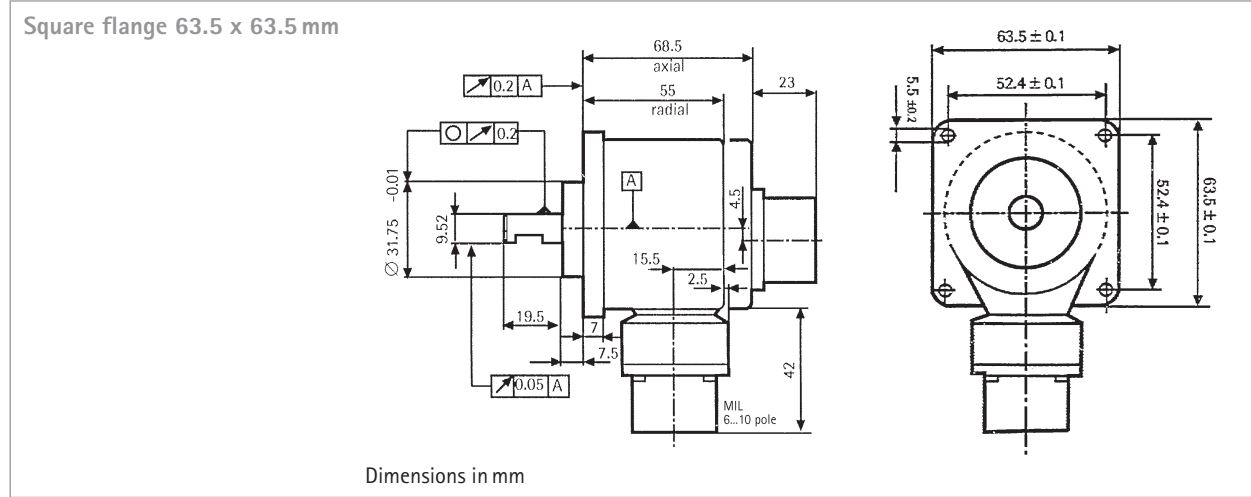
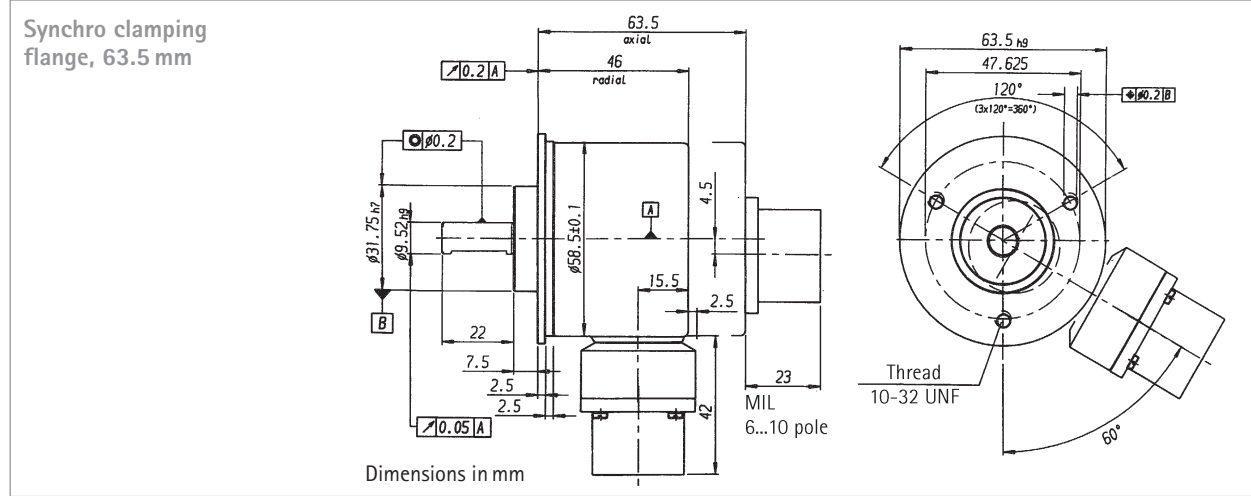

Incremental Shaft Encoders

Industrial types

Type RI 58

STANDARD VERSIONS

Guide for selection of RI 58-O

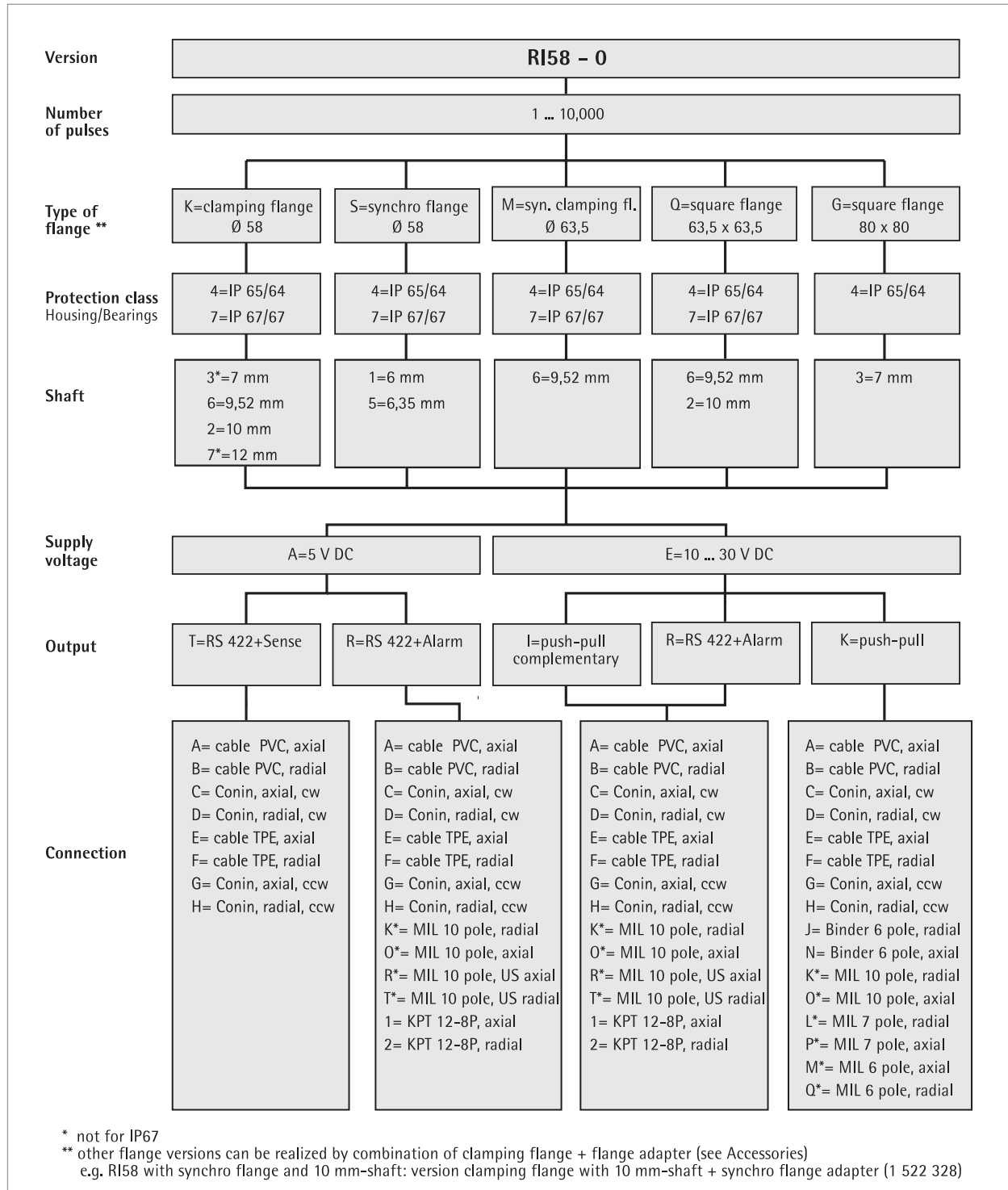

Incremental Shaft Encoders

Industrial types

Type RI 58

STANDARD VERSIONS

Guide for selection of RI 58-T

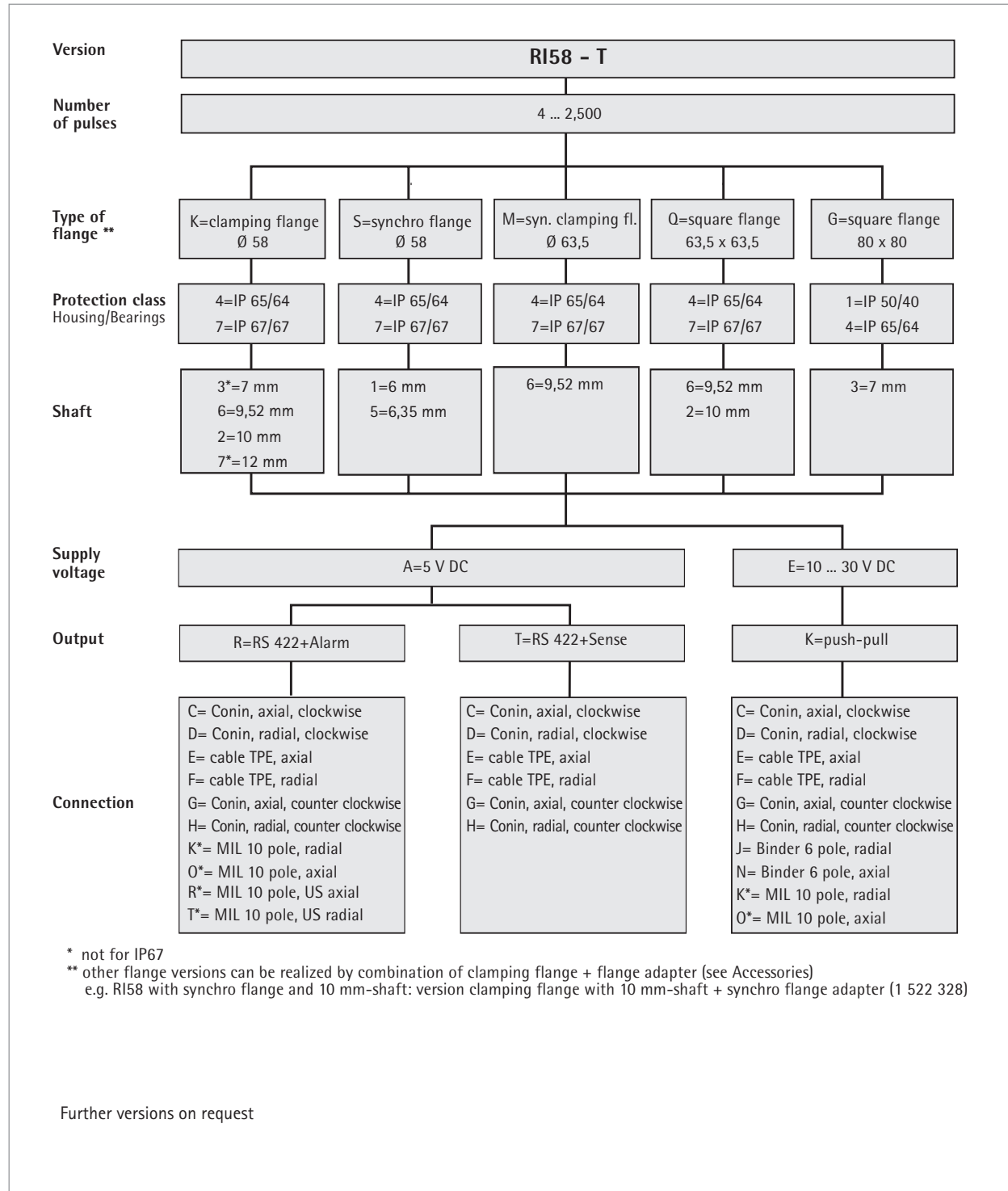

Industrial types

ORDERING DATA

Please check „selection guide“ on previous pages as not all combinations are possible!

O standard	Supply voltage	Type of flange	Shaft diameter
T high temperature	A 5 VDC	S synchro flange	1 6 mm
	E 10 ... 30 VDC	K clamping flange	2 10 mm
		G square flange 80 x 80	3 7 mm
		Q square flange 63.5 x 63.5	5 6.35 mm
		M synchro clamping flange	6 9.52 mm
			7 12 mm

RI 58 -	/			.			
Number of pulses	Protection class	Output					
RI58-O: 1 ... 10,000	4 IP 64	T RS 422 + Sense					
RI58-T: 4 ... 2,500	7 IP 67	K push-pull, short circuit proof					
		I push-pull complementary					
		R RS 422+Alarm					

Type of connection	O MIL MS ¹⁾ , 10 pole, axial
A PVC-cable axial ²⁾	K MIL MS ¹⁾ , 10 pole, radial
B PVC-cable radial	L MIL ¹⁾ 7 pole, radial
C CONIN ¹⁾ , axial clockwise	P MIL 7 pole, axial
D CONIN ¹⁾ , radial clockwise	MMIL 6 pole, axial
E TPE-cable axial	Q MIL 6 pole, radial
F TPE-cable radial	R MIL 10 pole, U.S. axial ³⁾
G CONIN ¹⁾ , axial counter clockwise	T MIL 10 pole, U.S. radial ³⁾
H CONIN ¹⁾ , radial counter clockwise	1 KPT 12-8 P, axial
J BINDER ¹⁾ 6 pole, radial	2 KPT 12-8 P, radial
N BINDER ¹⁾ 6 pole, axial	

¹⁾ encoder connector with pins ³⁾ U.S. pinout
²⁾ European pinout

ACCESSORIES

Clamping eccentric (set of three)
Ordering code 0 070 655

Spring washer coupling hole 6/6 mm
Ordering code 3 520 081

hole 10/10 mm
Ordering code 3 520 088

Cable plug connector for connector (CONIN), clockwise (type of connection C, D)
Ordering code 3 539 202

for connector (CONIN), counter clockwise (type of connection G, H)
Ordering code 3 539 229

Mounting spanner for CONIN connectors
Ordering code 3 539 343

Extension cables (TPE)		
12-pin plug (socket) on one end	clockwise (C, D)	counter clockwise (G, H)
	Ordering code	Ordering code
L = 3 m	1 522 348	1 522 394
L = 5 m	1 522 349	1 522 395
L = 10 m	1 522 350	1 522 396
TPE-cable (not made up with connectors)	3 280 112 + state required length	
For more detailed specifications and other accessories see "Accessories"		

Downloaded from Elcodis.com electronic components distributor

Incremental Shaft Encoders Type RI 59

Industrial types Stainless Steel

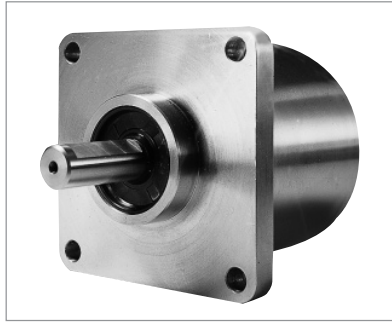

NUMBER OF PULSES

- Stainless steel encoder with high protection class
- High corrosion resistance
- Use in the area of food production or if sea-water proof is required
- Application e.g.:
 - packing machines
 - bottling machines
 - washing plants
 - mixers
 - cranes
 - hoists
 - marine outfitters

1 / 2 / 3 / 4 / 5 / 10 / 15 / 20 / 25 / 29 / 30 / 35 / 40 / 50 / 60 / 64 / 70 / 72 / 80 / 100 / 117 / 120 / 125 / 127 / 128 / 136 / 144 / 150 / 180 / 200 / 226 / 230 / 250 / 256 / 280 / 300 / 314 / 350 / 356 / 360 / 375 / 400 / 460 / 480 / 500 / 512 / 600 / 625 / 635 / 720 / 750 / 889 / 900 / 942 / 1,000 / 1,024 / 1,125 / 1,200 / 1,250 / 1,270 / 1,500 / 1,600 / 1,800 / 1,885 / 1,979 / 2,000 / 2,048 / 2,400 / 2,500 / 3,000 / 3,400 / 3,480 / 3,600 / 3,750 / 3,925 / 3,958 / 3,968 / 4,000 / 4,096 / 4,445 / 4,800 / 5,000 / 5,400 / 6,000 / 6,875 / 7,200 / 7,680 / 7,854 / 8,000 / 8,192 / 9,000 / 10,000

Other numbers of pulses available on request.

TECHNICAL DATA mechanical

Shaft diameter	9.52 mm/10 mm
Absolute max. shaft load	radial 160 N / axial 107 N (35/24 lbs)
Absolute maximum speed	10,000 RPM
Torque	≤ 1 Ncm
Moment of inertia	ca. 20 gcm ²
Protection class (EN 60529)	Housing IP 67, bearings IP 67
Operating temperature	-10 ... +70 °C
Storage temperature	-25 ... +85 °C
Vibration proof (IEC 68-2-6)	100 m/s ² (10 ... 2000 Hz)
Shock resistance (IEC 68-2-27)	1,000 m/s ² (6 ms)
Type of connection	1.5 m cable ¹⁾ radial or axial
Housing	stainless steel Ø 58 mm
Flange	Q= square flange 63.5 x 63.5 mm
Weight	approx. 620 g
Bearing life	1 x 10 ¹⁰ revolutions (typ.) at 35% of full rated shaft load 1 x 10 ⁹ revolutions (typ.) at 75% of full rated shaft load 1 x 10 ⁸ revolutions (typ.) at 100% of full rated shaft load For example 30,000 h at 6,000 RPM with a 13 lb radial load

¹⁾ Other cable length on request

Incremental Shaft Encoders Type RI 59

Industrial types

TECHNICAL DATA electrical

General design	as per DIN VDE 0160, protection class III, contamination level 2, overvoltage class II	
Supply voltage (SELV)	with RS 422 + Sense (T):	5 VDC \pm 10 %
	with RS 422 + Alarm (R):	5 VDC \pm 10 % or 10 ... 30 VDC ¹⁾
	with push-pull (K, I):	10 ... 30 VDC ¹⁾
Power consumption	40 mA (5 VDC), 60 mA (10 VDC), 30 mA (24 VDC)	
Standard- Output versions ²⁾	RS 422 (R):	A, B, N, \bar{A} , \bar{B} , \bar{N} , \bar{Alarm}
	RS 422 (T):	A, B, N, \bar{A} , \bar{B} , \bar{N} , Sense
	push-pull (K):	A, B, N, \bar{Alarm}
	push-pull complementary (I):	A, B, N, \bar{A} , \bar{B} , \bar{N} , \bar{Alarm}

¹⁾ Pole protection with supply voltage 10 ... 30 VDC

²⁾ Output description and technical data see section „output“

DIMENSIONED DRAWING

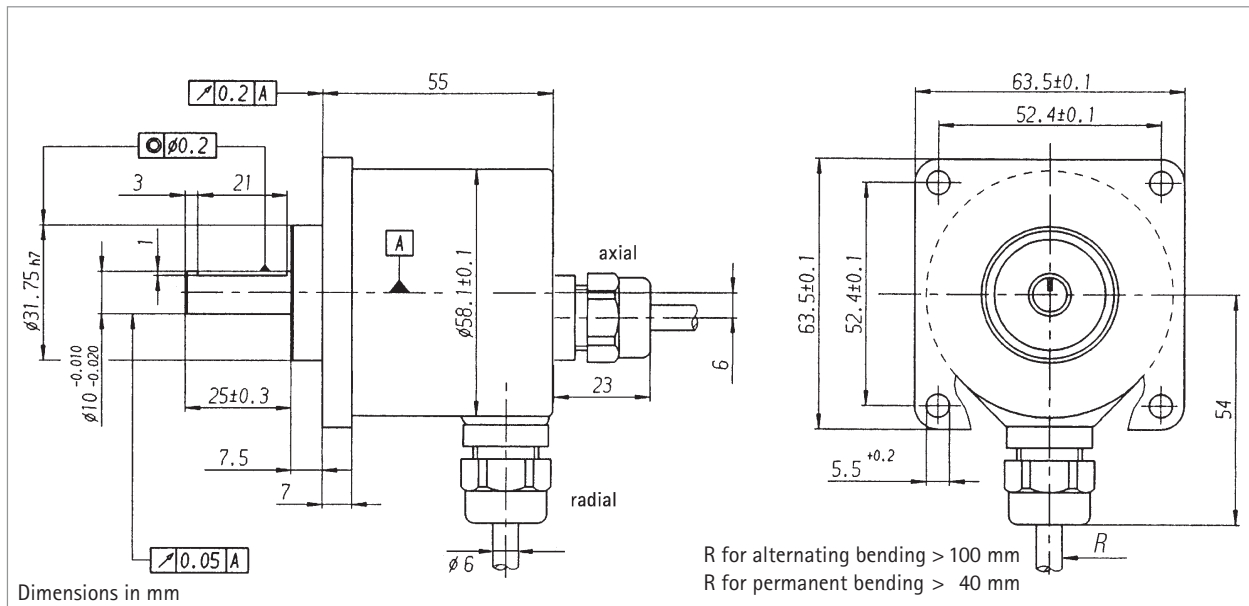

Incremental Shaft Encoders Type RI 59

Industrial types

CONNECTION DIAGRAM

Connection cable		Output	
Colour	Lead Ø mm ²	RS 422	push-pull
		T and R	K and I
red	0.5 mm ²	5/10...30 VDC	10 ... 30 VDC
red/yellow	0.14 mm ²	Sense V _{CC}	Sense V _{CC}
white	0.14 mm ²	Channel A	Channel A
white/brown	0.14 mm ²	Channel \bar{A}	Channel \bar{A} ¹⁾
green	0.14 mm ²	Channel B	Channel B
green/brown	0.14 mm ²	Channel \bar{B}	Channel \bar{B} ¹⁾
yellow	0.14 mm ²	Channel N	Channel N
yellow/brown	0.14 mm ²	Channel \bar{N}	Channel \bar{N} ¹⁾
black	0.5 mm ²	GND	GND
black/yellow	0.14 mm ²	Alarm/Sense GND ²⁾	Alarm
screen ³⁾		screen ³⁾	screen ³⁾

¹⁾ only push-pull complementary (I)

²⁾ depending on ordering code

³⁾ connected to housing

ORDERING DATA

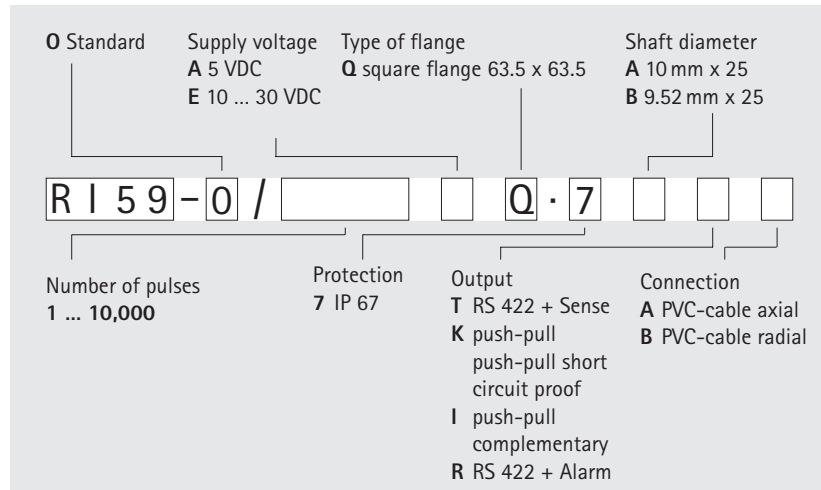

Incremental Shaft Encoders Type RX 70 TI

Industrial types

EX



- Encoder for explosion-protection type II
- Top reliability
- Application e.g.:
 - enamelling production lines
 - finishing machines
 - bottling machines
 - mixers
 - silo works
- For absolute EX encoders, see "Absolute Encoders Type RX 70-TS, TM, TP"



NUMBER OF PULSES

1 / 2 / 3 / 4 / 5 / 10 / 15 / 20 / 25 / 29 / 30 / 35 / 40 / 50 / 60 / 64 / 70 / 72 / 80 / 100 / 117 / 120 / 125 / 127 / 128 / 136 / 144 / 150 / 180 / 200 / 226 / 230 / 250 / 256 / 280 / 300 / 314 / 350 / 356 / 360 / 375 / 400 / 460 / 480 / 500 / 512 / 600 / 625 / 635 / 720 / 750 / 889 / 900 / 942 / 1,000 / 1,024 / 1,125 / 1,200 / 1,250 / 1,270 / 1,500 / 1,600 / 1,800 / 1,885 / 1,979 / 2,000 / 2,048 / 2,400 / 2,500 / 3,000 / 3,400 / 3,480 / 3,600 / 3,750 / 3,925 / 3,958 / 3,968 / 4,000 / 4,096 / 4,445 / 4,800 / 5,000 / 5,400 / 6,000 / 6,875 / 7,200 / 7,680 / 7,854 / 8,000 / 8,192 / 9,000 / 10,000

Other numbers of pulses available on request.

EX-CLASSIFICATION

Hengstler EXPLOSION-PROOF shaft encoders are classified according to EEx d IIC T6/T4 (according to EN 50014 and EN 50018)
Certificate of conformity: BVS 95.D.2027

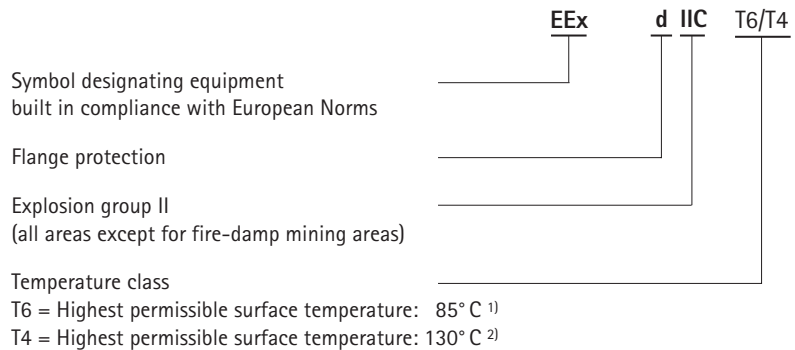

¹⁾ EEx d IIC T6: max. speed = 6,000 RPM

²⁾ EEx d IIC T4: max. speed = 10,000 RPM

Incremental Shaft Encoders Type RX 70 TI

Industrial types

EX

TECHNICAL DATA mechanical

Shaft diameter	10 mm
Absolute max. shaft load	radial 160 N / axial 107 N (35/24 lbs)
Absolute maximum speed	10,000 RPM (EEx d IIC T4) 6,000 RPM (EEx d IIC T6)
Torque	≤ 1 Ncm
Moment of inertia	ca. 20 gcm ²
Protection class (EN 60529)	Housing IP 65, bearings IP 64
Operating temperature	-20 ... +60 °C (EEx d IIC T4) -10 ... +40 °C (EEx d IIC T6)
Storage temperature	-25 ... +85 °C
Vibration proof (IEC 68-2-6)	10 g = 100 m/s ² (10...2,000 Hz)
Shock resistance (IEC 68-2-27)	100 g = 1,000 m/s ² (6 ms)
Type of connection	5 m cable axial ¹⁾ for fixed layout
Size	Ø 70 mm
Flange	Clamping flange, holes 3 x M6
Weight	approx. 1,400 g
Bearing life	1 x 10 ¹⁰ revolutions (typ.) at 35% of full rated shaft load 1 x 10 ⁹ revolutions (typ.) at 75% of full rated shaft load 1 x 10 ⁸ revolutions (typ.) at 100% of full rated shaft load For example 30,000 h at 6,000 RPM with a 13 lb radial load (10 mm or 9.52 mm shaft)

¹⁾ Other cable lengths on request

TECHNICAL DATA electrical

General design	as per DIN VDE 0160, protection class III, contamination level 2, overvoltage class II
Supply voltage (SELV)	with RS 422 + Sense (T): 5 VDC ± 10% with RS 422 + Alarm (R): 5 VDC ± 10% oder 10 ... 30 VDC ¹⁾ with push-pull (K, I): 10 ... 30 VDC ¹⁾
Power consumption	40 mA (5 VDC), 60 mA (10 VDC), 30 mA (24 VDC)
Standard- Output versions ²⁾	RS 422 (R): A, B, N, \bar{A} , \bar{B} , \bar{N} , Alarm RS 422 (T): A, B, N, \bar{A} , \bar{B} , \bar{N} , Sense push-pull (K): A, B, N, Alarm push-pull complementary (I): A, B, N, \bar{A} , \bar{B} , \bar{N} , Alarm

¹⁾ Pole protection with supply voltage 10 ... 30 VDC

²⁾ Output description and technical data see section „output“.

DIMENSIONED DRAWING

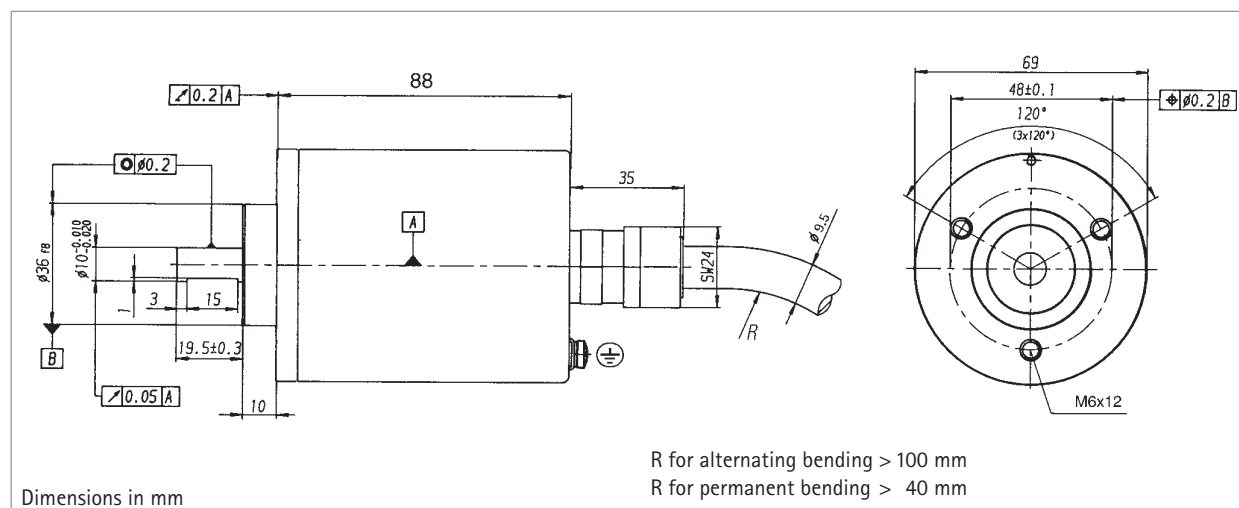

Incremental Shaft Encoders Type RX 70 TI

Industrial types

EX

CONNECTION DIAGRAM

Cable No.	Output			
	RS 422+ Sense (T)	RS 422+ Alarm (R)	push-pull (K)	push-pull complementary (I)
12	5 VDC	5/10...30 VDC	10...30 VDC	10...30 VDC
11	GND	GND	GND	GND
10	Sense V _{cc}			
9	Sense GND			
1	Channel A	Channel A	Channel A	Channel A
2	Channel \bar{A}	Channel \bar{A}		Channel \bar{A}
3	Channel B	Channel B	Channel B	Channel B
4	Channel \bar{B}	Channel \bar{B}		Channel \bar{B}
5	Channel N	Channel N	Channel N	Channel N
6	Channel \bar{N}	Channel \bar{N}		Channel \bar{N}
7		Alarm	Alarm	Alarm
screen	Cable screen connected to housing			
Screw terminal	for additional connection of an earth conductor			

ORDERING DATA

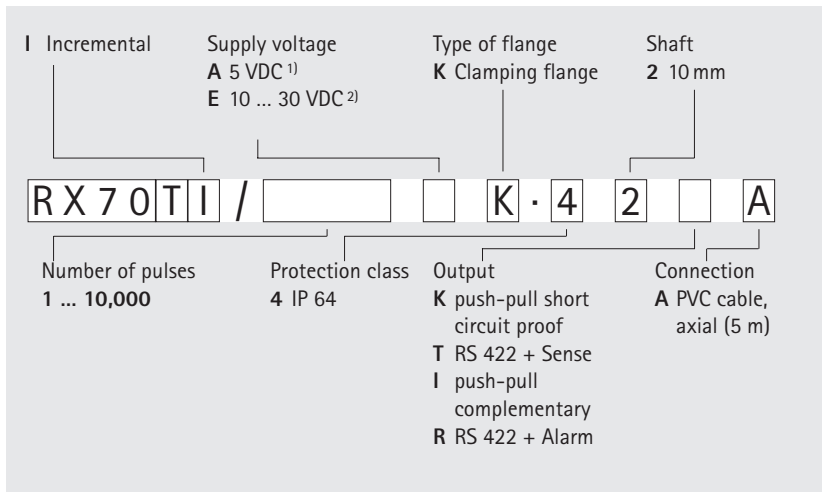

¹⁾ with output T, R

²⁾ with output K, I, R

Incremental Encoder with Hollow Shaft

Type RI 36-H



- miniature industry encoder for high number of pulses
- short mounting length
- easy mounting procedure
- Application e.g.:
 - Motors
 - Machine tools
 - Packaging Machines
 - Robots
 - Automated SMD equipment

NUMBER OF PULSES

5 / 10 / 20 / 25 / 50 / 60 / 100 / 200 / 250 / 300 / 360 / 500 / 600 / 720 / 1000 / 1024 / 1250 / 1500 / 2000 / 2048 / 2500 / 3000 / 3600
Other number of pulses available on request

TECHNICAL DATA mechanical

Mounting	Clamping shaft (one side open) with front clamping ring
Coupling	spring plate
Shaft diameter	4, 6, 8, 10 mm hollow shaft
Angular shaft misalignment max.	$\pm 0,15$ mm radial, $\pm 0,5$ mm axial
Absolute max. speed	max. 10.000 min ⁻¹
Torque	≤ 1 Ncm
Moment of inertia	ca. 3 gcm ²
Protection class (EN 60529)	Housing IP 64, bearings IP 64
Operating temperature	-10...+70 °C
Storage temperature	-25 ... +85 °C
Vibration performance	100 m/s ² (10...2000 Hz)
Shock resistance	1000 m/s ² (6 ms)
Type of connection	1,5 m cable ¹⁾ axial or radial
Housing	aluminium
Weight	ca. 80 g

¹⁾ other cable length on request

TECHNICAL DATA electrical

General design	as per DIN EN61010-1, protection class III, contamination level 2, overvoltage class II	
Supply voltage (SELV)	with RS 422 (R, T):	5 VDC 10 %
	with push-pull (K, I):	10 ... 30 VDC ¹⁾
Power consumption	40 mA (5 VDC), 60 mA (10 VDC), 30 mA (24 VDC)	
Standard-Output version ²⁾	RS 422 (R):	A, B, N, \bar{A} , \bar{B} , \bar{N} , Alarm
	RS 422 (T):	A, B, N, \bar{A} , \bar{B} , \bar{N} , Sense
	push-pull (K):	A, B, N, Alarm
	push-pull complementary (I):	A, B, N, \bar{A} , \bar{B} , \bar{N} , Alarm

¹⁾ pole protection

²⁾ Output description and technical data see section "output"

Incremental Encoder with Hollow Shaft

Type RI 36-H

DIMENSIONED DRAWING

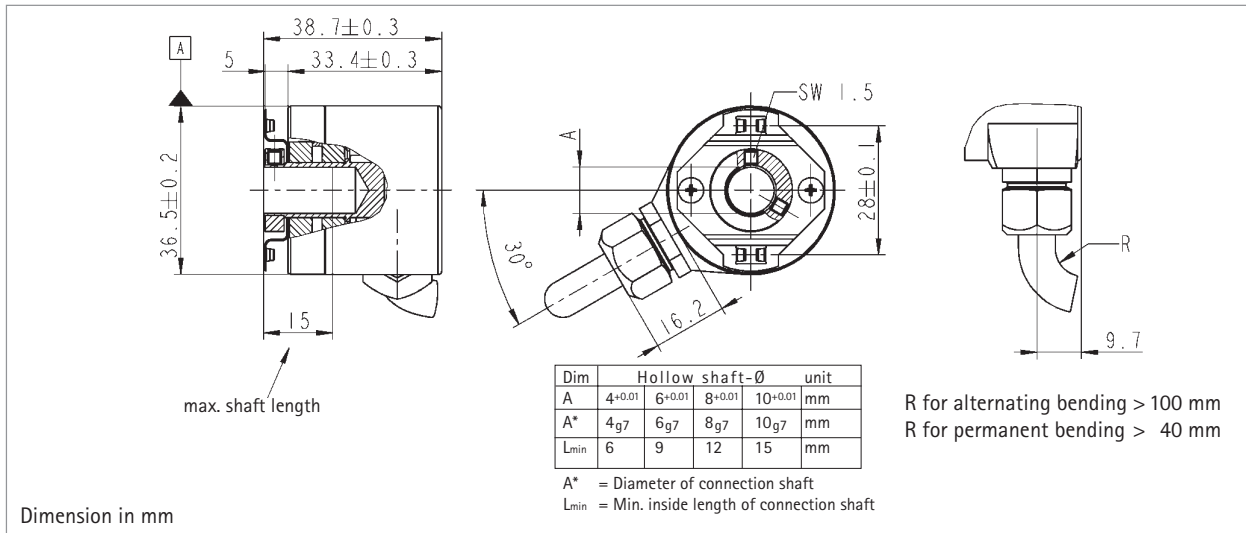

The spring plate as torque support must be fixed by a cylindrical pin (2.4 mm Ø) at the machine side

CONNECTION DIAGRAM

Cable PVC (A, B)	Lead Ø	Output (R, T)	push-pull (K)	push-pull complementary (I)
red	0.5	5 VDC=	10...30 VDC=	10...30 VDC=
yellow/red	0.14	Sense V _{CC}	Sense V _{CC}	
white	0.14	Channel A	Channel A	Channel A
white/brown	0.14	Channel \bar{A}		Channel \bar{A}
green	0.14	Channel B	Channel B	Channel B
green/brown	0.14	Channel \bar{B}		Channel \bar{B}
yellow	0.14	Channel N	Channel N	Channel N
yellow/brown	0.14	Channel \bar{N}		Channel \bar{N}
black	0.5	GND	GND	GND
yellow/black	0.14	Alarm/Sense GND ¹⁾	Alarm	Alarm
Screen ²⁾		Screen ²⁾	Screen ²⁾	Screen ²⁾

¹⁾ depending on ordering code

²⁾ connected to housing

ORDERING DATA

H Hollow shaft	Supply voltage	Mounting	Shaft diameter
	A 5 VDC	F clamping shaft	Ø 4 mm
	E 10 ... 30 VDC (push-pull only)		1 6 mm
			C 8 mm
			2 10 mm

Number of pulses	Protection class	Output	Type of connection
5 ... 3600	3 IP 64	T RS 422 + Sense	A Cable axial
		K push-pull short circuit proof	B Cable radial
		R RS 422 + Alarm	
		I push-pull complementary	

Incremental Shaft Encoders Type RI 58-H with Hollow Shaft



NUMBER OF PULSES

- Through shaft
- High accuracy by means of integrated flexible coupling
- Safe shaft mounting
- Application e.g.:
 - textile machines
 - motors
 - drives
 - copiers

1 / 2 / 3 / 4 / 5 / 10 / 15 / 20 / 25 / 29 / 30 / 35 / 50 / 60 / 70 / 72 / 80 / 100 / 117 / 120 / 125 / 128 / 136 / 144 / 150 / 180 / 200 / 226 / 230 / 250 / 256 / 280 / 300 / 314 / 350 / 360 / 375 / 400 / 460 / 480 / 500 / 512 / 600 / 720 / 900 / 1,000 / 1,024 / 1,250 / 1,270 / 1,500 / 1,600 / 1,800 / 1,885 / 2,000 / 2,048 / 2,400 / 2,500 / 3,000 / 3,400 / 3,480 / 3,600 / 3,925 / 4,000 / 4,096 / 5,000

Other numbers of pulses available on request

TECHNICAL DATA mechanical

Shaft diameter	10 mm hollow shaft 12 mm hollow shaft Required dimension of mounting shaft: Ø 10 mm, tolerance g8 (-0.005 ... -0.027 mm) Ø 12 mm, tolerance g8 (-0.006 ... -0.033 mm)
Balance tolerances	Misalignment axial ± 0.4 mm Misalignment parallel 0.4 mm Misalignment angular 1°
Absolute maximum speed	max. 3,000 RPM
Torque	≤ 2 Ncm (IP 64)
Moment of inertia	approx. 65 gcm ² (10 mm shaft) approx. 95 gcm ² (12 mm shaft)
Protection class (EN 60529)	Housing IP 64, bearings IP 64
Operating temperature	-10 ... +70 °C
Storage temperature	-25 ... +85 °C
Vibration proof (IEC 68-2-6)	10 g = 100 m/s ² (10 ... 2 kHz)
Shock resistance (IEC 68-2-27)	100 g = 1,000 m/s ² (6 ms)
Type of connection radial	cable, 1.5 m ¹⁾
Housing	aluminium
Flange	synchro flange
Weight	210 g approx.

¹⁾ Other cable length on request

Incremental Shaft Encoders Type RI 58-H with Hollow Shaft

TECHNICAL DATA electrical

General design	as per DIN VDE 0160, protection class III, contamination level 2, overvoltage class II	
Supply voltage	with RS 422 + Sense (T):	5 VDC \pm 10 %
	with RS 422 + Alarm (R):	5 VDC \pm 10 % oder 10 ... 30 VDC ¹⁾
(SELV)	with push-pull (K, I):	10 ... 30 VDC ¹⁾
Power consumption	40 mA (5 VDC), 60 mA (10 VDC), 30 mA (24 VDC)	
Standard- Output versions ²⁾	RS 422 (R):	A, B, N, \bar{A} , \bar{B} , \bar{N} , \bar{Alarm}
	RS 422 (T):	A, B, N, \bar{A} , \bar{B} , \bar{N} , Sense
	push-pull (K):	A, B, N, \bar{Alarm}
	push-pull complementary (I):	A, B, N, \bar{A} , \bar{B} , \bar{N} , \bar{Alarm}

¹⁾ Pole protection with supply voltage 10...30 VDC

²⁾ Output description and technical data see section "output".

DIMENSIONED DRAWING

Synchro flange

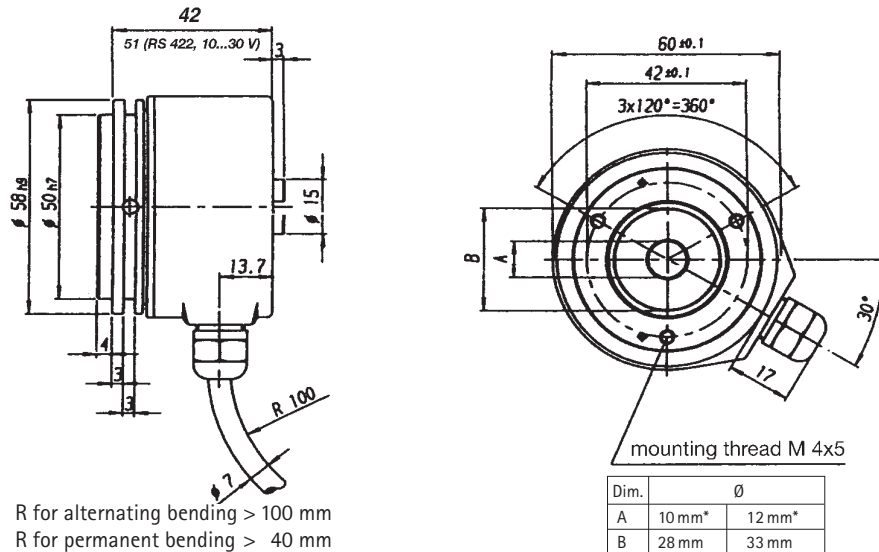

Dimensions in mm

Incremental Shaft Encoders Type RI 58-H with Hollow Shaft

CONNECTION DIAGRAM

Connection cable		Output	
Colour	Lead \varnothing mm ²	RS 422 T and R	push-pull K and I
red	0.5 mm ²	5/10...30 VDC	10...30 VDC
red/yellow	0.14 mm ²	Sense V _{CC}	Sense V _{CC}
white	0.14 mm ²	Channel A	Channel A
white/brown	0.14 mm ²	Channel \bar{A}	Channel \bar{A} ¹⁾
green	0.14 mm ²	Channel B	Channel B
green/brown	0.14 mm ²	Channel \bar{B}	Channel \bar{B} ¹⁾
yellow	0.14 mm ²	Channel N	Channel N
yellow/brown	0.14 mm ²	Channel \bar{N}	Channel \bar{N} ¹⁾
black	0.5 mm ²	GND	GND
black/yellow	0.14 mm ²	Alarm/Sense GND ²⁾	Alarm
screen ³⁾		screen ³⁾	screen ³⁾

¹⁾ only push-pull complementary (I)

²⁾ depending on ordering code

³⁾ connected to housing

ORDERING DATA

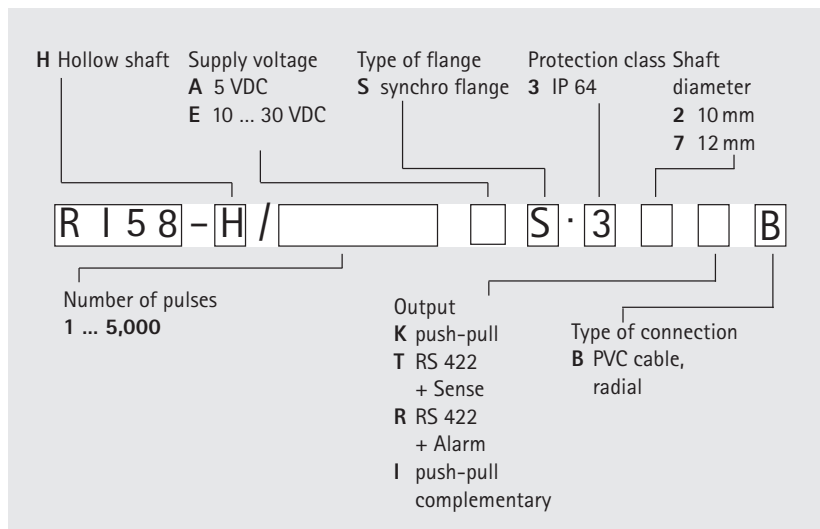

ACCESSORIES

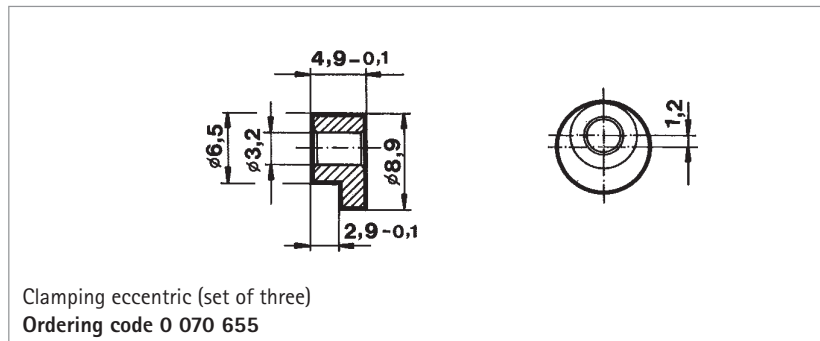

Incremental Shaft Encoders Type RI 58-D with Hollow Shaft



Blind shaft



Clamping shaft

- Flexible hollow shaft design up to diameter 14 mm
- Short overall length
- Easy installation by means of clamping shaft or blind shaft
- Application e.g.:
 - actuators
 - length measuring machines
 - motors
- Operating temperature up to 100 °C (RI 58 TD)

NUMBER OF PULSES RI 58-D

1 / 2 / 3 / 4 / 5 / 10 / 20 / 25 / 29 / 30 / 35 / 40 / 45 / 50 / 60 / 64 / 70 / 72 / 80 / 100 / 117 / 120 / 125 / 128 / 136 / 144 / 150 / 160 / 180 / 200 / 226 / 230 / 250 / 256 / 280 / 300 / 314 / 350 / 360 / 375 / 400 / 460 / 480 / 500 / 512 / 600 / 625 / 720 / 889 / 900 / 942 / 1000 / 1024 / 1250 / 1270 / 1500 / 1600 / 1800 / 1885 / 2000 / 2048 / 2400 / 2500 / 3000 / 3400 / 3480 / 3600 / 3925 / 4000 / 4096 / 5000

RI 58 TD

(high temperature); As above, but only within the range 4...2,500
Other numbers of pulses available on request

SHAFT VARIANTS

E = End shaft (non-through shaft)
F = Clamping shaft (non-through shaft)
D = Clamping shaft (through shaft)

TECHNICAL DATA
mechanical

Mounting	synchro flange with clamping shaft or blind shaft
Shaft diameter	hollow shaft 10 mm hollow shaft 12 mm hollow shaft 14 mm (not through) required dimension of mounting shaft: Ø 10 mm, tolerance g8 (-0.005...-0.027 mm) Ø 12/14 mm, tolerance g8 (-0.006...-0.033 mm)
Absolute maximum speed	E, F: max. 6,000 RPM; D = max. 4000 min ⁻¹
Torque	≤ 1 Ncm with non-through shaft (E, F) ≤ 2 Ncm with through shaft D
Moment of inertia	F: approx. 35 gcm ² (clamping non-through shaft) E: approx. 20 gcm ² (end shaft) D: approx 60 gcm ² (clamping through shaft)
Protection class (EN 60529)	E, F: housing IP 65, bearings IP 64 D: housing IP 64, bearings IP 64
Operating temperature	-10 ... +70 °C, Option: -25 ...+100°C
Storage temperature	-25 ... +85 °C
Vibration proof (IEC 68-2-6)	10 g = 100 m/s ² (10 ... 2,000 Hz)
Shock resistance (IEC 68-2-27)	100 g = 1,000 m/s ² (6 ms)
Type of connection radial	1.5 m cable ¹⁾ or connector
Housing	aluminium
Weight	E, F: 170 g approx.; D: 190 g approx.

¹⁾ Other cable length on request

Incremental Shaft Encoders Type RI 58-D with Hollow Shaft

TECHNICAL DATA electrical

General design	as per DIN VDE 0160, protection class III, contamination level 2, overvoltage class II	
Supply voltage (SELV)	with RS 422 + Sense (T):	5 VDC ± 10 %
	with RS 422 + Alarm (R):	5 VDC ± 10 % oder 10 ... 30 VDC ¹⁾
	with push-pull (K, I):	10 ... 30VDC 1)
Power consumption	40 mA (5VDC), 60 mA (10VDC), 30 mA (24VDC)	
Standard- Output versions ²⁾	RS 422 (R):	A, B, N, \bar{A} , \bar{B} , \bar{N} , \bar{Alarm}
	RS 422 (T):	A, B, N, \bar{A} , \bar{B} , \bar{N} , Sense
	push-pull (K):	A, B, N, \bar{Alarm}
	push-pull complementary (I):	A, B, N, \bar{A} , \bar{B} , \bar{N} , \bar{Alarm}

¹⁾ Pole protection with supply voltage 10...30 VDC

²⁾ Output description and technical data see section „Output“.

DIMENSIONED DRAWING

Mounting = F:
blind shaft with clamping ring

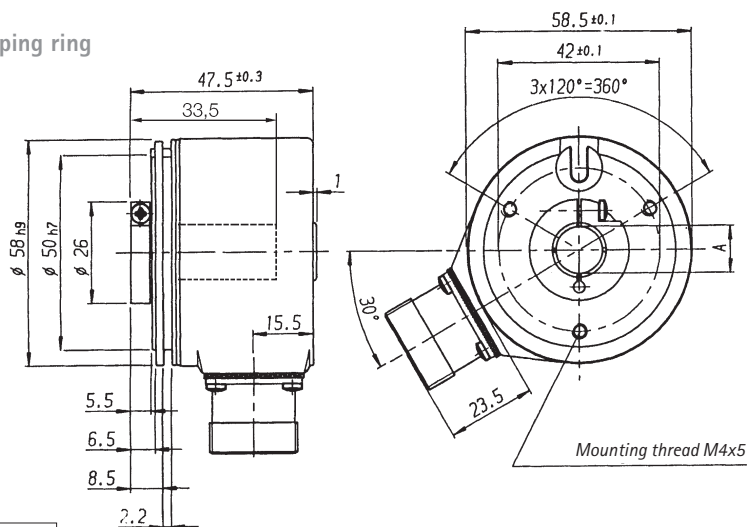

Dim.:	Ø of hollow shaft			Unit
A	10 ^{H7}	12 ^{H7}	14 ^{H7}	mm
A*	10 ^{g8}	12 ^{g8}	14 ^{g8}	mm

A* = Diameter of connection shaft

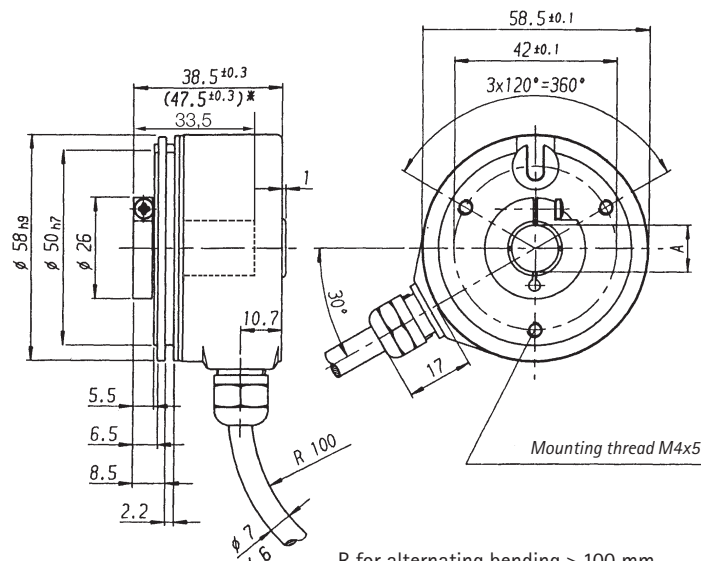

Dimensions in mm

*with Version 10-30 V RS 422

**with mounting F: clamping shaft; not through-going

R for alternating bending > 100 mm

R for permanent bending > 40 mm

Incremental Shaft Encoders Type RI 58-D with Hollow Shaft

DIMENSIONED DRAWING

Mounting = D:
through shaft with clamping ring

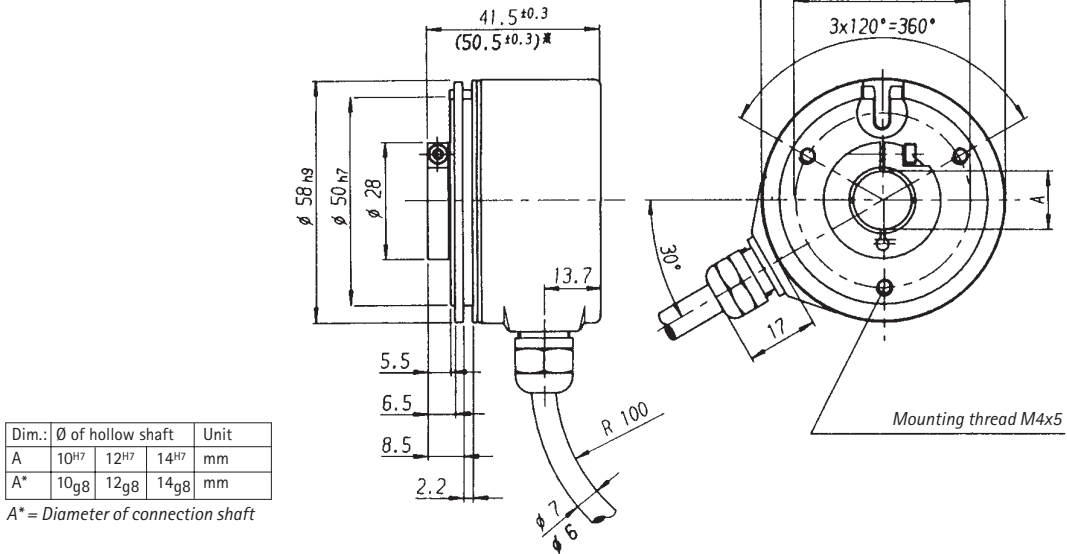

* with Version 10-30 V RS 422

R for alternating bending > 100 mm
R for permanent bending > 40 mm

OPTION:
Clamping ring at rear on request

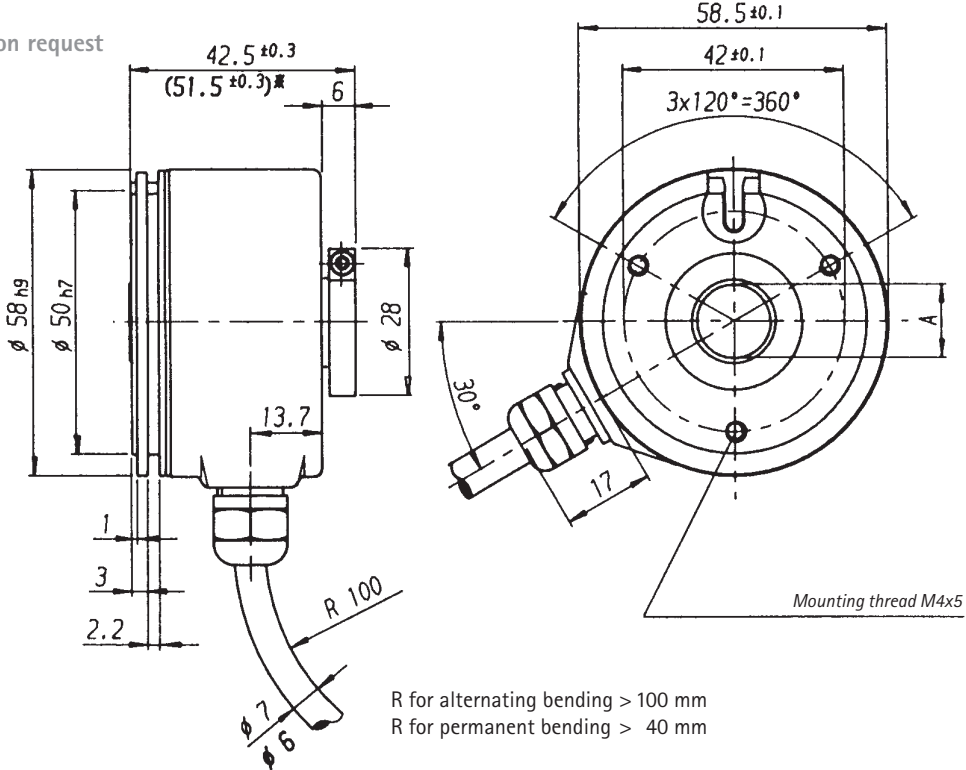

R for alternating bending > 100 mm
R for permanent bending > 40 mm

Incremental Shaft Encoders Type RI 58-D with Hollow Shaft

DIMENSIONED DRAWING

Mounting of version E, blind shaft
(no through shaft)

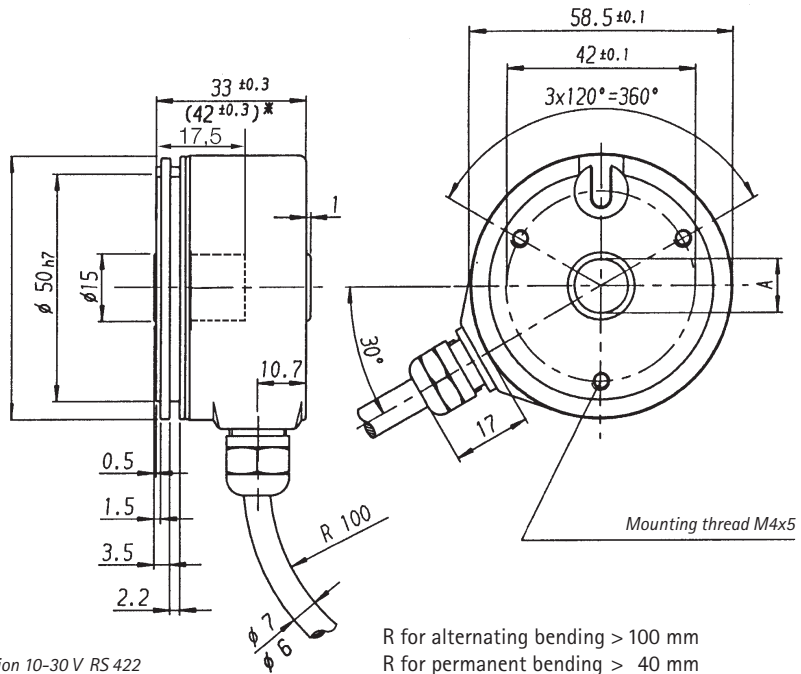
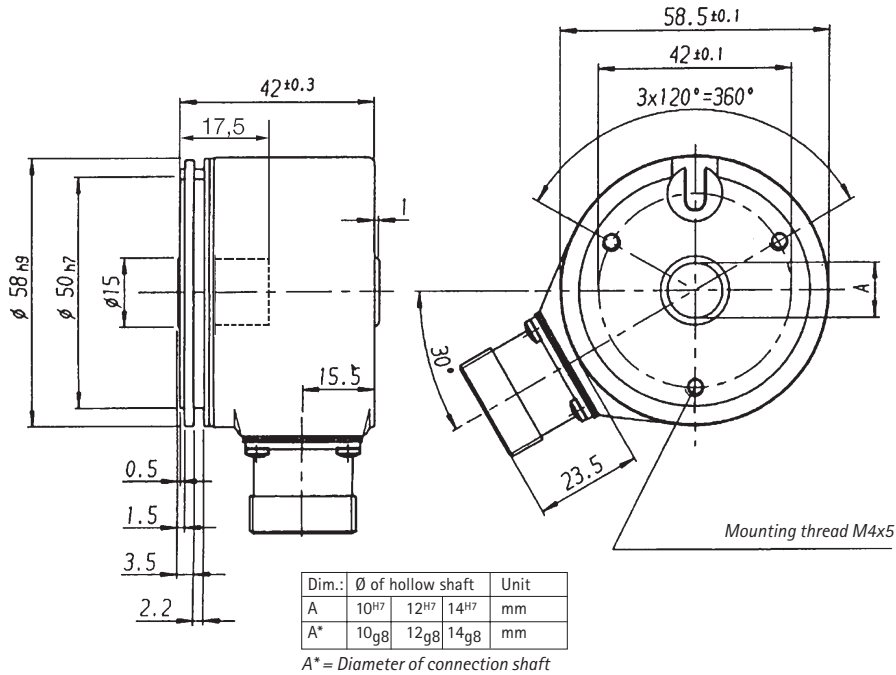

Dimensions in mm

Incremental Shaft Encoders Type RI 58-D with Hollow Shaft

MOUNTING NECESSITIES

In order to be able to compensate an axial and radial misalignment of the shaft, the encoder flange must not be fixed rigidly.

Fix the flanges by means of a stator coupling (e.g. spring plate) as torque support (see "Accessories") or by means of a cylindrical pin:

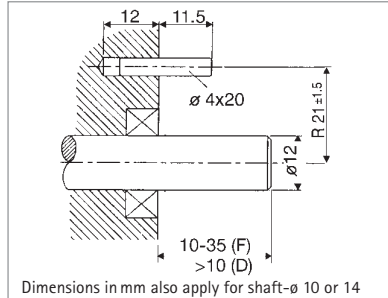

Mounting D, F (Clamping shaft)

Preparation of the machine flange1) (all mounting versions):

In the machine flange a straight pin must be installed (diameter 4x16 resp. 4x20, DIN 6325).

This pin is required as a torque support.

¹⁾ Or as an option: stator coupling as torque support

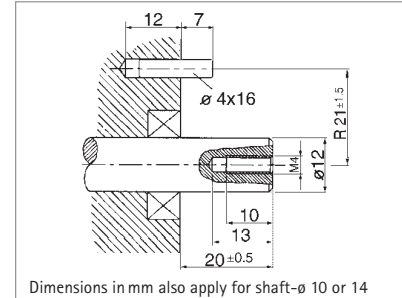

Mounting E (Blind shaft)

Preparation of the drive shaft (only in mounting = E):

The drive shaft must be provided with a threaded bore M 4 x10:

This bore accepts the fastening screw of the shaft encoder.

CONNECTION DIAGRAM CABLE PVC

Cable PVC	RS 422	Output circuit	push-pull (K)	push-pull complementary (I)
Colour	+ Sense (T)	+ Alarm (R)		
white	Channel A	Channel A	Channel A	Channel A
white/brown	Channel \bar{A}	Channel \bar{A}		Channel \bar{A}
green	Channel B	Channel B	Channel B	Channel B
green/brown	Channel \bar{B}	Channel \bar{B}		Channel \bar{B}
yellow	Channel N	Channel N	Channel N	Channel N
yellow/brown	Channel \bar{N}	Channel \bar{N}		Channel \bar{N}
yellow/black	Sense GND	$\bar{A}larm$	$\bar{A}larm$	$\bar{A}larm$
yellow/red	Sense V_{cc}	Sense V_{cc}		Sense V_{cc}
red	5 V DC=	5/10...30 V DC=	10...30 V DC=	10...30 V DC=
black	GND	GND	GND	GND
Cable screen ¹⁾	Cable screen ¹⁾	Cable screen ¹⁾	Cable screen ¹⁾	Cable screen ¹⁾

¹⁾ connected to housing

CONNECTION DIAGRAM CABLE TPE

Cable TPE	RS 422	Output circuit	push-pull (K)	push-pull complementary (I)
Colour	+ Sense (T)	+ Alarm (R)		
brown	Channel A	Channel A	Channel A	Channel A
green	Channel \bar{A}	Channel \bar{A}		Channel \bar{A}
grey	Channel B	Channel B	Channel B	Channel B
pink	Channel \bar{B}	Channel \bar{B}		Channel \bar{B}
red	Channel N	Channel N	Channel N	Channel N
black	Channel \bar{N}	Channel \bar{N}		Channel \bar{N}
violet (white) ²⁾	Sense GND	$\bar{A}larm$	$\bar{A}larm$	$\bar{A}larm$
blue	Sense V_{cc}	Sense V_{cc}		Sense V_{cc}
brown/green	5 V DC=	5/10...30 V DC=	10...30 V DC=	10...30 V DC=
white/green	GND	GND	GND	GND
Cable screen ¹⁾	Cable screen ¹⁾	Cable screen ¹⁾	Cable screen ¹⁾	Cable screen ¹⁾

¹⁾ connected to housing

²⁾ white with Version Sense (T)

Incremental Shaft Encoders Type RI 58-D with Hollow Shaft

CONNECTION DIAGRAM CONNECTOR (CONIN)

Pin	RS 422 + Sense (T)	RS 422 + Alarm (R)	push-pull (K)	push-pull complementary (I)
1	Channel B	Channel B	N.C.	Channel \bar{B}
2	Sense V_{CC}	Sense V_{CC}	N.C.	Sense V_{CC}
3	Channel N	Channel N	Channel N	Channel N
4	Channel \bar{N}	Channel \bar{N}	N.C.	Channel \bar{N}
5	Channel A	Channel A	Channel A	Channel A
6	Channel \bar{A}	Channel \bar{A}	N.C.	Channel \bar{A}
7	N.C.	Alarm	Alarm	Alarm
8	Channel B	Channel B	Channel B	Channel B
9	N.C. ¹⁾	N.C. ¹⁾	N.C. ¹⁾	N.C. ¹⁾
10	GND	GND	GND	GND
11	Sense GND	N.C.	N.C.	N.C.
12	5 V DC=	5/10 ... 30 V DC=	10 ... 30 V DC=	10 ... 30 V DC=

¹⁾ screen with cable version with CONIN-connector

ACCESSORIES

Spring plate as stator coupling: **Ordering code 1 531 162**

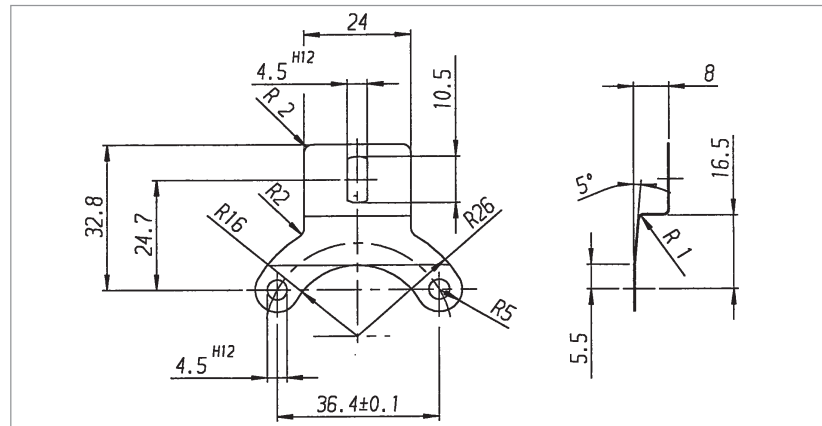

ORDERING DATA

-D hollow shaft	Supply voltage	Mounting	Shaft diameter
TD hollow shaft 100° C	A 5 VDC	synchro flange with	2 10 mm
	E 10 ... 30 VDC	E blind shaft ¹⁾	7 12 mm
		F clamping shaft ¹⁾	9 14 mm ¹⁾
		D clamping shaft ²⁾	

RI 58	/								
--------------	---	--	--	--	--	--	--	--	--

Number of pulses 1 ... 5,000	Output K push-pull T RS 422 + Sense R RS 422 + Alarm I push-pull complementary	Type of connection B PVC-cable radial F TPE-cable radial D CONIN-connector radial, clockwise ³⁾ H CONIN-connector radial, counter ³⁾ clockwise
Protection class 3 IP 642) 4 IP 641)		

¹⁾ Mounting E, F; no through shaft, protection class code 4

²⁾ through shaft, protection class code 3, only cable connection

³⁾ only with mounting E or F (not through going)

Incremental Shaft Encoders Type RI 76 TD with Hollow Shaft



NUMBER OF PULSES

TECHNICAL DATA
mechanical

TECHNICAL DATA
electrical

- Through shaft with up to diameter 42 mm
- Short overall length with an outside diameter of only 76 mm
- Easy installation by means of clamping ring
- Operating temperature up to 100 °C
- Application e.g.:
 - motors
 - printing machines
 - lifts

50 / 100 / 250 / 300 / 500 / 600 / 900 / 1,000 / 1,024 / 1500 / 2,048 / 2,500 / 3,072 / 4096 / 5,000 / 9,000 / 10,000

Other numbers of pulses available on request

Shaft fixation	clamping ring, front or rear
Coupling	stator coupling (spring plate)
Shaft diameter	15...42 mm (Available: 15, 16, 18, 20, 24, 25, 27, 28, 30, 32, 38, 40, 42 mm also 5/8", 1 1/8", 3/4")
Minimum length of mounting shaft	
Front clamping ring	32 mm with Ø 15...30, 35 mm with Ø > 30...42
Rear clamping ring	corresponding to total length of encoder
Max. parallel shaft misalignment	
With flexible stator coupling A (flexible)	±2.0 mm axial, ±0.15 mm radial
With 1 x flexible stator coupling N (torsionally rigid)	±0.5 mm axial, ±0.3 mm radial
With 2 x flexible stator coupling N (torsionally rigid)	±0.3 mm axial, ±0.2 mm radial
Absolute maximum speed	at 70° C and IP 64: 3,600 RPM for Ø 15...25 at 70° C and IP 64: 1,800 RPM for Ø > 25...42 at 70° C and IP 40: 6,000 RPM for Ø 15...42 at 100° C always: 1,800 RPM for Ø 15...42
Torque	3...10 Ncm (depending on version)
Moment of inertia	140...420 gcm ² (depending on version)
Protection class (EN 60529)	Housing IP 50, bearings IP 40
Option:	Housing IP 65, bearings IP 64
Operating temperature	-25 ...+100 °C
Storage temperature	-25...+100 °C
Vibration proof (IEC 68-2-6)	10 g = 100 m/s ² (10 ... 2,000 Hz)
Shock resistance (IEC 68-2-27)	100 g = 1,000 m/s ² (6 ms)
Type of connection	1.5 m cable ¹⁾ radial
Housing	aluminium
Weight	320 - 580 g (depending on version)

¹⁾ Other cable length on request

General design	as per DIN EN 61010, protection class III, contamination level 2, overvoltage class II	
Supply voltage (SELV)	with RS 422 (R, T):	5 VDC ± 10 %
	with push-pull (K, I):	10 ... 30 VDC ¹⁾
Power consumption	60 mA (5VDC), 60 mA (10VDC), 35 mA (24VDC)	
Standard-Output versions ²⁾	RS 422 (R):	A, B, N, \bar{A} , \bar{B} , \bar{N} , \bar{A} Alarm
	RS 422 (T):	A, B, N, \bar{A} , \bar{B} , \bar{N} , Sense
	push-pull (K):	A, B, N, \bar{A} Alarm
	push-pull complementary (I):	A, B, N, \bar{A} , \bar{B} , \bar{N} , \bar{A} Alarm

¹⁾ Pole protection with supply voltage 10 ... 30 VDC

²⁾ Output description and technical data see section „output“.

Incremental Shaft Encoders Type RI 76 TD with Hollow Shaft

DIMENSIONED DRAWING

WITH SPRING PLATE "RIGID"

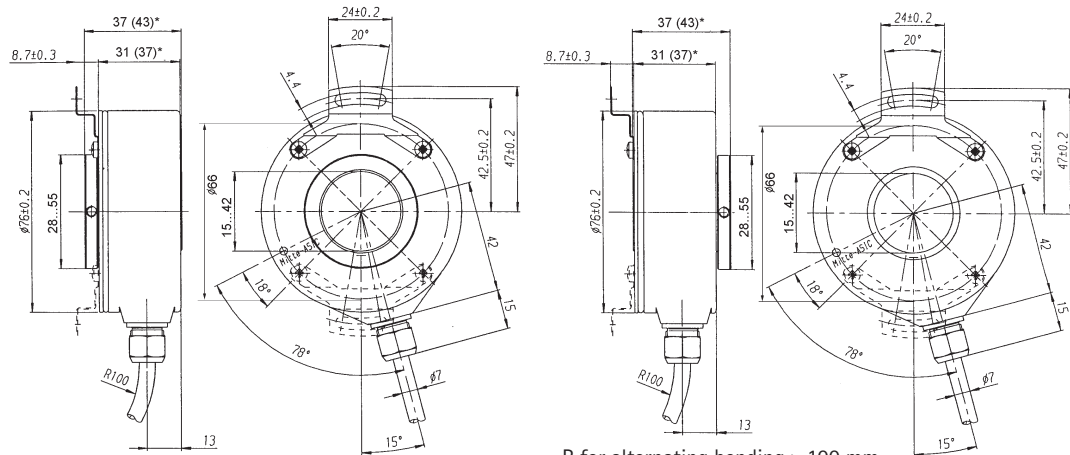

* Values in brackets for shaft diameter > 30
Diameter of connection shaft 15g8...42g8

R for alternating bending > 100 mm
R for permanent bending > 40 mm

WITH SPRING PLATE "FLEXIBLE"

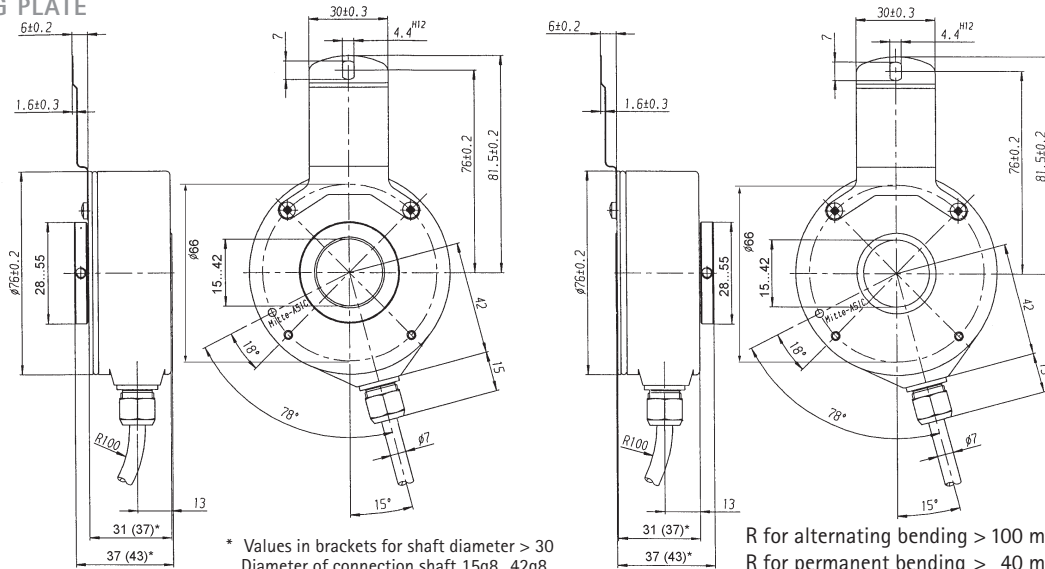

* Values in brackets for shaft diameter > 30
Diameter of connection shaft 15g8...42g8

R for alternating bending > 100 mm
R for permanent bending > 40 mm

SHAFT CONNECTION

Shaft fixing is done through a clamping ring either on the flange or cap side. As a rule, flange side clamping is better for smaller motors as the available shaft stub is correspondingly shorter. On the other hand, cap side clamping is easier when there is sufficient shaft length available.

MOUNTING NECESSITIES

In order to compensate for axial and radial shaft eccentricity as well as any angle offset, the encoder flange may not be rigidly mounted. Please mount the flange with a flexible stator coupling (e.g. spring plate) as torque support. There are two flexible mounting plates:

- A flexible spring plate (A) for higher levels of play and lower requirements for accuracy.
- A rigid spring plate (N) for reduced play and rigid connection with reduced swing angle. This is suitable in the case of higher accuracy and dynamics requirements.

Incremental Shaft Encoders Type RI 76 TD with Hollow Shaft

CONNECTION DIAGRAM CABLE TPE

Colour (TPE)	Output circuit			
	RS 422	RS 422	push-pull (K)	push-pull complementary (I)
	+ Sense (T)	+ Alarm (R)		
brown	Channel A	Channel A	Channel A	Channel A
green	Channel \bar{A}	Channel \bar{A}		Channel \bar{A}
grey	Channel B	Channel B	Channel B	Channel B
pink	Channel \bar{B}	Channel \bar{B}		Channel \bar{B}
red	Channel N	Channel N	Channel N	Channel N
black	Channel \bar{N}	Channel \bar{N}		Channel \bar{N}
violet (white) ²⁾	Sense GND	\bar{A} Alarm	\bar{A} Alarm	\bar{A} Alarm
blue	Sense V _{CC}	Sense V _{CC}		Sense V _{CC}
brown/green	5 VDC=	5/10 ... 30 VDC=	10 ... 30 VDC=	10 ... 30 VDC=
white/green	GND	GND	GND	GND
Screen ¹⁾	Screen ¹⁾	Screen ¹⁾	Screen ¹⁾	Screen ¹⁾

¹⁾ connected to housing

²⁾ white for RS 422 + Sense (T)

ACCESSORIES

Spring plate, flexible	Ordering code 1 533 079
Spring plate, rigid	Ordering code 1 533 078

ORDERING DATA

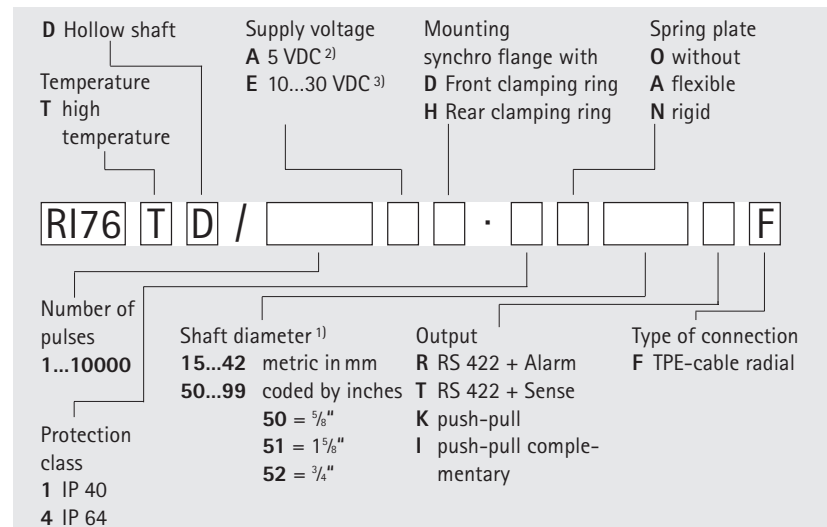

¹⁾ Available with front clamping ring and IP 40: 15, 20, 24, 25, 27, 28, 30, 38, 40, 42, 50 (5/8"), 51 (1 1/8")

Available with front clamping ring and IP 64: 15, 16, 18, 20, 24, 25, 27, 28, 30, 32, 38, 40, 42, 50 (5/8"), 51 (1 1/8"), 52 (3/4")

Available with rear clamping ring and IP 40: 25, 28, 30, 32, 38, 40, 42

Available with rear clamping ring and IP 64: 20, 25, 30, 32, 38, 40, 42

Bold printed: preferred versions

Others: please request delivery time

²⁾ only with output R, T, K

³⁾ only with output R, K, I

Economy Types



- Replacement for type RIS and RI 31
- The economical encoder for small appliances
- High efficiency by means of ball bearing
- Small torque
- Application e.g.
 - laboratory equipment
 - training equipment
 - crimping machines
 - tampon printing machines
 - miniature grinding machines

NUMBER OF PULSES

5 / 10 / 20 / 25 / 30 / 50 / 60 / 100 / 120 / 128 / 200 / 250 / 256 / 288 / 300 / 360 / 400 / 500 / 512 / 600 / 720 / 900 / 1,000 / 1,024 / 1,250 / 1,500
 Other numbers of pulses available on request

TECHNICAL DATA mechanical

Shaft diameter	5 mm / 6 mm
Absolute max. shaft load	radial 30 N (6.5 lbs), axial 15 N (3.3 lbs)
Absolute maximum speed	max. 6,000 RPM
Torque	≤ 0.05 Ncm
Protection class (EN 60529)	Housing IP 50, bearings IP 40
Operating temperature	-10 ... +60 °C
Storage temperature	-25 ... +85 °C
Vibration proof (IEC 68-2-6)	100 m/s ² (10 ... 2,000 Hz)
Shock resistance (IEC 68-2-27)	1,000 m/s ² (6 ms)
Type of connection	1.5 m cable axial/radial ¹⁾
Material	Housing: plastic; Flange: aluminium
Flange	Round flange
Weight	ca. 50 g
Bearing life	2.4 x 10 ⁹ revolutions (typ.) at 35% of full rated shaft load 2.4 x 10 ⁸ revolutions (typ.) at 75% of full rated shaft load 2.4 x 10 ⁷ revolutions (typ.) at 100% of full rated shaft load For example 10,000 h at 4,000 RPM with a 2 lb radial load

¹⁾ Other cable length on request

TECHNICAL DATA electrical

General design	as per DIN VDE 0160, protection class III, contamination level 2, overvoltage class II
Supply voltage (SELV)	with push-pull (D): 5VDC ± 10% with push-pull (K): 5VDC ¹⁾ ± 10% oder 10 ... 30VDC ¹⁾
Power consumption	40 mA (5VDC), 60 mA (10VDC), 30 mA (24VDC)
Standard-Output versions ²⁾	push-pull (K, D): A, B, N, Alarm

¹⁾ Pole protection

²⁾ Output description and technical data see section „Output“.

Economy Types

DIMENSIONED DRAWING

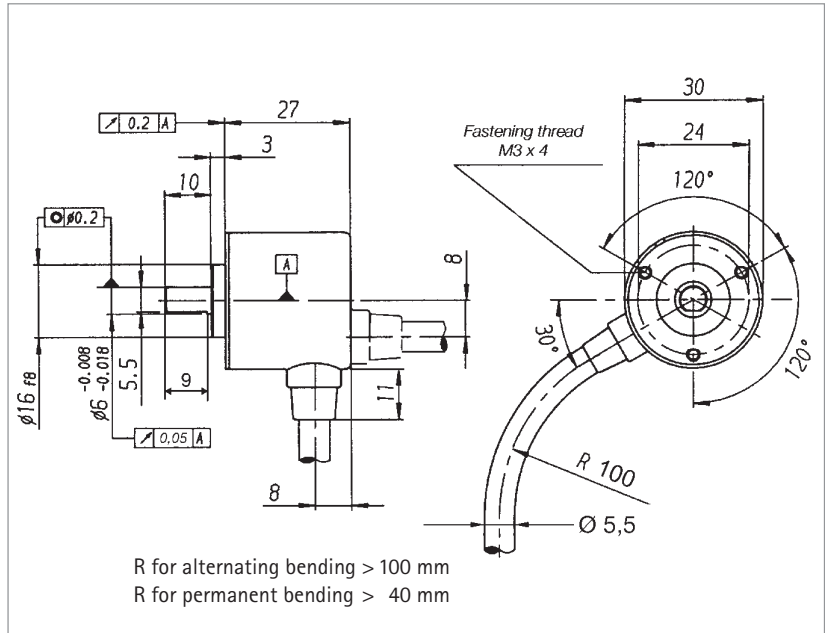

CONNECTION DIAGRAM

Description (push-pull)	Lead ϕ mm ²	Colour
5 VDC/10-30 VDC	0,5	red
Channel A	0,14	white
Channel B	0,14	green
Channel N	0,14	yellow
GND	0,5	black
Alarm	0,14	yellow/black

ORDERING DATA

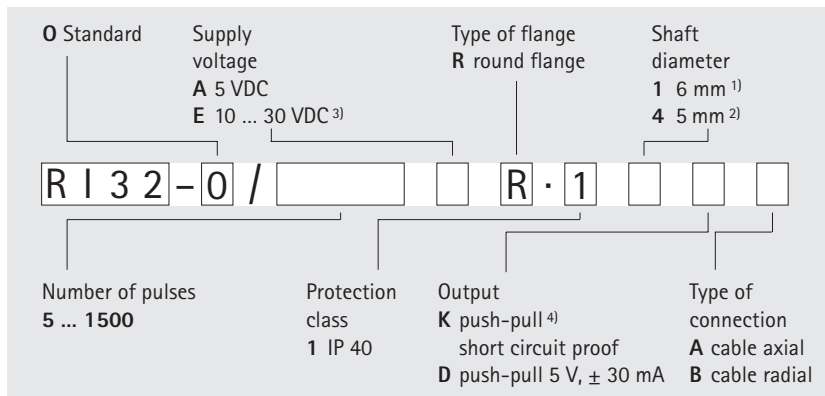

¹⁾ flattened, see dimensioned drawing
²⁾ not flattened
³⁾ only with output K
⁴⁾ \pm 10 mA at 5 V, \pm 30 mA at 10 ... 30 V

Economy Types



- Encoder for universal installation by means of front/back panel mounting
- High efficiency by means of ball bearing
- Small torque
- Application e.g.:
 - FHP motors
 - laboratory equipment
 - labelling machines
 - plotters
 - length measuring machines

NUMBER OF PULSES

5 / 10 / 20 / 25 / 28 / 32 / 50 / 60 / 72 / 100 / 128 / 144 / 200 / 250 / 256 / 288 / 300 / 360 / 400 / 500 / 512 / 600 / 720 / 900 / 1,000 / 1,024
 Other numbers of pulses available on request

TECHNICAL DATA mechanical

Shaft diameter	6 mm
Absolute max. shaft load	radial 30 N (6.5 lbs), axial 15 N (3.3 lbs)
Absolute maximum speed	max. 10,000 RPM
Torque	≤ 0.2 Ncm
Protection class (EN 60529)	Housing IP 50, bearings IP 40
Operating temperature	-10 ... +60 °C
Storage temperature	-25 ... +85 °C
Vibration proof	100 m/s ² (10 ... 2000 Hz)
Shock resistance	1000 m/s ² (6 ms)
Type of connection	1.5 m cable, radial ¹⁾
Housing	glassfibre reinforced plastic
Flange	Q = square flange
Weight	60 g approx.
Bearing life	1 x 10 ¹⁰ revolutions (typ.) at 35% of full rated shaft load 1 x 10 ⁹ revolutions (typ.) at 75% of full rated shaft load 1 x 10 ⁸ revolutions (typ.) at 100% of full rated shaft load For example 30,000 h at 6,000 RPM with a 2 lb radial load

¹⁾ Other cable length on request

TECHNICAL DATA electrical

General design	as per DIN VDE 0160, protection class III, contamination level 2, overvoltage class II
Supply voltage (SELV)	with push-pull (D): 5VDC ± 10% with push-pull (K): 5VDC ¹⁾ ± 10% oder 10 ... 30VDC ¹⁾
Power consumption	40 mA (5VDC), 60 mA (10VDC), 30 mA (24VDC)
Standard-Output versions ²⁾	push-pull (K, D): A, B, N, Alarm

¹⁾ Pole protection

²⁾ Output description and technical data see section "Output"

Economy Types

DIMENSIONED DRAWING

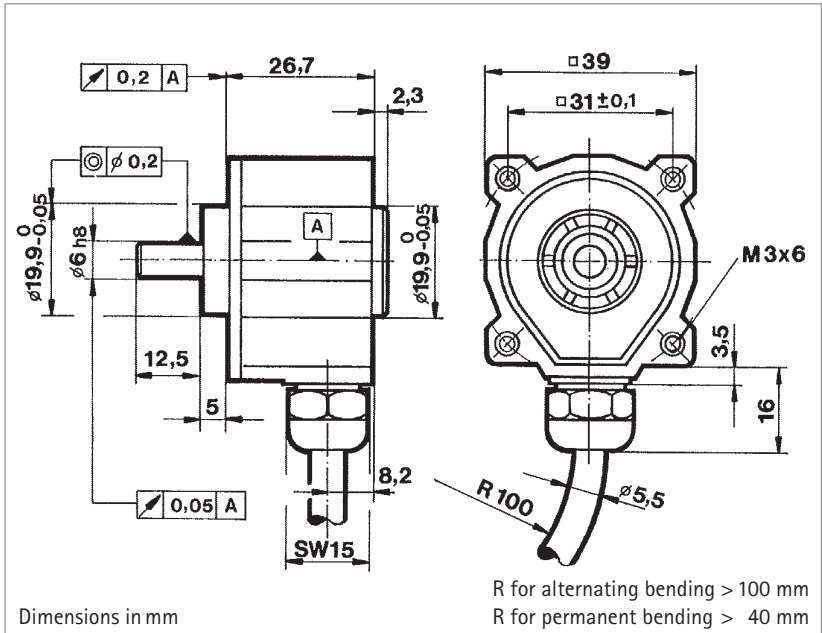

CONNECTION DIAGRAM

Description (push-pull)	Lead Ø mm ²	Colour
5 VDC/10-30 VDC	0,5	red
Channel A	0,14	white
Channel B	0,14	green
Channel N	0,14	yellow
GND	0,5	black
Alarm	0,14	yellow/black

ORDERING DATA

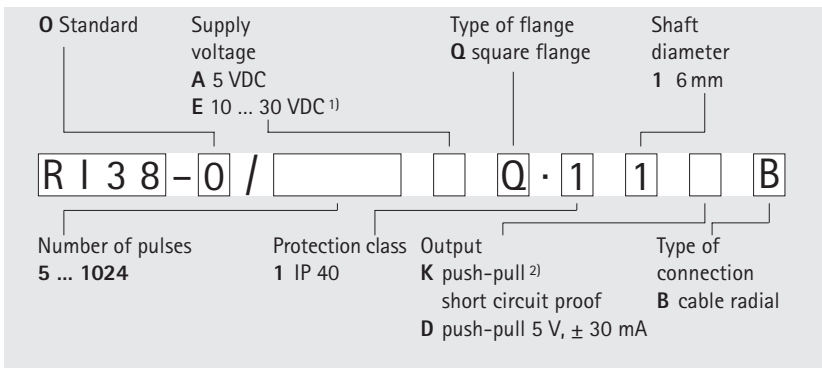

¹⁾ only with output K

²⁾ ± 10 mA at 5 V, ± 30 mA at 10 ... 30 V

Economy Types



- Replacement for type RIM
- Economical miniature encoder
- Up to 14,400 steps with 3,600 pulses
- High mechanical efficiency
- Application e.g.
 - wood working machines
 - FHP motors
 - graphic machines
 - table robots

NUMBER OF PULSES

5 / 10 / 20 / 25 / 28 / 32 / 50 / 60 / 72 / 100 / 128 / 144 / 200 / 250 / 256 / 288 / 300 / 360 / 400 / 500 / 512 / 600 / 720 / 900 / 1,000 / 1,024 / 1,250 / 1,500 / 2,000 / 2,048 / 2,500 / 3,000 / 3,600

Other numbers of pulses available on request

TECHNICAL DATA mechanical

Shaft diameter	6 mm
Absolute max. shaft load	radial 30 N (6.5 lbs), axial 15 N (3.3 lbs)
Absolute maximum speed	max. 10,000 RPM
Torque	≤ 0.2 Ncm
Protection class (EN 60529)	Housing IP 50, bearings IP 40
Operating temperature	-10 ... +70 °C
Storage temperature	-25 ... +85 °C
Vibration proof (IEC 68-2-6)	100 m/s ² (10 ... 2,000 Hz)
Shock resistance (IEC 68-2-27)	1000 m/s ² (6 ms)
Type of connection	1.5 m cable, radial ¹⁾
Housing	Aluminium
Flange	Round flange
Weight	ca. 60 g
Bearing life	1 x 10 ¹⁰ revolutions (typ.) at 35% of full rated shaft load 1 x 10 ⁹ revolutions (typ.) at 75% of full rated shaft load 1 x 10 ⁸ revolutions (typ.) at 100% of full rated shaft load For example 30,000 h at 6,000 RPM with a 2 lb radial load

¹⁾ Other cable length on request

TECHNICAL DATA electrical

General design	as per DIN VDE 0160, protection class III, contamination level 2, overvoltage class II
Supply voltage (SELV)	with push-pull (D): 5VDC ± 10% with push-pull (K): 5VDC ¹⁾ ± 10% oder 10 ... 30VDC ¹⁾
Power consumption	40 mA (5VDC), 60 mA (10VDC), 30 mA (24VDC)
Standard-Output versions ²⁾	push-pull (K, D): A, B, N, Alarm

¹⁾ Pole protection

²⁾ Output description and technical data see section "Output"

Economy Types

DIMENSIONED DRAWING

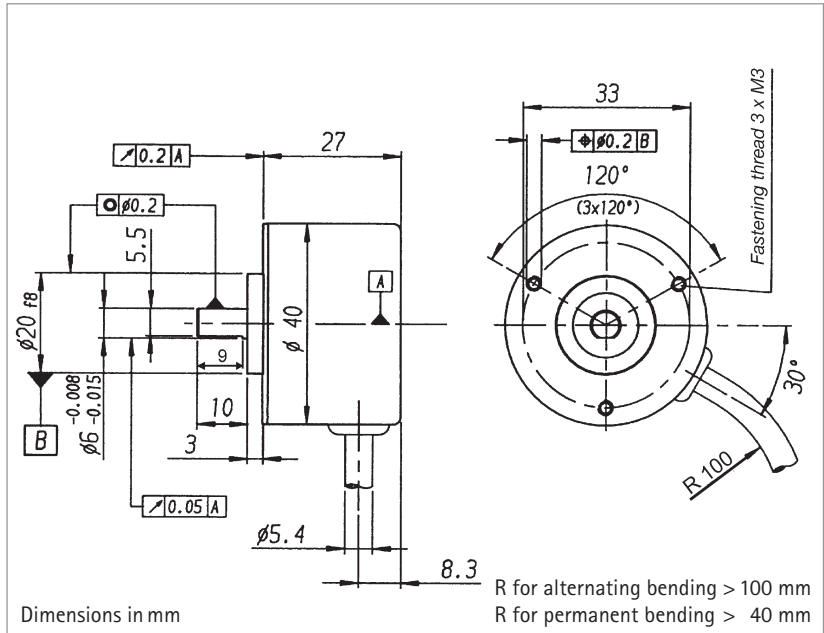

CONNECTION DIAGRAM

Description (push-pull)	Lead Ø mm ²	Colour
5 VDC /10-30 VDC	0,5	red
Channel A	0,14	white
Channel B	0,14	green
Channel N	0,14	yellow
GND	0,5	black
Alarm screen ¹⁾	0,14	yellow/black screen ¹⁾

¹⁾ Not connected to encoder housing

ORDERING DATA

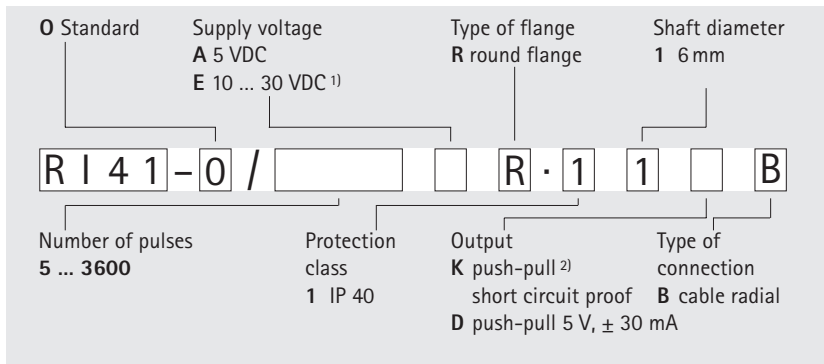

¹⁾ Only with output K

²⁾ ± 10 mA at 5 V, ± 30 mA at 10 ... 30 V

Economy Types



- Economy encoder
- High protection IP 65
- Push-pull or NPN-O.C.
- Applications, e.g.
 - textile machinery

NUMBER OF PULSES

5 / 10 / 20 / 25 / 28 / 32 / 50 / 60 / 72 / 100 / 128 / 144 / 200 / 250 / 256 / 288 / 300 / 360 / 400 / 500 / 512 / 600 / 720 / 900 / 1000 / 1024
 Other numbers of pulses available on request

TECHNICAL DATA mechanical

Shaft diameter	6 mm
Balance tolerances	radial 10 N, axial 5 N
Absolute max. speed	10,000 min ⁻¹
Torque	≤ 1 Ncm
Protection class (EN 60529)	Housing IP 65, bearings IP 64
Operating temperature	0 ... +60 °C
Storage temperature	-25 ... +85 °C
Vibration performance (IEC 68-2-6)	100 m/s ² (10 ... 2000 Hz)
Shock resistance (IEC 68-2-27)	1000 m/s ² (6 ms)
Connection	1.5 m cable axial ¹⁾
Material	plastic, flange: aluminium
Flange	round flange
Weight	approx. 75 g

¹⁾ Other cable length on request

TECHNICAL DATA electrical

General design	as per DIN VDE 0160, protection class III, contamination level 2, overvoltage class II
Supply voltage (SELV)	with push-pull (D): 5 VDC ± 10 % with push-pull (K): 5 VDC ¹⁾ ± 10 % or 10...30 VDC ¹⁾ with push-pull complementary (I): 10...30 VDC ¹⁾ with NPN-O.C. (S): 10...24 VDC ¹⁾
Power consumption	40 mA (5 VDC), 30 mA (24 VDC) with push-pull (K,I) 40 mA (24 VDC), bei NPN-O.C. (S)
Standard-Output versions ²⁾	push-pull ²⁾ / push-pull complementary ²⁾ / NPN-O.C. ³⁾

¹⁾ Pole protection

²⁾ Output description and technical data see section "output"

³⁾ NPN-O.C. with internal pull-up resistor = 10 KΩ, max. pulse frequency = 50 KHz, max. output lead = ± 30 mA, tolerance ≤ ± 30° electrical, delay time ≤ 4μs

Incremental Shaft Encoders Economy Types

Type RI 42

DIMENSIONED DRAWING

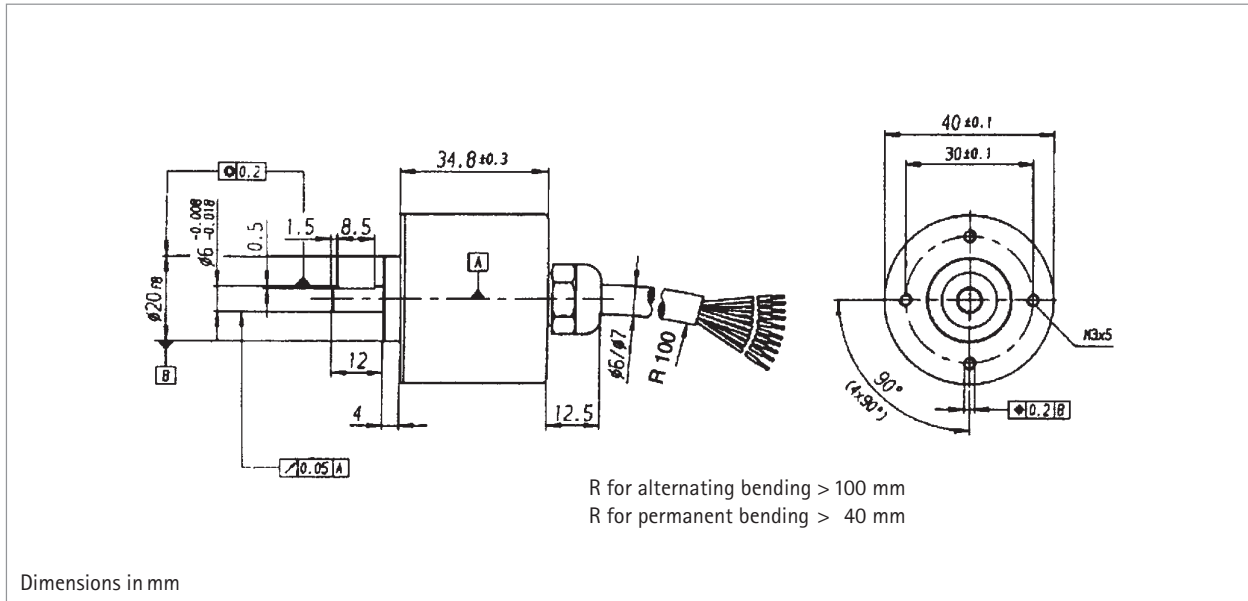

CONNECTION DIAGRAM

Colour (PVC)	Output Circuit	
	push-pull (K, D), Open Collector (S)	push-pull complementary (I)
white	Channel A	Channel A
white/brown		Channel \bar{A}
green	Channel B	Channel B
green/brown		Channel \bar{B}
yellow	Channel N	Channel N
yellow/brown		Channel \bar{N}
yellow/black	Alarm	Alarm
yellow/red		Sense V_{CC}
red	5/10...30/10...24 VDC	10...30 V DC
black	GND	GND

ORDERING DATA

O Standard	Supply voltage	Type of flange	Shaft diameter
	A 5 VDC ¹⁾ E 10 ... 30 VDC ²⁾ C 10 ... 24 VDC ³⁾	R Round flange	1 6 mm

RI42-0 /		R · 4	1		A
Number of pulses	Protection class	Output	Type of connection		
5 ... 1024	4 IP 64	K Push-pull short circuit proof ⁴⁾ D Push-pull 5 V, ± 30 mA S Open Collector NPN I Push-pull complementary	A Cable axial		

¹⁾ only with output K, D
²⁾ only with output K, I
³⁾ only with output S
⁴⁾ ± 10 mA at 5 V, ± 30 mA at 10...30 V