

Rotary Measuring Technology

Incremental shaft encoder

Standard Type series 5802



- Many types in stock
- Sturdy model to industry standard, Ø58 mm housing
- Limited number of versions
- Temperature and ageing compensation
- Short-circuit proof outputs
- Resolution up to 5000 ppr
- High scanning rate
- available as explosion proof zone 2 and 22



Mechanical characteristics:

Speed:	max. 12000 min ⁻¹
Rotor moment of inertia:	approx. 1.8 x 10 ⁻⁶ kgm ²
Starting torque:	< 0.01 Nm
Radial load capacity of shaft*:	80 N
Axial load capacity of shaft*:	40 N
Weight:	approx. 0.4 kg
Protection acc. to EN 60 529:	IP 65
Working temperature:	-20 °C ... +70 °C ¹⁾
Operating temperature:	-20 °C ... +75 °C ¹⁾
Shaft:	stainless steel
Shock resistance acc. to DIN-IEC 68-2-27	1000 m/s ² , 6 ms
Vibration resistance acc. to DIN-IEC 68-2-6:	100 m/s ² , 10...2000 Hz

* View also diagrams on page 25
²⁾ Non-condensing

Pulse rates available at short notice:

10, 20, 25, 30, 50, 60, 100, 120, 125, 127, 150, 180, 200, 216, 240, 250, 254, 256, 300, 314, 360, 375, 400, 500, 512, 600, 625, 720, 745, 750, 762, 800, 900, 927, 1000, 1024, 1250, 1270, 1400, 1500, 1800, 2000, 2048, 2250, 2400, 2500, 3000, 3600, 4000, 4096, 5000

Other pulse rates on request

Electrical characteristics:

Output circuit:	RS 422 (TTL-compatible)	Push-pull	Push-pull
Supply voltage:	5 V (±5 %) or 10 ... 30 V DC	10 ... 30 V DC	5 ... 30 V DC
Power consumption (no load) without inverted signal:	–	typ. 55 mA / max. 125 mA	typ. 55 mA / max. 125 mA
Power consumption (no load) with inverted signals:	typ. 40 mA / max. 90 mA	typ. 80 mA / max. 150 mA	Typ. 80 mA max. 150 mA
Permissible load/channel:	max. ±20 mA	max. ±30 mA	max. ±30 mA
Pulse frequency:	max. 300 kHz	max. 300 kHz	max. 300 kHz
Signal level high:	min. 2.5 V	min. U _B -2.5 V	min. U _B -1.5 V
Signal level low:	max. 0.5 V	max. 2.0 V	max. 2.0 V
Rise time t _r	max. 200 ns	max. 1 µs	max. 1 µs
Fall time t _f	max. 200 ns	max. 1 µs	max. 1 µs
Short circuit proof outputs: ¹⁾	yes ²⁾	yes	yes
Reverse connection protection at U _B :	no	yes	no
Conforms to CE requirements acc. to EN 61000-6-1, EN 61000-6-4 and EN 61000-6-3			

¹⁾ If supply voltage correctly applied

²⁾ Only one channel allowed to be shorted-out:

(If U_B=5 V, short-circuit to channel, 0 V, or +U_B is permitted.)
 (If U_B=5-30 V, short-circuit to channel or 0 V is permitted.)

Rotary Measuring Technology

Incremental shaft encoder



Standard Type series 5802

Terminal assignment

Signal:	0V	0V Sensor ²⁾	+U _B	+U _B Sensor ²⁾	A	Ā	B	B̄	0	0̄	Shield
12 pin plug, Pin:	10	11	12	2	5	6	8	1	3	4	PH ¹⁾
7 pin plug, Pin:	F	-	D	E	A	-	B	-	C	-	G
10 pin plug, Pin:	F	-	D	E	A	G	B	H	C	I	J
Cable colour:	WH	GY PK	BN	RD BU	GN	YE	GY	PK	BU	RD	

1) PH = Shield is attached to connector housing

2) Sensor cables are connected to the supply voltage internally if long feeder cables are involved they can be used to adjust or control the voltage at the encoder

- If sensor cables are not in use, they have to be insulated or 0 V_{Sensor} has to be connected to 0 V and U_BSensor has to be connected to U_B

- Using RS 422 outputs and long cable distances, a wave impedance has to be applied at each cable end.
Insulate unused outputs before initial startup.

Dimensions

Clamping bracket ø 58

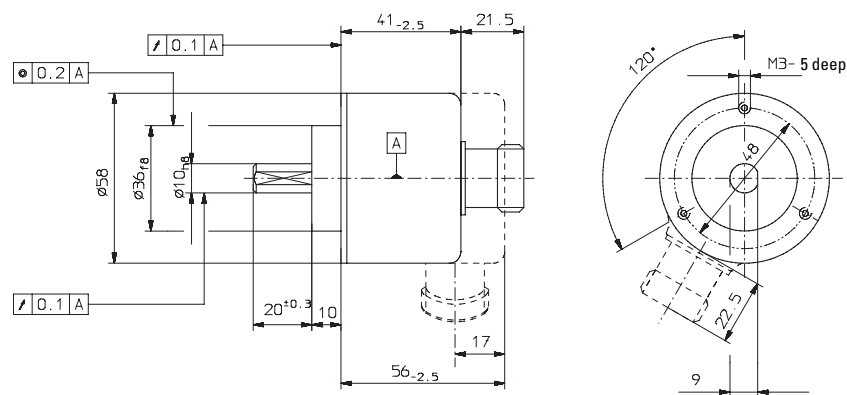

Synchronous bracket ø

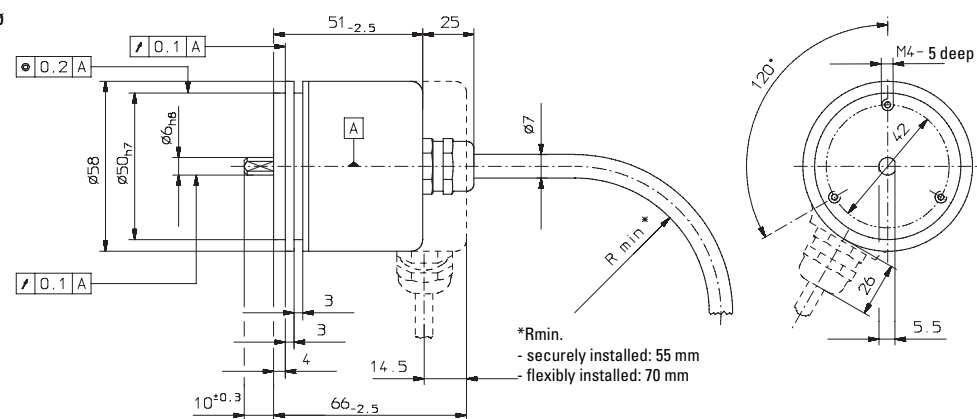

Synchronous bracket ø 63.5 (2.5")

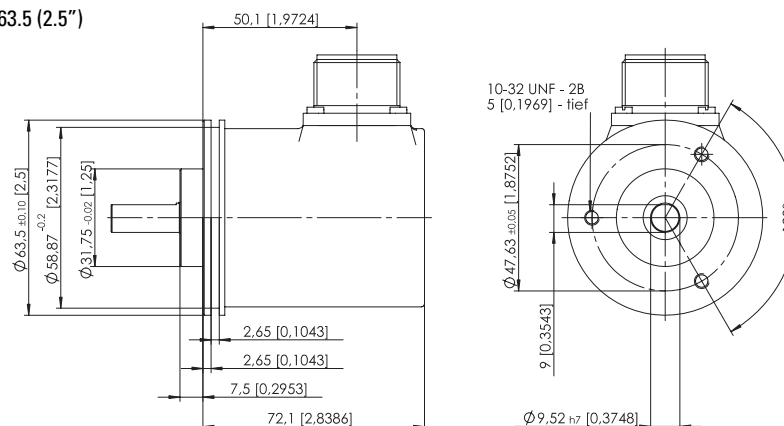

Mounting advice:

The brackets and shafts of the encoder and drive should not both be rigidly coupled together at the same time! We recommend the use of suitable couplings (see Accessories section)

Rotary Measuring Technology

Incremental shaft encoder



Standard Type series 5802

Rectangular bracket □ 63.5 (2.5")

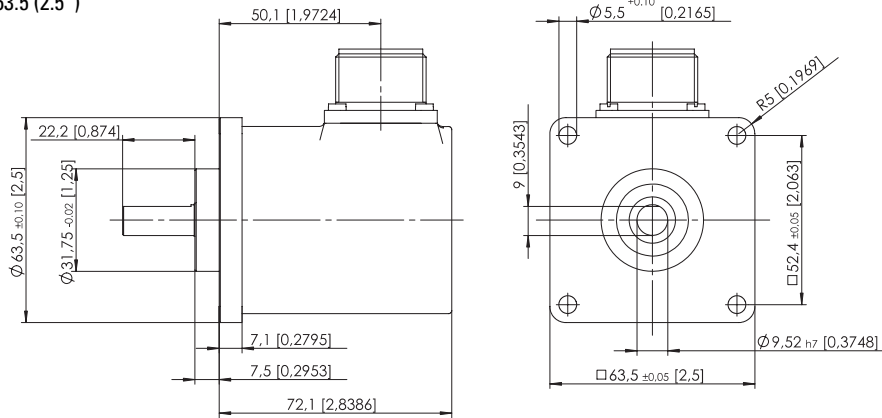

Top view of mating side, male contact base:

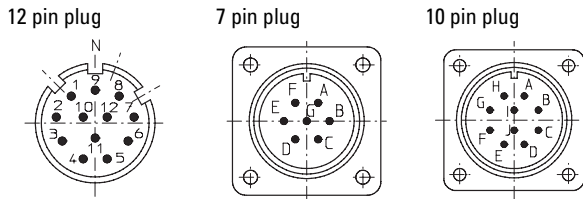

Order code:

8.5802.XXXX.XXXX

Range	Pulse rate (e.g. 250 pulses=> 0250)
Bracket and Shaft 12 = Clamping bracket with Shaft ø 10x20 mm 21 = Synchronous bracket with Shaft ø 6x10 mm MP = Rectangular bracket with Shaft ø 9.52 x 22.2 (3/8" x 7/8") M2 = Rectangular bracket with Shaft ø 10 x 20 PP = Synchronous bracket ø 63.5 with Shaft ø 9.52 x 22.2 (3/8" x 7/8") P2 = Synchronous bracket ø 63.5 with Shaft ø 10 x 20	Type of connection 1 = Cable axial (1 m PVC-Cable) 2 = Cable radial (1 m PVC-Cable) 3 = axial 12 pin plug without mating connector 5 = radial 12pin connector without mating connector W ¹⁾ = 7-pin plug, "MIL"-specified without mating connector, radial Y = 10pin plug, "MIL"-specified without mating connector, radial ¹⁾ Only with output 7+8

Output circuit and supply voltage

4 = RS 422 (with inverted signal) 5 V supply voltage

5 = RS422 (with inverted signal) 10...30 V supply voltage

7 = Push-pull (without inverted signal) 10 ... 30 V supply voltage

8 = Push-pull (without inverted signal) 5 ... 30 V Supply voltage

Preferred types are indicated in bold

Stock types	
8.5802.1275.0200	8.5802.2173.2500
8.5802.1275.0500	8.5802.2173.3600
8.5802.1275.1000	8.5802.2173.5000
8.5802.2143.1000	
8.5802.2143.1024	
8.5802.2143.2500	
8.5802.2143.3600	
8.5802.2143.5000	
8.5802.2173.1000	
8.5802.2173.1024	

Accessories:

Corresponding mating connector to connection type 3 or 5
Art.-no. 8.0000.5012.0000

Corresponding mating connector to connection type W:
Art.-no. 8.0000.5052.0000

Corresponding mating connector to connection type Y:
Art.-no. 8.0000.5062.0000

Further Accessories see Accessories section

Express types

8.5802.12XX.XXXX¹⁾

8.5802.21XX.XXXX¹⁾

8.5802.MPXX.XXXX¹⁾

¹⁾ except connection W and Y

Rotary Measurement Technology
Incremental Encoders