

BOURNS®

Features

- *RoHS compliant
- Absolute encoder / absolute code output
- Digital output
- Sturdy construction
- Bushing mount
- Available with PC board mounting bracket (optional)

EAW - Absolute Contacting Encoder (ACE™)

General Information

Until now, the choice of an absolute encoder meant an expensive, and larger-sized product. Through the use of combinatorial mathematics, the absolute code pattern of the Bourns Absolute Contacting Encoder ACE™ is placed on a single track for a very economical, energy-efficient and compact product. Bourns' ACE™ provides an absolute digital output that will also retain its last position in the event of a power failure.

An intelligent alternative to incremental encoders and potentiometers, the Bourns ACE™ is ideally suited for many industrial, automotive, medical and consumer product applications.

Recommended Control Diagram for ACE-128

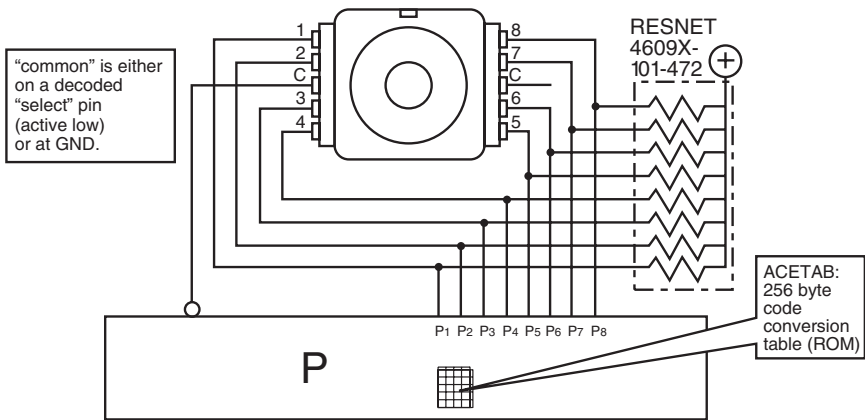

Electrical Characteristics

Output	8-bit code with 128 absolute states
Closed Circuit Resistance	5 ohms maximum
Open Circuit Resistance	100 K ohms minimum
Contact Rating	10 milliamp @ 10 VDC or 0.1 watt maximum
Insulation Resistance (500 VDC)	1,000 megohms minimum
Dielectric Withstanding Voltage (MIL-STD-202 Method 301)	
Sea Level	1,000 VAC minimum
Electrical Travel	Continuous
Contact Bounce (60 RPM)	2.7 milliseconds maximum*
RPM (Operating)	120 maximum

Environmental Characteristics

Operating Temperature Range	-40 °C to +85 °C (-40 °F to +185 °F)
Storage Temperature Range	-40 °C to +85 °C (-40 °F to +185 °F)
Humidity	MIL-STD-202, Method 103B, Condition B
Vibration	15 G
Contact Bounce	0.1 millisecond maximum
Shock	50 G
Contact Bounce	0.1 millisecond maximum
Rotational Life	50,000 shaft revolutions minimum
IP Rating	IP 40

Mechanical Characteristics

Mechanical Angle	360 ° Continuous
Running Torque	0.5 to 1.5 N-cm (0.75 to 2.50 oz-in.)
Mounting Torque	79 N-cm (7 lb.-in.) maximum
Shaft Side Load (Static)	4.5 kg (10 lbs.) minimum
Weight	Approximately 14 gms. (0.50 oz.)
Terminals	Printed circuit board terminals
Soldering Condition	
Manual Soldering	96.5Sn/3.0Ag/0.5Cu solid wire or no-clean rosin cored wire 370 °C (700 °F) max. for 3 seconds
Wave Soldering	96.5Sn/3.0Ag/0.5Cu solder with no-clean flux 260 °C (500 °F) max. for 5 seconds
Wash processes	Not recommended
Marking	Manufacturer's name and trademark, part number, and date code.
Hardware	One lockwasher and one mounting nut are shipped with each encoder, except where noted in the part number.
Packaging	45 pcs./tray

*High probability of missing quadrature codes with maximum bounce.

*RoHS Directive 2002/95/EC Jan 27, 2003 including Annex.
Specifications are subject to change without notice.
Customers should verify actual device performance in their specific applications

EAW - Absolute Contacting Encoder (ACE™)

BOURNS®

Pin Output Code For ACE-128

Bit/Pin correlation: b7 b6 b5 b4 b3 b2 b1 b0 = p8 p7 p6 p5 p4 p3 p2 p1

A binary "1" denotes an "open" switch and a binary "0" denotes a "closed" switch.

Positions 0-127 are seen by a clockwise rotation of the shaft.

Position	p8	p7	p6	p5	p4	p3	p2	p1	Decimal Output
0	0	1	1	1	1	1	1	1	127
1	0	0	1	1	1	1	1	1	63
2	0	0	1	1	1	1	1	0	62
3	0	0	1	1	1	0	1	0	58
4	0	0	1	1	1	0	0	0	56
5	1	0	1	1	1	0	0	0	184
6	1	0	0	1	1	0	0	0	152
7	0	0	0	1	1	0	0	0	24
8	0	0	0	0	1	0	0	0	8
9	0	1	0	0	1	0	0	0	72
10	0	1	0	0	1	0	0	1	73
11	0	1	0	0	1	1	0	1	77
12	0	1	0	0	1	1	1	1	79
13	0	0	0	0	1	1	1	1	15
14	0	0	1	0	1	1	1	1	47
15	1	0	1	0	1	1	1	1	175
16	1	0	1	1	1	1	1	1	191
17	1	0	0	1	1	1	1	1	159
18	0	0	0	1	1	1	1	1	31
19	0	0	0	1	1	1	0	1	29
20	0	0	0	1	1	1	0	0	28
21	0	1	0	1	1	1	0	0	92
22	0	1	0	0	1	1	0	0	76
23	0	0	0	0	1	1	0	0	12
24	0	0	0	0	0	1	0	0	4
25	0	0	1	0	0	1	0	0	36
26	1	0	1	0	0	1	0	0	164
27	1	0	1	0	0	1	1	0	166
28	1	0	1	0	0	1	1	1	167
29	1	0	0	0	0	1	1	1	135
30	1	0	0	1	0	1	1	1	151
31	1	1	0	1	0	1	1	1	215
32	1	1	0	1	1	1	1	1	223
33	1	1	0	0	1	1	1	1	207
34	1	0	0	0	1	1	1	1	143
35	1	0	0	0	1	1	1	0	142
36	0	0	0	0	1	1	1	0	14
37	0	0	1	0	1	1	1	0	46
38	0	0	1	0	0	1	1	0	38
39	0	0	0	0	0	1	1	0	6
40	0	0	0	0	0	0	1	0	2
41	0	0	0	1	0	0	1	0	18
42	0	1	0	1	0	0	1	0	82
43	0	1	0	1	0	0	1	1	83
44	1	1	0	1	0	0	1	1	211
45	1	1	0	0	0	0	1	1	195
46	1	1	0	0	1	0	1	1	203
47	1	1	1	0	1	0	1	1	235
48	1	1	1	0	1	1	1	1	239
49	1	1	1	0	0	1	1	1	231
50	1	1	0	0	0	1	1	1	199
51	0	1	0	0	0	1	1	1	71
52	0	0	0	0	0	1	1	1	7
53	0	0	0	1	0	1	1	1	23
54	0	0	0	1	0	0	1	1	19
55	0	0	0	0	0	0	1	1	3
56	0	0	0	0	0	0	0	1	1
57	0	0	0	0	1	0	0	1	9
58	0	0	1	0	1	0	0	1	41
59	1	0	1	0	1	0	0	1	169
60	1	1	1	0	1	0	0	1	233
61	1	1	1	0	0	0	0	1	225
62	1	1	1	0	0	1	0	1	229
63	1	1	1	1	0	1	0	1	245

Position	p8	p7	p6	p5	p4	p3	p2	p1	Decimal Output
64	1	1	1	1	0	1	1	1	247
65	1	1	1	1	0	0	1	1	243
66	1	1	1	0	0	0	1	1	227
67	1	0	1	0	0	0	1	1	163
68	1	0	0	0	0	0	1	1	131
69	1	0	0	0	1	0	1	1	139
70	1	0	0	0	1	0	0	1	137
71	1	0	0	0	0	0	0	1	129
72	1	0	0	0	0	0	0	0	128
73	1	0	0	0	0	1	0	0	132
74	1	0	0	1	0	1	0	0	148
75	1	1	0	1	0	1	0	0	212
76	1	1	1	1	0	1	0	0	244
77	1	1	1	1	0	0	0	0	240
78	1	1	1	1	0	0	1	0	242
79	1	1	1	1	1	0	1	0	250
80	1	1	1	1	1	0	1	1	251
81	1	1	1	1	1	0	0	1	249
82	1	1	1	1	0	0	0	1	241
83	1	1	0	1	0	0	0	1	209
84	1	1	0	0	0	0	0	1	193
85	1	1	0	0	0	1	0	1	197
86	1	1	0	0	0	1	0	0	196
87	1	1	0	0	0	0	0	0	192
88	0	1	0	0	0	0	0	0	64
89	0	1	0	0	0	0	1	0	66
90	0	1	0	0	1	0	1	0	74
91	0	1	1	0	1	0	1	0	106
92	0	1	1	1	1	0	1	0	122
93	0	1	1	1	1	0	0	0	120
94	0	1	1	1	1	0	0	1	121
95	0	1	1	1	1	1	0	1	125
96	1	1	1	1	1	1	0	1	253
97	1	1	1	1	1	1	0	0	252
98	1	1	1	1	1	0	0	0	248
99	1	1	1	0	1	0	0	0	232
100	1	1	1	0	0	0	0	0	224
101	1	1	1	0	0	0	1	0	226
102	0	1	1	0	0	0	1	0	98
103	0	1	1	0	0	0	0	0	96
104	0	0	1	0	0	0	0	0	32
105	0	0	1	0	0	0	0	1	33
106	0	0	1	0	0	1	0	1	37
107	0	0	1	1	0	1	0	1	53
108	0	0	1	1	1	1	0	1	61
109	0	0	1	1	1	1	0	0	60
110	1	0	1	1	1	1	0	0	188
111	1	0	1	1	1	1	1	0	190
112	1	1	1	1	1	1	1	0	254
113	0	1	1	1	1	1	1	0	126
114	0	1	1	1	1	1	0	0	124
115	0	1	1	1	0	1	0	0	116
116	0	1	1	1	0	0	0	0	112
117	0	1	1	1	0	0	0	1	113
118	0	0	1	1	0	0	0	1	49
119	0	0	1	1	0	0	0	0	48
120	0	0	0	1	0	0	0	0	16
121	1	0	0	1	0	0	0	0	144
122	1	0	0	1	0	0	1	0	146
123	1	0	0	1	1	0	1	0	154
124	1	0	0	1	1	1	1	0	158
125	0	0	0	1	1	1	1	0	30
126	0	1	0	1	1	1	1	0	94
127	0	1	0	1	1	1	1	1	95

Specifications are subject to change without notice.

Customers should verify actual device performance in their specific applications

EAW - Absolute Contacting Encoder (ACE™)

BOURNS®

Dimensional Drawings

Bushing Mounted: Housing A with Rear Facing Terminals

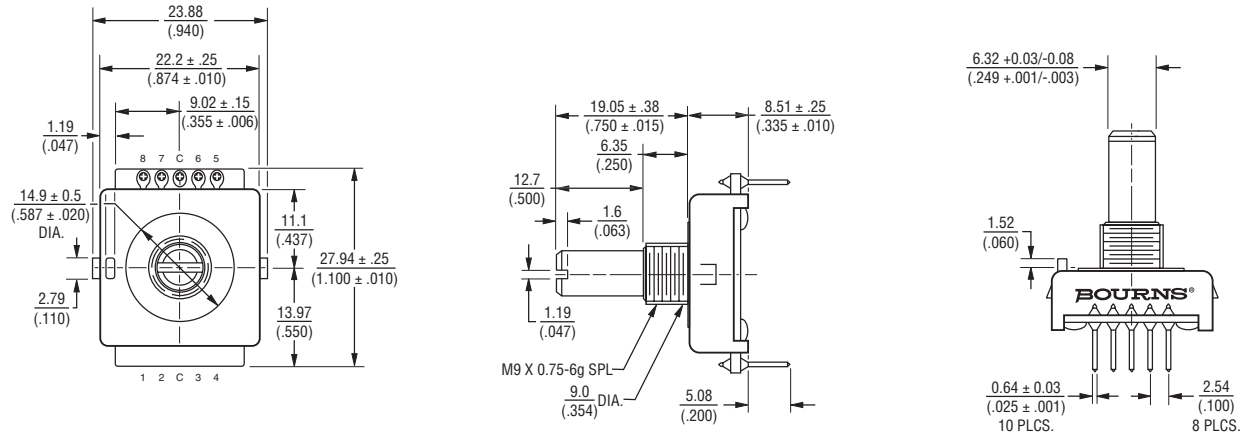

Bushing Mounted: Housing A with Forward Facing Terminals

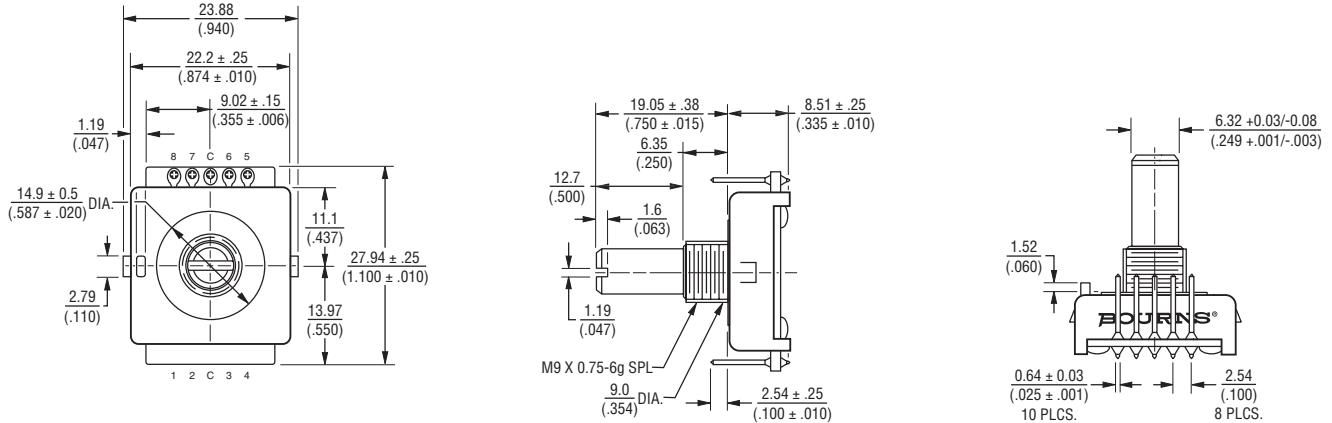

PCB Bracket Mounted: Housing B

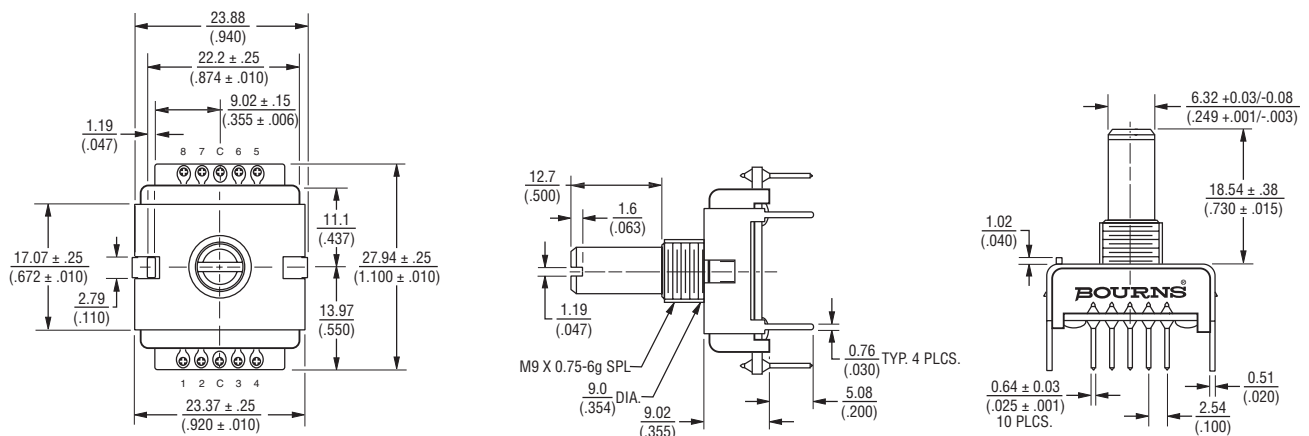

Specifications are subject to change without notice.
Customers should verify actual device performance in their specific applications

EAW - Absolute Contacting Encoder (ACE™)

BOURNS®

Dimensional Drawings

Shaft Style B

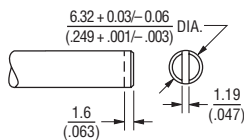

Shaft Style C

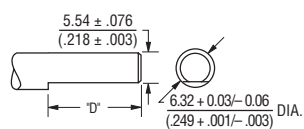

"D" DIMENSION EXTENDS FROM SHAFT END TO BUSHING FACE
 "D" = (SHAFT LENGTH, FMS) - (BUSHING LENGTH)

Shaft Style R

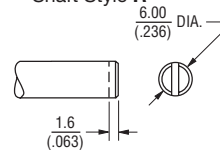

Bushing Mounted: Housing A with Rear Facing Terminals

Panel Hole Dimensions

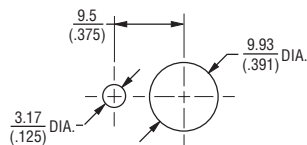

PCB Board Hole Pattern w/PCB Bracket

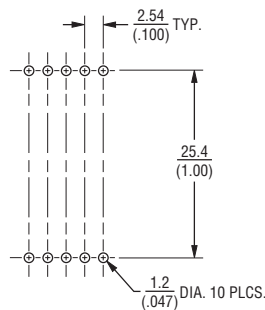

Bushing Mounted: Housing A with Forward Facing Terminals

PCB Board Hole Pattern w/PCB Bracket

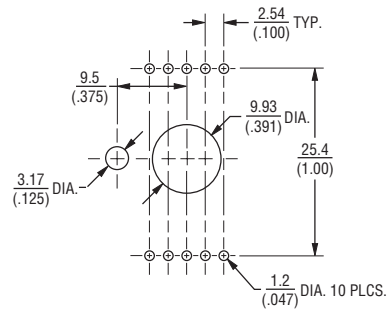

PCB Bracket Mounted: Housing B

Panel Hole Dimensions

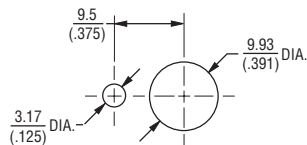

PCB Board Hole Pattern w/PCB Bracket

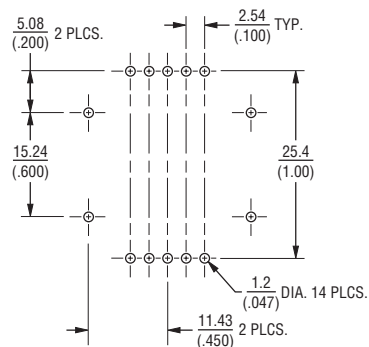

TOLERANCES EXCEPT WHERE NOTED:

.XX = ± .51 (.02) .XXX = ± .127 (.005)

DIMENSIONS: $\frac{\text{MM}}{\text{(IN)}}$

Specifications are subject to change without notice.
 Customers should verify actual device performance in their specific applications

EAW - Absolute Contacting Encoder (ACE™)

BOURNS®

How to Order

PART NUMBERING SYSTEM

E A W 0 J - B 2 4 - A E 0 1 2 8 L

Code	Rotational Life
A	50,000 Revolutions

BUSHING CONFIGURATION	
Code	Description
W	9 mm x 1/4 " Length. Threaded M9x0.75
L	9 mm x 3/8 " Length. Threaded M9x0.75 (Use B shaft only.)

DETENT CONFIGURATION	
Code	Description
0	Non-Detented

ANTI-ROTATION LUG POSITION	
Code	Description
J	9:00 Position
D	None

SHAFT STYLE (See Outline Drawing for Details)	
Code	Description
B	Plain with Inserted Slot (1/4 " Dia.)
C	Single Flatted (1/4 " Dia.)
R	Plain with Inserted Slot (6 mm Dia.)

RoHS IDENTIFIER	
Code	Description
L	Compliant

PERFORMANCE CODE		
Code	Detents	States/Rev.
E0128	0	128

HOUSING TERMINAL CONFIGURATION (X indicates "Equipped With")					
	Code				
Features	A	B	C	H	K
Rear Mount Terminals	X	X	X		
Forward Facing Terminals				X	X
PCB Bracket		X	X		
Hardware Included	X		X	X	

SHAFT LENGTH (FMS)		
Code	Description	Available Shaft Styles
24	3/4 " (19.05 mm) Length	B, C
Metric		
19	19 mm Length	R

The sample part number demonstrates the identification code for Bourns contacting encoders. The part number shown is a commonly used model, typically available from stock.

*Consult factory concerning special inquiries.

REV. 02//25/11

Specifications are subject to change without notice. Customers should verify actual device performance in their specific applications