



M8 Field-Attachable Connectors

Allows easy field conversion to threaded connection quick-disconnect
 Solder connections for reliability in vibration applications
 Male and female in both straight and 90° versions

NEW	3P	4P
FEMALE FACE VIEW		
MALE FACE VIEW		
VOLTAGE	60V AC / 75V DC	60V AC / 75V DC
CURRENT	4A	4A

FEMALE	FIG	FIELD-ATTACHABLE CONNECTORS WITH 3.5-5.0mm (.137-.196"OD) CABLE FITTING	
STRAIGHT	1	N03FA03124	N04FA03124
90°	2	N03FA04124	N04FA04124
MATING RECEPTACLE*		4R3P06A27C300	4R4P06A27C300
MALE	FIG	FIELD-ATTACHABLE CONNECTORS WITH 3.5-5.0mm (.137-.196"OD) CABLE FITTING	
STRAIGHT	3	N03MA03124	N04MA03124
90°	4	N03MA04124	N04MA04124
MATING RECEPTACLE*		4R3P00A27C300	4R4P00A27C300

*See Page 176 for additional Mating Receptacles

Specifications



MECHANICAL
 CONNECTOR FACE: PA
 BODY: PA
 COUPLING NUT: NICKEL-PLATED BRASS
 TERMINATION: SOLDER LUGS; ACCEPTS CONDUCTOR TO #20 AWG

ELECTRICAL
 VOLTAGE RATING: 60V AC/ 75V DC
 AMPERAGE: 4A

ENVIRONMENTAL
 PROTECTION: IP 67
 AMBIENT OPERATING TEMP: 32° TO 185° F (0° TO 85° C)

CONNECTOR DIMENSIONS

FEMALE STRAIGHT

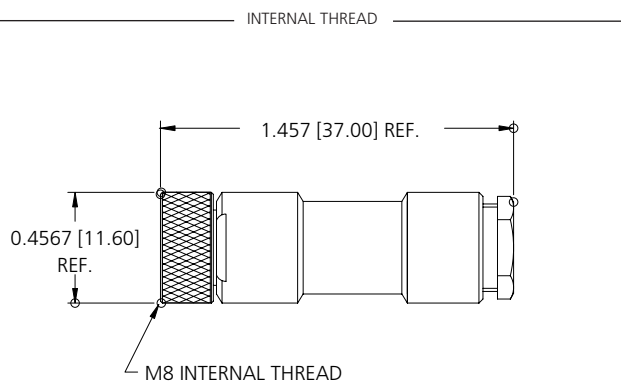

FIG 1

MALE STRAIGHT

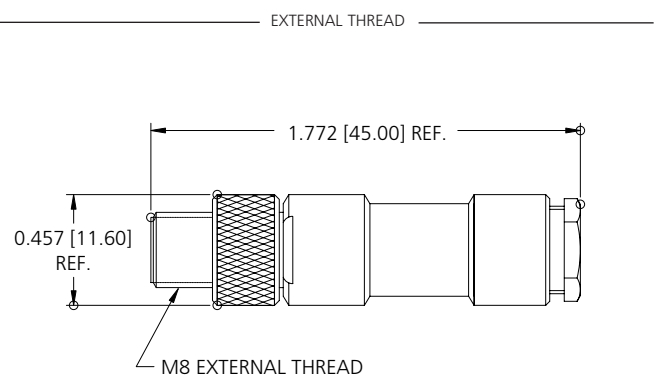

FIG 3

FEMALE 90°

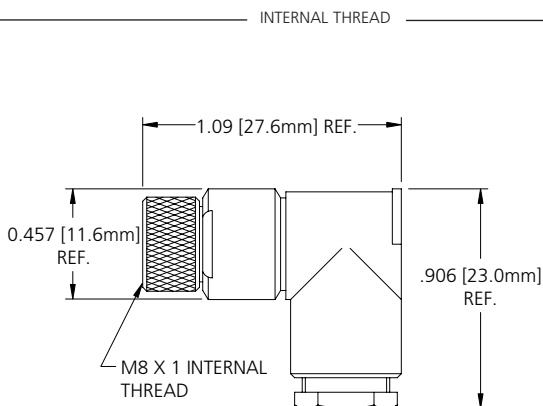

FIG 2

MALE 90°

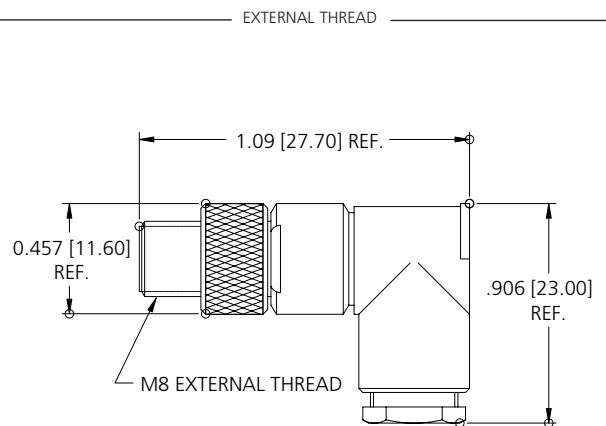

FIG 4