

REFERENCE DRAWING

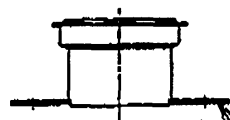

3/16" Quick connect

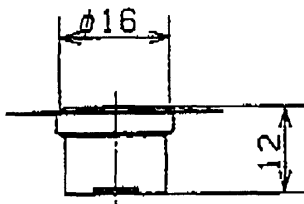
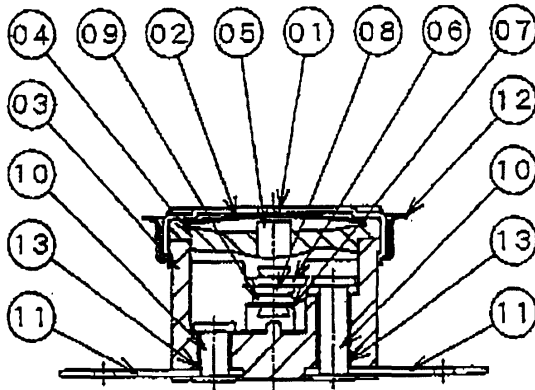

13	Sleeve	Copper
12	Bracket	Stainless steel
11	Terminal	Copper alloy
10	Rivet	Copper
09	Contact	Silver-Nickel alloy
08	Contact	Silver-Nickel alloy
07	Movable arm	Copper alloy
06	Stationary arm	Copper alloy
05	Pin	Ceramic
04	Retainer	Polyethylene sulfide
03	Case	Polyethylene sulfide
02	Bimetal	
01	Cap	Aluminum
No.	Name	Material

Check	Drawing	Indication
		Tolerance Project
		±0.5 3rd
		NIPPON

5	
	ification
	No.

1023



Thermostat Part Number Key/Variation Chart

Our Designation of Type-Code



I	N	AC 120V/AC 240V	15A/10A	: Standard Contact Point								
	S	AC 120V/AC 250V	6A/3A	: For Short Body								
	X	AC 120V/DC 30V	10M-1A	: Cross-Bar Contact Point								
	P	AC 120V/DC 6-30V	10M-100mA	: Cross-Bar Contact Point								
II	1	Open on rise (operation type A)										
	3	Close on rise (operation type B)										
	4	Open on rise: one time operation										
III	0, 1, 4, T, W	Aluminum	No. 0	No. 1,2,3	No. 4,5	No. 6	No. 7	No. A	No. P	No. S	No. T,U,V	No. W
	2, 7, S, U	Copper Alloy										
	3, 5, 6, A, P, V	Stainless Steel										
	0, 1, 2, 3, A, P, W	Fits w/Bracket #...										
	0	Open Cap										
	T, U, V	Close On Rise (Operation Type B)										
	S	Screw Threads (6-32, 8-32UNC)										
7, P	Tube Mounting											
IV V	No. 01 Solder		No. 02 Solder		No. 05 .187 Quick Connect		No. 06/10 .187 Quick Connect		No. 07 Strap			
	No. 03 Weld		No. 11 Strap		No. 12 Crimp		No. 14 .187 Quick Connect		No. 27 Tube			
	No. 28 Strap		No. 36 .187 Quick Connect		No. 43 250 Quick Connect		No. 44 250 Quick Connect					
VI	0	No Bracket										
	B, E, H	Fixed Bracket										
1, 2, 3, 4, A	Loose Bracket											
E, A (With Spring)	Tube Mounting											
		No. A	No. B (Fits with Cap A)	No. E (Fits with Cap P)	No. H (Fits with Cap W)							

MICROTHERM LIMITED

Merrow Business Centre Merrow Lane Guildford Surrey GU4 7WA
 Telephone: +44 (0)1483 450100 Facsimile: +44 (0)1483 451816
 Email: office@microtherm.co.uk Web: www.microtherm.co.uk