

Encoder HEDL 5540, 500 CPT, 3 Channels, with Line Driver RS 422

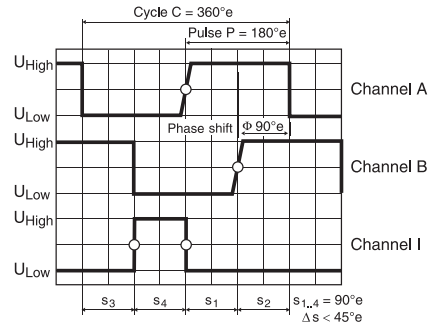
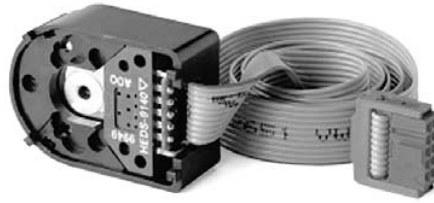
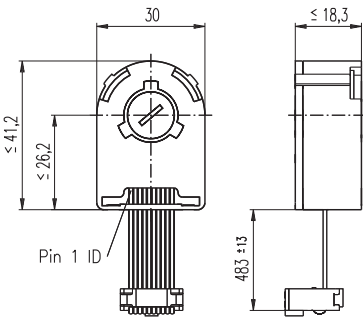

- Stock program
- Standard program
- Special program (on request)

Order Number

110512	110514	110516	110518
--------	--------	--------	--------

Type	110512	110514	110516	110518
Counts per turn	500	500	500	500
Number of channels	3	3	3	3
Max. operating frequency (kHz)	100	100	100	100
Max. speed (rpm)	12000	12000	12000	12000
Shaft diameter (mm)	3	4	6	8



maxon Modular System

+ Motor	Page	+ Gearhead	Page	+ Brake	Page	Overall length [mm] / ● see Gearhead
RE 50, 150 W	83					128.7
RE 50, 150 W	83	GP 52, 4 - 30 Nm	243			●
RE 50, 150 W	83	GP 52, 8 - 50 Nm	245			●
RE 65, 250 W	84					157.3
RE 65, 250 W	84	GP 81, 20 - 120 Nm	246			●
EC 32, 80 W*	156					78.4
EC 32, 80 W*	156	GP 32, 0.75 - 4.5 Nm	232			●
EC 32, 80 W*	156	GP 32, 0.75 - 6.0 Nm	234/236			●
EC 32, 80 W*	156	GP 32 S	251-253			●
EC 40, 120 W*	157					88.4
EC 40, 120 W*	157	GP 42, 3.0 - 15 Nm	240			●
EC 40, 120 W*	157	GP 52, 4.0 - 30 Nm	243			●
EC-max 30, 40 W	170					62.6
EC-max 30, 40 W	170	GP 32, 1 - 6 Nm	236			●
EC-max 30, 40 W	170			AB 20	314	101.7
EC-max 30, 40 W	170	GP 32, 1 - 6 Nm	236	AB 20	314	●
EC-max 30, 40 W	170	GP 32 S				●
EC-max 30, 40 W	170	GP 32, 4.0 - 8.0 Nm	237			●
EC-max 30, 60 W	171					84.6
EC-max 30, 60 W	171	GP 32, 4.0 - 8.0 Nm	237			●
EC-max 30, 60 W	171	GP 42, 3 - 15 Nm	241			●
EC-max 30, 60 W	171			AB 20	314	123.7
EC-max 30, 60 W	171	GP 42, 3 - 15 Nm	241	AB 20	314	●
EC-max 40, 70 W	172					81.4
EC-max 40, 70 W	172	GP 42, 3 - 15 Nm	241			●
EC-max 40, 70 W	172			AB 28	315	121.4
EC-max 40, 70 W	172	GP 42, 3 - 15 Nm	241	AB 28	315	●
EC-max 40, 120 W	173					111.4
EC-max 40, 120 W	173	GP 52, 4 - 30 Nm	244			●
EC-max 40, 120 W	173			AB 28	315	151.4
EC-max 40, 120 W	173	GP 52, 4 - 30 Nm	244	AB 28	315	●

* Pin Allocation siehe Page 270

Technical Data

Supply voltage	5 V ± 10 %
Output signal driver used:	EIA Standard RS 422 DS26LS31
Phase shift Φ	90°e ± 45°e
Signal rise time (typically, at $C_L = 25$ pF, $R_L = 2.7$ k Ω , 25°C)	180 ns
Signal fall time (typically, at $C_L = 25$ pF, $R_L = 2.7$ k Ω , 25°C)	40 ns
Index pulse width	90°e
Operating temperature range	0 ... +70°C
Operating temperature range optional	-40 ... +100°C
Moment of inertia of code wheel	≤ 0.6 gcm ²
Max. angular acceleration	250 000 rad s ⁻²
Output current per channel	min. -20 mA, max. 20 mA
Option	1000 counts per turn, 2 channels

The index signal I is synchronised with channel A or B.

Pin Allocation for motor RE 75

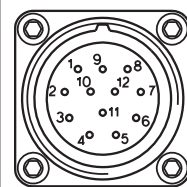

Flanged connector
Type SOURIAU 8GM-QL2-12P
 1 V_{cc}
 2 N.C. (do not connect)
 3 GND
 4 N.C. (do not connect)
 5 Channel I (Index)
 6 Channel A
 7 Channel B
 8 Channel B
 9 Channel A
 10 Channel A
 11 N.C. (do not connect)
 12 N.C. (do not connect)
 recommended cable plug Type SOURIAU 8GM-DM2-12S (metal, straight exit:
 maxon Art. No. 2675.538) or 8G-V2-12S (plastic, 90° angle: maxon Art. No. 2675.539)

Connection example

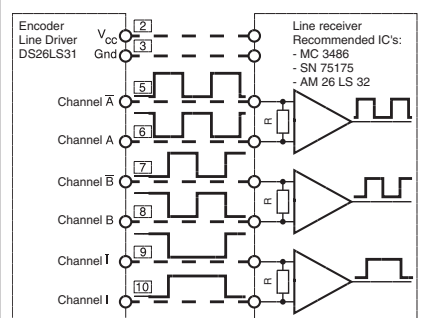

Terminal resistance R = typical 100 Ω