

### Ultra-small-sized Tactile Switch with High Contact Reliability:

1.2 × 3 × 2.5 mm (H × W × D)

- Industry's smallest switch\* allows high-density mounting on PCBs for mobile equipment.  
\*As of October 2006 (according to OMRON survey).
- Dust-proof construction provides high reliability in dusty environments.
- Surface mounted: Ideal for high-density mounting.
- Models with ground terminals are available for protection against static electricity.

RoHS Compliant (See page 3 for details.)

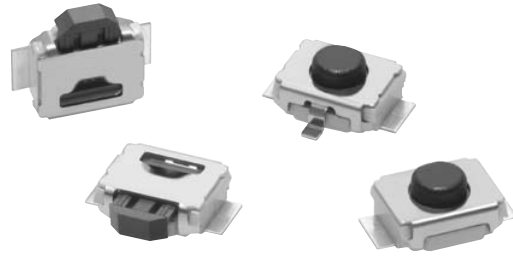

**NEW**

## Ordering Information

Operation type	Order unit	Packaging Ground terminal	Embossed taping	
			Without ground terminal	With ground terminal
Top-actuated	3,500 pieces	Without boss	B3U-1000P	B3U-1100P
		With boss	B3U-1000P-B	B3U-1100P-B
Side-actuated	4,000 pieces	Without boss	B3U-3000P	B3U-3100P
		With boss	B3U-3000P-B	B3U-3100P-B

**Note:** Orders must be made in multiples of the order unit specified above.

## Specifications

### ■ Ratings/Characteristics

Item	Operation type	Top-actuated (B3U-1000 Series)	Side-actuated (B3U-3000 Series)
Switching capacity		1 to 50 mA, 5 to 12 VDC (resistive load)	
Ambient operating temperature		-25 to 70°C, 60% humidity (with no icing or condensation)	
Ambient humidity		35% to 85% (at 5 to 35°C)	
Contact configuration		SPST-NO	
Contact resistance		100 mΩ max. (initial value) (rated: 1 mA, 5 VDC)	
Insulation resistance		100 MΩ min. (at 100 VDC)	
Dielectric strength		250 VAC, 50/60 Hz for 1 min	
Bounce time		5 ms max.	
Vibration resistance		10 to 55 Hz, 1.5 mm double amplitude	
Shock resistance		1,000 m/s <sup>2</sup> max.	
Life expectancy		200,000 operations min.	100,000 operations min.
Maximum operating force		30 N max.	
Weight		Approx. 0.022 g	

## Operating Characteristics

Item	Operation type	Top-actuated (B3U-1000 Series)	Side-actuated (B3U-3000 Series)
Operating force (OF)		1.50 ± 0.49 N	1.59 ± 0.49 N
Releasing force (RF)		0.2 N min.	
Pretravel (PT)		0.15 <sup>+0.2</sup> <sub>-0.1</sub> mm	0.2 <sup>+0.2</sup> <sub>-0.1</sub> mm

## Dimensions

**Note:** All dimensions are in millimeters unless otherwise indicated. Unless otherwise specified, a tolerance of ±0.2 mm applies to all dimensions.

### ■ Top-actuated Models

#### Without Ground Terminal, without Boss B3U-1000P

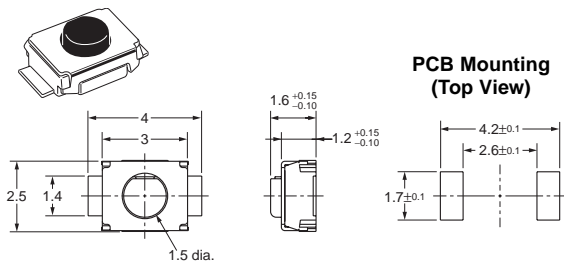

#### With Ground Terminal, without Boss B3U-1100P

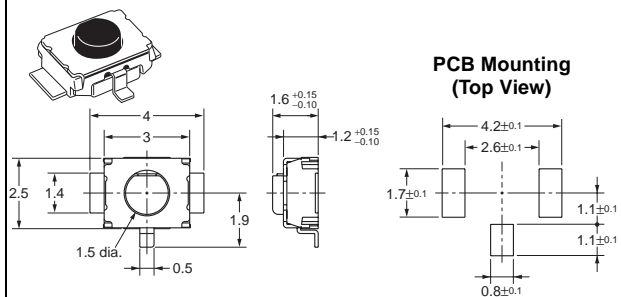

**Without Ground Terminal, with Boss**

**B3U-1000P-B**

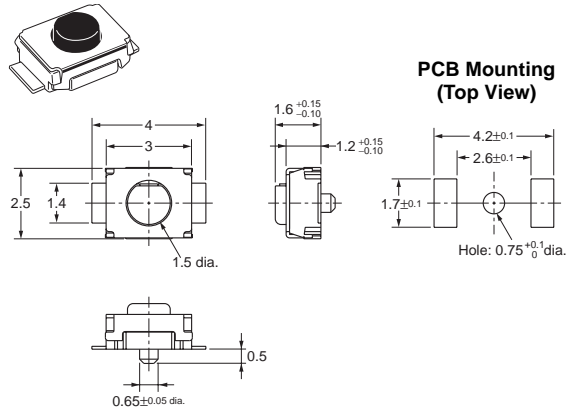

**With Ground Terminal, with Boss**

**B3U-1100P-B**

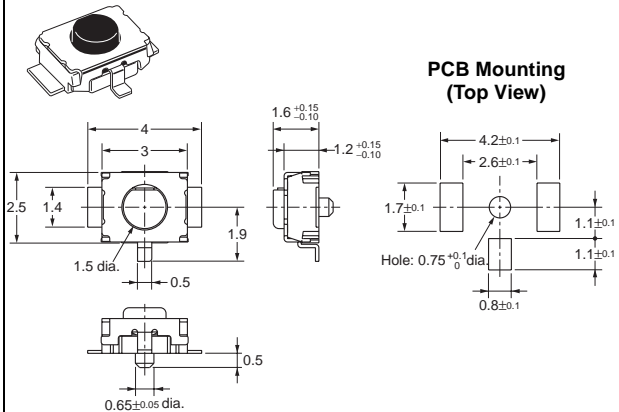

**■ Side-actuated Models**

**Note:** Unless otherwise specified, a tolerance of  $\pm 0.2$  mm applies to all dimensions.

**Without Ground Terminal, without Boss**

**B3U-3000P**

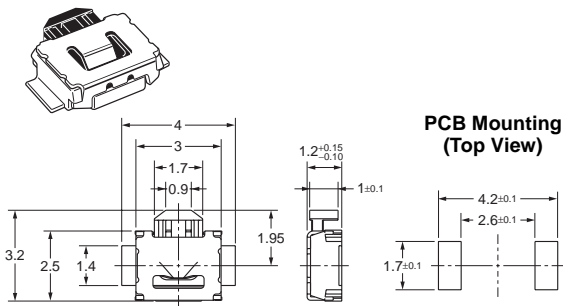

**With Ground Terminal, without Boss**

**B3U-3100P**

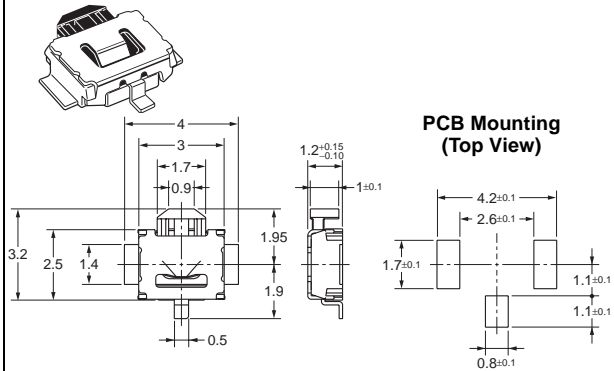

**Without Ground Terminal, with Boss**

**B3U-3000P-B**

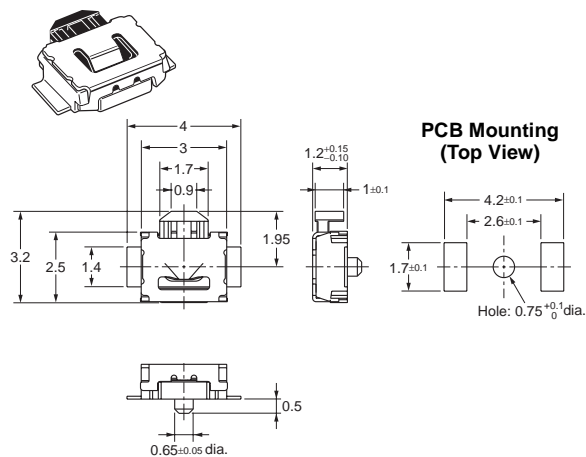

**With Ground Terminal, with Boss**

**B3U-3100P-B**

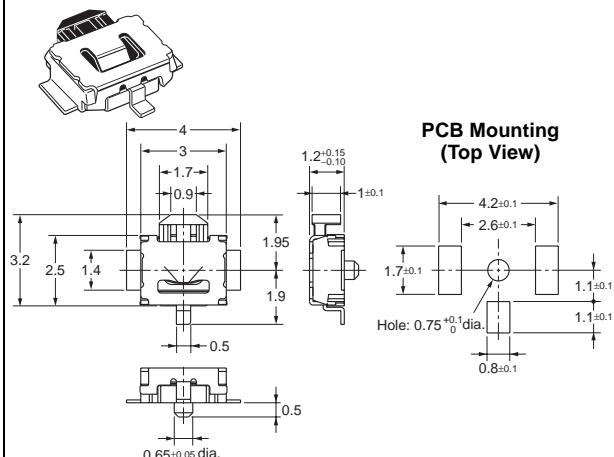

# Precautions

**Note:** Refer to *Safety Precautions* in the *Tactile Switches* (Cat. No. X037) for details on general safety precautions.

## ■ Precautions for Correct Use

### Soldering

Perform reflow soldering within the ranges shown in the terminal temperature profile in the following diagram.

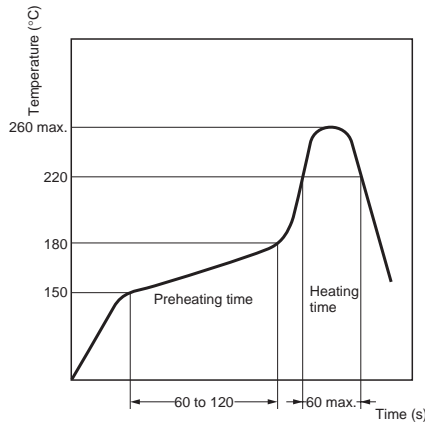

### Washing

B3U Switches cannot be washed. Doing so will cause the washing agent, together with flux or dust particles on the PCB, to enter the Switch, resulting in malfunction.

### Compliance with RoHS Directive

The "RoHS Compliant" designation indicates that the product does not contain the following six hazardous substances covered by the RoHS Directive.

Reference: The following standards are used to determine compliance for the six substances.

Lead:	1,000 ppm max.
Mercury:	1,000 ppm max.
Cadmium:	100 ppm max.
Hexavalent chromium:	1,000 ppm max.
PBB:	1,000 ppm max.
PBDE:	1,000 ppm max.

### Storage and Operating Environment

Do not store the product under the following conditions to prevent discoloration and other deterioration of the terminals.

1. Locations subject to high temperatures or humidity
2. Locations containing corrosive gases
3. Locations subject to direct sunlight

The Switch is not provided with a watertight or drip-proof construction. Do not install or operate the product in locations subject to water spray or splashes.

### Packaging Specifications

The specifications for B3U Switches packaged on embossed tape are as follows:

#### B3U-1000 Series

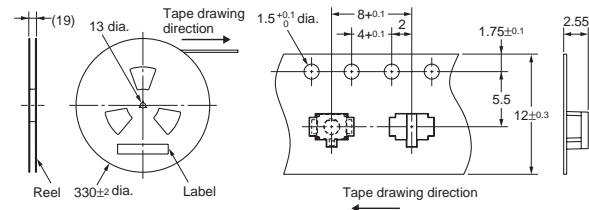

#### B3U-3000 Series

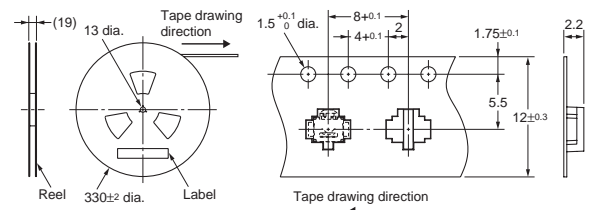

<b>Standards</b>	Conforms to JEITA.
<b>Package</b>	3,500 Switches (B3U-1000 Series) 4,000 Switches (B3U-3000 Series)
<b>Heat resistance</b>	50°C for 24 hours (without deformation)

### Operation

Do not repeatedly operate the Switch with excessive force. Applying excessive pressure or applying additional force after the plunger has stopped may deform the disc spring of the Switch, resulting in malfunction.

Be sure to set up the Switch so that the plunger will be pressed straight in. The life of the Switch may be reduced if the plunger is pressed off-center or from an angle. Do not apply pressure from above or below the plunger. Doing so may deform or damage parts or cause faulty operation.

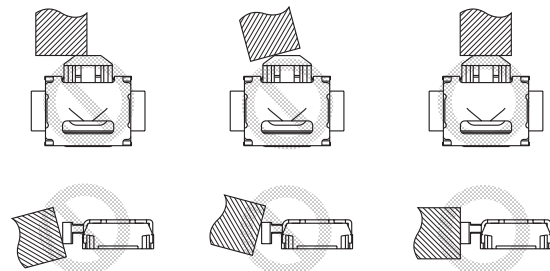

Do not operate the plunger from the side. Doing so may deform or damage the Switch.

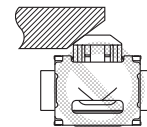

**ALL DIMENSIONS SHOWN ARE IN MILLIMETERS.**

To convert millimeters into inches, multiply by 0.03937. To convert grams into ounces, multiply by 0.03527.

Cat. No. A162-E1-03 **In the interest of product improvement, specifications are subject to change without notice.**

## **OMRON Corporation**

**Electronic Components Company**

### **Switch Division**

#### **Manual Switch Department**

Shiokoji Horikawa, Shimogyo-ku,  
Kyoto, 600-8530 Japan

Tel: (81)75-344-7096/Fax: (81)75-344-7188

Printed in Japan  
1106-3M (1006) (C)