

Product manual

Vandal resistant switch MCS 19

CONTENT

1. DESCRIPTION

[1.1 Zinc diecasting](#)

[1.2 Stainless steel](#)

[1.3 Varnished](#)

2. DATA AND DIMENSIONAL DRAWINGS

[2.1 Technical data](#)

[2.2 Component dimensions non-illuminated](#)

[2.3 Component dimensions illuminated](#)

[2.4 Drilling diagram](#)

[2.5 Circuit diagram](#)

3. ORDER NUMBERS

[3.1 Zinc diecasting - version](#)

[3.2 Stainless steel - version](#)

[3.3 Varnished version without lettering and illumination](#)

[3.4 Varnished version with lettering](#)

[3.5 Varnished version with lettering and illumination](#)

[3.6 Lettering](#)

4. PACKAGING

5. QUALIFICATION TESTS

[5.1 IP protection class](#)

[5.2 IK protection class](#)

[5.3 Salt spray test](#)

6. APPROVALS

Änderungen, die dem technischen Fortschritt dienen, bleiben vorbehalten							
Seite	Erstelldatum:	Ersteller:	Änderungsdatum:	Geändert von:	Änderungs-Nr.	Datenblatt Nr.	Index
1 of 14	13.06.06	Stiller	13.06.06		9242	105.9515	-

Print date: 20.06.2006 14:01

1 Description

1.1 Zinc diecasting

Vandal resistant switch for front panel mounting as well as for complete housings.

The front design is metal made and the mounting style of the front is with 1 mm nearly even. Also laser lettering with standard or customer specific legends is available. Additionally, a point illumination integrated in the actuator is possible. This is also possible for the stainless steel version as well as for the varnished version.

The fixing of the switch is realized with a nut M19x0.75 width across flats 22. For anti-rotation mounting a D-area has to be integrated to the mounting hole. For tight mounting please use attached sealing ring.

The switches are lined up with a spacing of 25 mm. Two contact pins with a spacing of 7.62 mm are used as terminals. The terminals are also available with pins with soldering aid or clip for pins.

The zinc diecasting version is ideal for indoor applications. For outdoor applications we recommend the stainless steel version.

1.2 Stainless steel

At this version the actuator and the housing consist of high-quality stainless steel. By using this robust weatherproof material, this version is ideal for rough environment and outdoor applications.

1.3 Varnished

With another version of the MCS19 Metallic, colour adjustments for customer housings are also possible.

Alternatively, the actuator or the switch housing can be varnished according to the provided colour specifications.

The signal colours red, green and yellow are available as standard.

After the laser lettering, the varnished actuators are sealed by transparent lacquer.

All versions are supplied with nut and sealing ring, part number 0098.9219.

The clip for terminal pins can also be ordered separately, part number 0701.9233.

Änderungen, die dem technischen Fortschritt dienen, bleiben vorbehalten							
Seite	Erstelldatum:	Ersteller:	Änderungsdatum:	Geändert von:	Änderungs-Nr.	Datenblatt Nr.	Index
2 of 14	13.06.06	Stiller	13.06.06		9242	105.9515	-

2 Data and dimensional drawings

2.1 Technical data

Electrical Data		Contact Material Gold	Contact Material Silver
Switching Voltage max.	(VDC)	24	48
Switching Voltage min.	(VDC)	50 mV	4
Switching Current max.	(mA)	80	125
Rated Breaking Capacity	(W)	0.36	1.2
Lifetime (at Rated Breaking capacity)	(mill.)	1	1
Initial Contact Resistance. new	(mΩ)	≤ 50	≤ 50
Initial Contact Resistance (after. 1 mill.)	(mΩ)	≤ 150	≤ 150
Insulation Resistance	(kΩ)	> 100.000	> 100.000
Duration of Bounce typ.	(ms)	< 5	< 5

Mechanical Data		
Actuating Force (min.)	(N)	3.7
Actuating Travel	(mm)	0.4
Lifetime (mechanical)	(mill.)	1
Starting Torque		
with Sealing Ring	(Nm)	0.4
without Sealing Ring	(Nm)	1.5

Climatical Data		
Operating Temperature	(°C)	-20 to +60
Storage Temperature	(°C)	-20 to +60

Änderungen, die dem technischen Fortschritt dienen, bleiben vorbehalten							
Seite	Erstelldatum:	Ersteller:	Änderungsdatum:	Geändert von:	Änderungs-Nr.	Datenblatt Nr.	Index
3 of 14	13.06.06	Stiller	13.06.06		9242	105.9515	-

<u>Point Illumination</u>	Attention: Switches without built-in resistance		
	Forward Current max. (mA)	Forward Voltage at IF=10mA	Forward Voltage at IF=20mA
Characteristics red LED	40	2 VDC	
Characteristics green LED	40	2 VDC	
Characteristics yellow LED	40	2 VDC	
Characteristics blue LED	20	3.2 VDC	
Characteristics red/green LED	25		2.0 / 2.2 VDC

<u>Soldering Data</u>	
Solderability IEC 68-2-20 Test Ta Method 1	235°C / 2s
Resistance to Soldering Heat IEC 68-2-20 Test Tb Method 1A	260°C / 5s

<u>Materials</u>	
Component	Material
Socket	PA
Housing	Stainless steel 1.4305
	Zinc diecasting nickel plated
Actuator unlettered	Zinc diecasting nickel plated
Actuator lettered	Stainless steel 1.4305
Snap Dome	X 12 CrNi 177 gold plated
Contacts	CuZn37 2,5µm Ag

Änderungen, die dem technischen Fortschritt dienen, bleiben vorbehalten							
Seite	Erstelldatum:	Ersteller:	Änderungsdatum:	Geändert von:	Änderungs-Nr.	Datenblatt Nr.	Index
4 of 14	13.06.06	Stiller	13.06.06		9242	105.9515	-

2.2 Component dimensions non-illuminated

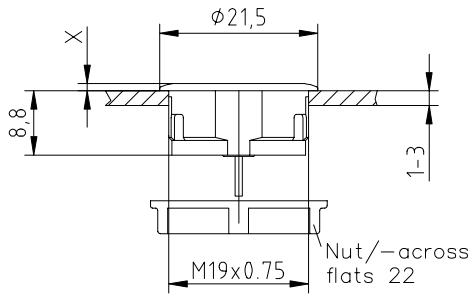

	zinc die casting	stainless steel
without sealing ring	X = 1mm	X = 1mm
with sealing ring	X = 2mm	X = 1,7mm

Models

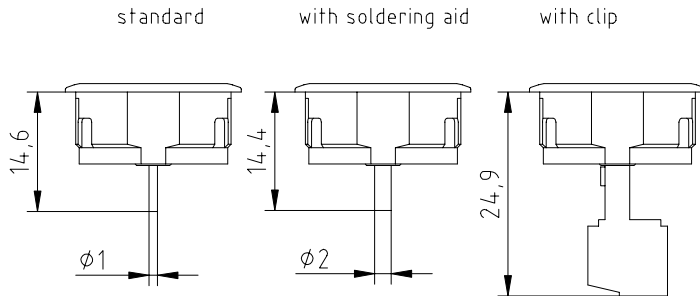

Lettering position

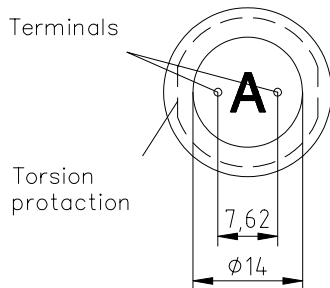

Änderungen, die dem technischen Fortschritt dienen, bleiben vorbehalten							
Seite	Erstelldatum:	Ersteller:	Änderungsdatum:	Geändert von:	Änderungs-Nr.	Datenblatt Nr.	Index
5 of 14	13.06.06	Stiller	13.06.06		9242	105.9515	-

2.3 Component dimensions illuminated

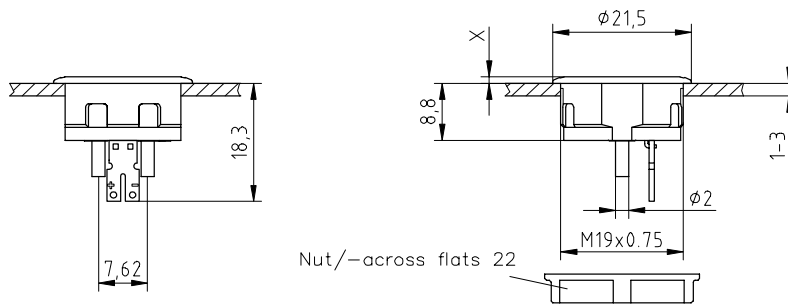

Lettering position

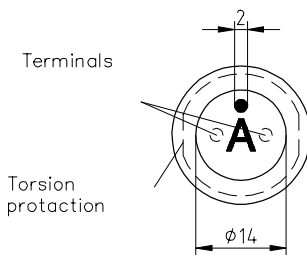

	zinc die casting	stainless steel
without sealing ring	X = 1mm	X = 1mm
with sealing ring	X = 2mm	X = 1,7mm

Änderungen, die dem technischen Fortschritt dienen, bleiben vorbehalten							
Seite	Erstelldatum:	Ersteller:	Änderungsdatum:	Geändert von:	Änderungs-Nr.	Datenblatt Nr.	Index
6 of 14	13.06.06	Stiller	13.06.06		9242	105.9515	-

Print date: 20.06.2006 14:01

2.4 Drilling diagram

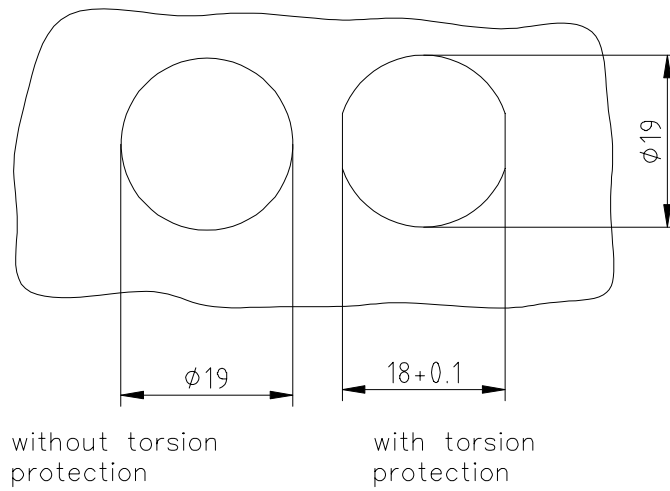

2.5 Circuit diagram

Circuit diagram

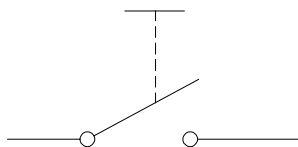

Bi-color-LED

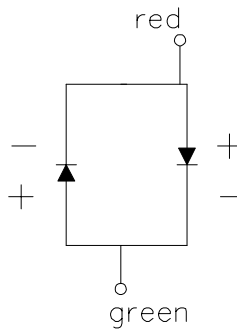

Änderungen, die dem technischen Fortschritt dienen, bleiben vorbehalten							
Seite	Erstelldatum:	Ersteller:	Änderungsdatum:	Geändert von:	Änderungs-Nr.	Datenblatt Nr.	Index
7 of 14	13.06.06	Stiller	13.06.06		9242	105.9515	-

3 Order Numbers

3.1 Zinc diecasting - version

Part number	Terminal	Contacts	Illumination
1241.2800	standard	silver	-----
1241.2801	with soldering aid	silver	-----
1241.2802	with clip	silver	-----
1241.2805.XXX	standard	silver	-----
1241.2806.XXX	with soldering aid	silver	-----
1241.2807.XXX	with clip	silver	-----
1241.2810	standard	gold	-----
1241.2812	with clip	gold	-----
1241.2815.XXX	standard	gold	-----
1241.2817.XXX	with clip	gold	-----
1241.2855.XXX	with soldering aid	silver	red
1241.2856.XXX	with soldering aid	silver	green
1241.2857.XXX	with soldering aid	silver	yellow
1241.2858.XXX	with soldering aid	silver	red-green
1241.2859.XXX	with soldering aid	silver	blue

----- Legend index (see page 11)

3.2 Stainless steel - version

Part number	Terminal	Contacts	Illumination
1241.2820.XXX	standard	silver	-----
1241.2821.XXX	with soldering aid	silver	-----
1241.2822.XXX	with clip	silver	-----
1241.2825.XXX	standard	gold	-----
1241.2827.XXX	with clip	gold	-----
1241.2830.XXX	with soldering aid	silver	red
1241.2831.XXX	with soldering aid	silver	green
1241.2832.XXX	with soldering aid	silver	yellow
1241.2833.XXX	with soldering aid	silver	red-green
1241.2834.XXX*	with soldering aid	silver	blue

----- Legend index (see page 11)

with “ * “ marked part number on request

Änderungen, die dem technischen Fortschritt dienen, bleiben vorbehalten							
Seite	Erstelldatum:	Ersteller:	Änderungsdatum:	Geändert von:	Änderungs-Nr.	Datenblatt Nr.	Index
8 of 14	13.06.06	Stiller	13.06.06		9242	105.9515	-

3.6 Lettering

The last three digits in the order no. define the lettering.

000	No lettering
001-072	Standard lettering
101-	Customized lettering

Example for ordering an lettering

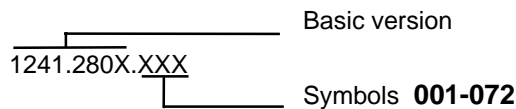

Ordering indices for lettering

001= A	016= P	031= 4	046= ⇕	061= EIN
002= B	017= Q	032= 5	047= →	062= AUS
003= C	018= R	033= 6	048= ←	063= AUF
004= D	019= S	034= 7	049= ↓	064= AB
005= E	020= T	035= 8	050= ↑	065= ON
006= F	021= U	036= 9	051= %	066= OFF
007= G	022= V	037= +	052= √	067= UP
008= H	023= W	038= –	053= CTRL	068= DOWN
009= I	024= X	039= .	054= RETURN	069= HIGH
010= J	025= Y	040= ×	055= SHIFT	070= LOW
011= K	026= Z	041= ÷	056= LOCK	071= ON/OFF
012= L	027= 0	042= *	057= STOP	072= START
013= M	028= 1	043= =	058= ENTER	
014= N	029= 2	044= #	059= BACK	
015= O	030= 3	045= ↔	060= LINE	

Font size

Single characters: height 5 mm, font size: Helvetica normal DIN1451 E1
Legends, max. 6 characters: height 2,5 mm, font size: Helvetica condensed DIN1451-3E
Symbols (Indice 037-052): capitals height 5 mm, font size: True Type, Symbol

Änderungen, die dem technischen Fortschritt dienen, bleiben vorbehalten							
Seite	Erstelldatum:	Ersteller:	Änderungsdatum:	Geändert von:	Änderungs-Nr.	Datenblatt Nr.	Index
11 of 14	13.06.06	Stiller	13.06.06		9242	105.9515	-

4 Packaging

MSC 19 Switch

MSC 19	standard and with soldering aid	20 pieces per box with inlay
MCS 19	with clip	10 pieces per box with inlay

The nuts and sealing ring are packed separately and are enclosed in the box.



Änderungen, die dem technischen Fortschritt dienen, bleiben vorbehalten							
Seite	Erstelldatum:	Ersteller:	Änderungsdatum:	Geändert von:	Änderungs-Nr.	Datenblatt Nr.	Index
12 of 14	13.06.06	Stiller	13.06.06		9242	105.9515	-

5 Qualification Tests

5.1 IP protection class

IP degree of protection IEC/DIN/EN/ 60529	from the front	IP 40
	Switching unit	IP 67

5.2 IK protection class

Test carried out centrally.

IK protection class DIN EN 50102	IK 05
-------------------------------------	-------

5.3 Salt spray test

Stainless steel version

Salt spray test according to DIN 50021- SS
24h, 48h and 96h residence time

The surface of the stainless steel material is covered with a molecular-passiv layer. Only under very unfavourable conditions, it is possible that iron and rust molecules as well as base metals penetrate the passive layer as foreign substances (pollutions) and initiate the rust process.

The actuation of the switch was not affected. After the residence time the tested samples were cleaned under running water and all rust spots could be removed.

Zinc diecasting nickel-plated

Salt spray test according to DIN 50021- SS
24h residence time

The surface of the zinc diecasting version shows no signs off corrosion.

Änderungen, die dem technischen Fortschritt dienen, bleiben vorbehalten							
Seite	Erstelldatum:	Ersteller:	Änderungsdatum:	Geändert von:	Änderungs-Nr.	Datenblatt Nr.	Index
13 of 14	13.06.06	Stiller	13.06.06		9242	105.9515	-

6 Approvals



EG - Konformitätserklärung

Die

Schurter GmbH, Elsaesserstrasse 3, D-79346 Endingen

erklärt, dass das folgend bezeichnete Produkt

**Schurter
MCS 19**

(Teilenummer 1241.2800, 1241.2806
1241.2820, 1241.2855)

den Anforderungen entspricht, die in der Richtlinie des Rates zur Angleichung der Rechtsvorschriften der Mitgliedsstaaten über die elektromagnetische Verträglichkeit (89/336/EWG) festgelegt sind.

Zur Beurteilung der elektromagnetischen Verträglichkeit wurden folgende Normen herangezogen:

- Bahnanwendungen
nach DIN EN 50155
und DIN EN 50125:

Die Prüfungen wurden durch die externen, unabhängigen Prüflabore „Botronic and EMV-Schuhwerk, Tuningen“ durchgeführt.

Diese Erklärung wird verantwortlich für den Hersteller abgegeben durch
Bruno Ochs, Geschäftsführer

Endingen, den 20.09.2004
(Ort, Datum / place, date)



EU Declaration of Conformity

The

Schurter GmbH, Elsaesserstrasse 3, D-79346 Endingen

declares, that the product described below

**Schurter
MCS 19**

(part number 1241.2800, 1241.2806
1241.2820, 1241.2855)

is in compliance with the European Council Directive of 3.5.89 on the approximation of the laws of the Member States relating to electromagnetic compatibility of appliance (89/336/EWG).

The following requirements / standards / specifications constitute part of this declaration:

- Application for railway
according to DIN EN 50155
and DIN EN 50125:

The tests have been performed by the external, independent laboratories „Botronic and EMV-Schuhwerk, Tuningen“

On behalf of the manufacturer:
Bruno Ochs, Managing Director

(Rechtsgültige Unterschrift / authorized signature)

Änderungen, die dem technischen Fortschritt dienen, bleiben vorbehalten							
Seite	Erstelldatum:	Ersteller:	Änderungsdatum:	Geändert von:	Änderungs-Nr.	Datenblatt Nr.	Index
14 of 14	13.06.06	Stiller	13.06.06		9242	105.9515	-