







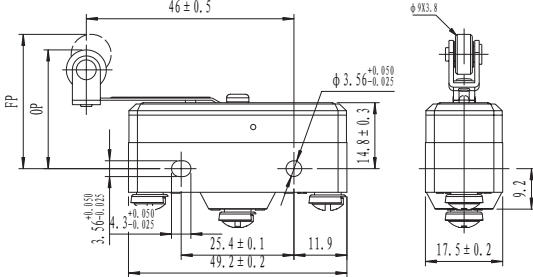

SPECIFICATION

Operating Frequency	mechanically 240 ops/min electrically 20 ops/min
Service Life	mechanically 1 X 10 ⁶ (ops.) electrically 5 X 10 ⁵ (ops.)
Electrical Rating	15A@ 250VAC
Rated Voltage	600VAC
Ambient Humidity	-20~+80°C (-4~176°F)
Dielectric Strength	2500VAC 50/60Hz (For 1 min)
Dielectric Strength	IP63
Definition Of Characteristics	
OF Operation Force	PT Pre-Travel
RF Releasing Force	MD Movement Differential
OT Over-Travel	OP Operation Position
TT Total-Travel	PO Travel to Positive Opening

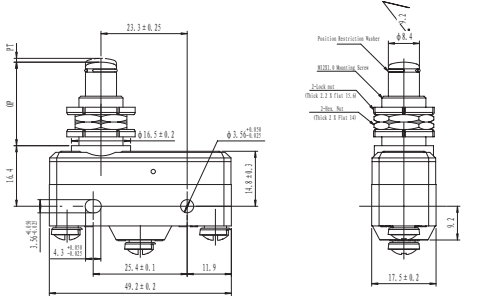

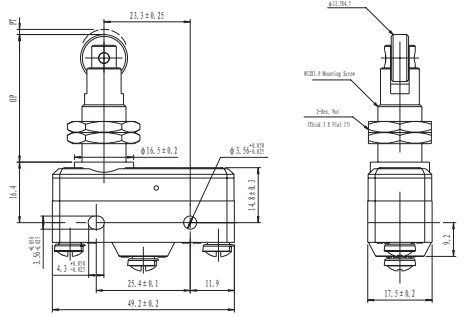
DIMENSIONS

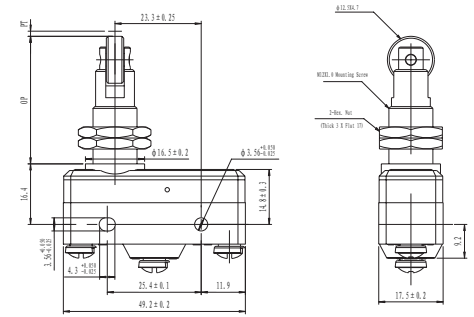
<p>BZC-2R-A2</p>		<p>Operating Characteristics</p> <ul style="list-style-type: none"> • OF_{max} 3.61N • RF_{min} 1.11N • PT_{max} 0.4mm • OT_{min} 0.13mm • MD_{max} 0.05mm • OP 15.9±0.4mm
<p>BZC-2RD-A2</p>		<p>Operating Characteristics</p> <ul style="list-style-type: none"> • OF_{max} 3.61N • RF_{min} 1.11N • PT_{max} 0.4mm • OT_{min} 1.52mm • MD_{max} 0.05mm • OP 21.5±0.5mm
<p>BZC-2RL-A2</p>		<p>Operating Characteristics</p> <ul style="list-style-type: none"> • OF_{max} 1.39N • RF_{min} 0.14N • OT_{min} 1.52mm • MD_{max} 1.27mm • FP_{max} 20.6mm • OP 17.4±0.8mm

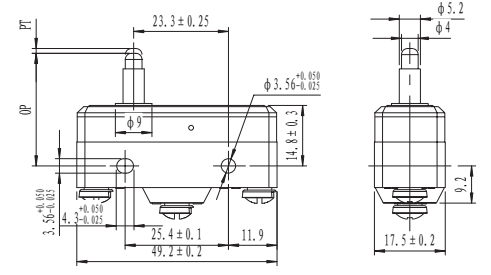
<p>BZC-2RL2-A2</p> 	 <p>Operating Characteristics</p> <ul style="list-style-type: none"> • OF_{max} 1.39N • RF_{min} 0.14N • OT_{min} 1.6mm • MD_{max} 1.27mm • FP 31.8mm • OP 28.6 ± 0.8mm
<p>BZC-2RQ1-A2</p> 	 <p>Operating Characteristics</p> <ul style="list-style-type: none"> • OF_{max} 3.61N • RF_{min} 1.11N • PT_{max} 0.4mm • OT_{min} 5.56mm • MD_{max} 0.05mm • OP 21.8 ± 0.8mm
<p>BZC-2RQ18-A2</p> 	 <p>Operating Characteristics</p> <ul style="list-style-type: none"> • OF_{max} 3.61N • RF_{min} 1.11N • PT_{max} 0.4mm • OT_{min} 3.6mm • MD_{max} 0.05mm • OP 33.3 ± 1.1mm
<p>BZC-2RQ181-A2</p> 	 <p>Operating Characteristics</p> <ul style="list-style-type: none"> • OF_{max} 3.61N • RF_{min} 1.11N • PT_{max} 0.4mm • OT_{min} 3.6mm • MD_{max} 0.05mm • OP 33.3 ± 1.1mm
<p>BZC-2RS-A2</p> 	 <p>Operating Characteristics</p> <ul style="list-style-type: none"> • OF_{max} 3.61N • RF_{min} 1.11N • PT_{max} 0.4mm • OT_{min} 1.52mm • MD_{max} 0.05mm • OP 28.2 ± 0.6mm

BZC-2RW80-A2

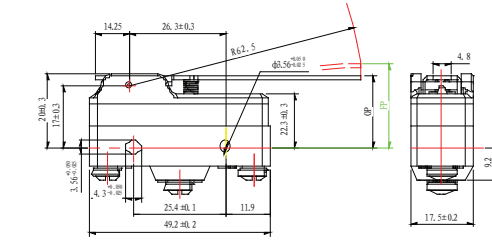

Operating Characteristics

- OF_{max} 0.69N
- RF_{min} 0.14N
- OT_{min} 5.6mm
- MD_{max} 2mm
- FP_{max} 28.2mm
- OP 19.05 ± 0.8mm

BZC-2RW876T

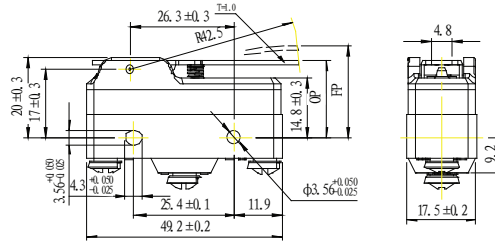

Operating Characteristics

- OF_{max} 1.03N
- RF_{min} 0.21N
- OT_{min} 3.7mm
- MD_{max} 0.85mm
- FP_{max} 24.5mm
- OP 19.05 ± 0.5mm

BZC-2RW82-A2

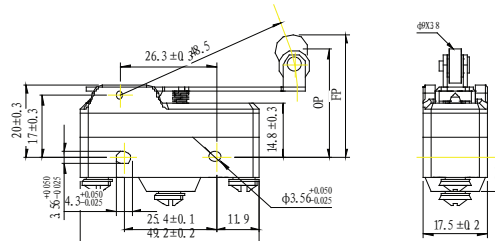

Operating Characteristics

- OF_{max} 0.98N
- RF_{min} 0.21N
- OT_{min} 4mm
- MD_{max} 1.02mm
- FP_{max} 36.5mm
- OP 30.2 ± 0.8mm

BZC-2RW822-A2

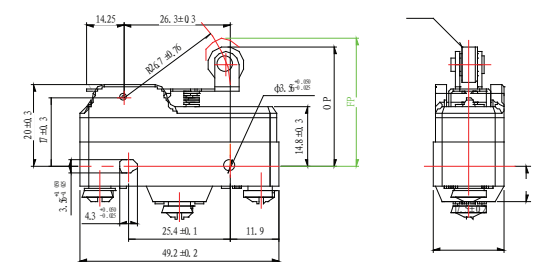

Operating Characteristics

- OF_{max} 1.67N
- RF_{min} 0.42N
- OT_{min} 2.4mm
- MD_{max} 0.8mm
- FP_{max} 32.5mm
- OP 30.2 ± 0.4mm

BZC-2RW826-A2

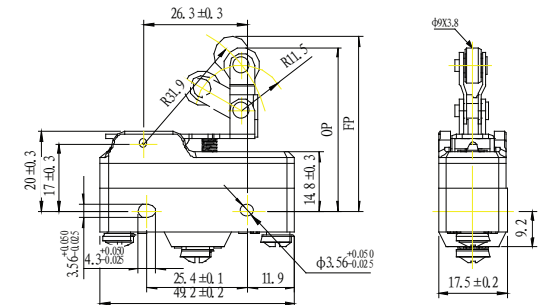

Operating Characteristics

- OF_{max} 1.67N
- RF_{min} 0.41N
- OT_{min} 2.4mm
- MD_{max} 0.8mm
- FP_{max} 43.5mm
- OP 41.3 ± 0.8mm