

Insertable Legend Keypads

4200 Series



Features:

- Adhesive backed for easy mounting.
- Allows for custom legends.
- Legends easily swapped.
- Tactile feedback on all keys.
- Rim embossed keys for finger placement.
- Splashproof, sealed switches.

4214A1

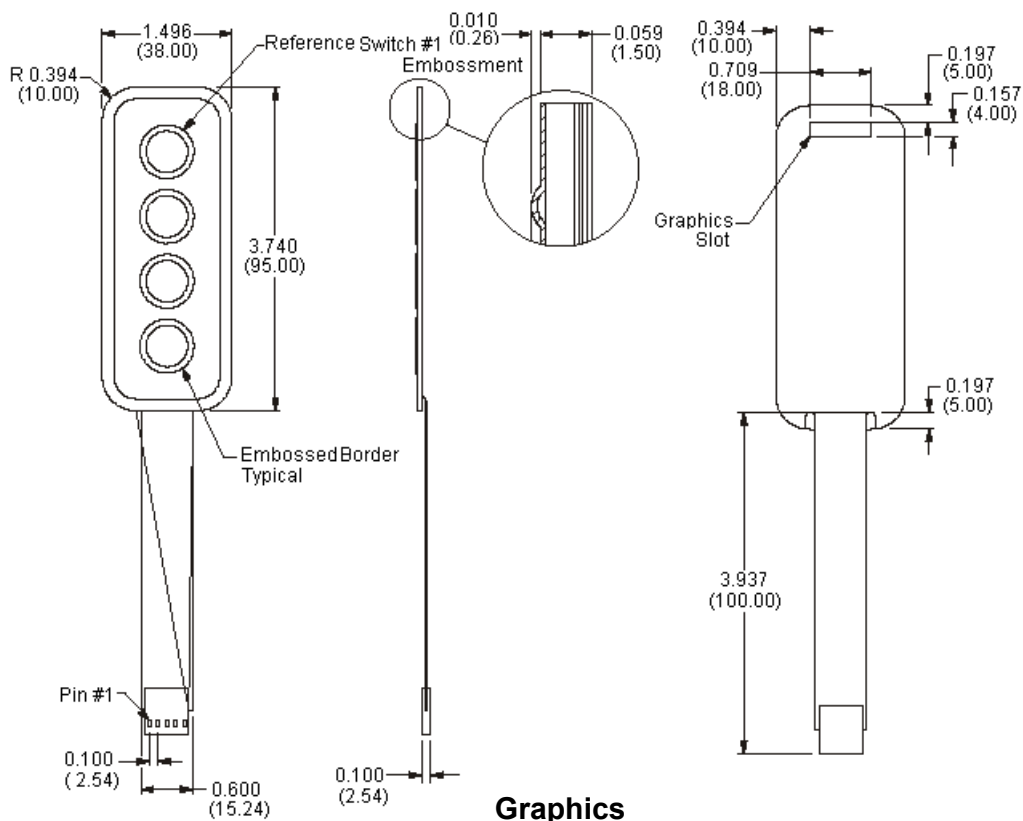
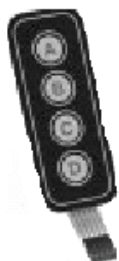

Schematic

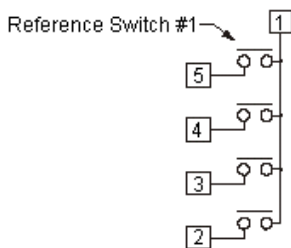

X - Y matrix output circuit configuration switch function - SPST NO momentary.

Graphics

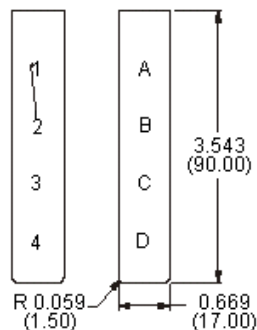

Both inserts supplied with each keypad

Dimensions : Inches (Millimetres)

<http://www.farnell.com>
<http://www.newark.com>
<http://www.cpc.co.uk>



Insertable Legend Keypads

4200 Series



4234A1

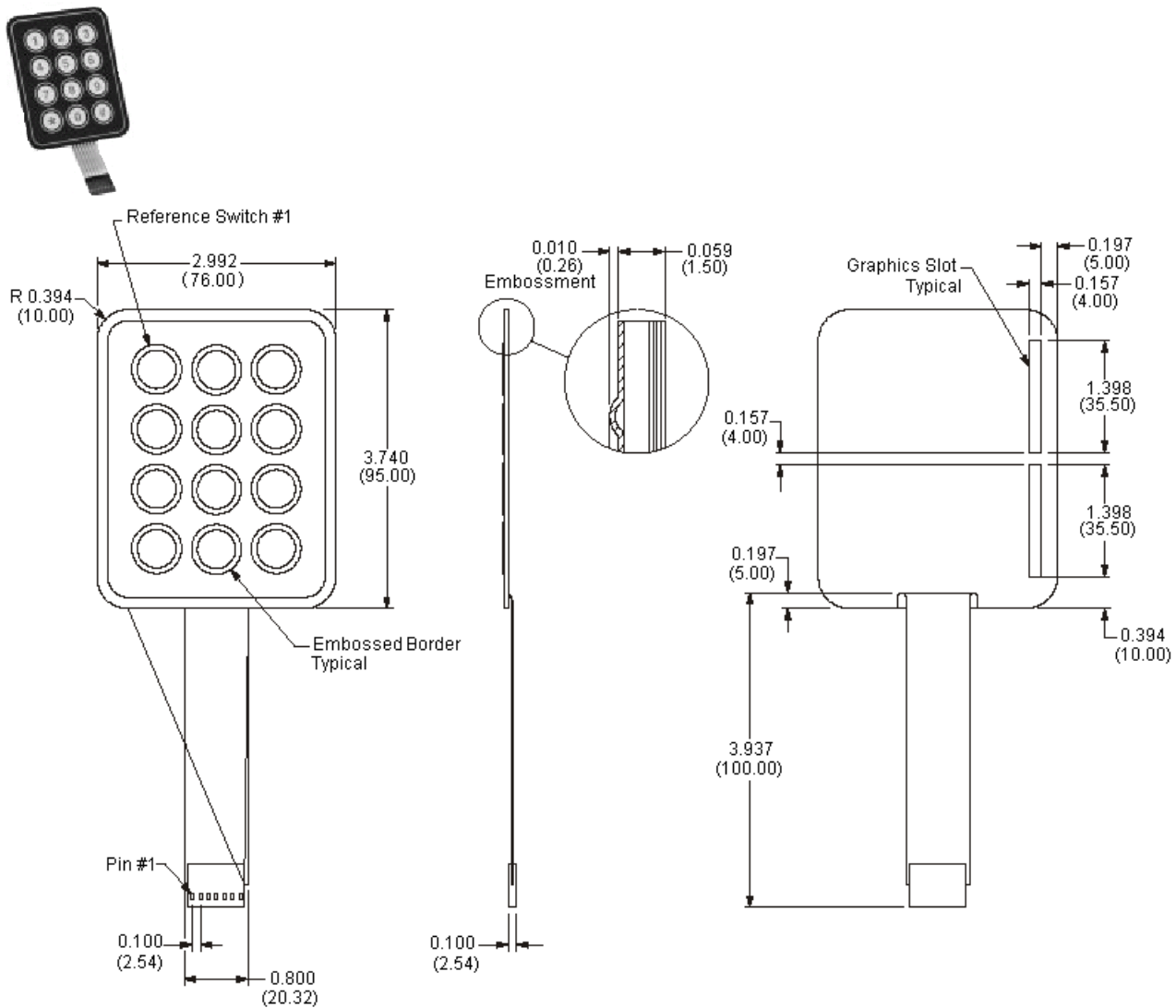

Schematic

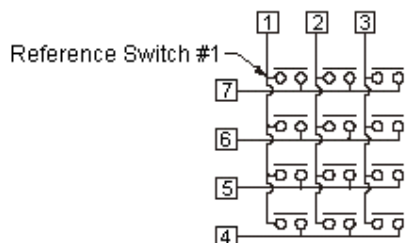

X - Y matrix output circuit configuration switch function - SPST NO momentary.

Graphics

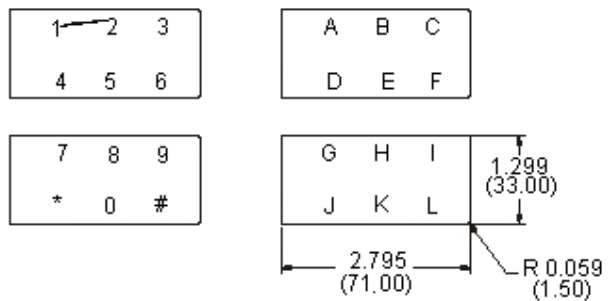

All (4) inserts supplied with each keypad

Dimensions : Inches (Millimetres)

<http://www.farnell.com>
<http://www.newark.com>
<http://www.cpc.co.uk>



Insertable Legend Keypads

4200 Series



4244A1

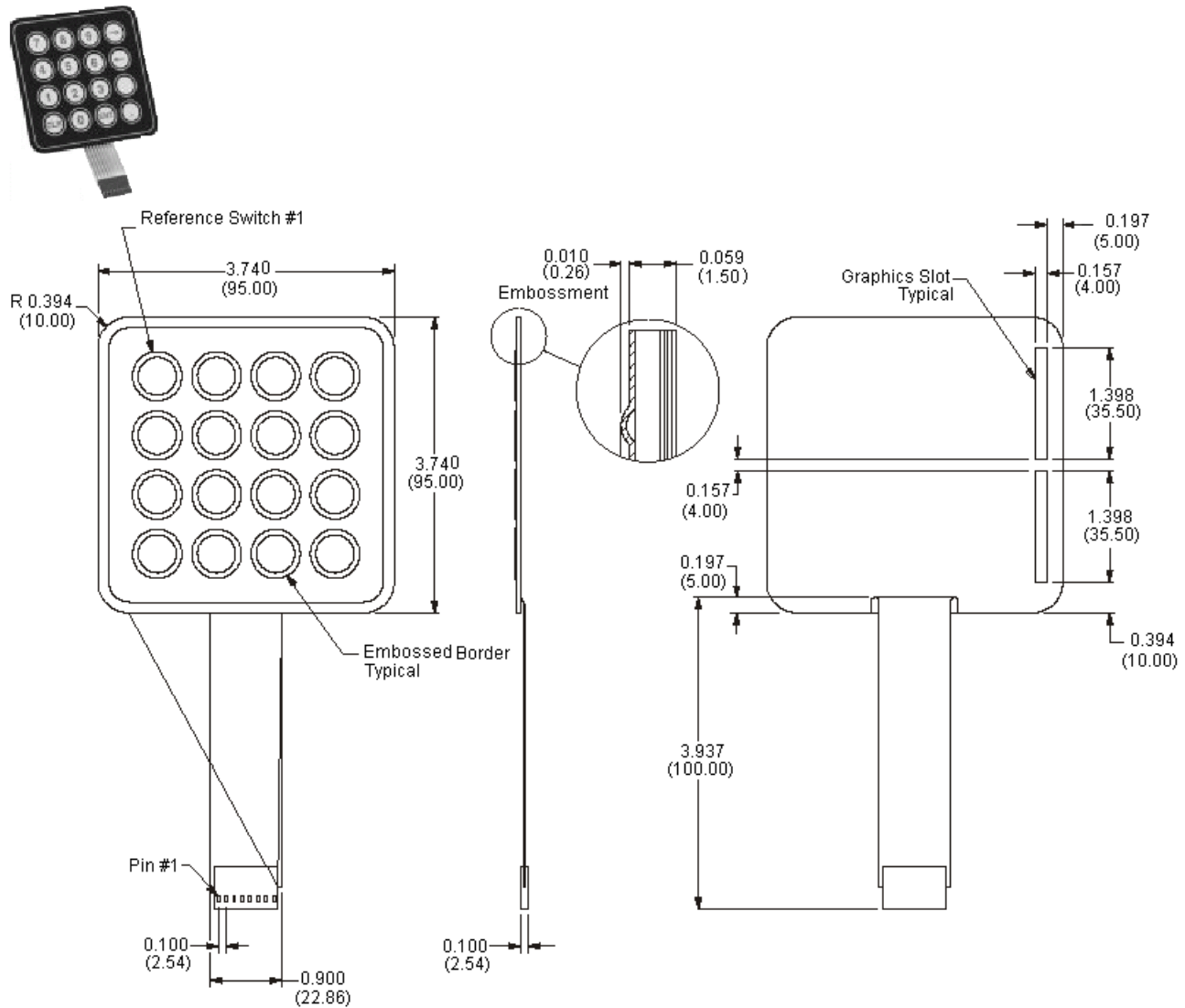

Schematic

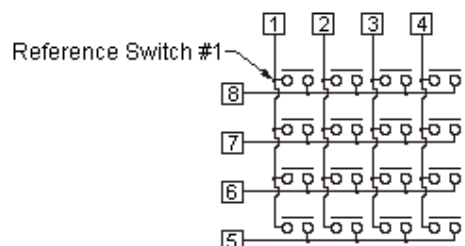

X - Y matrix output circuit configuration switch function - SPST NO momentary.

Graphics

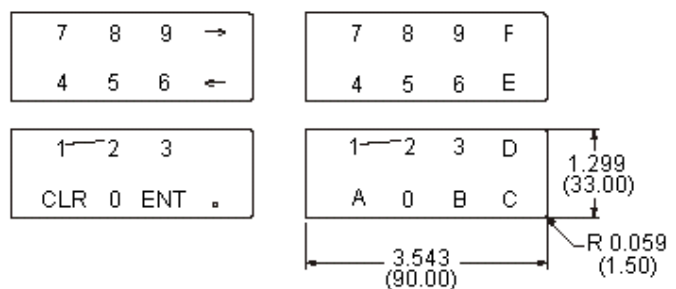

All (4) inserts supplied with each keypad

Dimensions : Inches (Millimetres)

<http://www.farnell.com>
<http://www.newark.com>
<http://www.cpc.co.uk>



Insertable Legend Keypads

4200 Series



Specifications

Switch function	: SPST, momentary, normally open.
Maximum contact rating	: 0.5VA, 100mA, 30 V dc.
Actuation force	: 300 ±50 grams.
Minimum insulation resistance	: 5MΩ.
Minimum dielectric strength	: 250V rms
Capacitance	: 10pF typical.
Contact bounce	: Below 10M seconds typical.
Travel	: 0.63 to 0.76mm (0.025 to 0.030) typical.
Storage temperature	: -40°to 60°C.
Operating temperature	: -30°to 60°C.

Materials:

Overlay	: Polyester/polycarbonate blend with uniform low gloss fine texture.
Contacts and circuits	: Silver conductive PTF traces on heat stabilized polyester film.
Connector	: Single row female connector, tin lead plating.

Specification Table

Description	Number of Keys	Detent	Connector	Part Number
Keypad, 1 x 4 Array	4	Yes	Female	4214A1
Keypad, 3 x 4 Array	12			4234A1
Keypad, 4 x 4 Array	16			4244A1

Disclaimer This data sheet and its contents (the "Information") belong to the Premier Farnell Group (the "Group") or are licensed to it. No licence is granted for the use of it other than for information purposes in connection with the products to which it relates. No licence of any intellectual property rights is granted. The Information is subject to change without notice and replaces all data sheets previously supplied. The Information supplied is believed to be accurate but the Group assumes no responsibility for its accuracy or completeness, any error in or omission from it or for any use made of it. Users of this data sheet should check for themselves the Information and the suitability of the products for their purpose and not make any assumptions based on information included or omitted. Liability for loss or damage resulting from any reliance on the Information or use of it (including liability resulting from negligence or where the Group was aware of the possibility of such loss or damage arising) is excluded. This will not operate to limit or restrict the Group's liability for death or personal injury resulting from its negligence. SPC Multicomp is the registered trademark of the Group. © Premier Farnell plc 2009.

<http://www.farnell.com>
<http://www.newark.com>
<http://www.cpc.co.uk>

