

Footswitches with two pedals

F2

Protection class IP 65



Designation	F2-U1Z/U1Z	F2-U2Z/U2Z
Part number	606.2110.013	606.2220.015
Circuit diagram		
Slow make & break/snap action	●/-	●/-
Pressure point	-	-
Latching switch	-	-
Potentiometer	-	-
Pedal interlocking	-	-
Emergency stop function	-	-
Power contactor	-	-
Voltage	max. 500 V AC	500 V AC
Permanent current	max. 10 A	10 A
In-rush current complies with standards IEC 947-5-1 AC 15/DC 13	●	●
Switching frequency	max. 50/min.	50/min.
Mechanical life – number of switching actions	10 x 10 ⁶	10 x 10 ⁶
Mechanical life – number of revolutions	-	-
Operating temperature	min./max. -30 °C/+80 °C -22 °F/+176 °F	-30 °C/+80 °C -22 °F/+176 °F
Approvals	BG, CSA, UL	BG, CSA, UL
Cable entry	1 x M 20	1 x M 20
Weight	1.70 kg/3.7 lb	1.70 kg/3.7 lb
Delivery: ex-stock/built to order	●/-	●/-

All dimensions in mm (inch)

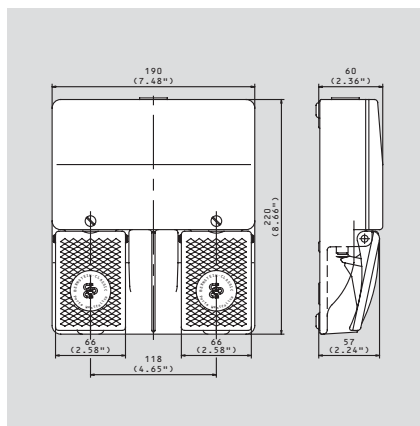

Footswitches with two pedals (guarded) F2 UN

With three pedals F3

With three pedals (guarded) F3 UN

Protection class IP 65



Designation	F2-U1Z/U1Z UN	F2-SU1Z/SU1Z UN	F2-U2Z/U2Z UN	F2-U2ZD/U2ZD UN
Part number	606.2610.014	606.2830.022	606.2720.016	606.2720.020
Circuit diagram				
Slow make & break/snap action	●/-	●/-	-/●	-/●
Pressure point	-	-	-	●
Latching switch	-	-	-	-
Potentiometer	-	-	-	-
Pedal interlocking	-	-	-	-
Emergency stop function	-	-	-	-
Power contactor	-	-	-	-
Voltage	500 V AC	500 V AC	500 V AC	500 V AC
Permanent current	10 A	10 A	10 A	10 A
In-rush current complies with standards IEC 947-5-1 AC 15/DC 13	●	●	●	●
Switching frequency	50/min.	50/min.	50/min.	50/min.
Mechanical life – number of switching actions	10 x 10 ⁶	10 x 10 ⁶	10 x 10 ⁶	10 x 10 ⁶
Mechanical life – number of revolutions	-	-	-	-
Operating temperature	-30 °C/+80 °C -22 °F/+176 °F	-30 °C/+80 °C -22 °F/+176 °F	-30 °C/+80 °C -22 °F/+176 °F	-30 °C/+80 °C -22 °F/+176 °F
Approvals	BG, CSA, UL	BG, CSA, UL	BG, CSA, UL	BG, CSA, UL
Cable entry	1 x M 20	1 x M 20	1 x M 20	1 x M 20
Weight	2.60 kg/5.7 lb	2.60 kg/5.7 lb	2.60 kg/5.7 lb	2.80 kg/6.2 lb
Delivery: ex-stock/built to order	●/-	●/-	●/-	●/-

All dimensions in mm (inch)

