

### Low-cost Rotary DIP Switches

- Series includes top-actuated, side-actuated, flat, and extended-shaft models.
- The rotor has an O-ring sealed construction that prevents the ingress of dirt and dust.
- Two different types of terminal arrangement are available for each model to allow flexibility in the circuit design.

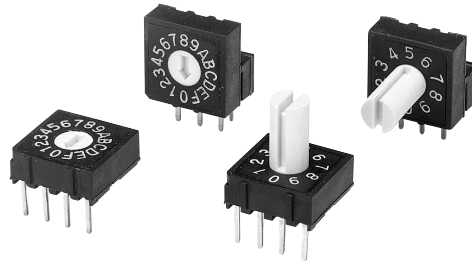

## Ordering Information

### List of Models

				Type (rotor color)	Top-actuated, flat (White)	Top-actuated, extended shaft (White)	Side-actuated, flat (White)	Side-actuated, extended shaft (White)
				Appearance				
Number of positions	Quantity per stick	Terminal arrangement	Output code					
10	48	4 × 1	Real code	A6R-101RF	A6R-101RS	A6RV-101RF	A6RV-101RS	
		3 × 3	Real code	A6R-102RF	A6R-102RS	A6RV-102RF	A6RV-102RS	
16	48	4 × 1	Real code	A6R-161RF	A6R-161RS	A6RV-161RF	A6RV-161RS	
		3 × 3	Real code	A6R-162RF	A6R-162RS	A6RV-162RF	A6RV-162RS	

**Note:** Switches are delivered in units of 48. Orders must be made in multiples of 48.

## Specifications

### Ratings/Characteristics

<b>Rating</b>	25 mA at 24 VDC
<b>Ambient operating temperature</b>	-25 to 80°C (with no icing or condensation)
<b>Ambient operating humidity</b>	35% to 95%
<b>Insulation resistance</b>	100 MΩ min. (at 250 VDC)
<b>Contact resistance</b>	200 mΩ max. (initial value)
<b>Dielectric strength</b>	250 VAC for 1 minute between terminals of the same polarity
<b>Vibration resistance</b>	Malfunction: 10 to 55 Hz, 1.5-mm double amplitude
<b>Shock resistance</b>	Malfunction: Approx. 300 m/s <sup>2</sup>
<b>Electrical life expectancy</b>	5,000 steps min.
<b>Operating torque</b>	1.96 × 10 <sup>-2</sup> N·m max.
<b>Weight</b>	4×1, top-actuated: 0.64 g 3×3, top-actuated: 0.62 g 4×1, side-actuated: 0.8 g 3×3, side-actuated: 0.83 g (Add 0.13 g for the extended-shaft version of each model.)

### Output Codes

#### 10-position Models

Code Position	Real code			
	1	2	4	8
0				
1	●			
2		●		
3	●	●		
4			●	
5	●	●	●	
6		●	●	
7	●	●	●	
8				●
9	●			●

#### 16-position Models

Code Position	Real code			
	1	2	4	8
0				
1	●			
2		●		
3	●	●		
4			●	
5	●	●	●	
6		●	●	
7	●	●	●	
8				●
9	●			●
A		●		●
B	●	●		●
C			●	●
D	●		●	●
E		●	●	●
F	●	●	●	●

**Note:** "●" indicates that the internal switch is ON.

## Dimensions

- Note:** 1. All units are in millimeters unless otherwise indicated.  
2. A tolerance of  $\pm 0.4$  mm applies to the above dimensions unless otherwise specified.

### Top-actuated Flat Models with 4×1 Terminal Arrangement

A6R-101RF  
A6R-161RF

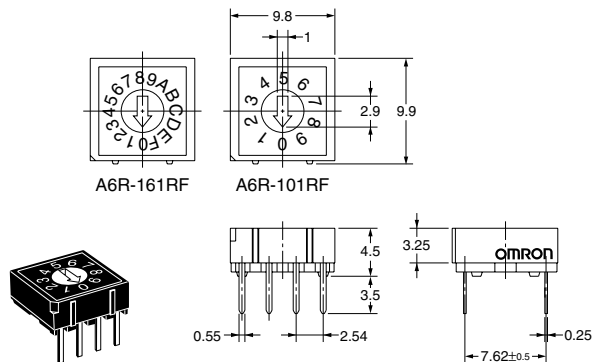

### Top-actuated Extended-shaft Models with 4×1 Terminal Arrangement

A6R-101RS  
A6R-161RS

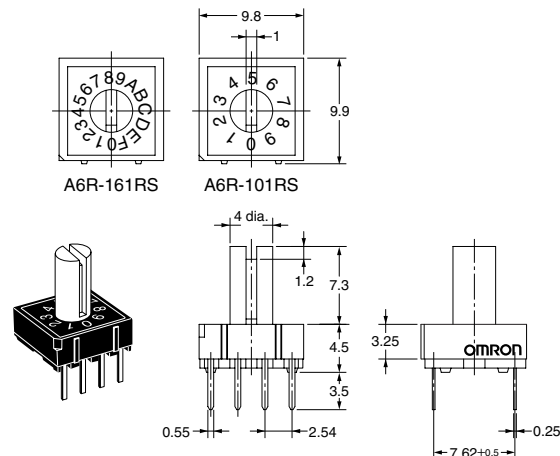

### Top-actuated Flat Models with 3×3 Terminal Arrangement

A6R-102RF  
A6R-162RF

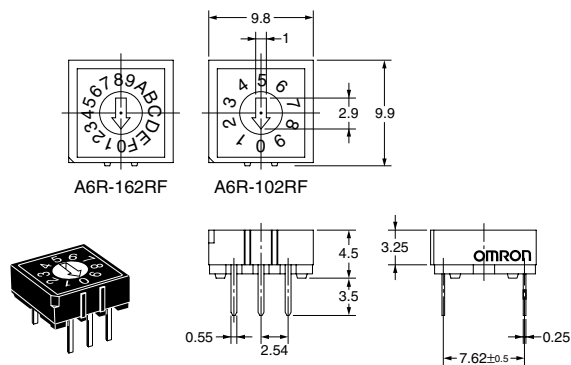

### Top-actuated Extended-shaft Models with 3×3 Terminal Arrangement

A6R-102RS  
A6R-162RS

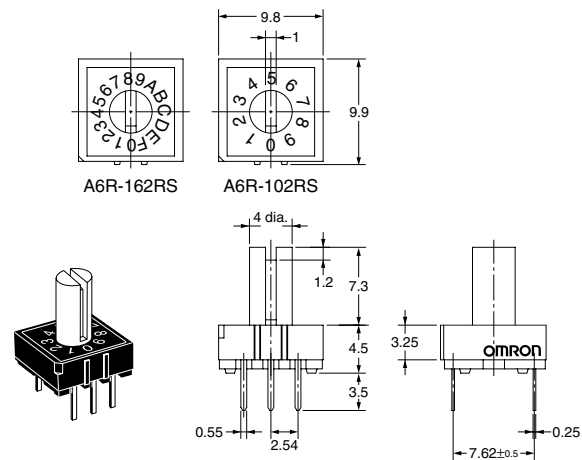

**Side-actuated Flat Models with 4×1 Terminal Arrangement**

A6RV-101RF  
A6RV-161RF

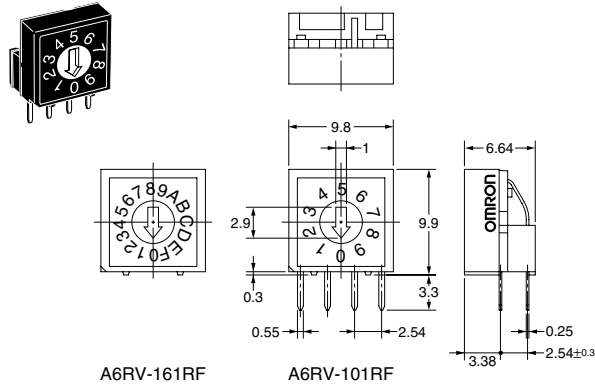

**Side-actuated Extended-shaft Models with 4×1 Terminal Arrangement**

A6RV-101RS  
A6RV-161RS

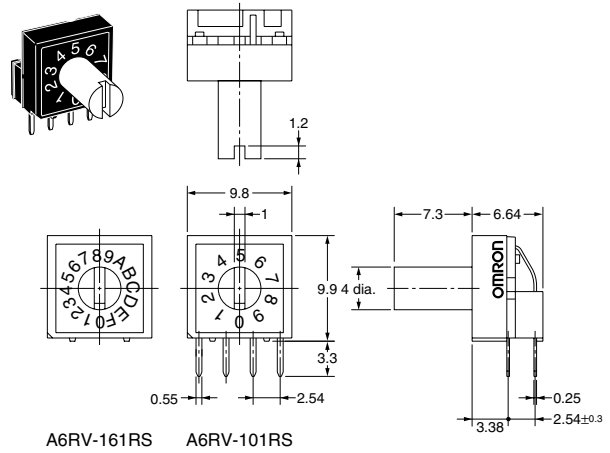

**Side-actuated Flat Models with 3×3 Terminal Arrangement**

A6RV-102RF  
A6RV-162RF

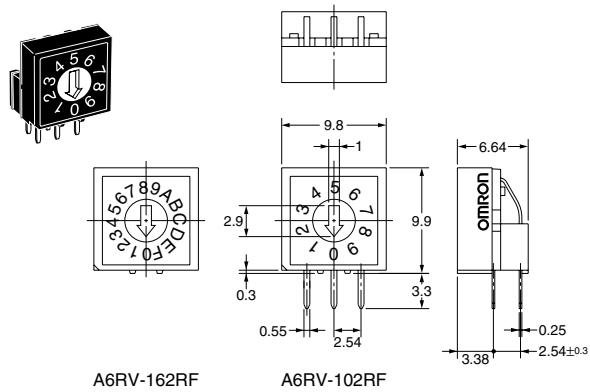

**Side-actuated Extended-shaft Models with 3×3 Terminal Arrangement**

A6RV-102RS  
A6RV-162RS

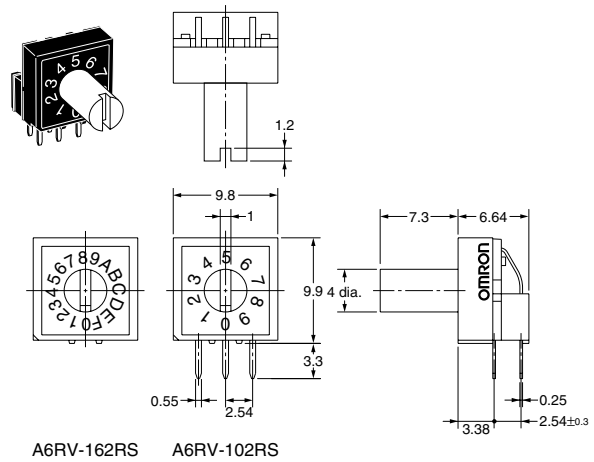

**PCB Cutout Dimensions**

**Top-actuated Models**

4×1 Terminal Arrangement

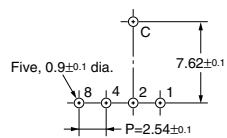

3×3 Terminal Arrangement

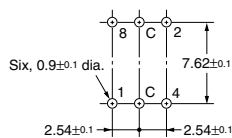

**Side-actuated Models**

4×1 Terminal Arrangement

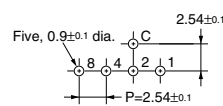

3×3 Terminal Arrangement

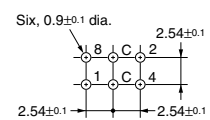

## Precautions

---

Be sure to refer to General Precautions on pages 4 to 6 for details on proper use.

**ALL DIMENSIONS SHOWN ARE IN MILLIMETERS.**

To convert millimeters into inches, multiply by 0.03937. To convert grams into ounces, multiply by 0.03527.

Cat. No. A512-E1-02